

AN ABSTRACT FROM
PRELIMINARY REPORT
ON THE
STATE OF IOWA LEGISLATIVE
CHAMBER AUDIO SYSTEM
COVERING
SYSTEM UPGRADE AND
BUDGETARY COST ESTIMATES

JUNE 7, 1976

PREPARED BY:



sigma associates inc.

COMMUNICATION SYSTEM SPECIALISTS
BOX 2044 • 330 1st ST. S.E. • CEDAR RAPIDS, IA. 52406
TELEPHONE 319 366-1821

TABLE OF CONTENTS

1.0	HOUSE OF REPRESENTATIVES	
1.1	PRESENT SYSTEM	
	- Schematic	1
	- Pictoral Diagram	2
1.2	UPGRADED SYSTEM	
	- Schematic	3
	- Pictorial Diagram	4
1.3	COST MODEL	
	- Table	5
2.0	SENATE	
2.1	PRESENT SYSTEM	
	- Schematic	6
	- Pictorial Diagram	7
2.2	UPGRADED SYSTEM	
	- Schematic	8
	- Pictorial Diagram	9
2.3	COST MODEL	
	- Table	10

NOTE: RESTRICTED DISTRIBUTION RECOMMENDED

The Budgetary Pricing Information provided herein and the model list of equipment from which the budgetary estimates were formed were developed for administrative purposes only. It is recommended that the distribution of this report be withheld from potential suppliers or contractors because:

- (A) Prior knowledge of budget limits may lead to less competitive pricing;
- (B) The model list of equipment may imply use of specific products whereas the bidder may have equally satisfactory and most cost effective alternatives to propose.

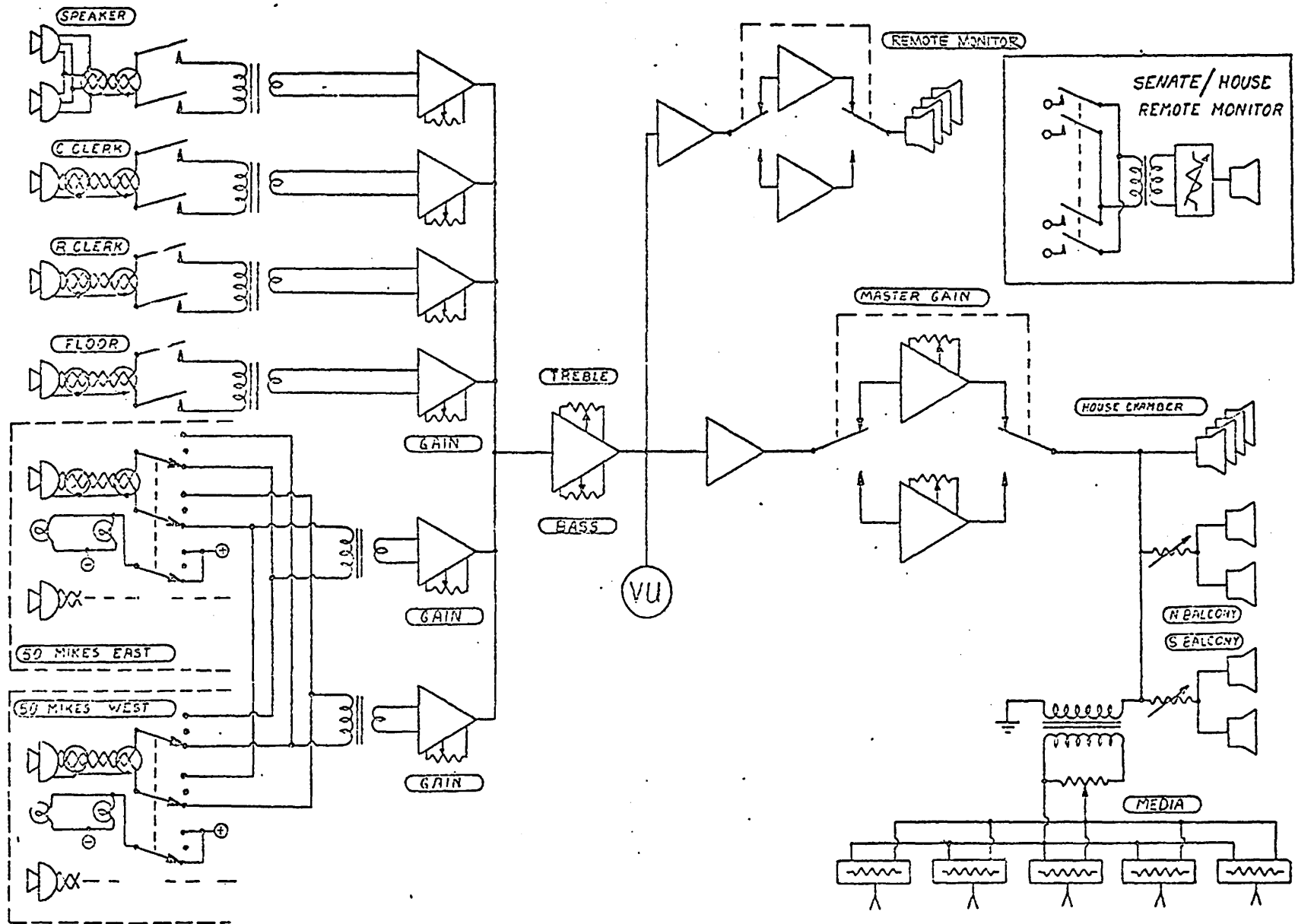
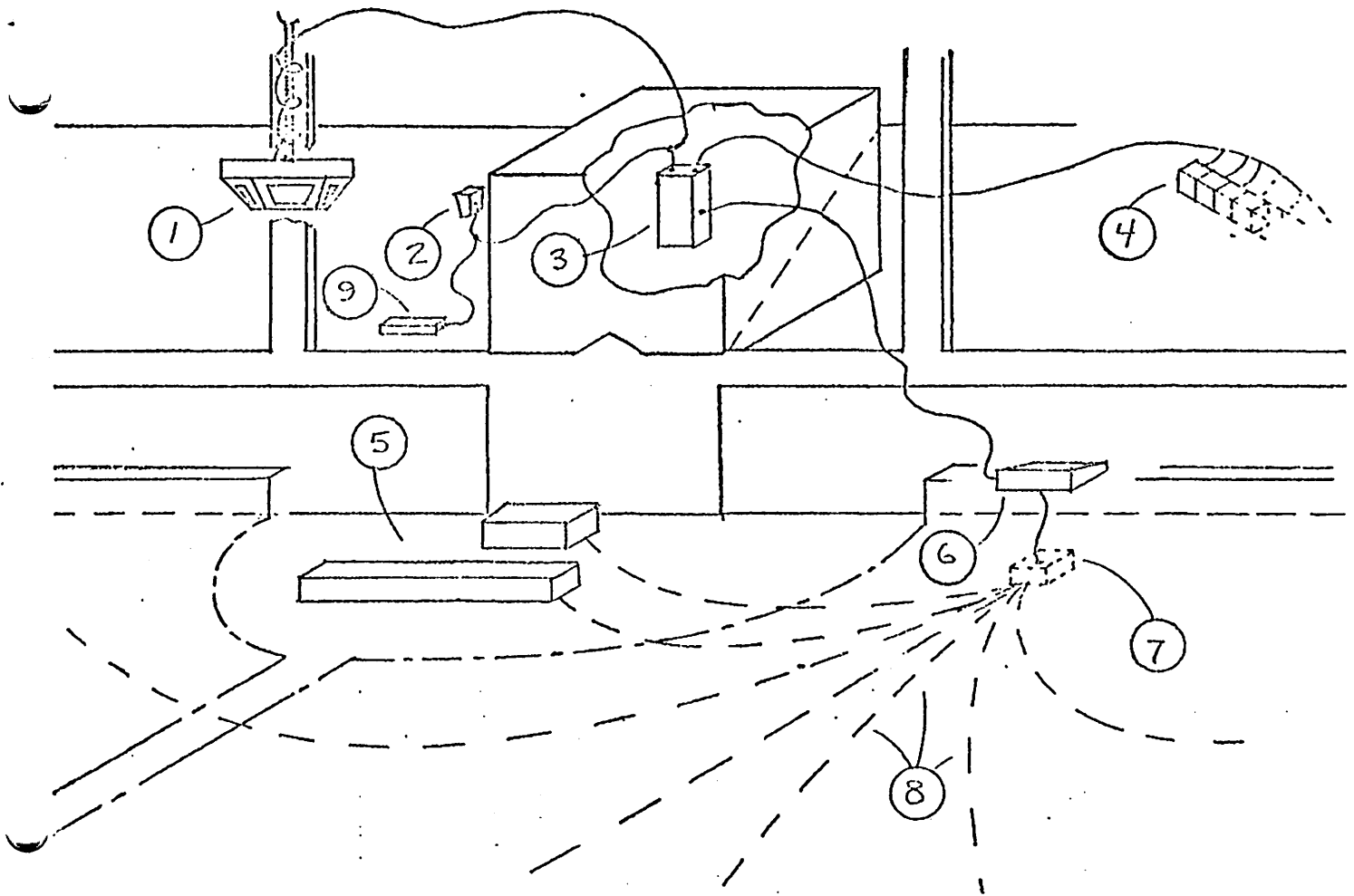

FIGURE 2.1
SCHEMATIC DIAGRAM - HOUSE OF REPRESENTATIVES



KEY:

1. "Gondola" Speakers
2. Balcony Speakers (N&S)
3. Equipment Rack
4. Remote Monitor Speakers
5. The "Well"
6. Audio Control Console
7. Collection Box (Under Floor)
8. Audio and Lamp Wires (Under Floor)
9. Media Taps

NOTE: The purpose of this illustration is to show the approximate physical location of major equipment items and the general wiring scheme, and not to depict precise quantities of components nor the exact wiring scheme.

FIGURE 2.2
HOUSE AUDIO SYSTEM - PRESENT CONFIGURATION

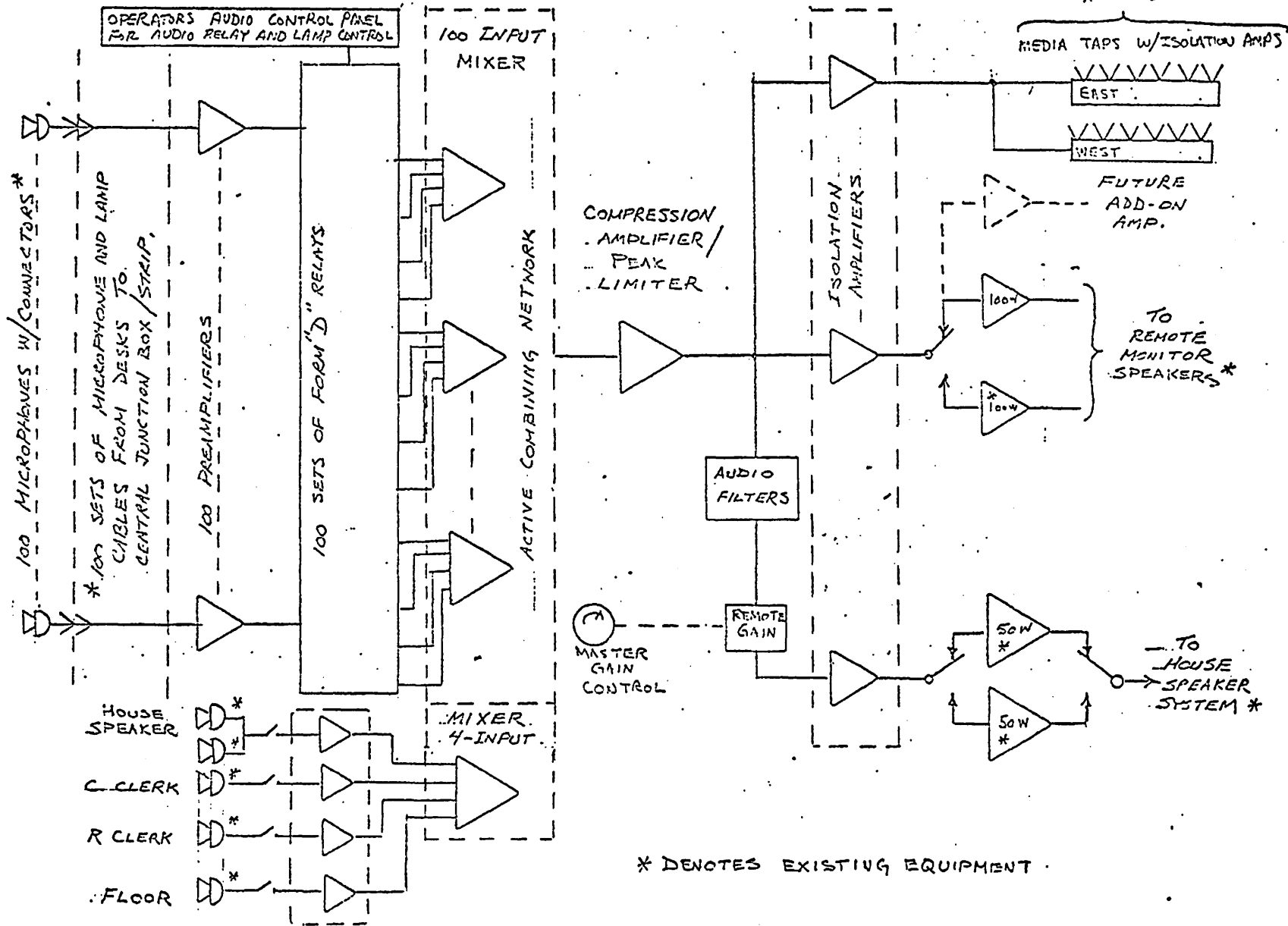
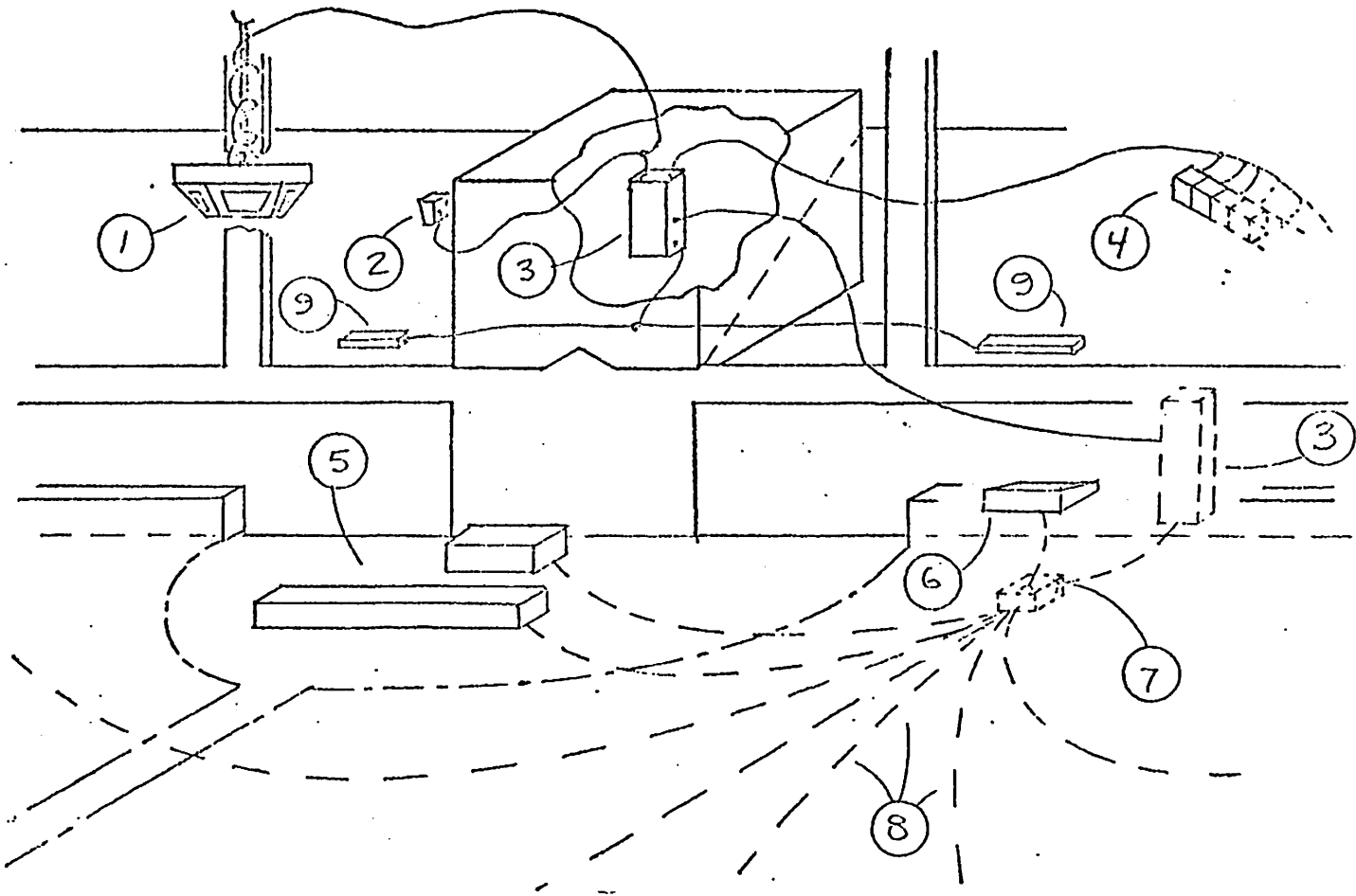

FIGURE 2.3
UPGRADED AUDIO SYSTEM - HOUSE



KEY:

1. "Gondola" Speakers
2. Balcony Speakers (N&S)
3. Equipment Rack
4. Remote Monitor Speakers
5. The "Well"
6. Audio Control Console
7. Collection Box (Under Floor)
8. Audio and Lamp wires (Under Floor)
9. Media Taps

NOTE: The purpose of this illustration is to show the approximate physical location of major equipment items and the general wiring scheme, and not to depict precise quantities of components nor the exact wiring scheme.

FIGURE 2.4

HOUSE AUDIO SYSTEM - UPGRADE CONFIGURATION

TABLE 2.2..
HOUSE AUDIO SYSTEM UPGRADE (Ref Fig. 2.3) COST
ESTIMATE (Budgetary)

Item*	QTY	Unit Cost	Total Cost
1) Microphone Preamps, solid state w/ transformer	104	\$ 90	\$ 9,360
2) Module Chassis Card Cage w/connectors	9	247	2,223
3) Cabinet Type Equipment Rack w/Door	2	330	660
4) Audio Mixer, 100 Input Group	1	440	440
5) Module Chassis, Card Cage w/connectors	2	247	494
6) Compression Amplifier w/Peak Limiter	1	385	385
7) Audio Mixer, 4 Input Group	1	39	39
8) Audio Filters, Narrow Band, Anti-Ring	4	116	464
9) 1/3 Octive Equalization Active Filter	1	880	880
10) Remote Gain Assembly, Main P.A.'s	2	26	52
11) Isolation Amplifier, Audio Distribution	3	22	66
12) Media Isolation Amplifiers	12	22	264
13) 100 Watt Power Amplifier, Remote Backup	1	407	407
14) Misc. Hardware, Wires, Switches, Fittings	A/R	550	550
15) Relay Assemblies, Daktronics, Form D	104	22	2,288
16) Power Supply, Regulated 24 vdc	1	385	385
17) Extend Audio/Lamp Leads Through Wall	Est.	Lot	1,650
18) Refurbish Control Console, Rewire	Est.	Lot	1,980
19) Labor for Existing System Removal, Installation, and Instruction in Use	Est.	Lot	2,310
20) Audio Level Balancing, General	Est	Lot	660
			\$ 25,557

* Item listing does not include existing equipment which is suitable for continued service (Microphones, certain Amplifiers, Power sources, Control Console Cabinet Assy, Gondola Speaker System and Like Items)

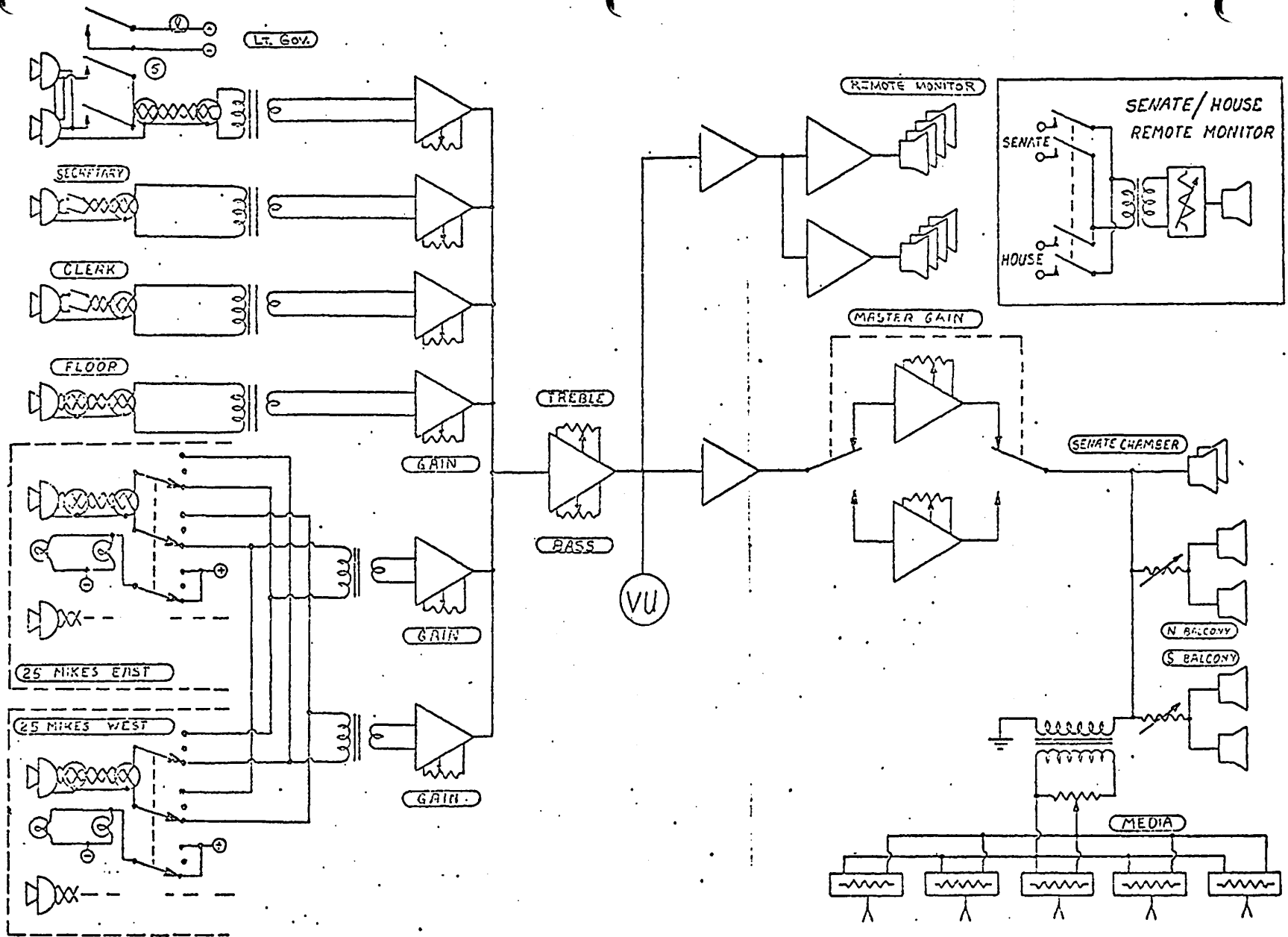
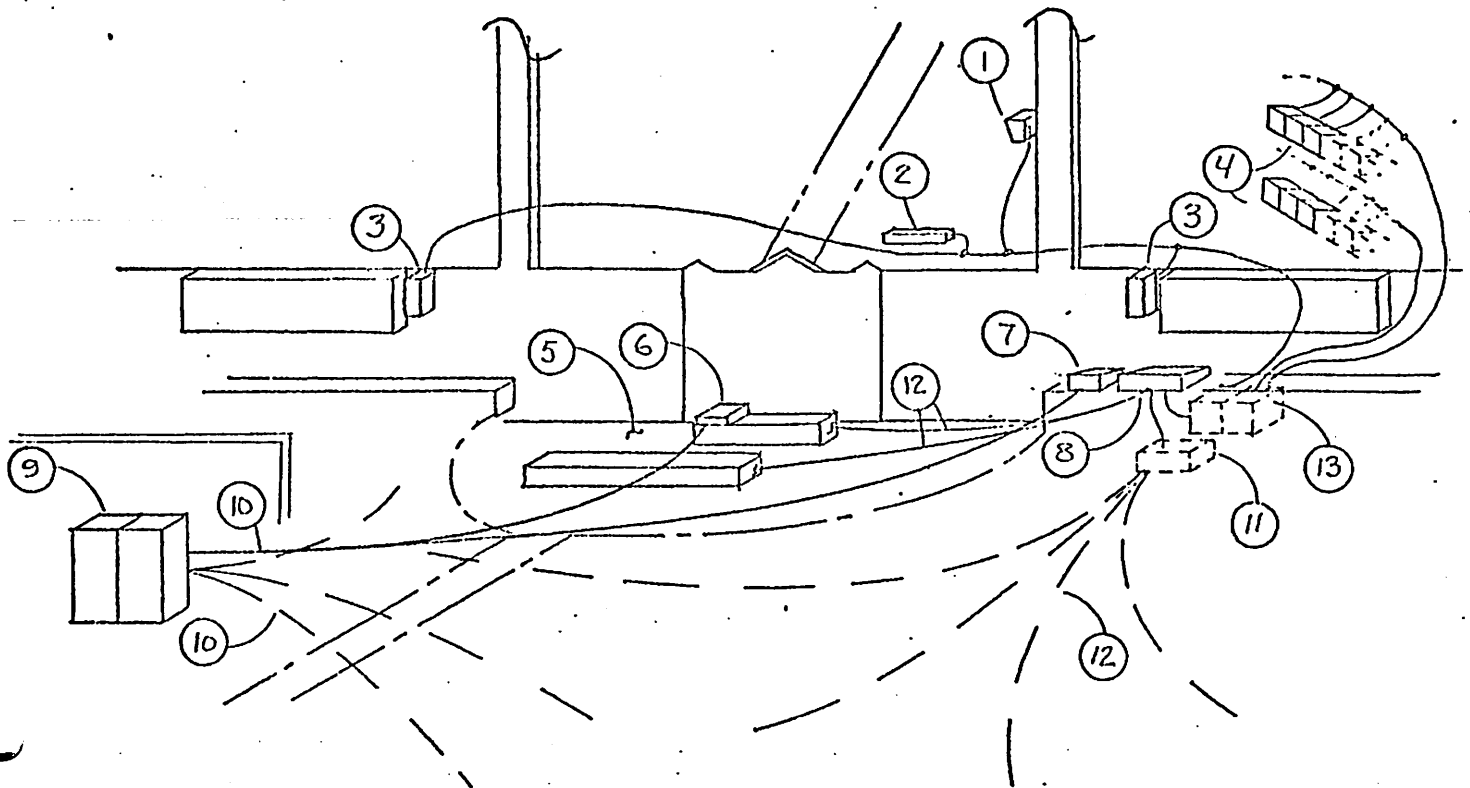

FIGURE 3.1

SCHEMATIC DIAGRAM - SENATE



KEY:

- | | |
|----------------------------|----------------------------|
| 1. Balcony Speakers | 8. Audio Control Panel |
| 2. Media Taps | 9. Daktronics Control Unit |
| 3. Column Speakers | 10. Voting and Lamp Wires |
| 4. Remote Monitor Speakers | 11. Collection Box |
| 5. The "Well" | 12. Audio and Lamp Wires |
| 6. Lt. Gov. Vote Console | 13. Equipment Racks |
| 7. Speak Lamp Control | |

NOTE: The purpose of this illustration is to show the approximate physical location of major equipment items and the general wiring scheme, and not to depict precise quantities of components nor the exact wiring scheme.

FIGURE 3.2
SENATE AUDIO SYSTEM - PRESENT CONFIGURATION

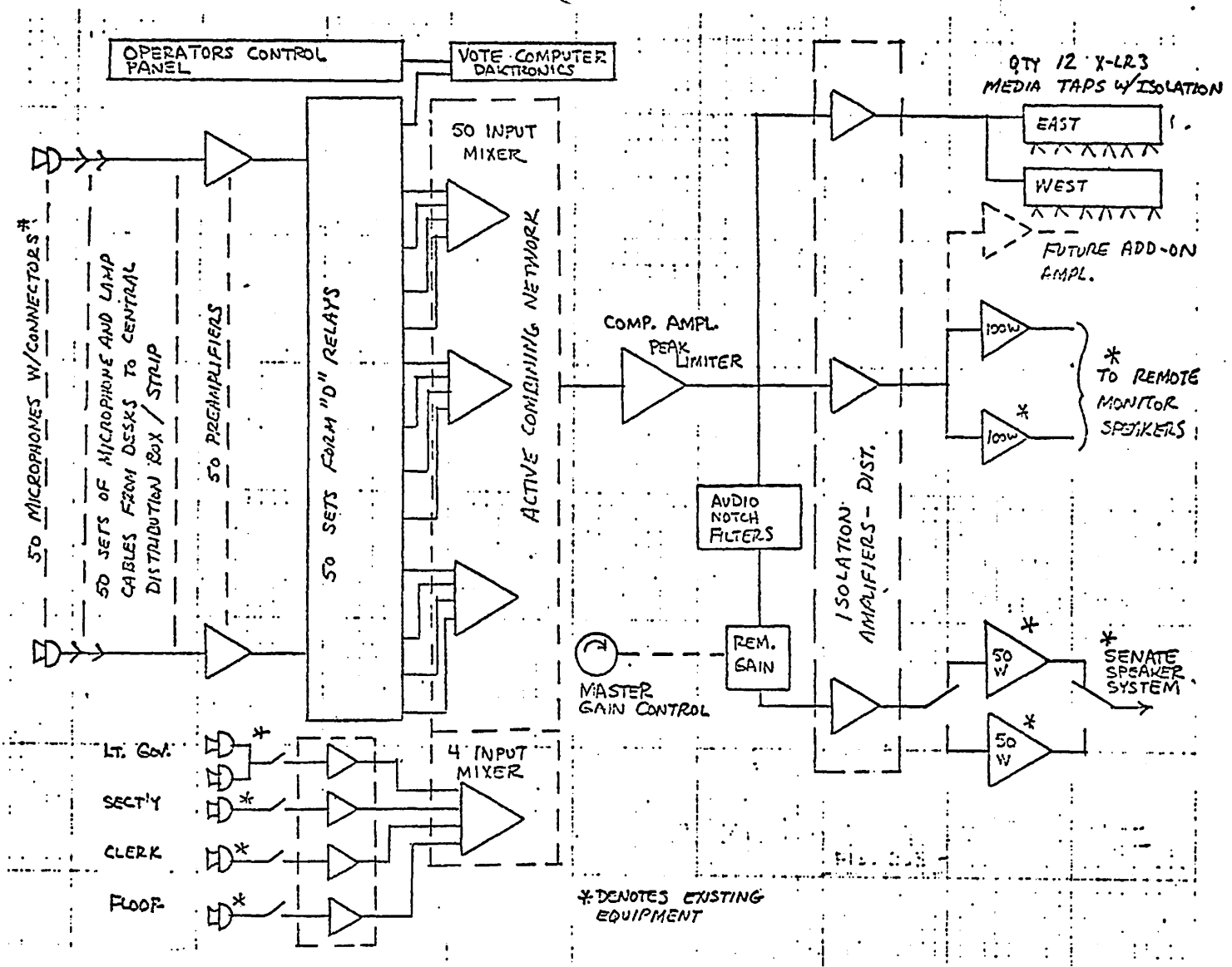
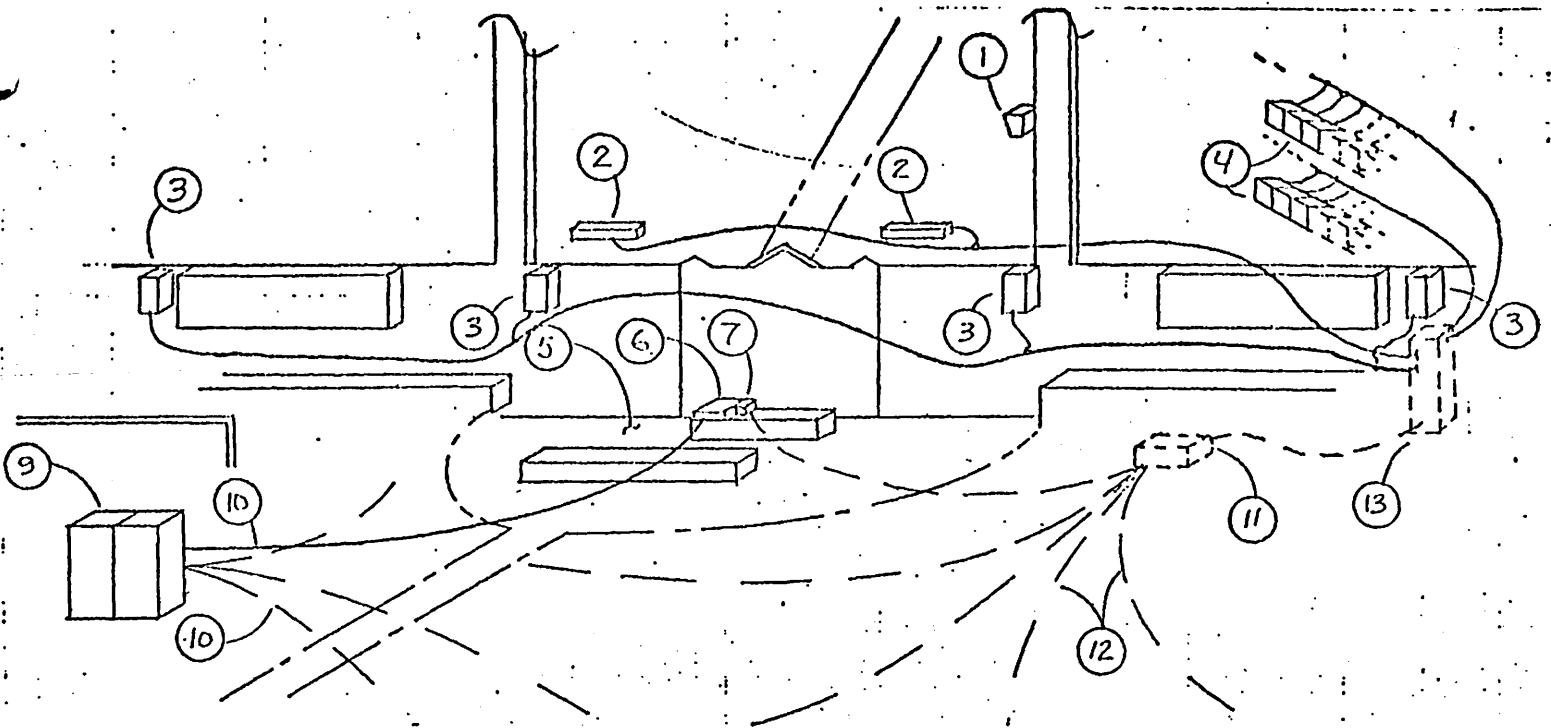

FIGURE 3.3

UPGRADED AUDIO SYSTEM - SENATE



KEY:

- | | |
|--------------------------------|----------------------------|
| 1. Balcony Speakers | 8. Daktronics Control Unit |
| 2. Media Taps | 9. Voting and Lamp Wires |
| 3. Column Speakers | 10. Collection Box |
| 4. Remote Monitor Speakers | 11. Audio and Lamp Wires |
| 5. The "Well" | 12. Equipment Racks |
| 6. Lt. Gov. Vote/Audio Console | |
| 7. Aux. Audio Control | |

NOTE: The purpose of this illustration is to show the approximate physical location of major equipment items and the general wiring scheme, and not to depict precise quantities of components nor the exact wiring scheme.

FIGURE 3.4
SENATE AUDIO SYSTEM - UPGRADE CONFIGURATION A

TABLE 3.2
SENATE AUDIO SYSTEM UPGRADE (Ref. Fig. 3.3) COST ESTIMATE (Budgetary)

Item*	Qty	Unit Cost	Total Cost	Alt. A	Alt. B
1) Microphone Preamps W/ transformers	54	\$ 90	\$ 4,860	\$ 4,860	\$ 4,860
2) Card Case W/Connectors	5	275	1,375	1,375	1,375
3) Cabinet Rack W/Door	1	330	330	330	330
4) Audio M-xer, 50 Input Group	1	319	319	319	319
5) Card Cage W/Connector	2	275	550	550	550
6) Comp. Ampl. W/Peak Limiter	1	385	385	385	385
7) Audio Mixer, 4 Input Group	1	39	39	39	39
8) Audio Filters, Narrow Band	4	116	464	464	464
9) 1/3 Octave Equalization Filter	1	880	880	880	880
10) Remote Gain Assy's	2	26	52	52	52
11) Isolation Ampl, Distribution	3	22	66	66	66
12) Isolation Ampl, Media	12	22	264	264	264
13) 100 W. Ampl. Replace Loaner	1	385	385	385	385
14) Misc. Hardware	A/R	440	440	440	440
15) Relay Assys, Daktronics Form D	54	22	1,188	1,188	1,188
16) Power Supply, Regulated 24 vdc	1	385	385	385	385
17) Extend Audio Lamp Leads Through Wall	Est.	Lot	1,980	1,650	1,650
18) Upgrade Lt. Gov. Console/ Daktronics	Est.	Lot	6,600	-	-
19) Upgrade Request Lamp Console/ Daktronics	Est.	Lot	-	4,950	-
20) Refurbish Audio Console/Rewire	Est.	Lot	220	220	1,540
21) Instl. Labor, General	Est.	Lot	1,980	1,980	1,980
22) Column Speakers	6	140	924	924	924
23) Sound Level Balancing, Speakers	Est.	250	275	275	275
24) Audio Level Balancing, General	Est.	400	440	440	440
			\$24,401	\$22,421	\$18,791

* Item listing does not include existing equipment which is suitable for continued service (Microphones certain Amplifiers, Power sources, Control Console Cabinet Assy, Gondola Speaker System, and Like Items).

REPORT OF THE
LEGISLATIVE FISCAL COMMITTEE
TO THE
LEGISLATIVE COUNCIL
JUNE 9, 1976

The Legislative Fiscal Committee of the Legislative Council met in the Fiscal Bureau Conference Room at 10:45 a.m., June 9, 1976. All members of the Fiscal Committee were present except Senator Nystrom and Senator Van Gilst.

Senator Palmer, Chairman, asked for suggestions of visitations for this interim. It was the consensus of the Committee that the chairmen of the visitation committees be contacted and that they present at the July meeting of the Fiscal Committee a list of suggested visitations. The Chairmen will be advised that the lists be kept to the very minimum and coordinated with the interim legislative studies.

After discussion of various topics that might be studied by the Fiscal Committee, it was moved that the Chairman be authorized to appoint a subcommittee to bring back to the Fiscal Committee suggestions to streamline and make more efficient the appropriation process.

Senator Palmer announced the resignation of David Bolender from the staff of the Fiscal Bureau. Mr. Bolender will be joining the Department of Social Services.

REPORT OF THE LEGISLATIVE SERVICE COMMITTEE

June 9, 1976

The Legislative Service Committee received salary recommendations for employees of the Legislative Service Bureau, the Legislative Fiscal Bureau, and the Office of the Citizens' Aide from the directors of the three agencies. It was determined that the Committee will hold an additional meeting prior to the July meeting of the Legislative Council in order to finalize its recommendations to the Legislative Council.

The Legislative Service Committee recommends that Jay Honeycutt and Michael Goedert both be employed by the Legislative Service Bureau in Attorney I positions to fill the vacancies created by the resignations of Robert Egge and Mark Soldat.

It is recommended that Serge Garrison be given the authority to enter into a lease-purchase agreement with Xerox Corporation for the ownership of a Xerox 7000 machine at an annual price approximately equal to the annual rental cost, which would pay for the machine over a five-year period and would provide a seven-year guarantee.

Summaries of travel for the last fiscal year and proposed travel for the next fiscal year were presented by the three directors. The Legislative Service Committee took no action on the travel policy.

The Committee recommends that the budget allocations for the Legislative Service Bureau and the Legislative Fiscal Bureau for the next fiscal year be approved as submitted by the directors pending approval of any salary increases and any future review by the Committee.

Respectfully submitted,

MINNETTE F. DODERER, Chairperson

REPORT OF THE STUDIES COMMITTEE TO THE LEGISLATIVE COUNCIL

June 9, 1976

The Studies Committee met at 11:00 a.m. in the Speaker's Conference Room. The members reviewed each of the study resolutions which had been distributed previously to the members of the Legislative Council and several requests which had been submitted to the Secretary of the Senate in writing. Upon completion of a review of the proposed studies, the Studies Committee agreed to meet at 10:00 a.m. on July 13, 1976 to finalize their recommendations regarding studies to be conducted during this interim. The Committee also agreed that the memberships of the proposed interim study committees might be determined at the July 13 meeting.

Respectfully submitted,

GEORGE R. KINLEY, Co-Chairperson

JEROME FITZGERALD, Co-Chairperson

SUMMARY OF TRAVEL BY LEGISLATIVE SERVICE BUREAU EMPLOYEES FOR
FISCAL YEAR 1975-1976

During the fiscal year 1975-76 the total travel expenditures to date for Legislative Service Bureau employees totals \$8,106. Approximately \$2,600 of this can be attributed to the Midwestern Conference which required 9 employees for periods before and after the conference.

During the year Bureau employees attended conferences on school aid, unemployment compensation, workmen's compensation, legislative oversight, land use planning, education for the handicapped, ethics and elections, taxation, suggested state legislation, and medical malpractice. The director and members of the bureau who are new to the staff normally attend a 1-day meeting in Chicago each year which involves members of the staffs of the twelve Midwestern states. Various staff problems and issues are discussed at this meeting and the staffs have an opportunity to meet each other which has proved to be useful when questions regarding other state legislation have arisen. Phil Burks and the director have each served on two NCSL committees during the past year. Phil has been a member of the Reapportionment Committee of the National Conference of State Legislatures and the National Conference of State Legislatures Ethics and Elections Committee. The director has served on the National Conference of State Legislatures Legislative Improvement and Modernization Committee and the Subcommittee on the Governing Structure of the National Conference of State Legislatures. Three members of the staff attended the National Conference held at Philadelphia; Mr. Garrison, Mr. Burks, and Mr. Koebernick. Two staff members attended the Congressional delegation meeting in Washington, D.C. A number of study committees required in-state travel by staff members because of meeting places.

PROPOSED TRAVEL FOR LEGISLATIVE SERVICE BUREAU EMPLOYEES FOR
FISCAL YEAR 1976-1977

It is somewhat difficult to project travel for Bureau employees for the fiscal year 1976-1977 because the permanent schedule of seminars issued by the National Conference of State Legislatures does not seem to contain many seminars which appear to be of value to Service Bureau staff members. Some of the seminars for the calendar year 1976 have already been held and were attended in some instances by Bureau members. Normally there are some seminars held which result from recent problems which have arisen in the states and are not scheduled a long time in advance. Perhaps some Bureau members will attend this type of conference. At least two and perhaps three members of the staff will attend the National Conference of State Legislatures in Kansas City. Two persons serve on committees which meet during this conference. The number of persons is dependent upon the subject matters of the meetings. Perhaps staff members will only attend a portion of such conference since the site is close. This again will depend on the subject matter.

One staff member will probably attend the Midwestern Conference of the Council of State Governments to be held in Minneapolis. Not more than two persons will attend the National Workmen's Compensation Conference to be held in Biloxi, Mississippi. Those persons who serve on National Committees will continue to attend their meetings when possible. One staff member will attend the meeting on suggested state legislation. Some staff members will attend the staff meeting in Chicago in the fall--normally the director and the new staff members or a staff member who has not previously had the opportunity to attend this conference.

Ten members of the staff of the Legislative Service Bureau must earn 15 hours of credit towards continuing legal education. Thus an attempt will be made to send lawyers to seminars and workshops which offer subject matter of value to the staff member so he or she can better serve the members of the general assembly, while at the same time earning credits for continuing legal education. For instance there is a seminar in Iowa City on criminal law which will give 16 hours of credit for continuing legal education. The subject matter appears extremely valuable to those two persons who

will be working on criminal law in the future and the director plans to send two persons to attend the conference. The National Conference on Workmen's Compensation also will provide 16 hours of continuing education credit. There are normally a tax conference and a "bridge-the-gap" programs sponsored by the Iowa State Bar Association held each year and if it appears that the subject matter will be valuable for use by staff members in their work, staff members will be sent to them. In any event staff members will have to meet their continuing legal education requirements whether it be to further the business of the legislature, or at their own expense to enrich their backgrounds in areas of law not of great interest to the general assembly. There will be instate travel associated with meetings of study committees.

The sum of \$7,000 is presently being allocated for travel by the Bureau which is \$3,000 less than in the present fiscal year. If it appears that such funds would be insufficient, a request for a further allocation of funds will be made to the Council.

SCHEDULE OF EVENTS

February 27-28	The Medical Malpractice Crisis	DALLAS TEXAS
March 24-27	Renewable Energy Conference	DENVER/NORTHERN COLORADO
April 5-7	State Revenue Sources	CHICAGO, ILLINOIS
May 17-21 April 28-30	State Special Education Finance Problems and Needs.	ATLANTA, GEORGIA
May 13-14	Legislative Oversight Seminar.	COLUMBUS, OHIO
May 26-28	Management Development for Legislative Staff.	DENVER, COLORADO
July 3-4	Fiscal Analysis Seminar.	DENVER, COLORADO
June 16-17	Legislative Leaders Seminar	VAIL, COLORADO
June 30-July 2	Leadership Staff Seminar	ST. PAUL, MINNESOTA
July 26-29	Advanced Policy Study Seminar	
August 30	Legislative Internship Workshop	KANSAS CITY, MISSOURI
September 21-25	Services and Security Seminar	ST. PAUL, MINNESOTA
October 3-8	Legislative Clerks and Secretaries	SAN FRANCISCO, CALIFORNIA
December 2-3	State Growth Policy	TAMPA, FLORIDA

LEGISLATIVE FISCAL BUREAU
 Schedule of Meetings, Training Seminars and Conferences
 Fiscal Year 1976

<u>Item</u>	<u>Sponsor</u>	<u>Place</u>	<u>Date 1975-76</u>	<u>Who Attended</u>
Fiscal Analysis Program	NCSL	Raleigh, N.C.	8-14-15	Rankin
Introductory Seminar in State Budgeting	NASBO	Ashville, N.C.	8-3	Faller Smith
Legislative Council Meeting with Congressional Dele.		Washington, D.C.	9-29	Rankin, Prouty
Annual Meeting & Seminars	NCSL	Philadelphia	10-7	Bolender Prouty, Rankin
Legislative Computer Analysis		Olympia	1-5	Farr, Prouty
Renewable Energy Conference	NCSL	Denver	3-24	Smith
Title XIX	NCSL	Chicago	4-24	Bolender
Intergovernmental Audit Forum		Kansas City	Quarterly	Rankin
Seminar on Performance Evaluation and Computer Analysis	AIPA	Washington, D.C.	4-19	Farr

LEGISLATIVE FISCAL BUREAU
 Schedule of Meetings, Training Seminars and Conferences
 Fiscal Year 1977

<u>Item</u>	<u>Sponsor</u>	<u>Place</u>	<u>Date</u>
Federally Assisted Programs	AICPA	Des Moines	June 28, 1976
Operational Auditing	Interagency Training Center	Chicago	August 2-13-76
Introductory Seminar in State Budgeting	NASBO	Kansas City	July 11-15-76
Operational Auditing	Association of Government Accts.	Philadelphia San Francisco	June 14-15-76 August 26-27-76
Workshop on Effectiveness Measurement Program	NASBO	Louisville	August 15-19-76
Annual Symposium	Association of Government Accts.	Philadelphia	June 16-18-76
Information Needs of Govt. Use of Performance Evaluation Performance Auditing	NASIS	Hersey, Pa.	August 16-18-76
Annual Meeting & Seminars	NCSL	Kansas City	August 31-76 Sept. 3-76
Intergovernmental Audit Forum		Kansas City	Quarterly