

**TRANSPORTATION DEPARTMENT[761]**

Rules transferred from agency number [820] to [761] to conform with the reorganization numbering scheme in general IAC Supp. 6/3/87.

*GENERAL*

**CHAPTERS 1 to 3**

Reserved

**CHAPTER 4**

**PUBLIC RECORDS AND FAIR INFORMATION PRACTICES**

(Uniform Rules)

- 4.1(22,305) General provisions
- 4.2(22) Statement of policy and purpose
- 4.3(22) Access to records
- 4.4(22) Access to confidential records
- 4.5(22) Consent to release a confidential record to a third party
- 4.6(22) Requests for confidential treatment
- 4.7(22) Procedure by which additions, dissents, or objections may be entered into records
- 4.8(22) Notice to suppliers of information
- 4.9(22) Confidential records

**CHAPTERS 5 to 9**

Reserved

**CHAPTER 10**

**ADMINISTRATIVE RULES**

- 10.1(17A) General
- 10.2(17A) Rule making
- 10.3(17A) Petitions for rule making

**CHAPTER 11**

**WAIVER OF RULES**

- 11.1(17A) Purpose and scope
- 11.2(17A) Authority to grant waiver
- 11.3(17A) Criteria, considerations and limitations
- 11.4(17A) Decision on waiver
- 11.5(17A) Petition for waiver
- 11.6(17A) Action on petition
- 11.7(17A) Modification or cancellation of waiver
- 11.8(17A) Records

**CHAPTER 12**

**DECLARATORY ORDERS**

- 12.1(17A) Definitions
- 12.2(17A) Petition for declaratory order
- 12.3(17A) Notice of petition
- 12.4(17A) Action on petition
- 12.5(17A) Effect of a declaratory order

**CHAPTER 13**

**CONTESTED CASES**

- 13.1(17A) Definitions
- 13.2(17A) Applicability
- 13.3(17A) Initiation of contested case
- 13.4(17A) Submission of request for informal settlement or hearing
- 13.5(17A) Informal settlement
- 13.6(17A) Contested case decision
- 13.7(17A) Appeal
- 13.8(17A) Motion for review
- 13.9(17A) Rehearings
- 13.10(17A) Maintenance of records
- 13.11(17A) Use of legal assistants or paralegals

|                |  |
|----------------|--|
| 13.12(17A)     | Communications   |
| 13.13(17A)     | Default  |
| 13.14 to 13.19 | Reserved   |
| 13.20(17A)     | Additional procedures when the department is not a party |

## CHAPTERS 14 to 19

Reserved

## CHAPTER 20

## PROCUREMENT OF EQUIPMENT, MATERIALS, SUPPLIES AND SERVICES

|            |   |
|------------|---|
| 20.1(307)  | Scope and applicability   |
| 20.2(307)  | Definitions   |
| 20.3(307)  | Procurement policy  |
| 20.4(307)  | Formal advertising procedures and requirements  |
| 20.5(307)  | Limited solicitation procedures and requirements  |
| 20.6(307)  | Professional and technical services   |
| 20.7(307)  | Sole source or emergency selection  |
| 20.8(307)  | Conflicts with federal requirements   |
| 20.9       | Reserved  |
| 20.10(307) | Negotiation—architectural, landscape architectural, engineering and related professional and technical services |

## CHAPTERS 21 to 24

Reserved

## CHAPTER 25

## COMPETITION WITH PRIVATE ENTERPRISE

|           |                |
|-----------|----------------|
| 25.1(23A) | Interpretation |
| 25.2(23A) | Exemptions     |

## CHAPTER 26

Reserved

## CHAPTER 27

## INTEREST ON RETAINED FUNDS

|           |                            |
|-----------|----------------------------|
| 27.1(573) | Interest on retained funds |
|-----------|----------------------------|

## CHAPTERS 28 to 39

Reserved

## CHAPTER 40

## RECOVERY OF DAMAGES TO HIGHWAYS OR HIGHWAY STRUCTURES

|           |                      |
|-----------|----------------------|
| 40.1(321) | Scope                |
| 40.2(321) | Definitions          |
| 40.3(321) | Information          |
| 40.4(321) | Accident scene       |
| 40.5(321) | Repair of facilities |
| 40.6(321) | Recovery of damages  |

## CHAPTERS 41 to 99

Reserved

*HIGHWAYS*

## CHAPTER 100

Reserved

## CHAPTER 101

## FARM-TO-MARKET REVIEW BOARD

|            |  |
|------------|--|
| 101.1(306) | Purpose  |
| 101.2(306) | Definitions  |
| 101.3(306) | Composition and membership of the farm-to-market review board            |
| 101.4(306) | Collection of system modification requests and frequency of meetings     |
| 101.5(306) | Procedure for requesting modifications to the farm-to-market road system |

|             |   |
|-------------|---|
| 101.6(306)  | Review criteria for determining eligibility for inclusion of additional roads into the farm-to-market road system |
| 101.7(306)  | Voting and approval of requested modifications  |
| 101.8(306)  | Report of board decision to applicant county  |
| 101.9(306)  | Reapplication for modification  |
| 101.10(306) | Judicial review   |
| 101.11(306) | Adoption and modification of rules  |
| 101.12(306) | Severability clause   |

#### CHAPTERS 102 to 104

Reserved

#### CHAPTER 105

#### HOLIDAY REST STOPS

|                |   |
|----------------|---|
| 105.1(307,314) | Purpose                                   |
| 105.2(307)     | General                                   |
| 105.3(307,314) | Conditions                                |
| 105.4(307,314) | Holiday rest stops on interstate highways |
| 105.5(307,314) | Holiday rest stops on primary highways    |

#### CHAPTERS 106 to 109

Reserved

#### *RIGHT-OF-WAY AND ENVIRONMENT*

#### CHAPTER 110

Reserved

#### CHAPTER 111

#### REAL PROPERTY ACQUISITION AND RELOCATION ASSISTANCE

|            |  |
|------------|--|
| 111.1(316) | Acquisition and relocation assistance manual |
|------------|--|

#### CHAPTER 112

#### PRIMARY HIGHWAY ACCESS CONTROL

|                     |   |
|---------------------|---|
| 112.1(306A,318)     | Scope and contact information                         |
| 112.2(306A,321)     | Definitions   |
| 112.3(306A)         | General provisions                                    |
| 112.4(17A,306A,318) | Permitting process                                    |
| 112.5(306A)         | Access types and the primary highway category system  |
| 112.6(306A)         | Location and design                                   |
| 112.7(306A)         | Access construction                                   |
| 112.8(306A)         | Drainage requirements for access connection approvals |
| 112.9(306A,318)     | Violations at access connections                      |

#### CHAPTERS 113 and 114

Reserved

#### CHAPTER 115

#### UTILITY ACCOMMODATION

|              |  |
|--------------|--|
| 115.1(306A)  | General information                                    |
| 115.2(306A)  | Definitions  |
| 115.3        | Reserved   |
| 115.4(306A)  | General requirements for occupancy of the right-of-way |
| 115.5(306A)  | General design provisions                              |
| 115.6(306A)  | Scenic enhancement                                     |
| 115.7(306A)  | Liability  |
| 115.8(306A)  | Utility accommodation permit                           |
| 115.9(306A)  | Traffic protection                                     |
| 115.10(306A) | Construction responsibilities and procedures           |
| 115.11(306A) | Vertical overhead clearance requirements               |
| 115.12(306A) | Utility facility attachments to bridges                |
| 115.13(306A) | Underground utility facilities                         |
| 115.14(306A) | Freeways   |
| 115.15(306A) | Transverse installations on freeways                   |

|                  |  |
|------------------|--|
| 115.16(306A)     | Longitudinal installations on freeways                         |
| 115.17(306A)     | Nonfreeway primary highways                                    |
| 115.18(306A)     | Longitudinal installations on nonfreeway primary highways      |
| 115.19(306A)     | Maintenance and emergency work                                 |
| 115.20(306A)     | Abandonment or removal of utility facilities                   |
| 115.21 to 115.24 | Reserved   |
| 115.25(306A)     | Utility facility adjustments for highway improvement projects  |
| 115.26(306A)     | Notice of project  |
| 115.27(306A)     | First plan submission, preliminary work plan and agreement     |
| 115.28(306A)     | Second plan submission, final work plan and permit application |
| 115.29(306A)     | Notice of work   |
| 115.30(306A)     | Miscellaneous adjustment provisions                            |

#### CHAPTER 116 JUNKYARD CONTROL

|             |                                 |
|-------------|---------------------------------|
| 116.1(306C) | Definitions                     |
| 116.2(306C) | Junkyards prohibited—exceptions |
| 116.3(306C) | Screening or removal            |
| 116.4(306C) | Acquisition                     |
| 116.5(306C) | Screening                       |
| 116.6(306C) | Nuisance—injunction             |
| 116.7(17A)  | Hearings and appeals            |
| 116.8(306C) | Contact information             |

#### CHAPTER 117 OUTDOOR ADVERTISING

|                       |  |
|-----------------------|--|
| 117.1(306B,306C)      | Definitions  |
| 117.2(306B,306C)      | General provisions   |
| 117.3(306B,306C,306D) | General criteria   |
| 117.4                 | Reserved   |
| 117.5(306B,306C)      | Location, size and spacing requirements                                      |
| 117.6(306C)           | Outdoor advertising permits and fees required                                |
| 117.7                 | Reserved   |
| 117.8(306B,306C)      | Removal procedures   |
| 117.9(306B,306C)      | Acquisition of advertising devices that have been issued provisional permits |
| 117.10(17A,306C)      | Contested cases  |

#### CHAPTER 118 LOGO SIGNING

|             |   |
|-------------|---|
| 118.1(306C) | Introduction  |
| 118.2(306C) | Definitions   |
| 118.3(306C) | Erection and location of specific service signs and placement of business signs |
| 118.4(306C) | Eligibility for placement of business signs on main line specific service signs |
| 118.5(306C) | Application, drawing, and fees  |
| 118.6(306C) | Business sign blank specifications  |
| 118.7(306C) | Business sign face specifications   |

#### CHAPTER 119 TOURIST-ORIENTED DIRECTIONAL SIGNING

|            |  |
|------------|--|
| 119.1(321) | Definitions  |
| 119.2(321) | General  |
| 119.3(321) | Eligibility requirements for a destination         |
| 119.4      | Reserved   |
| 119.5(321) | Application and approval procedure                 |
| 119.6(321) | Installation, maintenance, replacement and removal |

#### CHAPTERS 120 to 124 Reserved

#### CONSTRUCTION

#### CHAPTERS 125 to 129 Reserved

*TRAFFIC OPERATIONS*CHAPTER 130  
SIGNING MANUAL

130.1(321) Manual

CHAPTER 131  
SIGNING ON PRIMARY HIGHWAYS

131.1(321) Destination signs at an intersection  
 131.2(321) Erection of signs for numbered business routes  
 131.3(321) Erection of signs for schools  
 131.4(321) Erection of camping service signs on interstate highways  
 131.5(321) Erection of signs for sanitary landfills  
 131.6(321) Erection of signs for special events  
 131.7(321) Erection of signs for organized off-highway camps  
 131.8(321) Erection of signs for county conservation parks  
 131.9(321) Erection of no parking signs  
 131.10(321) Signing for named routes and memorial bridges  
 131.11(314) Signing for Iowa medal of honor highway  
 131.12 to 131.14 Reserved  
 131.15(321) Information and address

## CHAPTERS 132 to 134

Reserved

## CHAPTER 135

WARNING LIGHTS ON VEHICLES OR EQUIPMENT NOT OWNED AND OPERATED BY THE  
DEPARTMENT WHEN USED IN ROAD WORK ZONES

135.1(321) Warning lights on vehicles or equipment in road work zones

## CHAPTER 136

## LIGHTING

136.1(306,318) Lighting of primary-secondary intersections  
 136.2(306,318) Destination lighting  
 136.3 to 136.5 Reserved  
 136.6(306,318) Warrants and design requirements for lighting

## CHAPTERS 137 to 139

Reserved

## CHAPTER 140

TRAFFIC SIGNALS AND BEACONS  
ON PRIMARY ROADS

140.1(321) Erection of traffic signals and beacons on primary highways

## CHAPTER 141

Reserved

## CHAPTER 142

## SPEED ZONING ON PRIMARY HIGHWAYS

142.1(321) Adjustment of speed zones on primary highways

## CHAPTER 143

## TRAFFIC SIGNAL SYNCHRONIZATION

143.1(364) Definitions  
 143.2(364) Applicability  
 143.3 Reserved  
 143.4(364) Required synchronization

## CHAPTERS 144 to 149

Reserved

*PRIMARY ROAD EXTENSIONS*

CHAPTER 150  
IMPROVEMENTS AND MAINTENANCE ON PRIMARY ROAD EXTENSIONS

|            |   |
|------------|---|
| 150.1(306) | Definitions   |
| 150.2(306) | Improvements and maintenance on extensions of freeways                    |
| 150.3(306) | Improvements and maintenance on extensions of nonfreeway primary highways |
| 150.4(306) | General requirements for primary road extensions                          |
| 150.5(307) | Special circumstances   |

CHAPTER 151  
CITY REQUESTS FOR CLOSURE OF  
PRIMARY ROAD EXTENSIONS

|            |                                 |
|------------|---------------------------------|
| 151.1(321) | Closing primary road extensions |
|------------|---------------------------------|

CHAPTERS 152 to 159  
Reserved

*SPECIAL HIGHWAY PROGRAMS*

CHAPTER 160  
COUNTY AND CITY BRIDGE CONSTRUCTION FUNDS

|            |                         |
|------------|-------------------------|
| 160.1(312) | Purpose                 |
| 160.2(312) | Contact information     |
| 160.3(312) | Source of funds         |
| 160.4(312) | Administration of funds |

CHAPTER 161  
Reserved

CHAPTER 162  
SURFACE TRANSPORTATION BLOCK GRANT PROGRAM

|            |                         |
|------------|-------------------------|
| 162.1(307) | Purpose                 |
| 162.2(307) | Information             |
| 162.3(307) | Source of funds         |
| 162.4(313) | Swapping of funds       |
| 162.5(307) | Administration of funds |

CHAPTER 163  
RISE PROGRAM

|             |   |
|-------------|---|
| 163.1(315)  | Definitions   |
| 163.2(315)  | Information and forms   |
| 163.3(315)  | Purpose of RISE program   |
| 163.4(315)  | Administration of RISE program  |
| 163.5(315)  | Source, allocation, and use of RISE funds   |
| 163.6(315)  | Project financing and funding shares  |
| 163.7(315)  | Eligibility of applicants and joint applications  |
| 163.8(315)  | Project activities eligible and ineligible for RISE funds   |
| 163.9(315)  | Advance eligibility of land acquisition and preliminary design costs incurred prior to funding commitment by commission |
| 163.10(315) | Immediate opportunity projects  |
| 163.11(315) | Local development projects  |
| 163.12(315) | Project administration  |

CHAPTER 164  
TRAFFIC SAFETY IMPROVEMENT PROGRAM

|            |                            |
|------------|----------------------------|
| 164.1(312) | Definitions                |
| 164.2(312) | Information and forms      |
| 164.3(312) | Program administration     |
| 164.4(312) | Applicant eligibility      |
| 164.5(312) | Project eligibility        |
| 164.6(312) | Eligible project costs     |
| 164.7(312) | Ineligible project costs   |
| 164.8(312) | Applications               |
| 164.9(312) | Processing the application |

164.10(312) Project agreement

CHAPTER 165  
RECREATIONAL TRAILS PROGRAM

|                   |   |
|-------------------|---|
| 165.1(465B)       | Definitions   |
| 165.2(465B)       | Information and forms   |
| 165.3 and 165.4   | Reserved  |
| 165.5(465B)       | Program administration  |
| 165.6 to 165.8    | Reserved  |
| 165.9(465B)       | Applicant eligibility   |
| 165.10 and 165.11 | Reserved  |
| 165.12(465B)      | Project eligibility   |
| 165.13 and 165.14 | Reserved  |
| 165.15(465B)      | Eligible project costs  |
| 165.16            | Reserved  |
| 165.17(465B)      | Ineligible project costs  |
| 165.18            | Reserved  |
| 165.19(465B)      | Advance eligibility of land acquisition and preliminary design costs incurred prior to funding commitment by commission |
| 165.20 and 165.21 | Reserved  |
| 165.22(465B)      | Application   |
| 165.23(465B)      | Application procedure   |
| 165.24 and 165.25 | Reserved  |
| 165.26(465B)      | Evaluation and approval   |
| 165.27 to 165.29  | Reserved  |
| 165.30(465B)      | Project agreement   |
| 165.31 and 165.32 | Reserved  |
| 165.33(465B)      | Noncompliance   |

CHAPTERS 166 to 169  
Reserved

*LOCAL SYSTEMS*

CHAPTERS 170 to 177  
Reserved

CHAPTER 178  
PROJECT COST REPORTING REQUIREMENTS  
FOR CITIES AND COUNTIES

|            |  |
|------------|--|
| 178.1(314) | Purpose  |
| 178.2(314) | Contact information                                    |
| 178.3(314) | Definitions  |
| 178.4(314) | Detailed instructions furnished to cities and counties |
| 178.5(314) | Project reporting                                      |

CHAPTER 179  
Reserved

CHAPTER 180  
QUOTATION PROCESS FOR GOVERNMENTAL ENTITIES FOR PUBLIC IMPROVEMENT  
FOR VERTICAL INFRASTRUCTURE

|               |  |
|---------------|--|
| 180.1(314)    | Purpose  |
| 180.2(314)    | Contact information  |
| 180.3(26,314) | Definitions  |
| 180.4         | Reserved   |
| 180.5(314)    | Solicitation of quotations                                 |
| 180.6(314)    | Submission of competitive quotation by governmental entity |
| 180.7(314)    | Form and content of competitive quotations                 |
| 180.8(314)    | Evaluation of competitive quotations                       |
| 180.9(314)    | Award of contract and subsequent procedures                |
| 180.10(314)   | Retained funds   |

CHAPTER 181  
STATEWIDE STANDARD FOR PERMITTING  
CERTAIN IMPLEMENTS OF HUSBANDRY

181.1(321) Statewide standard

CHAPTERS 182 to 300  
Reserved

CHAPTER 301  
DRIVER'S PRIVACY PROTECTION—MOTOR VEHICLE RECORDS

301.1(321) Applicability  
301.2(321) Adoption  
301.3(321) Definitions  
301.4(17A) Information and addresses  
301.5(321) Requirements and procedures  
301.6(321) Electronic motor vehicle records files  
301.7(321,321A) Certified abstract of operating records

CHAPTERS 302 to 379  
Reserved

CHAPTER 380  
MOTOR VEHICLES OPERATED BY AN AUTOMATED DRIVING SYSTEM

380.1(321) Applicability  
380.2(321) Definitions  
380.3(17A) Information and addresses  
380.4(321) Identification of driverless-capable vehicles in registration  
380.5(321) Operational restrictions  
380.6(321) Identification of driverless-capable vehicle networks  
380.7(17A,321) Driverless-capable vehicle exemption

CHAPTERS 381 to 399  
Reserved

CHAPTER 400  
VEHICLE REGISTRATION AND CERTIFICATE OF TITLE

400.1(321,322,544) Definitions  
400.2(321,322) Vehicle registration, certificate of title, receipt, validation sticker and registration plates—general provisions  
400.3(321) Application for certificate of title or registration for a vehicle  
400.4(321) Supporting documents required  
400.5(321) Where to apply for registration or certificate of title  
400.6(17A) Addresses, information and forms  
400.7(321) Information appearing on title or registration  
400.8(321) Release form for cancellation of security interest  
400.9 Reserved  
400.10(321) Assignment of security interest  
400.11(321) Sheriff's levy, restitution lien, and forfeiture lien noted as security interests  
400.12(321) Replacement certificate of title  
400.13(321) Bond required before title issued  
400.14(321) Transfer of ownership  
400.15(321) Cancellation of a certificate of title  
400.16(321) Application for certificate of title or original registration for a specially constructed, reconstructed, street rod or replica motor vehicle  
400.17 and 400.18 Reserved  
400.19(321) Temporary use of vehicle without plates or registration card  
400.20(321) Registration of motor vehicle weighing 55,000 pounds or more  
400.21(321) Registration of vehicles on a restricted basis  
400.22(321) Transfers of ownership by operation of law  
400.23(321) Junked vehicle  
400.24(321) New vehicle registration fee  
400.25(321) Fees established by the department  
400.26(321) Anatomical gift

|                   |  |
|-------------------|--|
| 400.27(321,322)   | Vehicles held for resale or trade by dealers   |
| 400.28(321)       | Special trucks   |
| 400.29            | Reserved   |
| 400.30(321)       | Registration of vehicles registered in another state or country                            |
| 400.31            | Reserved   |
| 400.32(321)       | Vehicles owned by nonresident members of the armed services                                |
| 400.33 and 400.34 | Reserved   |
| 400.35(321)       | Registration of vehicles equipped for persons with disabilities                            |
| 400.36(321)       | Land and water-type travel trailers registration fee                                       |
| 400.37(321)       | Motorcycle or autocycle primarily designed or converted to transport property              |
| 400.38            | Reserved   |
| 400.39(321)       | Conversion of motor vehicles   |
| 400.40(321)       | Manufactured or mobile home converted to or from real property                             |
| 400.41            | Reserved   |
| 400.42(321)       | Church bus registration fee  |
| 400.43(321)       | Storage of vehicles  |
| 400.44(321)       | Penalty on registration fees   |
| 400.45(321)       | Suspension, revocation or denial of registration   |
| 400.46(321)       | Termination of suspension of registration  |
| 400.47(321)       | Raw farm products  |
| 400.48 and 400.49 | Reserved   |
| 400.50(321,326)   | Refund of registration fees  |
| 400.51(321)       | Assigned identification numbers  |
| 400.52(321)       | Odometer statement   |
| 400.53(321)       | Stickers   |
| 400.54(321)       | Registration card issued for trailer-type vehicles   |
| 400.55(321)       | Damage disclosure statement  |
| 400.56(321)       | Hearings   |
| 400.57            | Reserved   |
| 400.58(321)       | Motorized bicycles   |
| 400.59(321)       | Registration documents lost or damaged in transit through the United States postal service |
| 400.60(321)       | Credit of registration fees  |
| 400.61(321)       | Reassignment of registration plates  |
| 400.62(321)       | Storage of registration plates, certificate of title forms and registration forms          |
| 400.63(321)       | Disposal of surrendered registration plates  |
| 400.64(321)       | County treasurer's report of motor vehicle collections and funds                           |
| 400.65 to 400.69  | Reserved   |
| 400.70(321)       | Removal of registration and plates by peace officer under financial liability coverage law |
| 400.71            | Reserved   |
| 400.72(321)       | Electronic lien and title  |

#### CHAPTER 401 SPECIAL REGISTRATION PLATES

|                 |   |
|-----------------|---|
| 401.1(321)      | Definition  |
| 401.2(321)      | Application, issuance and renewal   |
| 401.3           | Reserved  |
| 401.4(321)      | Gift certificates   |
| 401.5(321)      | Amateur radio call letter plates  |
| 401.6(321)      | Personalized plates   |
| 401.7(321)      | Collegiate plates   |
| 401.8(321)      | Medal of Honor plates   |
| 401.9(321)      | Firefighter plates  |
| 401.10(321)     | Emergency medical services plates   |
| 401.11(321)     | Natural resources plates  |
| 401.12(321)     | Blackout plates   |
| 401.13(321)     | Disabled veteran plates   |
| 401.14(321)     | Flying our colors plates  |
| 401.15(17A,321) | Nonprofit organization decal  |
| 401.16(17A,321) | Special plates with space reserved for a nonprofit organization decal   |
| 401.17          | Reserved  |
| 401.18(321)     | Combat infantryman badge, combat action badge, combat action ribbon, air force combat action medal, combat medical badge, fallen peace officers and civil war sesquicentennial plates |

|                  |  |
|------------------|--|
| 401.19(321)      | Legion of Merit plates                           |
| 401.20(321)      | Persons with disabilities plates                 |
| 401.21(321)      | Ex-prisoner of war plates                        |
| 401.22(321)      | National guard plates                            |
| 401.23(321)      | Pearl Harbor plates                              |
| 401.24(321)      | Purple Heart, Silver Star and Bronze Star plates |
| 401.25(321)      | U.S. armed forces retired plates                 |
| 401.26 to 401.30 | Reserved   |
| 401.31(321)      | Veteran plates                                   |
| 401.32(321)      | Surrender of plates                              |
| 401.33(321)      | Validation fees                                  |
| 401.34(321)      | Reassignment of plates                           |
| 401.35(321)      | Revocation of special registration plates—appeal |
| 401.36(321)      | Refund of fees                                   |

## CHAPTERS 402 to 404

Reserved

## CHAPTER 405

## SALVAGE

|                  |   |
|------------------|---|
| 405.1(321)       | Applicability                             |
| 405.2(321,321H)  | Definitions                               |
| 405.3(321)       | Salvage title                             |
| 405.4 and 405.5  | Reserved                                  |
| 405.6(321)       | Iowa salvage title required               |
| 405.7(321)       | Converting salvage title to regular title |
| 405.8(321)       | Foreign vehicles                          |
| 405.9(321)       | Records check                             |
| 405.10(321,322G) | Designations                              |
| 405.11 to 405.14 | Reserved                                  |
| 405.15(321)      | Salvage theft examination                 |

## CHAPTERS 406 to 409

Reserved

## CHAPTER 410

## SPECIAL MOBILE EQUIPMENT

|             |  |
|-------------|--|
| 410.1(321)  | General  |
| 410.2(321E) | Special mobile equipment transported on a registered vehicle |

## CHAPTER 411

## PERSONS WITH DISABILITIES PARKING PERMITS

|             |   |
|-------------|---|
| 411.1(321L) | Information and applications  |
| 411.2(321L) | Definitions   |
| 411.3(321L) | Application for persons with disabilities parking permit              |
| 411.4(321L) | Removable windshield placards   |
| 411.5(321L) | Persons with disabilities special registration plate parking stickers |
| 411.6(321L) | Persons with disabilities special registration plates                 |
| 411.7(321L) | Return of persons with disabilities parking permit                    |
| 411.8(321L) | Revocation of a persons with disabilities parking permit              |
| 411.9(321L) | Appeal  |

## CHAPTERS 412 to 423

Reserved

## CHAPTER 424

## TRANSPORTER PLATES

|                 |                    |
|-----------------|--------------------|
| 424.1(321)      | General            |
| 424.2 and 424.3 | Reserved           |
| 424.4(321)      | Transporter plates |

CHAPTER 425  
MOTOR VEHICLE AND TOWABLE RECREATIONAL VEHICLE DEALERS,  
MANUFACTURERS, DISTRIBUTORS AND WHOLESALERS

|                   |   |
|-------------------|---|
| 425.1(322)        | Introduction  |
| 425.2             | Reserved  |
| 425.3(322)        | Definitions   |
| 425.4 to 425.9    | Reserved  |
| 425.10(322)       | Application for dealer's license                                  |
| 425.11(322)       | Motor vehicle dealer licensing for final-stage manufacturers      |
| 425.12(322)       | Motor vehicle dealer's principal place of business                |
| 425.13(321,322)   | Business records of a motor vehicle dealer with multiple licenses |
| 425.14(322)       | Towable recreational vehicle dealer's place of business           |
| 425.15 and 425.16 | Reserved  |
| 425.17(322)       | Extension lot license   |
| 425.18(322)       | Supplemental statement of changes                                 |
| 425.19            | Reserved  |
| 425.20(322)       | Fleet vehicle sales and retail auction sales                      |
| 425.21 to 425.23  | Reserved  |
| 425.24(322)       | Miscellaneous requirements  |
| 425.25            | Reserved  |
| 425.26(322)       | State fair, fairs, shows and exhibitions                          |
| 425.27 and 425.28 | Reserved  |
| 425.29(322)       | Classic car permit  |
| 425.30(322)       | Motor truck display permit  |
| 425.31(322)       | Firefighting and rescue show permit                               |
| 425.32 to 425.39  | Reserved  |
| 425.40(322)       | Salespersons of dealers   |
| 425.41 to 425.49  | Reserved  |
| 425.50(322)       | Manufacturers, distributors, and wholesalers                      |
| 425.51 and 425.52 | Reserved  |
| 425.53(322)       | Wholesaler's financial liability coverage                         |
| 425.54 to 425.59  | Reserved  |
| 425.60(322)       | Right of inspection   |
| 425.61            | Reserved  |
| 425.62(322)       | Denial, suspension or revocation                                  |
| 425.63 to 425.69  | Reserved  |
| 425.70(321)       | Dealer plates   |
| 425.71            | Reserved  |
| 425.72(321)       | Demonstration permits   |

CHAPTERS 426 to 429

Reserved

CHAPTER 430  
MOTOR VEHICLE LEASING LICENSES

|             |                            |
|-------------|----------------------------|
| 430.1(321F) | General                    |
| 430.2(321F) | Application                |
| 430.3(321F) | Supplemental statements    |
| 430.4(321F) | Separate licenses required |

CHAPTER 431  
VEHICLE RECYCLERS

|             |   |
|-------------|---|
| 431.1(321H) | General                                     |
| 431.2(321H) | Criteria for a vehicle recycler license     |
| 431.3(321H) | Application                                 |
| 431.4(321H) | Firm name                                   |
| 431.5(321H) | Denial, suspension or revocation of license |
| 431.6(321)  | Right of inspection                         |

CHAPTERS 432 to 449

Reserved

CHAPTER 450  
MOTOR VEHICLE EQUIPMENT

|            |  |
|------------|--|
| 450.1(321) | Addresses, information and forms   |
| 450.2(321) | Equipment requirements for specially constructed, reconstructed, street rod, and replica motor vehicles, other than autocycles, motorcycles and motorized bicycles |
| 450.3(321) | Mud and snow tire  |
| 450.4(321) | Minimum requirements for constructing and equipping specially constructed or reconstructed motorcycles or motorized bicycles                                       |
| 450.5(321) | Minimum requirements for constructing and equipping specially constructed or reconstructed autocycles  |
| 450.6      | Reserved   |
| 450.7(321) | Front windshields, windows or sidewings  |

CHAPTER 451  
EMERGENCY VEHICLE CERTIFICATE

|                |  |
|----------------|--|
| 451.1(321)     | Information                                  |
| 451.2(321)     | Authorized emergency vehicle certificate     |
| 451.3(17A,321) | Application denial or certificate revocation |

CHAPTERS 452 and 453  
Reserved

CHAPTER 454  
TOWING WRECKED OR DISABLED VEHICLES

|            |             |
|------------|-------------|
| 454.1(321) | Definitions |
|------------|-------------|

CHAPTERS 455 to 479  
Reserved

CHAPTER 480  
ABANDONED VEHICLES

|            |                          |
|------------|--------------------------|
| 480.1(321) | Definitions              |
| 480.2(321) | Location                 |
| 480.3(321) | General requirements     |
| 480.4(321) | Advertising              |
| 480.5(321) | Bidder registry          |
| 480.6(321) | Odometer statement       |
| 480.7(321) | Abandoned vehicle report |
| 480.8(321) | Time limits              |

CHAPTERS 481 to 499  
Reserved

*MOTOR CARRIERS*

CHAPTER 500  
INTERSTATE REGISTRATION AND OPERATION OF VEHICLES

|                   |   |
|-------------------|---|
| 500.1(326)        | Definitions   |
| 500.2(17A,326)    | General information   |
| 500.3(17A,326)    | Waiver of rules   |
| 500.4(326)        | Renewal for IRP registration  |
| 500.5(321)        | Deadline for placing a vehicle in storage                                       |
| 500.6(321,326)    | Payment, delinquency and suspension   |
| 500.7(326)        | Self-certification of IRP registration plate and validation sticker destruction |
| 500.8(326)        | IRP credentials   |
| 500.9(326)        | Nonrenewal vehicle additions  |
| 500.10(326)       | Nonrenewal vehicle deletions  |
| 500.11(326)       | Voluntary cancellation of registration  |
| 500.12(326)       | Policy on registration credit   |
| 500.13(326)       | Penalty for late filing of vehicle schedule                                     |
| 500.14 to 500.16  | Reserved  |
| 500.17(326)       | Duplicate credentials   |
| 500.18 and 500.19 | Reserved  |

|             |   |
|-------------|---|
| 500.20(326) | Making claim for refund                       |
| 500.21      | Reserved                                      |
| 500.22(326) | Registration of vehicles with non-Iowa titles |
| 500.23(326) | Record retention                              |
| 500.24(326) | Trip permits                                  |
| 500.25(326) | Electronic information                        |

## CHAPTERS 501 to 504

Reserved

## CHAPTER 505

## INTERSTATE MOTOR VEHICLE FUEL LICENSES AND PERMITS

|             |                         |
|-------------|-------------------------|
| 505.1(452A) | Definitions             |
| 505.2(452A) | General information     |
| 505.3(452A) | General stipulations    |
| 505.4(452A) | Quarterly reports       |
| 505.5(452A) | Audits—required reports |
| 505.6(452A) | Hearings                |

## CHAPTERS 506 to 510

Reserved

## CHAPTER 511

SPECIAL PERMITS FOR OPERATION AND MOVEMENT OF  
VEHICLES AND LOADS OF EXCESS SIZE AND WEIGHT

|                      |  |
|----------------------|--|
| 511.1(321E)          | Definitions  |
| 511.2(321E)          | Location and general information   |
| 511.3(321E)          | Movement under permit  |
| 511.4(321E)          | Permits  |
| 511.5(321,321E)      | Fees and charges   |
| 511.6(321E)          | Insurance and bonds  |
| 511.7(321,321E)      | Annual oversize permits  |
| 511.8(321,321E)      | Annual oversize/overweight permits   |
| 511.9(321,321E)      | Annual all-systems oversize permits  |
| 511.10(321,321E)     | Annual all-systems overweight permits  |
| 511.11(321,321E)     | Multitrip permits  |
| 511.12(321E)         | Compacted rubbish vehicle permits  |
| 511.13(321,321E)     | Single-trip permits  |
| 511.14(321,321E)     | Annual raw forest products permits   |
| 511.15(29C,321,321E) | Emergency interstate permit  |
| 511.16(321,321E)     | Annual fluid milk products permits   |
| 511.17(321,321E)     | Maximum axle weights and maximum gross weights for vehicles and loads moved under permit |
| 511.18(321,321E)     | Movement of vehicles with divisible loads exceeding statutory size or weight limits      |
| 511.19(321E)         | Towing units   |
| 511.20(321E)         | Escorting  |
| 511.21(321,321E)     | Permit violations  |
| 511.22(321)          | Movement of combination vehicles on economic export corridors                            |

## CHAPTERS 512 to 523

Reserved

## CHAPTER 524

## FOR-HIRE INTRASTATE MOTOR CARRIER AUTHORITY

|             |  |
|-------------|--|
| 524.1(325A) | Purpose and applicability  |
| 524.2(325A) | General information  |
| 524.3(325A) | Applications and supporting documents                            |
| 524.4(325A) | Issuance of motor carrier permit or motor carrier certificate    |
| 524.5(325A) | Duplicate motor carrier permit or motor carrier certificate      |
| 524.6(325A) | Amendment to a motor carrier permit or motor carrier certificate |
| 524.7(325A) | Insurance—suspension   |
| 524.8(325A) | Self-insurance for motor carriers of passengers                  |
| 524.9(325A) | Safety self-certification  |

|                   |   |
|-------------------|---|
| 524.10(325A)      | Financial statement                     |
| 524.11(325A)      | Safety education seminar                |
| 524.12 and 524.13 | Reserved                                |
| 524.14(325A)      | Lease of a vehicle                      |
| 524.15(325A)      | Tariffs                                 |
| 524.16            | Reserved                                |
| 524.17(325A)      | Suspension, revocation or reinstatement |
| 524.18(325A)      | Hearings                                |

#### CHAPTERS 525 to 528

Reserved

#### CHAPTER 529

##### FOR-HIRE INTERSTATE MOTOR CARRIER AUTHORITY

|             |  |
|-------------|--|
| 529.1(327B) | Motor carrier regulations                |
| 529.2(327B) | Registering interstate authority in Iowa |
| 529.3(327B) | Waiver of rules                          |

#### CHAPTERS 530 to 539

Reserved

#### CHAPTER 540

##### TRANSPORTATION NETWORK COMPANIES

|              |  |
|--------------|--|
| 540.1(321N)  | Purpose and applicability  |
| 540.2(321N)  | Definitions  |
| 540.3(321N)  | General information  |
| 540.4(321N)  | Application for transportation network company permit and supporting documents |
| 540.5(321N)  | Issuance of permit   |
| 540.6(321N)  | Amendment to transportation network company permit                             |
| 540.7(321N)  | Suspension   |
| 540.8(321N)  | Revocation   |
| 540.9(321N)  | Appeal   |
| 540.10(321N) | Renewal  |
| 540.11(321N) | Record review  |

#### CHAPTERS 541 to 599

Reserved

#### *DRIVER LICENSES*

#### CHAPTER 600

##### GENERAL INFORMATION

|            |                          |
|------------|--------------------------|
| 600.1(321) | Definitions              |
| 600.2(17A) | Information and location |
| 600.3(321) | Seat belt exemptions     |

#### CHAPTER 601

##### APPLICATION FOR LICENSE

|            |  |
|------------|--|
| 601.1(321) | Application for license                                    |
| 601.2(321) | Surrender of license and nonoperator's identification card |
| 601.3(321) | Emergency contact information                              |
| 601.4      | Reserved   |
| 601.5(321) | Proofs submitted with application                          |
| 601.6(321) | Parent's, guardian's or custodian's consent                |
| 601.7(321) | REAL ID driver's license                                   |

#### CHAPTER 602

##### CLASSES OF DRIVER'S LICENSES

|                 |  |
|-----------------|--|
| 602.1(321)      | Driver's licenses                      |
| 602.2(321)      | Information and forms                  |
| 602.3           | Reserved                               |
| 602.4(321)      | Definitions of immediate family        |
| 602.5 to 602.10 | Reserved                               |
| 602.11(321)     | Class C noncommercial driver's license |

|                  |   |
|------------------|---|
| 602.12(321)      | Class D noncommercial driver's license (chauffeur)  |
| 602.13(321)      | Class M noncommercial driver's license (motorcycle) |
| 602.14(321)      | Transition from five-year to eight-year licenses    |
| 602.15 to 602.17 | Reserved  |
| 602.18(321)      | Motorcycle instruction permit                       |
| 602.19(321)      | Noncommercial instruction permit                    |
| 602.20           | Reserved  |
| 602.21(321)      | Special noncommercial instruction permit            |
| 602.22           | Reserved  |
| 602.23(321)      | Chauffeur's instruction permit                      |
| 602.24(321)      | Motorized bicycle license                           |
| 602.25(321)      | Minor's restricted license                          |
| 602.26(321)      | Minor's school license                              |

#### CHAPTER 603

Reserved

#### CHAPTER 604

#### LICENSE EXAMINATION

|                  |   |
|------------------|---|
| 604.1(321)       | Authority and scope   |
| 604.2(321)       | Definitions   |
| 604.3(17A)       | Information and forms   |
| 604.4 to 604.6   | Reserved  |
| 604.7(321)       | Examination   |
| 604.8 and 604.9  | Reserved  |
| 604.10(321)      | Vision screening  |
| 604.11(321)      | Vision standards  |
| 604.12(321)      | Vision referrals  |
| 604.13(321)      | Vision screening results  |
| 604.14 to 604.19 | Reserved  |
| 604.20(321)      | Knowledge test  |
| 604.21(321)      | Knowledge test requirements and waivers                                   |
| 604.22 to 604.29 | Reserved  |
| 604.30(321)      | Driving test  |
| 604.31(321)      | Driving test requirements and waivers for noncommercial driver's licenses |
| 604.32 to 604.34 | Reserved  |
| 604.35(321)      | Determination of gross vehicle weight rating                              |
| 604.36 to 604.39 | Reserved  |
| 604.40(321)      | Failure to pass examination   |
| 604.41 to 604.44 | Reserved  |
| 604.45(321)      | Reinstatement   |
| 604.46 to 604.49 | Reserved  |
| 604.50(321)      | Special reexaminations  |

#### CHAPTER 605

#### LICENSE ISSUANCE

|                   |   |
|-------------------|---|
| 605.1(321)        | Scope                                       |
| 605.2(321)        | Definitions                                 |
| 605.3(321)        | Persons exempt                              |
| 605.4(252J,321)   | Persons not to be licensed                  |
| 605.5(321)        | Contents of license                         |
| 605.6(321)        | License class                               |
| 605.7(321)        | Endorsements                                |
| 605.8(321)        | Restrictions                                |
| 605.9(321)        | License term for temporary foreign national |
| 605.10(321)       | Fees for driver's licenses                  |
| 605.11(321)       | Duplicate license                           |
| 605.12(321)       | Address changes                             |
| 605.13 and 605.14 | Reserved                                    |
| 605.15(321)       | License extension                           |
| 605.16(321)       | Military extension                          |
| 605.17 to 605.19  | Reserved                                    |

|                  |                                      |
|------------------|--------------------------------------|
| 605.20(321)      | Fee adjustment for upgrading license |
| 605.21 to 605.24 | Reserved                             |
| 605.25(321)      | License renewal                      |
| 605.26(321)      | Graduated driver's license upgrades  |

#### CHAPTER 606

Reserved

#### CHAPTER 607

### COMMERCIAL DRIVER LICENSING

|                   |  |
|-------------------|--|
| 607.1(321)        | Scope  |
| 607.2(17A)        | Information  |
| 607.3(321)        | Definitions  |
| 607.4 and 607.5   | Reserved   |
| 607.6(321)        | Exemptions   |
| 607.7(321)        | Records  |
| 607.8 and 607.9   | Reserved   |
| 607.10(321)       | Adoption of federal regulations  |
| 607.11 to 607.14  | Reserved   |
| 607.15(321)       | Application  |
| 607.16(321)       | Commercial driver's license (CDL)  |
| 607.17(321)       | Endorsements   |
| 607.18(321)       | Restrictions   |
| 607.19            | Reserved   |
| 607.20(321)       | Commercial learner's permit  |
| 607.21 to 607.24  | Reserved   |
| 607.25(321)       | Examination for a commercial driver's license  |
| 607.26(321)       | Vision screening   |
| 607.27(321)       | Knowledge tests  |
| 607.28(321)       | Skills test  |
| 607.29            | Reserved   |
| 607.30(321)       | Third-party testing  |
| 607.31(321)       | Test results   |
| 607.32(321)       | Knowledge and skills testing of nondomiciled military personnel                        |
| 607.33 and 607.34 | Reserved   |
| 607.35(321)       | Issuance of commercial driver's license and commercial learner's permit                |
| 607.36            | Reserved   |
| 607.37(321)       | Commercial driver's license renewal  |
| 607.38(321)       | Transfers from another state   |
| 607.39(321)       | Disqualification   |
| 607.40(321)       | Sanctions  |
| 607.41 to 607.44  | Reserved   |
| 607.45(321)       | Reinstatement  |
| 607.46 to 607.48  | Reserved   |
| 607.49(321)       | Restricted commercial driver's license   |
| 607.50(321)       | Self-certification of type of driving and submission of medical examiner's certificate |
| 607.51(321)       | National drug and alcohol clearinghouse  |
| 607.52(321)       | Determination of gross vehicle weight rating   |

#### CHAPTERS 608 to 614

Reserved

#### CHAPTER 615

### SANCTIONS

|                 |                         |
|-----------------|-------------------------|
| 615.1(321)      | Definitions             |
| 615.2(321)      | Scope                   |
| 615.3(17A)      | Information and address |
| 615.4(321)      | Denial for incapability |
| 615.5 and 615.6 | Reserved                |
| 615.7(321)      | Cancellations           |
| 615.8           | Reserved                |
| 615.9(321)      | Habitual offender       |
| 615.10          | Reserved                |

|                   |   |
|-------------------|---|
| 615.11(321)       | Periods of suspension or revocation                                       |
| 615.12(321)       | Suspension of a habitually reckless or negligent driver                   |
| 615.13(321)       | Suspension of a habitual violator   |
| 615.14(321)       | Suspension for incapability   |
| 615.15(321)       | Suspension for unlawful use of a license                                  |
| 615.16(321)       | Suspension for out-of-state offense                                       |
| 615.17(321)       | Suspension for a serious violation  |
| 615.18(321)       | Suspension under the nonresident violator compact                         |
| 615.19(321)       | Suspension for a charge of vehicular homicide                             |
| 615.20(321)       | Suspension for moving violation during driving probation                  |
| 615.21(321)       | Suspension of a minor's school license and minor's restricted license     |
| 615.22(321)       | Suspension for nonpayment of fine, penalty, surcharge or court costs      |
| 615.23(321)       | Suspensions for juveniles   |
| 615.24(252J)      | Suspension upon receipt of a certificate of noncompliance                 |
| 615.25            | Reserved  |
| 615.26(321)       | Suspension for violation of a license restriction                         |
| 615.27 and 615.28 | Reserved  |
| 615.29(321)       | Mandatory revocation  |
| 615.30(321)       | Revocation for out-of-state offense                                       |
| 615.31            | Reserved  |
| 615.32(321)       | Extension of suspension or revocation period under Iowa Code chapter 321J |
| 615.33(321)       | Revocation of a minor's license   |
| 615.34 and 615.35 | Reserved  |
| 615.36(321)       | Effective date of suspension, revocation, disqualification or bar         |
| 615.37(321)       | Service of notice   |
| 615.38(17A,321)   | Hearing and appeal process  |
| 615.39(321)       | Surrender of license  |
| 615.40(321)       | License reinstatement or reissue  |
| 615.41(321)       | Investigation of convictions based on fraud                               |
| 615.42(321)       | Remedial driver improvement action under Iowa Code section 321.180B       |
| 615.43(321)       | Driver improvement program  |
| 615.44            | Reserved  |
| 615.45(321)       | Temporary restricted license (work permit)                                |

## CHAPTERS 616 to 619

Reserved

## CHAPTER 620

## OWI AND IMPLIED CONSENT

|                  |  |
|------------------|--|
| 620.1            | Reserved   |
| 620.2(321J)      | Information and location   |
| 620.3(321J)      | Issuance of temporary restricted license                                     |
| 620.4(321J)      | Hearings and appeals   |
| 620.5(321J)      | Reinstatement  |
| 620.6(321J)      | Issuance of temporary restricted license after revocation period has expired |
| 620.7 to 620.9   | Reserved   |
| 620.10(321J)     | Revocation for deferred judgment   |
| 620.11 to 620.14 | Reserved   |
| 620.15(321J)     | Substance abuse evaluation and treatment or rehabilitation services          |
| 620.16(321J)     | Drinking drivers course  |

## CHAPTERS 621 to 624

Reserved

## CHAPTER 625

DRIVER'S LICENSES FOR UNDERCOVER  
LAW ENFORCEMENT OFFICERS

|            |              |
|------------|--------------|
| 625.1(321) | Purpose      |
| 625.2(321) | Application  |
| 625.3(321) | Issuance     |
| 625.4      | Reserved     |
| 625.5(321) | Cancellation |

625.6(321) Records

CHAPTERS 626 to 629

Reserved

CHAPTER 630

NONOPERATOR'S IDENTIFICATION

630.1(321) General information  
 630.2(321) Application and issuance  
 630.3(321) Duplicate card  
 630.4(321) Cancellation

CHAPTERS 631 to 633

Reserved

CHAPTER 634

DRIVER EDUCATION

634.1(321) Information and location  
 634.2(321) Definitions  
 634.3 Reserved  
 634.4(321) Driver education course standards and requirements  
 634.5 Reserved  
 634.6(321) Instructor qualifications, application and certification  
 634.7(321) Instructor disqualification, investigation and cancellation  
 634.8(321) Private and commercial driver education schools  
 634.9 and 634.10 Reserved  
 634.11(321) Driver education—teaching parent

CHAPTER 635

MOTORCYCLE RIDER EDUCATION (MRE)

635.1(321) Definitions  
 635.2(321) Approved course in motorcycle rider education  
 635.3(321) Instructors  
 635.4(321) Responsibilities of sponsors  
 635.5(321) Use of motorcycle rider education fund  
 635.6(321) Information and location  
 635.7(321) License issuance

CHAPTER 636

MOTORIZED BICYCLE RIDER EDUCATION

636.1(321) Information and location  
 636.2(321) Definitions  
 636.3 Reserved  
 636.4(321) Approved program in motorized bicycle rider education  
 636.5(321) Course requirements  
 636.6(321) Instructor approval  
 636.7(321) Evaluation

CHAPTERS 637 to 639

Reserved

CHAPTER 640

FINANCIAL RESPONSIBILITY

640.1(321A) General provisions  
 640.2(321A) Hearing and appeal process  
 640.3(321A) Accident reporting requirements  
 640.4(321A) Security required following accident  
 640.5(321A) Judgments  
 640.6(321A) Proof of financial responsibility  
 640.7(321A) Transfer of suspended registration

CHAPTER 641

FINANCIAL LIABILITY COVERAGE CARDS

|            |   |
|------------|---|
| 641.1(321) | Purpose and applicability                               |
| 641.2(321) | Definitions   |
| 641.3(321) | Content of financial liability coverage card            |
| 641.4(321) | Responsibilities of insurer                             |
| 641.5(321) | Acquisition of additional or replacement motor vehicles |
| 641.6(321) | New policies  |

#### CHAPTERS 642 to 699

Reserved

#### *AERONAUTICS*

#### CHAPTER 700

#### AERONAUTICS ADMINISTRATION

|            |                            |
|------------|----------------------------|
| 700.1(328) | Definitions                |
| 700.2(17A) | Information and forms      |
| 700.3(17A) | Hearing and appeal process |

#### CHAPTERS 701 to 709

Reserved

#### CHAPTER 710

#### AIRPORT IMPROVEMENT PROGRAM

|            |                                   |
|------------|-----------------------------------|
| 710.1(328) | Purpose                           |
| 710.2(328) | Definitions                       |
| 710.3(17A) | Information and forms             |
| 710.4(330) | Federal airport improvement funds |
| 710.5(328) | State airport improvement funds   |

#### CHAPTERS 711 to 714

Reserved

#### CHAPTER 715

#### AIR SERVICE DEVELOPMENT PROGRAM

|            |                             |
|------------|-----------------------------|
| 715.1(328) | Purpose                     |
| 715.2(328) | Definitions                 |
| 715.3(328) | Eligibility and funding     |
| 715.4(328) | Eligible project activities |
| 715.5      | Reserved                    |
| 715.6(328) | Project selection criteria  |
| 715.7(328) | Application                 |
| 715.8(328) | Project administration      |

#### CHAPTER 716

#### COMMERCIAL SERVICE VERTICAL INFRASTRUCTURE PROGRAM

|            |                                |
|------------|--------------------------------|
| 716.1(328) | Purpose                        |
| 716.2(328) | Definitions                    |
| 716.3(328) | Information and forms          |
| 716.4(328) | Eligible airports              |
| 716.5(328) | Eligible project activities    |
| 716.6      | Reserved                       |
| 716.7(328) | Project application and review |
| 716.8(328) | Project administration         |

#### CHAPTER 717

#### GENERAL AVIATION VERTICAL INFRASTRUCTURE PROGRAM

|            |                             |
|------------|-----------------------------|
| 717.1(328) | Purpose                     |
| 717.2(328) | Definitions                 |
| 717.3(328) | Information and forms       |
| 717.4(328) | Applicant eligibility       |
| 717.5(328) | Eligible project activities |
| 717.6      | Reserved                    |
| 717.7(328) | Funding                     |
| 717.8(328) | Project priorities          |

|             |                        |
|-------------|------------------------|
| 717.9(328)  | Project applications   |
| 717.10(328) | Review and approval    |
| 717.11(328) | Project administration |

## CHAPTERS 718 and 719

Reserved

## CHAPTER 720

## IOWA AIRPORT REGISTRATION

|                  |                          |
|------------------|--------------------------|
| 720.1(328)       | Scope                    |
| 720.2(328)       | Definitions              |
| 720.3(328)       | Contact information      |
| 720.4(328)       | Public-use airport       |
| 720.5            | Reserved                 |
| 720.6(328)       | Revocation or denial     |
| 720.7 to 720.9   | Reserved                 |
| 720.10(328)      | Minimum safety standards |
| 720.11 to 720.14 | Reserved                 |
| 720.15(328)      | Airport closing          |

## CHAPTERS 721 to 749

Reserved

## CHAPTER 750

## AIRCRAFT REGISTRATION

|                  |                                     |
|------------------|-------------------------------------|
| 750.1(328)       | Purpose                             |
| 750.2(328)       | Definitions                         |
| 750.3(17A)       | Information and forms               |
| 750.4 to 750.8   | Reserved                            |
| 750.9(328)       | Registration                        |
| 750.10(328)      | First registration procedure        |
| 750.11 to 750.14 | Reserved                            |
| 750.15(328)      | Aircraft not airworthy              |
| 750.16 to 750.19 | Reserved                            |
| 750.20(328)      | Renewal notice                      |
| 750.21 to 750.28 | Reserved                            |
| 750.29(328)      | Penalty on registration fees        |
| 750.30(328)      | Application for special certificate |
| 750.31(328)      | Lien                                |

## CHAPTERS 751 to 799

Reserved

*RAILROADS*

## CHAPTER 800

## ITEMS OF GENERAL APPLICATION FOR RAILROADS

|                  |                                      |
|------------------|--------------------------------------|
| 800.1(307)       | Definitions                          |
| 800.2(17A)       | Location and submission of documents |
| 800.3(327C)      | Accounts                             |
| 800.4(327C)      | Annual reports                       |
| 800.5 to 800.14  | Reserved                             |
| 800.15(327F)     | Train speed ordinances               |
| 800.16 to 800.19 | Reserved                             |
| 800.20(327G)     | Removal of tracks from crossings     |
| 800.21(327G)     | Federal citations                    |

## CHAPTER 801

Reserved

## CHAPTER 802

## NOTIFICATION OF RAILROAD ACCIDENTS/INCIDENTS

|             |  |
|-------------|--|
| 802.1(327C) | Written reports                              |
| 802.2(327C) | Notification of railroad accidents/incidents |

## CHAPTERS 803 to 809

Reserved

## CHAPTER 810

## RAILROAD SAFETY STANDARDS

|             |  |
|-------------|--|
| 810.1(327C) | Track safety standards                                 |
| 810.2(327C) | Track inspection                                       |
| 810.3       | Reserved   |
| 810.4(327F) | First aid and medical treatment for railroad employees |
| 810.5(327F) | Worker transportation motor vehicle equipment          |
| 810.6(327F) | Worker transportation rest periods                     |

## CHAPTER 811

## HIGHWAY-RAILROAD GRADE CROSSING WARNING DEVICES

|            |                     |
|------------|---------------------|
| 811.1(307) | Standards           |
| 811.2(307) | Contact information |

## CHAPTER 812

CLASSIFICATIONS AND STANDARDS FOR  
HIGHWAY-RAILROAD GRADE CROSSINGS

|            |   |
|------------|---|
| 812.1(307) | Purpose and contact information                   |
| 812.2(307) | Classification                                    |
| 812.3(307) | Warning device standards and their implementation |
| 812.4(307) | Effect of rules                                   |

## CHAPTER 813

## CLOSE-CLEARANCE WARNING SIGNS ALONG RAILROAD TRACKS

|                 |                            |
|-----------------|----------------------------|
| 813.1(327F)     | Purpose and scope          |
| 813.2(327F)     | Applicability              |
| 813.3(327F)     | Information                |
| 813.4(327F)     | Definitions                |
| 813.5(327F)     | Close-clearance dimensions |
| 813.6(327F)     | Signing requirements       |
| 813.7 and 813.8 | Reserved                   |
| 813.9(327F)     | Enforcement                |
| 813.10(327F)    | Reimbursement              |

## CHAPTERS 814 to 819

Reserved

## CHAPTER 820

## HIGHWAY GRADE CROSSING SAFETY FUND

|             |  |
|-------------|--|
| 820.1(327G) | Definitions  |
| 820.2(327G) | Purpose  |
| 820.3(327G) | Information and submissions  |
| 820.4(327G) | Participation in the maintenance costs of eligible warning devices |
| 820.5(327G) | Reimbursement  |

## CHAPTER 821

HIGHWAY-RAILROAD GRADE CROSSING SURFACE  
REPAIR FUND

|             |   |
|-------------|---|
| 821.1(327G) | Definitions   |
| 821.2(327G) | General information   |
| 821.3(327G) | Procedures for the use of grade crossing surface repair funds |

## CHAPTER 822

## RAILROAD REVOLVING LOAN AND GRANT FUND PROGRAM

|             |                          |
|-------------|--------------------------|
| 822.1(327H) | Introduction and purpose |
| 822.2(327H) | Definitions              |
| 822.3(327H) | Information              |
| 822.4       | Reserved                 |
| 822.5(327H) | Funding                  |

|              |                                       |
|--------------|---------------------------------------|
| 822.6        | Reserved                              |
| 822.7(327H)  | Applicant eligibility                 |
| 822.8(327H)  | Eligible and ineligible project costs |
| 822.9        | Reserved                              |
| 822.10(327H) | Project application                   |
| 822.11(327H) | Project evaluation and approval       |
| 822.12(327H) | Award acceptance                      |
| 822.13(327H) | Project agreement and administration  |

#### CHAPTERS 823 to 899

Reserved

#### *PUBLIC TRANSIT*

#### CHAPTERS 900 to 909

Reserved

#### CHAPTER 910

#### COORDINATION OF PUBLIC TRANSIT SERVICES

|             |  |
|-------------|--|
| 910.1(324A) | Definitions  |
| 910.2(17A)  | Information and location                               |
| 910.3(324A) | Statewide transportation coordination advisory council |
| 910.4(324A) | Certification process                                  |
| 910.5(324A) | Standards for compliance                               |
| 910.6(324A) | Noncompliance  |
| 910.7(324A) | Noncompliant sanctions                                 |
| 910.8(324A) | Revocation   |

#### CHAPTER 911

#### SCHOOL TRANSPORTATION SERVICES PROVIDED BY REGIONAL TRANSIT SYSTEMS

|                 |  |
|-----------------|--|
| 911.1(321)      | Purpose and information                            |
| 911.2(321,324A) | Definitions  |
| 911.3(321)      | Services to students as part of the general public |
| 911.4(321)      | Contracts for nonexclusive school transportation   |
| 911.5(321)      | Adoption of federal regulations                    |
| 911.6(321)      | Driver standards                                   |
| 911.7(321)      | Vehicle standards                                  |
| 911.8(321)      | Maintenance  |
| 911.9(321)      | Safety equipment                                   |
| 911.10(321)     | Operating policies                                 |

#### CHAPTERS 912 to 919

Reserved

#### CHAPTER 920

#### STATE TRANSIT ASSISTANCE

|             |                        |
|-------------|------------------------|
| 920.1(324A) | Statement of policy    |
| 920.2(324A) | General information    |
| 920.3(324A) | Definitions            |
| 920.4(324A) | Types of projects      |
| 920.5(324A) | Standards for projects |
| 920.6(324A) | Processing             |

#### CHAPTER 921

#### ADVANCED ALLOCATIONS OF STATE TRANSIT ASSISTANCE FUNDING

|             |   |
|-------------|---|
| 921.1(324A) | Scope of chapter  |
| 921.2(324A) | Advance allocations   |
| 921.3(324A) | Application for advance allocations   |
| 921.4(324A) | Application approval  |
| 921.5(324A) | Consideration in determining the approval of advance allocation application |
| 921.6       | Reserved  |
| 921.7(324A) | Reports, and suspension and termination of allocations                      |

- 921.8(324A) Income derived from interest-bearing accounts and investments
- 921.9(324A) Joint participation agreement close and audits

CHAPTER 922  
FEDERAL TRANSIT ASSISTANCE

- 922.1(324A) Projects for nonurbanized areas and private nonprofit transportation providers

CHAPTER 923  
CAPITAL MATCH REVOLVING LOAN FUND

- 923.1(71GA,ch265) General information
- 923.2(71GA,ch265) Definitions
- 923.3(71GA,ch265) System eligibility
- 923.4(71GA,ch265) Project eligibility
- 923.5(71GA,ch265) Procedure

CHAPTER 924  
PUBLIC TRANSIT INFRASTRUCTURE GRANT PROGRAM

- 924.1(324A) Purpose
- 924.2(324A) Definitions
- 924.3(324A) Information and forms
- 924.4 and 924.5 Reserved
- 924.6(324A) Project eligibility
- 924.7(324A) Eligible project activities
- 924.8(324A) Ineligible project activities
- 924.9 Reserved
- 924.10(324A) Funding
- 924.11(324A) Project applications
- 924.12 and 924.13 Reserved
- 924.14(324A) Project priorities
- 924.15(324A) Review and approval
- 924.16(324A) Project agreement, administration and ownership



*GENERAL*

CHAPTER 1

ORGANIZATION OF THE DEPARTMENT OF TRANSPORTATION

[Prior to 6/3/87, Transportation Department[820]—(01,A)Ch1]

Rescinded **ARC 8242C**, IAB 10/2/24, effective 11/6/24

CHAPTER 2

PROVISIONS APPLICABLE TO ALL RULES

Rescinded **ARC 8242C**, IAB 10/2/24, effective 11/6/24

CHAPTER 3

Reserved



CHAPTER 4  
PUBLIC RECORDS AND FAIR INFORMATION PRACTICES

**761—4.1(22,305) General provisions.**

**4.1(1) Scope of chapter.**

a. This chapter describes the provisions governing public access to records that are owned by or in the physical possession of the department. However, access to personnel and payroll records may also be subject to the rules of the department of administrative services.

b. This chapter does not affect the policy of the department to respond, without charge, to routine oral or written inquiries that do not involve the furnishing of records.

c. This chapter does not make available records compiled by the department in reasonable anticipation of court litigation or formal administrative proceedings. The availability of these records to the public or to any individual or party to such litigation or proceedings shall be governed by applicable legal and constitutional principles, statutes, rules of discovery, evidentiary privileges, and applicable regulations of the department.

**4.1(2) Custodian.** The custodian of a record is the person who heads the departmental office responsible for that record. The department's electronic Records Management Manual identifies the offices that are responsible for particular records.

a. As used in this chapter, the term "custodian" includes the custodian's superiors and the custodian's designees.

b. A custodian's designee may include but is not limited to the records center.

c. The custodian of a record is authorized to provide or deny access to that record in accordance with the provisions of this chapter. However, the custodian's authority to provide access to a confidential record is limited to the persons listed in subrule 4.4(2).

**4.1(3) Address of records center.** The address of the department's records center is: Records Management Section, Information Technology Division, Iowa Department of Transportation, 800 Lincoln Way, Ames, Iowa 50010.

**4.1(4) Records Management Manual.**

a. The department's electronic Records Management Manual contains the records management information required by Iowa Code chapter 305, including descriptions of department records and their formats, management, maintenance, storage, retention, security, and disposal.

b. The manual also contains the descriptive information on records that is required by Iowa Code section 22.11. The manual is updated as needed and its provisions are made a part of these rules.

c. The manual is available for examination and copying at the department's records center and at various other departmental offices located throughout the state. A copy of the manual may also be obtained, upon request, from the records center.

**4.1(5) Availability of open records.** Open records of the department are available to the public for examination and copying unless otherwise provided by state or federal law, regulation or rule.

**4.1(6) Data processing matching.** All departmental data processing systems that have common data elements can potentially match, collate and compare personally identifiable information.

**4.1(7) Warranty.** No warranty of the accuracy or completeness of a record is made.

**4.1(8) Existing records.** A request for access shall apply only to records that exist at the time the request is made and access is provided. The department is not required to create, compile or procure a record solely for the purpose of making it available. EXCEPTIONS: See Iowa Code section 22.3A and subrule 4.4(4).

**4.1(9) Definitions.** As used in this chapter:

"*Confidential record*" means a record that is not available as a matter of right for examination and copying by members of the public under applicable provisions of law. Confidential records include records or information contained in records that the department is prohibited by law from making available for examination by members of the public, and records or information contained in records that are specified as confidential by Iowa Code section 22.7 or another provision of law, but that may be disclosed upon order of the court, the custodian of the record, or by another person duly authorized to release the record. Mere inclusion in a record of information declared confidential by an applicable provision of law does not necessarily make that entire record a confidential record.

"*Open record*" means a record other than a confidential record.

"*Personally identifiable information*" means information about an individual in a record that identifies the individual and is retrievable by a unique personal identifier associated with the individual.

"*Public*" means those persons who are not officials, employees or agents of the department.

"*Record*" means the whole or a part of a "public record" as defined in Iowa Code section 22.1 that is owned by or in the physical possession of the department.

"*Requester*" means a member of the public.

This rule is intended to implement Iowa Code chapter 22 and section 305.15.

[ARC 7909B, IAB 7/1/09, effective 7/1/09; ARC 2049C, IAB 7/8/15, effective 8/12/15]

**761—4.2(22) Statement of policy and purpose.** It is the policy of the department that free and open examination of public records is generally in the public interest. The purpose of these rules is to facilitate broad public access to open records and sound determinations with respect to the handling of confidential records.

This rule is intended to implement Iowa Code chapter 22.

**761—4.3(22) Access to records.**

**4.3(1) Submission of request for access.**

*a.* A request for access to a record shall be submitted to the custodian of the record. If the requester does not know the identity of the custodian, the request may be submitted to the records center at the address in subrule 4.1(3). The records center will forward the request to the custodian.

*b.* Notwithstanding paragraph “a” of this subrule, any request that may be related to a potential or an actual tort claim or other litigation shall be submitted to: General Counsel, Iowa Department of Transportation, 800 Lincoln Way, Ames, Iowa 50010. If the custodian receives a request of this nature, the custodian shall forward the request to the department’s general counsel.

*c.* If a request for access is misdirected, department personnel will forward the request to the custodian.

**4.3(2) Office hours.** Open records are available during customary office hours, which are 8 a.m. to 4:30 p.m., excluding Saturdays, Sundays, and legal holidays.

**4.3(3) Form of request.** A request for access to a record shall reasonably describe the record requested. A request for access to an open record may be made in person, in writing, by telephone, or by electronic means. A requester shall not be required to give reasons for requesting an open record.

**4.3(4) Response to request.** The custodian shall provide access to an open record promptly upon request. However, if the size or nature of the request makes prompt access infeasible, the custodian shall fill the request as soon as feasible and give the requester an estimate of when the record will be available.

**4.3(5) Delay.** Access to a record may be delayed for one of the purposes authorized by Iowa Code subsection 22.8(4) or 22.10(4). The custodian shall inform the requester of the reason for the delay and the estimated length of the delay.

**4.3(6) Security of records.** No person may, without permission from the custodian, search agency files or remove any record copy from the place where it is made available. The custodian shall supervise the examination and copying of records and protect the records from damage and disorganization. Original paper records shall be released from department custody only upon court order. The custodian shall place at least one certified copy in the file if the original record is released.

**4.3(7) Copies.** A photocopy of an open record may be made on department photocopiers. If a photocopier is not available in the office where an open record is kept, the custodian shall permit its examination in that office and, if requested, arrange to have a copy made elsewhere. Most department records are stored in electronic formats; therefore, if the requested record is electronic, an electronic copy will be provided. If the requester is unable to open and read an electronic copy, or if the record does not exist in electronic form, a hard copy will be provided.

**4.3(8) Fees.** The department may charge fees for records as authorized by Iowa Code section 22.3 or another provision of law. Under Iowa Code section 22.3, the fee for the copying service, whether electronic or hard copy, shall not exceed the cost of providing the service.

This rule is intended to implement Iowa Code sections 22.2, 22.3, 22.4, 22.8, 22.10, and 22.11.

[ARC 2049C, IAB 7/8/15, effective 8/12/15; ARC 5424C, IAB 2/10/21, effective 3/17/21]

**761—4.4(22) Access to confidential records.** The following provisions are in addition to those specified in rule 761—4.3(22) and are minimum requirements. A statute or another department rule may impose additional requirements for access to certain classes of confidential records. A confidential record may, due to its nature or the way it is compiled or stored, contain a mixture of confidential and nonconfidential information. The department shall not refuse to release the nonconfidential information simply because of the manner in which the record is compiled or stored.

**4.4(1) Procedure.**

*a. Form of request.* The custodian shall ensure that there is sufficient information to provide reasonable assurance that access to a confidential record may be granted. Therefore, the custodian may require the requester to:

- (1) Submit the request in writing.
- (2) Provide proof of identity and authority to secure access to the record.

(3) Sign a certified statement or affidavit listing the specific reasons justifying access to the record and provide any proof necessary to establish relevant facts.

*b. Response to request.* The custodian shall notify the requester of approval or denial of the request for access. If the requester indicates to the custodian that a written notice is desired if the request for access is denied, the custodian shall provide such notice promptly. The notice shall be signed by the custodian and include:

- (1) The name and title or position of the custodian, and
- (2) A brief statement of the grounds for denial, including a citation to the applicable statute or other provision of law.

*c. Reconsideration of denial.* A requester whose request is denied by the custodian may apply to the director of transportation for reconsideration of the request.

**4.4(2) Release of confidential records by the custodian.** The custodian may release a confidential record or a portion of it:

- a.* To the legislative services agency pursuant to Iowa Code section 2A.3.
- b.* To the ombudsman pursuant to Iowa Code section 2C.9.
- c.* To other governmental officials and employees only as needed to discharge their duties.
- d.* To those persons as permitted or required by rule 761—4.9(22).
- e.* To persons authorized by the subject of the record in accordance with rule 761—4.5(22).
- f.* To the public information board pursuant to Iowa Code section 23.6.

**4.4(3) Release of confidential records by the director.** Rescinded IAB 9/11/19, effective 10/16/19.

**4.4(4) Information released.** If a person is provided access to less than an entire record, the department shall take measures to ensure that the person is furnished only the information that is to be released. This may be done by providing to the person either an extraction of the information to be released or a copy of the record from which the information not to be released has been deleted.

This rule is intended to implement Iowa Code section 22.11.

[ARC 2049C, IAB 7/8/15, effective 8/12/15; ARC 3026C, IAB 4/12/17, effective 5/17/17; ARC 4659C, IAB 9/11/19, effective 10/16/19]

**761—4.5(22) Consent to release a confidential record to a third party.** To the extent permitted by law, the subject of a confidential record may consent to its release to a third party. The consent must be in writing and must identify the particular record that may be disclosed and the particular person or class of persons to whom the record may be disclosed. The subject of the record may be required to provide proof of identity. Appearance of counsel before the agency on behalf of a person who is the subject of a confidential record may be deemed to constitute consent for the department to disclose records about that person to the person's counsel.

This rule is intended to implement Iowa Code section 22.11.

**761—4.6(22) Requests for confidential treatment.**

**4.6(1)** A person may request that all or a portion of a record be confidential. The request must be submitted in writing to the custodian and:

- a.* Identify the information for which confidential treatment is sought.
- b.* Cite the legal basis that justifies confidential treatment.
- c.* Demonstrate that disclosure of the information would clearly not be in the public interest.
- d.* Give the reasons why any person or persons would be substantially and irreparably injured by disclosure of the information. The requester may be required to provide any proof necessary to support these reasons.

**4.6(2)** The custodian shall notify the requester in writing of the granting or denial of the request and, if denied, the reasons therefor.

**4.6(3)** If the request is denied, the requester may apply to the director of transportation for reconsideration of the request.

This rule is intended to implement Iowa Code sections 22.8 and 22.11.

[ARC 2049C, IAB 7/8/15, effective 8/12/15]

**761—4.7(22) Procedure by which additions, dissents, or objections may be entered into records.** Except as otherwise provided by law, the person who is the subject of a record may have a written statement of additions, dissents or objections entered into that record. The statement shall be filed with the custodian. The statement must be dated and signed by the person who is the subject of the record and include the person's current address and telephone number. This rule does not authorize the person who is the subject of the record to alter the original record or to expand the official record of any agency proceeding.

This rule is intended to implement Iowa Code section 22.11.

**761—4.8(22) Notice to suppliers of information.** When the department requests a person to supply information about that person, the department shall notify the person of the use that will be made of the information, which persons outside the agency might routinely be provided this information, which parts of the requested information are required and which are optional, and the consequences of a failure to provide the information requested. This notice may be given in these or other rules of the department, on the written form used to collect the information, on a separate fact sheet or letter, in brochures, in formal agreements, in contracts, in handbooks, in manuals, orally, or by other appropriate means.

This rule is intended to implement Iowa Code section 22.11.

**761—4.9(22) Confidential records.** This rule describes the types of departmental information or records that are confidential. This rule is not exhaustive. A citation of the legal authority for confidentiality follows each description. The following records shall be kept confidential. Records are listed by category, according to the legal basis for withholding them from public inspection.

Descriptions:

**4.9(1)** Records which are exempt from disclosure under Iowa Code section 22.7.

**4.9(2)** Records which constitute attorney work product, attorney-client communications, or are otherwise privileged. (Attorney work product is confidential under Iowa Code sections 22.7, 622.10 and 622.11, Iowa R. C. P. 1.503, Fed. R. Civ. P. 26(b)(3), and case law. Attorney-client communications are confidential under Iowa Code sections 622.10 and 622.11, the rules of evidence, the Iowa Rules of Professional Conduct, and case law.)

**4.9(3)** Those portions of the department's staff manuals, instructions or other statements issued by the department which set forth criteria or guidelines to be used by its departmental staff in auditing, making inspections, settling commercial disputes or negotiating commercial arrangements, or in the selection or handling of cases, such as operational tactics or allowable tolerances or criteria for the defense, prosecution or settlement of cases, when the disclosure of such statements would enable law violators to avoid detection, facilitate disregard of requirements imposed by law, or give a clearly improper advantage to persons who are in an adverse position to the department. (Iowa Code sections 17A.2 and 17A.3)

**4.9(4)** The detailed minutes and recordings of closed sessions of the commission. However, if a closed session regards a real estate purchase or sale, the minutes and recording shall be available for public inspection when the transaction discussed is completed. (Iowa Code section 21.5)

**4.9(5)** Vehicle accident reports submitted to the department by drivers and peace officers. (Iowa Code sections 321.266 and 321.271)

*a.* However, access shall be granted to those persons authorized by Iowa Code section 321.271.

*b.* Reserved.

**4.9(6)** Unless otherwise ordered by the court, all information filed with the court for the purpose of securing a warrant for an arrest including, but not limited to, a citation and affidavits, until such time as a peace officer has made the arrest and has made the officer's return on the warrant, or the defendant has made an initial appearance in court. (Iowa Code section 804.29)

*a.* However, the information in the record may be disseminated without court order during the course of official duties to the persons authorized in Iowa Code section 804.29 unless access to such information is expressly denied by court order.

*b.* Reserved.

**4.9(7)** All information filed with the court for the purpose of securing a warrant for a search, including, but not limited to, an application and affidavits, until such time as a peace officer has executed the warrant and has made return thereon. (Iowa Code section 808.13)

*a.* During the period of time that information is confidential, it shall be sealed by the court, and the information contained therein shall not be disseminated to any person other than a peace officer, magistrate or other court employee, in the course of official duties.

*b.* Reserved.

**4.9(8)** Information obtained by the department from the examining of reports, returns or records required to be filed or kept under the provisions of Iowa Code chapter 452A, except where disclosure is authorized by Iowa Code chapter 452A. (Iowa Code section 452A.63)

**4.9(9)** Sealed bids, until the time set for the public opening of bids, whereupon bids are unsealed and no longer confidential. (Iowa Code section 72.3)

**4.9(10)** Those records which, if disclosed, would diminish competition or would give an improper advantage to persons who are in an adverse position to the department. These records shall be kept confidential until the transaction to which they relate is consummated. However, if disclosure would reveal information which would hinder future

competition, the records shall be kept confidential. (Iowa Code sections 17A.2, 17A.3, 22.7 and 313.10, Iowa Code chapter 553, and 761—Chapter 20)

*a.* Examples of records which could, in the proper circumstances, be determined to be within this category include, but are not limited to:

- (1) Detailed estimates of the cost of a proposed contract.
- (2) Economic analyses for determining pavement types.
- (3) Negotiations for a proposed contract.
- (4) Methodology for determining unfair bidding practices or bid rigging.
- (5) Price quotations solicited.
- (6) The value of points assigned to a bid rating formula prior to the time set for public opening of bids.
- (7) Laboratory testing reports of suppliers' products. These may also be trade secrets. The subject of the report

has the right of access to it.

*b.* Reserved.

**4.9(11)** Audit reviews for determining equal employment opportunity contract compliance. (Iowa Code section 22.7 and 5 U.S.C. §552 and 552a)

*a.* The subject of the audit review has the right of access to it.

*b.* Reserved.

**4.9(12)** All financial records and any information contained within them that are made available to the department, unless otherwise expressly permitted to be divulged by federal or state law. (Iowa Code sections 22.7 and 422.20 and 5 U.S.C. §552 and 552a)

**4.9(13)** Personal information in any motor vehicle record, including personal information contained on electronic driver's license or nonoperator's identification card records that is provided by the licensee or card holder to the department for use by law enforcement, first responders, emergency medical service providers, and other medical personnel responding to or assisting with an emergency. (Iowa Code sections 22.7 and 321.11 and 18 U.S.C. §2721 et seq.)

*a.* Information other than personal information contained on electronic driver's license or nonoperator's identification card records that is provided by the licensee or card holder to the department for use by law enforcement, first responders, emergency medical service providers, and other medical personnel responding to or assisting with an emergency may be disclosed only as provided in Iowa Code sections 321.11 and 321.11A, 18 U.S.C. §2721 et seq., and 761—Chapter 301.

*b.* The subject of the personal information has the right of access to the information.

**4.9(14)** A report received by the department from a physician licensed under Iowa Code chapter 148, an advanced registered nurse practitioner licensed under Iowa Code chapter 152 and licensed with the board of nursing, a physician assistant licensed under Iowa Code chapter 148C or an optometrist licensed under Iowa Code chapter 154 regarding a person who has been diagnosed as having a physical or mental condition which would render the person physically or mentally incompetent to operate a motor vehicle in a safe manner. (Iowa Code section 321.186)

**4.9(15)** Privileged and personnel records or information of law enforcement officers and undercover law enforcement officers, as specified in Iowa Code sections 80G.2 and 80G.3, as well as certain records regarding undercover driver's licenses issued to certified peace officers employed by a local authority or by the state or federal law enforcement officers, as specified in 761—Chapter 625. (Iowa Code sections 22.7, 80G.2, 80G.3 and 321.189A)

*a.* The subject of the record and the head of the law enforcement agency employing the subject have the right of access to the record.

*b.* Reserved.

**4.9(16)** Records related to confidential plates issued for government vehicles. (Iowa Code section 321.19)

*a.* The head of the agency to which the vehicle is assigned has the right of access to the record.

*b.* Reserved.

**4.9(17)** Certified transcripts of labor payrolls (also known as certified payroll records) filed by contractors for federal-aid construction contracts, in accordance with the following paragraphs. (Iowa Code section 22.7, 5 U.S.C. §552 and 552a, and 42 U.S.C. §405)

*a.* The social security numbers in a certified payroll record are confidential. The record itself may be confidential if its release would give advantage to competitors and serve no public purpose.

*b.* The prime contractor and subcontractor, if applicable, that filed the record have the right of access to it.

*c.* Certified payroll records shall be released to the U.S. Department of Labor and Federal Highway Administration during investigations.

*d.* The custodian may release a certified payroll record with social security numbers withheld to representatives of the Iowa Labor Management Work Preservation Fund.

e. The custodian may release a certified payroll record with social security numbers withheld to persons outside the department other than the persons listed in paragraphs 4.9(17) “b” to “d” according to the following procedure:

(1) The request for the record must be in writing.

(2) The custodian shall send a copy of the request by registered mail to the prime contractor. If the request is for subcontractor information, the custodian shall send copies of the request to both the subcontractor and prime contractor.

(3) The requested record shall not be released until 14 calendar days have expired from receipt of the request by the contractor(s) to give the contractor(s) an opportunity to seek an injunction.

**4.9(18)** Information concerning an open or pending railroad accident investigation conducted on behalf of or in conjunction with the Federal Railroad Administration or National Transportation Safety Board to the extent necessary to prevent denial of funds, services or essential information from the United States government. (Iowa Code section 22.9)

**4.9(19)** A geographic computer database, except upon terms and conditions acceptable to the department. (Iowa Code section 22.2)

**4.9(20)** Confidential information, as defined in Iowa Code section 86.45, filed with the workers’ compensation commissioner. (Iowa Code section 22.7)

**4.9(21)** An intelligence assessment and intelligence data under Iowa Code chapter 692, except where disclosure is required or authorized by the Iowa Code. (Iowa Code chapter 692 and Iowa Code section 22.7)

**4.9(22)** Information in a record that would permit the commission, subject to Iowa Code chapter 21, to hold a closed session pursuant to Iowa Code section 21.5 in order to avoid public disclosure of that information, until such time as final action is taken on the subject matter of that information or unless otherwise authorized by the Iowa Code. (Iowa Code section 22.7)

**4.9(23)** Rescinded IAB 9/11/19, effective 10/16/19.

**4.9(24)** All other information or records that by law are or may be confidential.

This rule is intended to implement Iowa Code chapters 22, 553 and 692; Iowa Code sections 17A.2, 17A.3, 21.5, 72.3, 80G.2, 80G.3, 313.10, 321.11, 321.11A, 321.19, 321.186, 321.189A, 321.266, 321.271, 422.20, 452A.63, 622.10, 622.11, 804.29 and 808.13; 5 U.S.C. §552 and 552a; 18 U.S.C. §2721 et seq.; and 42 U.S.C. §405.

[ARC 2049C, IAB 7/8/15, effective 8/12/15; ARC 3026C, IAB 4/12/17, effective 5/17/17; ARC 4659C, IAB 9/11/19, effective 10/16/19; ARC 5424C, IAB 2/10/21, effective 3/17/21; ARC 6060C, IAB 12/1/21, effective 1/5/22]

**761—4.10(22) Release of confidential records.** Rescinded IAB 1/8/03, effective 2/12/03.

[Filed 4/27/88, Notice 2/24/88—published 5/18/88, effective 6/22/88]

[Filed 11/3/88, Notice 9/21/88—published 11/30/88, effective 1/4/89]

[Filed 11/1/89, Notice 9/20/89—published 11/29/89, effective 1/3/90]

[Filed 1/15/92, Notice 12/11/91—published 2/5/92, effective 3/11/92]

[Filed 12/12/02, Notice 10/16/02—published 1/8/03, effective 2/12/03]

[Filed Emergency ARC 7909B, IAB 7/1/09, effective 7/1/09]

[Filed ARC 0661C (Notice ARC 0571C, IAB 1/23/13), IAB 4/3/13, effective 5/8/13]

[Filed ARC 2049C (Notice ARC 1974C, IAB 4/29/15), IAB 7/8/15, effective 8/12/15]

[Filed ARC 3026C (Notice ARC 2922C, IAB 2/1/17), IAB 4/12/17, effective 5/17/17]

[Filed ARC 4659C (Notice ARC 4471C, IAB 6/5/19), IAB 9/11/19, effective 10/16/19]

[Filed ARC 5424C (Notice ARC 5246C, IAB 11/4/20), IAB 2/10/21, effective 3/17/21]

[Filed ARC 6060C (Notice ARC 5921C, IAB 9/22/21), IAB 12/1/21, effective 1/5/22]

CHAPTERS 5 to 9  
Reserved



CHAPTER 10  
ADMINISTRATIVE RULES  
[Prior to 6/3/87, Transportation Department[820]—(01.B) Ch1]

**761—10.1(17A) General.**

**10.1(1) Definitions.** The definitions in Iowa Code section 17A.2 and the definition of “small business” in Iowa Code section 17A.4A are hereby adopted. In addition:

“*Commission*” means the Iowa transportation commission.

“*Department*” means the Iowa department of transportation.

“*Director*” means the director of transportation or the director’s designee.

**10.1(2) Address.** The mailing address of the department’s rules administrator is: Rules Administrator, Government and Community Relations, Iowa Department of Transportation, 800 Lincoln Way, Ames, Iowa 50010. The email address of the rules administrator may be found on the department’s website at [iowadot.gov/administrativerules](http://iowadot.gov/administrativerules).

[ARC 2231C, IAB 11/11/15, effective 12/16/15; ARC 2889C, IAB 1/4/17, effective 2/8/17; ARC 4492C, IAB 6/5/19, effective 7/10/19; Editorial change: IAC Supplement 7/28/21]

**761—10.2(17A) Rule making.**

**10.2(1) Notice of Intended Action—approval and content.** Written authorization to publish proposed rules under Notice of Intended Action in the Iowa Administrative Bulletin shall be made by the director. Each commissioner shall be sent a copy of the Notice of Intended Action before its publication in the Iowa Administrative Bulletin. The Notice of Intended Action shall contain:

a. A copy of the complete text of the proposed rules and a brief explanation of the purpose of the proposed rules.

b. The specific legal authority for the proposed rules.

c. The methods that persons and agencies may use to present their views on the proposed rules. In addition to providing for the submission of written comments, the Notice shall afford any interested person or agency the opportunity to make an oral presentation.

d. Any other information required by statute or rule.

**10.2(2) Notice of Intended Action—submission of written comments and written requests to make an oral presentation.**

a. With regard to proposed rules published under Notice of Intended Action, the department shall accept and consider, from any person or agency, written comments and written requests to make an oral presentation when prepared and submitted in conformance with the following:

(1) Comments and requests shall clearly state the name, address and telephone number of the person or agency authoring the comment or request and the number and title of the proposed rule as given in the Notice of Intended Action.

(2) If an oral presentation is requested, the requester is encouraged to set forth the general subject of the presentation.

(3) Comments and requests shall be submitted to the office specified in the Notice of Intended Action. To be considered, they must be received by the office no later than the date specified in the Notice. The date shall be no less than 20 days after publication of the Notice.

b. The receipt and acceptance for consideration of written comments and written requests shall be promptly acknowledged by the department.

(1) Written comments received after the deadline may be accepted by the department although their consideration is not assured.

(2) Written requests to make an oral presentation received after the deadline shall not be accepted.

c. In addition to the formal procedures contained in this rule, the department may solicit viewpoints or advice concerning proposed rules through informal conferences or consultations as the department may deem desirable.

**10.2(3) Adoption and filing of rules.**

a. The director shall adopt proposed rules unless statutes specifically provide for commission adoption. The commission shall approve rules prior to their adoption by the director.

b. Upon adoption of proposed rules by the director or the commission, the director shall file them in accordance with Iowa Code section 17A.5.

**10.2(4) Regulatory analysis.** A request for issuance of a regulatory analysis shall be submitted to the department’s rules administrator at the address in subrule 10.1(2).

**10.2(5) Concise statement.** If requested in accordance with this subrule, the department shall issue a concise statement of the principal reasons for and against a rule that has been adopted, incorporating therein the reasons for overruling considerations urged against the rule.

a. The request shall:

(1) Clearly state the name, address and telephone number of the person or agency authoring the request and the number and title of the rule which is the subject of the request.

(2) Be submitted in writing to the department’s rules administrator.

(3) Be delivered to the administrator or postmarked no later than the thirtieth calendar day following adoption of the subject rule.

b. A requested concise statement shall be issued either at the time of rule adoption or within 35 days after the department’s rules administrator receives the request.

**10.2(6) Registration.**

a. *Trade or occupational associations.* The state office of a trade or occupational association may register its name and address with the department to receive copies of Notices of Intended Action.

(1) The request must be in writing and indicate the subject matter and the number of copies of Notice of Intended Action it wishes to receive.

(2) The trade or occupational association shall reimburse the department for the actual costs incurred in providing copies to it.

b. *Small businesses.* A small business or an organization of small businesses may register its name and address with the department to receive notification of Notices of Intended Action and of rules adopted and filed without a Notice of Intended Action which may have an impact on small business.

(1) The request must be in writing and may indicate the subject matter of rules it is interested in. An organization requesting registration shall indicate how many small businesses it represents.

(2) At the discretion of the department, notification shall consist of either a copy of the rules or a summary of the subjects and issues involved.

c. *Submission and acknowledgment of requests.* Requests for registration under this subrule shall be submitted to the department’s rules administrator. The receipt of requests for registration shall be promptly acknowledged by the department. The acknowledgment shall either:

(1) Inform the requester that it is registered, or

(2) State that the request is incomplete and indicate the additional information required.

[ARC 2231C, IAB 11/11/15, effective 12/16/15; ARC 4492C, IAB 6/5/19, effective 7/10/19]

**761—10.3(17A) Petitions for rule making.**

**10.3(1)** The department shall accept and consider, from any person or agency, petitions for rule making when submitted to the department’s rules administrator by mail or email and prepared in conformance with the following:

a. Format:

IOWA DEPARTMENT OF TRANSPORTATION

800 Lincoln Way, Ames, Iowa 50010

PETITION BY (insert petitioner’s name)  
FOR THE (insert one: adoption,  
amendment or repeal)  
OF (insert current rule number, if  
applicable, and brief description  
of subject matter)



DOCKET NO. \_\_\_\_\_

PETITION FOR RULE MAKING

(In separate numbered paragraphs, the petition shall include the following.)

1. The petitioner’s name, address and telephone number.

2. The nature of the petitioner’s interest in the matter.

3. The text or the essential terms and conditions of a proposed new rule, or the rule number and text of a rule proposed for amendment or a repeal. In addition, proposed amendments shall be illustrated to portray the changes in wording requested: Deletions are to be indicated by strike-throughs, and additions by underscoring.

4. The reasons for seeking the requested action, including any facts, views, data or arguments relevant to the request. Copies of statutes, rules or other supporting documents referenced in the petition shall be submitted as appendices to the petition or made available to the department upon request.

\*5. If desired, a request to meet informally with the department to discuss the petition.

---

(Signature of petitioner)

*b.* A petition for amendment or repeal of a rule shall pertain to a rule currently in effect at the time the petition is received by the department.

*c.* Petitions should be typewritten, although petitions legibly hand-printed in ink shall be accepted.

**10.3(2)** The date of receipt of a petition is the day it reaches the department's rules administrator. The administrator shall promptly notify the petitioner of the date of receipt and the assigned docket number.

**10.3(3)** If requested in the petition, the department shall schedule an informal meeting with the petitioner to discuss the petition.

**10.3(4)** The department shall notify the petitioner of the director's or commission's determination to grant or deny the petition. If the petition is denied, the notification shall include the reasons for denial.

[ARC 2231C, IAB 11/11/15, effective 12/16/15; ARC 4492C, IAB 6/5/19, effective 7/10/19]

These rules are intended to implement Iowa Code sections 17A.1 to 17A.9, 17A.19, 307.12 and 307A.2.

[Filed 5/22/75]

[Filed 4/7/78, Notice 2/22/78—published 6/7/78, effective 6/7/78]

[Filed 10/3/80, Notice 8/20/80—published 10/29/80, effective 12/3/80]

[Filed without Notice 12/17/80—published 1/7/81, effective 2/11/81]

[Filed 3/8/85, Notice 1/16/85—published 3/27/85, effective 5/1/85]

[Filed 11/7/86, Notice 9/24/86—published 12/3/86, effective 1/7/87]

[Filed 5/11/87, Notice 3/11/87—published 6/3/87, effective 7/8/87]

[Filed 7/5/90, Notice 4/4/90—published 7/25/90, effective 8/29/90]<sup>1</sup>

[Filed 1/15/92, Notice 12/11/91—published 2/5/92, effective 3/11/92]

[Filed 8/26/92, Notice 7/22/92—published 9/16/92, effective 10/21/92]

[Filed 5/18/94, Notice 4/13/94—published 6/8/94, effective 7/13/94]

[Filed 4/8/99, Notice 2/10/99—published 5/5/99, effective 7/1/99]

[Filed 3/7/01, Notice 1/10/01—published 4/4/01, effective 5/9/01]

[Filed 10/11/06, Notice 8/30/06—published 11/8/06, effective 12/13/06]

[Filed ARC 2231C (Notice ARC 2117C, IAB 9/2/15), IAB 11/11/15, effective 12/16/15]

[Filed ARC 2889C (Notice ARC 2779C, IAB 10/26/16), IAB 1/4/17, effective 2/8/17]

[Filed ARC 4492C (Notice ARC 4325C, IAB 3/13/19), IAB 6/5/19, effective 7/10/19]

[Editorial change: IAC Supplement 7/28/21]

<sup>1</sup> Effective date of amendments to 761—10.2(17A) and 10.3(17A) delayed until adjournment of the 1991 General Assembly by the Administrative Rules Review Committee at its meeting held August 15, 1990.



CHAPTER 11  
WAIVER OF RULES

**761—11.1(17A) Purpose and scope.**

**11.1(1)** The purpose of this chapter is to establish a general process for granting waivers from the requirements of department rules. A waiver is an agency action which suspends in whole or in part the requirements or provisions of a rule as applied to an identified person on the basis of the particular circumstances of that person.

**11.1(2)** This chapter does not preclude the granting of waivers using another process if a statute or another department rule so provides. If the rule for which a waiver is sought has a specific waiver process of its own, this chapter is applicable only when it is specifically cited.

**11.1(3)** This chapter does not apply to contested case proceedings.

**11.1(4)** This chapter does not apply to rules that merely define the meaning of a statute or other provision of law if the department does not possess the delegated authority to bind the courts to any extent with its definition.

[ARC 5301C, IAB 12/2/20, effective 1/6/21]

**761—11.2(17A) Authority to grant waiver.** The director of transportation may, in response to a written petition submitted in accordance with rule 761—11.5(17A), grant a waiver from the requirements of a rule. The decision to grant a waiver shall be made at the sole discretion of the director and is final agency action.

**761—11.3(17A) Criteria, considerations and limitations.**

**11.3(1)** The director shall not grant a waiver from the requirements of a rule unless the director or the department has jurisdiction over the rule and the waiver is consistent with any applicable statute, constitutional provision, or other provision of law. The director shall not waive any requirement created or duty imposed by statute.

**11.3(2)** The director may grant a waiver from the requirements of a rule if the director finds, based on clear and convincing evidence, all of the following:

- a. Application of the rule will pose an undue hardship.
- b. The waiver will not prejudice the substantial legal rights of any person.
- c. The provisions of the rule subject to waiver are not specifically mandated by statute or another provision of law, and the waiver will not cause a denial of federal funds.
- d. Substantially equal protection of the public health, safety, and welfare will be afforded by means other than that prescribed in the rule.

**11.3(3)** The department shall evaluate each petition for a waiver based on the unique, individual circumstances set out in the petition. The burden of persuasion rests with the petitioner.

**11.3(4)** A waiver, if granted, shall provide the narrowest exception possible to the provisions of the rule.

**11.3(5)** The director may place any condition on a waiver that the director finds desirable to protect the public health, safety, and welfare.

**11.3(6)** A waiver shall not be permanent, unless the director finds that a temporary waiver would be impracticable.

**11.3(7)** If a temporary waiver is granted, there is no automatic right to renewal. At the sole discretion of the director, a waiver may be renewed if the director finds all of the factors set out in subrule 11.3(2) remain valid.

**761—11.4(17A) Decision on waiver.**

**11.4(1)** The director's decision to grant or deny a waiver in response to a written petition shall be in writing and contain:

- a. The name of the person to whom the decision pertains.
- b. A citation to the rule or portion thereof to which the decision pertains and a brief summary of the rule's requirements that are pertinent to the requested waiver.
- c. The relevant facts and reasons upon which the decision is based. If a waiver is granted, the decision must include the findings set out in subrule 11.3(2).
- d. The scope and duration of a waiver if one is granted.
- e. Any other conditions placed on a waiver if one is granted.

**11.4(2)** Reserved.

**761—11.5(17A) Petition for waiver.**

**11.5(1)** *Petitioner.* Any person may petition the department for a waiver from the requirements of a rule. The petitioner must have a real and direct interest in the matter.

**11.5(2) Form of petition.** A petition for a waiver from the requirements of a rule must be in writing and state clearly at the top of the petition that it is a “petition for waiver of a rule.” The petition shall contain the following information where applicable and known to the petitioner:

- a. The name, address and telephone number of the petitioner, and any license, permit or case number applicable to the requested waiver.
- b. A description of and citation to the specific rule from which a waiver is requested.
- c. The specific waiver requested, including its scope and duration.
- d. The relevant facts and reasons the petitioner believes would justify the requested waiver. The petitioner should address each of the following:
  - (1) Why applying the rule will result in an undue hardship to the petitioner.
  - (2) Why waiving the rule will not prejudice the substantial legal rights of any other person.
  - (3) Whether the provisions of the rule are specifically mandated by statute or another law other than the rule.
  - (4) How substantially equal protection of the public health, safety, and welfare will be afforded by means other than those prescribed by the rule.
- e. A history of any prior contacts between the petitioner and the department that are related to the requested waiver.
- f. Whether the petitioner is currently a party to a rule making, declaratory order, contested case, judicial proceeding, or any other proceeding related to the requested waiver.
- g. Information regarding the department’s treatment of similar situations.
- h. The name, address and telephone number of any public agency or political subdivision that also regulates the activity in question or that may be affected if the waiver were granted.
- i. The name, address and telephone number of any person or entity that may be adversely affected if the waiver were granted.
- j. The name, address and telephone number of any person who has knowledge of facts relevant to the requested waiver.
- k. Releases authorizing persons with knowledge of relevant facts to furnish that information to the department.
- l. The signature of the petitioner and the date signed.

**11.5(3) Submission of petition.** A petition for waiver from the requirements of a rule shall be submitted to the rules administrator either by mail to Rules Administrator, Government and Community Relations, Iowa Department of Transportation, 800 Lincoln Way, Ames, Iowa 50010; or by email to the rules administrator’s email address listed on the department’s website at [iowadot.gov/administrativerules](http://iowadot.gov/administrativerules).

[ARC 2231C, IAB 11/11/15, effective 12/16/15; ARC 2889C, IAB 1/4/17, effective 2/8/17; ARC 4492C, IAB 6/5/19, effective 7/10/19; Editorial change: IAC Supplement 7/28/21]

**761—11.6(17A) Action on petition.** Following is the procedure for responding to a petition for a waiver from the requirements of a rule:

- 11.6(1)** The department shall acknowledge receipt of a petition immediately.
- 11.6(2)** Before a waiver is granted or denied, the department may request a petitioner to furnish additional information related to the petition.
- 11.6(3)** The director shall issue a written decision to grant or deny a waiver within 120 days after the department receives the petition unless the petitioner agrees to a later time. However, if the matter is also the subject of a contested case proceeding, the decision to grant or deny a waiver need not be issued until after the final decision in the contested case is issued.
- 11.6(4)** The decision to grant or deny a waiver shall contain the information set out in rule 761—11.4(17A).
- 11.6(5)** Within seven days after the decision is issued, the department shall transmit it to the petitioner.
- 11.6(6)** Failure to grant or deny a waiver within the required time is deemed a denial.
- 11.6(7)** The director’s decision on a petition for a waiver from the requirements of a rule is final agency action.
- 11.6(8)** A petition for a waiver from the requirements of a rule is independent of a contested case proceeding. Submission of a petition does not delay the time to request a contested case hearing, to appeal a proposed decision in a contested case, or to file a petition for judicial review of a final decision in a contested case.
- 11.6(9)** A petition for a waiver from the requirements of a rule is not required to exhaust administrative remedies before judicial review of a department action under Iowa Code section 17A.19.

**761—11.7(17A) Modification or cancellation of waiver.** The department may, after notice and opportunity for hearing, modify or cancel a waiver granted pursuant to this chapter if the director finds any of the following:

1. A material fact upon which the waiver is based is not true or has changed.

2. The petitioner withheld or knowingly misrepresented a material fact relevant to the propriety or desirability of the waiver.
3. The petitioner has failed to comply with the conditions set forth in the decision granting the waiver.
4. The alternate means for ensuring that the public health, safety and welfare will be adequately protected after the waiver is granted are insufficient.

**761—11.8(17A) Records.**

**11.8(1)** All records relating to waivers granted or denied under this chapter are open records. However, if a record contains personal information that is confidential, only the portion of the record that is nonconfidential will be made available for public inspection.

**11.8(2)** The department's rules administrator shall, at a minimum, retain for five years records relating to waivers granted or denied under this chapter.

[ARC 2231C, IAB 11/11/15, effective 12/16/15; ARC 2889C, IAB 1/4/17, effective 2/8/17; ARC 4492C, IAB 6/5/19, effective 7/10/19]

These rules are intended to implement Iowa Code section 17A.9A and Executive Order Number 11, dated September 14, 1999

[Filed 3/7/01, Notice 1/10/01—published 4/4/01, effective 5/9/01]

[Filed 9/14/05, Notice 8/3/05—published 10/12/05, effective 11/16/05]

[Filed 10/11/06, Notice 8/30/06—published 11/8/06, effective 12/13/06]

[Filed ARC 2231C (Notice ARC 2117C, IAB 9/2/15), IAB 11/11/15, effective 12/16/15]

[Filed ARC 2889C (Notice ARC 2779C, IAB 10/26/16), IAB 1/4/17, effective 2/8/17]

[Filed ARC 4492C (Notice ARC 4325C, IAB 3/13/19), IAB 6/5/19, effective 7/10/19]

[Filed ARC 5301C (Notice ARC 5180C, IAB 9/23/20), IAB 12/2/20, effective 1/6/21]

[Editorial change: IAC Supplement 7/28/21]



CHAPTER 12  
DECLARATORY ORDERS  
[Prior to 11/8/06, see rule 761—10.4(17A)]

**761—12.1(17A) Definitions.**

“*Declaratory order*” means the department’s interpretation of a statute, rule or order as applied to specified circumstances. A declaratory order is issued in response to a petition for declaratory order.

“*Director*” means the director of transportation or the director’s designee.

“*Petition for declaratory order*” means a formal request from a person or agency to the department asking how the department will apply a statute, rule or order based on a specific set of facts contained in the petition. The purpose of the petition is to seek binding advice from the department, not to challenge a decision that the department has already made.

**761—12.2(17A) Petition for declaratory order.**

**12.2(1)** Any person or agency may file with the department a petition for declaratory order. The subject matter of the petition must be within the primary jurisdiction of the department.

**12.2(2)** The petition must be submitted to the rules administrator either by mail to Rules Administrator, Government and Community Relations, Iowa Department of Transportation, 800 Lincoln Way, Ames, Iowa 50010; or by email to the rules administrator’s email address listed on the department’s website at [iowadot.gov/administrativerules](http://iowadot.gov/administrativerules).

**12.2(3)** The petition must be typewritten or legibly handwritten in ink and must substantially conform to the following form:

IOWA DEPARTMENT OF TRANSPORTATION  
800 Lincoln Way, Ames, Iowa 50010

---

|   |   |   |
|---|---|---|
| PETITION BY (insert petitioner’s name)<br><br>FOR DECLARATORY ORDER ON<br>(insert number of statute, rule, etc. and brief<br>description of subject matter) | } | DOCKET NO. _____<br><br>PETITION FOR DECLARATORY<br>ORDER |
|---|---|---|

---

(In separate numbered paragraphs, the petition shall include the following.)

1. The petitioner’s name, address and telephone number.
2. The exact words, passages, sentences or paragraphs of statutes, rules, etc. which are the subject of the inquiry.
3. A clear, concise and complete statement of all relevant facts for which the order is requested.
4. The uncertainties or conflicting interpretations which arise when the cited statutes, rules, etc. are applied to the facts.
5. (Optional) The interpretation urged based upon the facts set forth.
6. The reasons for the petition and a full disclosure of the petitioner’s interest.
7. Whether the petitioner is currently a party to a rule-making, contested case or judicial proceeding involving the controversy or uncertainty.
8. The names and addresses, when known, of other persons who may be affected by the declaratory order.

**12.2(4)** The petition must be dated and signed by the petitioner or, if applicable, petitioner’s representative.

**12.2(5)** If applicable, the petition must also include the name, address, and telephone number of the petitioner’s representative and a statement indicating the person to whom communications concerning the petition should be directed.

**12.2(6)** The date of receipt of the petition is the day it reaches the department’s rules administrator. The administrator shall promptly send an acknowledgment of receipt to the petitioner or, if applicable, petitioner’s representative.

[ARC 2231C, IAB 11/11/15, effective 12/16/15; ARC 2889C, IAB 1/4/17, effective 2/8/17; ARC 4492C, IAB 6/5/19, effective 7/10/19; Editorial change: IAC Supplement 7/28/21]

**761—12.3(17A) Notice of petition.** Within 15 days after receipt of a petition for declaratory order, the department shall provide copies of the acknowledgment of receipt and copies of the petition to all persons to whom notice of the petition is required by any provision of law. The department may also give notice to any other persons deemed appropriate.

**761—12.4(17A) Action on petition.**

**12.4(1)** A declaratory order or an order declining to issue a declaratory order shall be issued by the director.

**12.4(2)** The director shall not issue a declaratory order that would substantially prejudice the rights of a person who would be a necessary party and who does not consent in writing to the determination of the matter by a declaratory order proceeding.

**12.4(3)** The director may issue an order declining to issue a declaratory order on some or all of the questions raised in the petition for any of the following reasons:

- a.* The petition does not substantially comply with the required form.
- b.* The petition does not contain facts sufficient to demonstrate that the petitioner will be aggrieved or adversely affected by the failure of the department to issue a declaratory order.
- c.* The department does not have jurisdiction over the questions presented in the petition.
- d.* The questions presented in the petition are also presented in a current rule-making, contested case, or other agency or judicial proceeding that may definitively resolve them.
- e.* The questions presented in the petition would more properly be resolved in a different type of proceeding or by another body with jurisdiction over the matter.
- f.* The questions posed or facts presented in the petition are unclear, vague, incomplete, overbroad, insufficient, or otherwise inappropriate as a basis upon which to issue a declaratory order.
- g.* There is no need to issue a declaratory order because the questions raised in the petition have been settled due to a change in circumstances.
- h.* The petition is not based upon facts calculated to aid in the planning of future conduct but is, instead, based solely upon prior conduct in an effort to establish the effect of that conduct or to challenge a department decision already made.
- i.* The petition requests a declaratory order that would necessarily determine the legal rights, duties or responsibilities of other persons who have not joined in the petition or filed a similar petition and whose position on the questions presented may fairly be presumed to be adverse to that of the petitioner.
- j.* The petitioner requests the department to determine whether a statute is unconstitutional on its face.

**12.4(4)** If the director issues an order declining to issue a declaratory order, the order must indicate the specific grounds for declining to issue a declaratory order and constitutes final agency action on the petition.

**761—12.5(17A) Effect of a declaratory order.** A declaratory order has the same status and binding effect as a final order issued in a contested case proceeding. It is binding on the department and the petitioner and is applicable only in circumstances where the relevant facts and the law involved are indistinguishable from those on which the order was based. As to all other persons, a declaratory order serves only as precedent and is not binding on the department. The issuance of a declaratory order constitutes final agency action on the petition.

These rules are intended to implement Iowa Code sections 17A.9 and 17A.19.

[Filed 10/11/06, Notice 8/30/06—published 11/8/06, effective 12/13/06]

[Filed ARC 2231C (Notice ARC 2117C, IAB 9/2/15), IAB 11/11/15, effective 12/16/15]

[Filed ARC 2889C (Notice ARC 2779C, IAB 10/26/16), IAB 1/4/17, effective 2/8/17]

[Filed ARC 4492C (Notice ARC 4325C, IAB 3/13/19), IAB 6/5/19, effective 7/10/19]

[Editorial change: IAC Supplement 7/28/21]

CHAPTER 13  
CONTESTED CASES

[Prior to 6/3/87, Transportation Department[820]—(01.B) Ch3]

**761—13.1(17A) Definitions.** The definitions in 761—Chapter 2 and in Iowa Code section 17A.2 are hereby adopted.

**761—13.2(17A) Applicability.**

**13.2(1)** This chapter of rules provides the minimum procedural requirements for department involvement in contested cases under Iowa Code chapter 17A.

**13.2(2)** Rules which apply to a particular type of contested case shall take precedence over this chapter of rules. If there are no other rules applicable to a particular type of contested case, it shall be conducted in accordance with this chapter of rules.

**761—13.3(17A) Initiation of contested case.**

**13.3(1)** The department may initiate a contested case proceeding to determine the legal rights, duties or privileges of a person as required by the constitution or a statute. Prior to initiating the contested case proceeding, the department, unless prohibited by statute, may attempt to settle the matter informally.

**13.3(2)** A person who is aggrieved by an action of the department and who is entitled to an evidentiary (contested case) hearing may:

- a. Unless prohibited by statute, request an informal settlement.
- b. Initiate a contested case by submitting a request for a contested case hearing.
- c. Use both procedures.

**13.3(3)** A person may also request that the department resolve a controversy in accordance with rule 761—13.20(17A).

**761—13.4(17A) Submission of request for informal settlement or hearing.**

**13.4(1)** A request to the department for an informal settlement or a request for a contested case hearing shall be submitted in writing to the director of the bureau or division of the department which administers the matter at issue.

**13.4(2)** The request shall include complete names, addresses and telephone numbers for all persons involved and any attorneys representing them. The request shall also specify the mailing address to be used for all communications from the department.

**13.4(3)** A statute or rule may provide for submission of requests within a specified time period. A request shall be considered timely submitted if it is postmarked or delivered to the appropriate bureau or division of the department within the time period specified. Timely submission of a request shall be jurisdictional.

[ARC 6614C, IAB 11/2/22, effective 12/7/22]

**761—13.5(17A) Informal settlement.**

**13.5(1)** An informal settlement may be handled by telephone.

**13.5(2)** If an informal settlement cannot be reached within a reasonable period of time, the department shall notify the person in writing that there has been a failure to reach an informal settlement, that the department's action or decision is sustained, and that the person may request a contested case hearing.

**761—13.6(17A) Contested case decision.** After a contested case hearing, a written decision will be issued by the presiding officer.

**761—13.7(17A) Appeal.** A decision by a presiding officer shall become the final decision of the department and shall be binding on the department and the party whose legal rights, duties and privileges are being determined unless either appeals the decision as provided in this rule.

**13.7(1)** No additional evidence shall be presented on appeal which shall be decided on the basis of the record made before the presiding officer in the contested case hearing.

**13.7(2)** The appeal shall include a statement of the specific issues presented for review and the precise ruling or relief requested.

**13.7(3)** An appeal of a presiding officer's decision shall be submitted in writing to the director of the bureau or division which administers the matter being contested. The appeal shall be deemed timely submitted if it is delivered to the director of the appropriate bureau or division or properly addressed and postmarked within 20 days after the date of the presiding officer's decision.

**13.7(4)** The director of the administering bureau or division shall forward the appeal to the director of transportation.

**13.7(5)** Failure to timely appeal a presiding officer's decision shall be considered a failure to exhaust administrative remedies.

**13.7(6)** The director of transportation may make a decision affirming, modifying or reversing the presiding officer's decision, or may remand the case to the presiding officer.

**13.7(7)** The decision of the director of transportation shall be the final decision of the department and shall constitute final agency action for purposes of judicial review. No further steps are necessary to exhaust administrative remedies.

[ARC 6614C, IAB 11/2/22, effective 12/7/22]

**761—13.8(17A) Motion for review.** The director of transportation may, on the director's own motion, review the presiding officer's decision. The motion for review is subject to the same time limits as an appeal from a presiding officer's decision. If there is a motion for review, subrules 13.7(6) and 13.7(7) apply.

**761—13.9(17A) Rehearings.** An application for rehearing of a final decision under Iowa Code section 17A.16 shall be filed with the director of transportation.

**761—13.10(17A) Maintenance of records.** The department shall retain for at least five years from the date of the final decision copies of the record made before the presiding officer, the decision received from the presiding officer, the decision issued by the director, and related correspondence.

[ARC 1846C, IAB 2/4/15, effective 3/11/15]

**761—13.11(17A) Use of legal assistants or paralegals.** The department may be represented by legal assistants or paralegals at contested case hearings.

These authorized legal assistants or paralegals shall be under the supervision of attorneys from the department's general counsel.

**761—13.12(17A) Communications.**

**13.12(1)** Each party to a contested case shall keep the department informed of the party's current address and telephone number, the name, address and telephone number of the party's attorney, if any, and the mailing address to be used for communications from the department.

**13.12(2)** Mailed notices, communications and decisions regarding the contested case shall be sent by first class or certified mail to the latest address which each party has provided to the department.

**13.12(3)** Notwithstanding subrule 13.12(2), any notices, communications and decisions regarding the contested case issued and sent directly by the department of inspections and appeals may be sent by email or notice of electronic filing as defined by rule 481—16.2(10A) to the party's attorney at the latest email address which the party's attorney has provided to the department of inspections and appeals.

[ARC 6614C, IAB 11/2/22, effective 12/7/22]

**761—13.13(17A) Default.**

**13.13(1)** If a party fails to appear or participate in a contested case proceeding after proper service of notice, the presiding officer may, if no continuance is granted, either enter a default decision or proceed with the hearing and render a decision in the absence of the party.

**13.13(2)** Any party may move for default against a party who has requested the contested case proceeding and who has failed to appear after proper service.

**13.13(3)** A default decision or a decision rendered on the merits after a party has failed to appear or participate in a contested case proceeding becomes final agency action unless, within 20 days after the date of the decision, either a motion to vacate is filed and served on the presiding officer and the other parties or an appeal of a decision on the merits is timely submitted in accordance with rule 761—13.7(17A). A motion to vacate must state all facts relied upon by the moving party which establish that good cause existed for that party's failure to appear or participate.

**13.13(4)** The time for further appeal of a decision for which a timely motion to vacate has been filed is stayed pending a decision on the motion to vacate.

**13.13(5)** Timely filed motions to vacate shall be granted only for good cause shown. The burden of proof is on the moving party. Adverse parties shall have ten days to respond to a motion to vacate.

**13.13(6)** "Good cause" for the purpose of this rule means surprise, excusable neglect or unavoidable casualty.

**13.13(7)** A decision denying a motion to vacate is subject to further appeal in accordance with rule 761—13.7(17A).

**13.13(8)** A decision granting a motion to vacate is subject to interlocutory appeal by the adverse party in accordance with rule 761—13.7(17A).

**13.13(9)** If a motion to vacate is granted and no timely interlocutory appeal has been taken, the presiding officer shall issue another notice of hearing and the contested case shall proceed accordingly.

**761—13.14 to 13.19** Reserved.

**761—13.20(17A) Additional procedures when the department is not a party.**

**13.20(1)** *Jurisdiction.* When the department is required by statute to administer a controversy to which it is not a party, the following additional procedures shall apply.

**13.20(2)** *Request.* A person who has an interest in a controversy and who is entitled to an evidentiary (contested case) hearing may submit a written request to the department to resolve the controversy.

*a.* The request shall state the facts alleged and the relief sought by the requester.

*b.* The request shall identify by name and address the persons involved and any attorneys representing them. The request shall also specify the requester's telephone number and the mailing address to be used for all communications to the requester from the department.

**13.20(3)** *Informal settlement.*

*a.* The department shall contact the persons involved, either by telephone or letter, and shall offer to assist the parties to reach an informal settlement of the controversy.

*b.* A controversy may be settled informally by the persons involved at any time before the department initiates a contested case proceeding.

*c.* When a controversy is settled informally, the persons involved shall each notify the department by telephone and confirming letter that the controversy has been resolved.

**13.20(4)** *Contested case.*

*a.* When the department is notified by a person involved in the controversy that there has been a failure to reach an informal settlement, or when the department determines that no progress toward a settlement is being made, the department shall send a written notice to the persons involved.

*b.* The notice shall specify the following: If the department is not notified of a settlement within 20 days after the notice is mailed, the department shall initiate a contested case proceeding.

These rules are intended to implement Iowa Code chapter 17A and Iowa Code section 10A.801.

[Filed emergency 7/16/75—published 7/28/75, effective 7/16/75]

[Filed 9/11/75, Notice 7/28/75—published 9/22/75, effective 10/27/75]

[Filed 10/2/81, Notice 8/19/81—published 10/28/81, effective 12/2/81]

[Filed emergency 6/22/82—published 7/21/82, effective 7/1/82]

[Filed 9/2/82, Notice 7/21/82—published 9/29/82, effective 11/3/82]

[Filed emergency 6/20/86—published 7/16/86, effective 7/1/86]

[Filed 5/11/87, Notice 3/11/87—published 6/3/87, effective 7/8/87]

[Filed 11/3/88, Notice 9/21/88—published 11/30/88, effective 1/4/89]

[Filed 11/1/89, Notice 9/20/89—published 11/29/89, effective 1/3/90]

[Filed 4/8/99, Notice 2/10/99—published 5/5/99, effective 7/1/99]

[Filed ARC 1846C (Notice ARC 1736C, IAB 11/26/14), IAB 2/4/15, effective 3/11/15]

[Filed ARC 6614C (Notice ARC 6447C, IAB 8/10/22), IAB 11/2/22, effective 12/7/22]



CHAPTER 14

CHAPTER 15

CHAPTER 16

CHAPTER 17

CHAPTER 18

CHAPTER 19



CHAPTER 20  
PROCUREMENT OF EQUIPMENT, MATERIALS, SUPPLIES AND SERVICES

[Prior to 6/3/87, Transportation Department[820]—(01,B)Ch2]

**761—20.1(307) Scope and applicability.**

**20.1(1) *Scope.*** This chapter pertains only to the procurement of equipment, materials, supplies and services by the Iowa department of transportation with funds from the department's operating budget or from the materials and equipment revolving fund established in Iowa Code section 307.47 or other program funds authorized for department use.

**20.1(2) *Applicability.*** Rules 761—20.4(307) through 761—20.6(307) apply to professional and technical services procured using the general purchasing process where contracts are awarded competitively and cost is a factor. Rule 761—20.10(307) applies to professional and technical services contracts that are awarded based on qualifications when the cost is negotiated after the vendor is selected.

[ARC 4341C, IAB 3/13/19, effective 4/17/19]

**761—20.2(307) Definitions.** As used in this chapter, unless the context otherwise requires:

*"Bidder"* means a respondent to a solicitation as a bidder, offeror or contractor.

*"Competition"* means the efforts of three or more parties acting independently to secure a contract with the department to provide equipment, materials, supplies or services to the department by offering or being in a position to offer the most favorable terms. "Favorable terms" includes, but is not limited to: price, speed of execution, anticipated quality of the product to be provided judged according to the expertise and experience of the provider, or ability to produce a desired result or to provide a desired commodity.

*"Department"* means the Iowa department of transportation.

*"Firm"* means any bona fide contracting entity, including individuals and educational institutions. Except for educational institutions, the term shall not include governmental agencies or political subdivisions.

*"Methods of procurement"* means formal advertising, limited solicitation, or negotiation as follows:

1. *"Formal advertising"* means procurement by competition and awards involving the following basic steps:

- Preparing a solicitation that describes the requirements of the department clearly, accurately and completely but avoids unnecessarily restrictive specifications or requirements which might unduly limit the number of responses.
- Distributing the solicitation to prospective bidders and advertising in appropriate media in sufficient time to enable prospective bidders to prepare and submit responses before the time set for public opening of responses.
- Receiving responses submitted by prospective contractors.
- Awarding the contract, after responses are publicly opened, to that responsible bidder whose response conforms to the solicitation and is the most advantageous to the department, price and other factors considered.

2. *"Limited solicitation"* means procurement by obtaining a sufficient number of quotations, bids or proposals from qualified sources:

- As is deemed necessary to ensure that the procurement is fair to the department, price and other factors considered, including the administrative costs of the procurement.
- As is consistent with the nature and requirements of the particular procurement.
- So that the procurement is competitive to the maximum practicable extent.

3. *"Negotiation"* means any method of procurement other than formal advertising or limited solicitation to seek the best and final offer which is most advantageous to the department.

*"Professional and technical services"* means services that are unique, technical, or infrequent functions performed by independent contractors whose occupation is the rendering of such services. Contracts may go to partnerships, firms, or corporations as procured through formal advertising, solicitation or negotiation methods outlined in rules 761—20.3(307) through 761—20.6(307) and architectural, landscape architectural, surveying, general engineering consultant, construction inspection, or engineering services and other related professional and technical services as outlined in rule 761—20.10(307).

*"Response"* means the submittal of written documents by a prospective bidder, offeror or contractor as a response to any type of solicitation issued by the department for a quotation, bid or proposal.

*"Solicitation"* means the request by the department for a quotation, bid or proposal. This includes but is not limited to the complete assembly of related documents (whether attached or incorporated by reference) furnished to prospective bidders for the purpose of responding to a solicitation.

[ARC 4341C, IAB 3/13/19, effective 4/17/19]

**761—20.3(307) Procurement policy.** It is the policy of the department to procure equipment, materials, supplies and services in the most efficient and economical manner possible. It is also the policy of the department that procurement shall be competitive to the maximum practicable extent.

**20.3(1) Formal advertising.** The formal advertising method of procurement shall be used whenever this method is feasible and practicable under the existing conditions and circumstances and the estimated, aggregate amount of the purchase equals or exceeds \$50,000.

**20.3(2) Limited solicitation.** The limited solicitation method of procurement may be used if formal advertising is not feasible or practicable, or the estimated, aggregate amount of purchase is less than \$50,000.

**20.3(3) Negotiation.** The negotiation method of procurement may be used if formal advertising or limited solicitation is not feasible or practicable, or in any of the following instances:

*a.* Procurement by negotiation is determined to be necessary and in the public interest during a period of man-made or natural disaster or emergency.

*b.* The estimated, aggregate amount of the purchase is less than \$5,000.

*c.* The procurement is for architectural, landscape architectural, engineering, or related professional and technical services.

*d.* The procurement is for other professional and technical services.

*e.* When cost is only one of many factors considered to determine the award.

*f.* The procurement is for services to be rendered by an educational institution.

*g.* It is impracticable to secure competition through formal advertising or limited solicitation, such as when:

(1) Equipment, materials, supplies or services can be obtained from only one source.

(2) Competition is precluded because of the existence of patent rights, copyrights, secret processes, control of basic raw materials, or similar circumstances.

(3) Solicitations have been made available to prospective bidders and no responses to the solicitation have been received.

(4) Solicitations have been made available and the submitted responses do not cover the quantity requirements of the solicitation. In this case, negotiation is permitted for the remaining quantity requirements.

(5) The procurement is for electrical power or energy, natural or manufactured gas, water or other utility services, or the procurement is for construction of a part of a utility system or railroad and it would not be practicable to allow a contractor other than the utility or railroad company to perform the work.

(6) The procurement is for professional and technical services in connection with the assembly, installation or servicing (or the instruction of personnel therein) of equipment of a highly technical or specialized nature.

(7) The procurement involves maintenance, repair, alteration or inspection, and the exact nature or amount of work to be done is not known.

(8) The procurement is for commercial transportation.

(9) It is impossible to draft adequate specifications or any other adequately detailed description of the item or services to be procured.

(10) The procurement is for a part or component being procured as a replacement in support of equipment specially designed by the manufacturer, and the data available is not adequate to ensure that the part or component supplied by another manufacturer will perform the same function as the part or component it is to replace.

(11) The procurement involves construction where a contractor or group of contractors is already at work on the site, and either it would not be practicable to allow another contractor or an additional contractor to work on the same site or the amount of work involved is too small to interest other contractors to mobilize and demobilize.

*h.* The procurement is for experimental, developmental or research work or for the manufacture or furnishing of property for experimentation, development, research or testing.

*i.* It is determined that the responses received are not reasonable or have not been independently arrived at.

*j.* Procurement by negotiation is otherwise authorized by law including, but not limited to, Iowa Code section 73.19.

*k.* The manufacturer is willing to sell directly to the state at distributor cost.

[ARC 4341C, IAB 3/13/19, effective 4/17/19]

**761—20.4(307) Formal advertising procedures and requirements.**

**20.4(1) Bidders list.** The department's purchasing section shall maintain current bidders lists by commodity classification.

*a.* These lists are developed using available sources such as technical publications, telephone books, trade journals, commercial vendor registers, advertising literature, Internet resources and targeted small businesses certified

by the Iowa economic development authority. Solicitations will be posted as required on the Iowa economic development authority's targeted small business website no later than 48 hours prior to the issuance of the solicitation.

*b.* Any firm legally doing business in Iowa may be placed on an appropriate bidders list or lists by submitting a written request to: DOT Director of Purchasing, Iowa Department of Transportation, 800 Lincoln Way, Ames, Iowa 50010.

*c.* Subject to concurrence of legal counsel, a bidder's name may be removed from a bidders list or lists for any of the following reasons:

- (1) When the bidder has failed to respond to three consecutive requests for proposals.
- (2) When the bidder has failed to meet the performance requirements of a previous procurement.
- (3) When the bidder has attempted to improperly influence the decision of any state employee involved in the procurement process.

(4) When there are reasonable grounds to believe that there is a collusive effort by bidders to restrain competition by any means.

(5) Where there is a determination by the civil rights commission that the bidder conducts discriminatory employment practices.

*d.* A bidder may appeal removal from a bidders list or lists by submitting the appeal in writing to the department at the address given in paragraph 20.4(1) "b."

**20.4(2) Solicitation documents.** The department shall prepare the solicitation documents complete with requirements, specifications and instructions, as applicable, to be sent (or publicly posted) for the purpose of procuring goods or services.

*a.* In special situations (e.g., the procurement of new model equipment), the solicitation may be marked "preliminary" and sent to prospective bidders requesting their review of the solicitation to determine their ability to respond and meet the requirements of the procurement request. The "preliminary" solicitation process involves the following steps:

(1) A conference may be held to discuss the "preliminary" solicitation requirements with prospective bidders when the item in question is a new acquisition for the department.

(2) Written requests for variations, deviations or approved equal substitutions to the solicitation shall be accepted, evaluated and answered by the department.

(3) The solicitation requirements may be revised to incorporate approved changes.

(4) A final solicitation shall be sent to prospective bidders that participated in the preliminary process.

*b.* The method to be used by the department in evaluating responses received shall be disclosed in the solicitation.

*c.* The solicitation shall be sent to a sufficient number of prospective bidders so as to promote adequate competition commensurate with the dollar value of the procurement.

(1) Generally, the solicitation shall be sent to all bidders listed on the appropriate bidders list for the item to be procured.

(2) However, where the number of names on a bidders list is considered excessive in relation to a specific procurement, the list may be reduced for that procurement by any method consistent with paragraph 20.4(2) "c."

(3) The fact that less than an entire bidders list is used shall not in itself preclude the furnishing of the solicitation to others upon request, or the consideration of responses received from bidders who were not originally included in the bidders list.

*d.* The department shall publicize the procurement by advertising in appropriate media, providing the date and time set for public opening of submitted responses, a general description of the item to be procured, and the name and address of the person to contact to obtain a copy of the solicitation.

**20.4(3) Response instructions.** Each bidder shall prepare the response to the solicitation in the manner prescribed and furnish all information and samples requested in the solicitation. The following shall be adhered to by all bidders when preparing and submitting responses:

*a. Response preparation.* Responses shall be signed and prepared in ink or typewritten in the solicitation documents provided. Telephonic, email or facsimile responses shall not be considered. When available, bidders may respond electronically to a secure authorized system as instructed in the solicitation.

*b. Information to be provided by bidder.* In the space provided, the bidder shall denote brand name, manufacturer's name, model number and any other required information to assist in identifying each item the bidder proposes to supply.

*c. New merchandise.* Unless otherwise specified, all items offered shall be new, of the latest model or manufacture, and shall be at least equal in quality to that specified.

*d. Response price.* Where requested, the unit and total price for each separate item, and the total price for all items, shall be provided in the bidder's response. Alternate prices for approved substitutions may be submitted by attaching a response marked as an alternate to the original response. In case of error, the unit price shall prevail. If unit price is not requested in the solicitation, the total price per item shall prevail.

*e. Discounts.* Bidders shall quote net discount price. No other discounts shall be considered in making the award.

*f. Time of acceptance.* The bidder shall hold the offered prices open for action by the department at least 30 days past the time set for public opening of submitted responses.

*g. Escalator clauses.* Unless specifically provided for in the solicitation, a response containing an escalator clause shall not be considered.

*h. Federal and state taxes.* Except for specific items that will be noted in the solicitation, the department is exempt from payment of federal and state taxes. These taxes shall not be included in the bidder's response. Exemption certificates shall be furnished to bidders upon request.

*i. Delivery dates.* In the space provided, the bidder shall show the earliest date on which delivery can be made. When the solicitation shows the acceptable delivery date for an item, the proposed delivery date may be used as a factor in determining the successful bidder.

*j. Ties and reservations.* No ties or reservations by the bidder are permitted. Any tie or reservation stipulated by the bidder shall be sufficient grounds to reject the submitted response.

*k. Changes and additions.* No changes in or additions to the solicitation shall be permitted unless a written request for a change or an addition is submitted to the department's purchasing section in sufficient time to allow an appropriate analysis and response to all bidders, and the change or addition is approved by the purchasing section. The purchasing section shall notify all bidders of approved changes or additions by means of addenda.

Any unauthorized change in or addition to the solicitation shall be sufficient grounds to reject the submitted response.

*l. Response submission.* All responses shall be submitted in sufficient time to reach the department's purchasing section prior to the time set for public opening of submitted responses. Any response received after the time set for public opening of submitted responses shall be returned to the bidder unopened. Responses received shall be dated and time-stamped by the purchasing section showing the date and hour received. By submitting a response, the bidder:

- (1) Agrees that the contents of the response will become part of the contract if the bidder receives the award.
- (2) Shall be assumed to have become familiar with the contents and requirements of the solicitation.

*m. Proposal guaranty.* A proposal guaranty may be required as security that the bidder will execute the contract if awarded. If required, each response shall be supported by a proposal guaranty in the form and amount prescribed in the solicitation. Responses not so supported shall not be read.

*n. Withdrawal of responses prior to opening.* Responses may be withdrawn prior to the time set forth in the solicitation. Prior to opening, a bidder who withdraws the response to a solicitation may submit a new response if desired.

*o. Modification or withdrawal of responses after opening.* After opening, no response may be modified. A response may be withdrawn after opening only if:

(1) The bidder submits, at least three days prior to award, a sworn statement asserting that the response contains a substantial inadvertent error and that the bidder would suffer a serious financial loss if required to perform under the response, and

(2) The purchasing director approves the withdrawal. The purchasing director may base the decision to approve or deny the withdrawal on any factors the purchasing director deems relevant, including but not limited to the best interests of the agency, possible prejudice to other bidders or the bidding process, and the extent of financial hardship on the bidder if withdrawal is not allowed.

**20.4(4) Public opening of responses.** Responses shall be opened publicly and read aloud at the time stipulated in the solicitation.

**20.4(5) Consideration of responses.** The department reserves the right to accept or reject any or all responses. Individual responses may be rejected for any of the following reasons:

- a.* Noncompliance with the requirements of this rule or of the solicitation.
- b.* Financial insolvency of the bidder.
- c.* Evidence of unfair bidding practices.
- d.* For any other reason stated in this rule.

**20.4(6) Recommendation of award.**

*a. Time frame.* Unless otherwise specified by the department in the solicitation, an award shall be made within 30 days after the date and time set for public opening of submitted responses if it is in the best interest of the state. If

an award is not made within the applicable time frame, the procurement shall be canceled unless an extension of time is mutually agreed to by the department and the apparent successful bidder.

*b. Tied responses.* Responses which are equal in all respects and are tied in price shall be resolved among the tied bidders by giving first preference to an Iowa bidder and second preference to the bidder who satisfactorily performed a contract the previous year for the same item at the same location. If the tie involves bidders with equal standing, the award shall be determined by lot among these bidders. A tied bidder or the bidder's representative may witness the determination by lot.

*c. Tabulation of responses.* A tabulation of responses with an award recommendation shall be sent to all interested parties including bidders at least ten days prior to award.

*d. Protests.* Any protest of the recommended award shall be submitted in writing to: Director of Purchasing, Iowa Department of Transportation, 800 Lincoln Way, Ames, Iowa 50010. A written protest must be received by the director of purchasing within seven days after the recommended award has been posted. The protest shall be considered by the authority making the award. This is not a contested case as defined in Iowa Code section 17A.2.

*e. Return of proposal guaranty.* Unsuccessful bidders' proposal guaranties shall be promptly returned by the department after award is made. The proposed guaranty of the successful bidder shall be returned in accordance with subrule 20.4(7).

**20.4(7) Contract execution and performance.**

*a. Execution.* The successful bidder shall enter into (execute) a formal contract with the department within 14 days after award.

*b. Performance bond and certificate of insurance.* A performance bond or certificate of liability and property damage insurance, or both, may be required for those contracts involving services or specially constructed equipment. If required, the performance bond and certificate of insurance shall be filed with the department within 14 days after award.

*c. Return of awarded bidder's proposal guaranty.* The proposal guaranty of the successful bidder shall be returned following execution of the contract. However, if the successful bidder fails to execute the contract and file an acceptable performance bond and certificate of insurance (if they are required) within 14 days after award, or fails to comply with Iowa Code chapter 490, the award may be annulled and the proposal guaranty forfeited.

*d. Assignment of contract.* The contractor may not assign the contract to another party without written authorization from the department's purchasing section.

*e. Strikes, lockouts or acts of God.* If the contractor's business or source of supply has been disrupted by a strike, lockout or act of God, the contractor shall promptly advise the department's purchasing section. The department may elect to cancel the contract without penalty to either the contractor or to the department.

*f. Payment.* Unless otherwise stated in the contract, payment terms shall be net following the department's receipt and acceptance of the item(s) procured and receipt of an original invoice.

*g. Liquidated damages.* The contract terms may provide for liquidated damages to be assessed if the contractor fails to complete the contract within the contract period or for any other reason as specified in the contract.

**20.4(8) Additional requirements.**

*a.* The department's standard specifications for highway and bridge construction, as available on the department's website at [www.iowadot.gov](http://www.iowadot.gov), where applicable and not in conflict with this rule or with the requirements of a particular procurement, shall apply to formal advertising procurement activities.

*b.* If there are federal funds involved in a particular procurement, and the federal procurement regulations conflict with this rule, then the federal procurement regulations shall apply.

*c.* Procurement of motor vehicles shall be in accordance with Iowa Code section 8A.311(20).

[ARC 4341C, IAB 3/13/19, effective 4/17/19]

**761—20.5(307) Limited solicitation procedures and requirements.**

**20.5(1) Bidders lists.** The department shall use its current bidders lists (see subrule 20.4(1)) to the extent feasible and practicable. However, the solicitation will also be offered to any qualified bidder that has requested an opportunity to participate.

**20.5(2) Form of solicitation.** The solicitation shall be as detailed and complete as practicable for the time and resources available.

**20.5(3) Form of response.** Responses shall be submitted in writing or electronically when practicable. Written responses will prevail over oral responses in case of discrepancies, disputes or errors. Following is the order of preference:

1. Original, signed submitted response.
2. Electronically submitted response (facsimile, email, Internet).

3. Oral response (e.g., telephonic).

**20.5(4) Award.** The award shall be offered to that responsible bidder whose response meets the requirements of the solicitation and is the most advantageous to the department. An Iowa bidder will be given preference over an out-of-state bidder when responses are equal in all respects and are tied in price.

[ARC 4341C, IAB 3/13/19, effective 4/17/19]

**761—20.6(307) Professional and technical services.** This rule applies to professional and technical services procured through the purchasing section using formal advertising, solicitation or negotiation methods outlined in rules 761—20.3(307) to 761—20.6(307). Professional and technical services procured based on qualifications are covered by rule 761—20.10(307).

**20.6(1) Request for proposal (RFP).** A solicitation prepared by the department shall include at least the minimum requirements for the type of goods or services sought. The solicitation is sent to prospective offerors and is publicly posted on the department's website.

**20.6(2) Evaluation committee.** A committee is established for the purpose of reviewing and evaluating proposed responses based on a set of criteria as outlined in the RFP. "Evaluation criteria" will define categories with assigned weighted values to be used as a scoring measure to determine the best overall solution for the department based on technical expertise and price, including but not limited to:

- a. Overall content of written submitted proposal information.
- b. Business knowledge.
- c. Work experience in required skills sets.
- d. Presentation or demonstration.
- e. Cost.

**20.6(3) Award.** The award shall be offered to a firm whose properly submitted compliant response best meets the requirements of the solicitation and receives the highest overall score of the weighted criteria.

[ARC 4341C, IAB 3/13/19, effective 4/17/19]

**761—20.7(307) Sole source or emergency selection.** Sole source or emergency selection applies to all services, including professional and technical services. The department shall fully document and include in the contract file the justification for use of sole source or emergency selection and the basis on which a particular firm is selected.

**20.7(1) Sole source selection.** The department may select a single firm which meets the requirements of the required work categories to perform the work with which to negotiate when one of the following conditions exists:

- a. Only a single firm is determined qualified or eligible to perform the contemplated services or is eminently more likely to most satisfactorily complete the work than another firm.
- b. The services involve work that is of such a specialized character or nature, or related to a specific geographical location, that only a single firm, by virtue of experience, expertise, proximity to or familiarity with the project or ownership of intellectual property rights, could most satisfactorily complete the work.

**20.7(2) Emergency selection.** The department may select a single firm which meets the requirements of the required work categories to perform the work when there is an emergency that will not permit the time necessary to use normal selection procedures. An emergency includes, but is not limited to, one of the following:

- a. A condition that threatens the public health, welfare or safety.
- b. A need to protect the health, welfare or safety of persons occupying or visiting a public improvement or property located adjacent to the public improvement.
- c. A situation in which the department must act to preserve critical services or programs.

[ARC 4341C, IAB 3/13/19, effective 4/17/19]

**761—20.8(307) Conflicts with federal requirements.** If any provision of this chapter would cause a denial of federal funds or services or would otherwise be inconsistent with federal law, federal law shall be adhered to, but only to the extent necessary to prevent denial of the federal funds or services or to eliminate the inconsistency with federal law.

[ARC 4341C, IAB 3/13/19, effective 4/17/19]

**761—20.9** Reserved.

**761—20.10(307) Negotiation—architectural, landscape architectural, engineering and related professional and technical services.** This rule prescribes procedures for the procurement of architectural, landscape architectural, surveying, general engineering consultant, construction inspection, engineering and related professional and technical services by negotiation where selection is based on qualifications in compliance with 23 CFR Part 172. Contract costs are negotiated after a qualification-based selection.

**20.10(1)** *Registration of firms providing professional and technical services.*

a. A firm wishing to provide professional and technical services to the department as a consultant may register to receive information through the GovDelivery portal available at the department's website at [www.iowadot.gov](http://www.iowadot.gov). The firm is responsible for keeping the firm's information updated. For information, persons may contact the consultant coordinator at the Office of Project Management, Iowa Department of Transportation, 800 Lincoln Way, Ames, Iowa 50010, or by telephone at (515)239-1803.

b. The department shall maintain a list of work categories, descriptions and requirements for each work category online.

**20.10(2)** and **20.10(3)** Reserved.

**20.10(4)** *Request for professional and technical services.* Prior to selecting a firm with which to initiate negotiations under this rule, the department shall document the need for outside services, a description of the needed services, the time frame within which the work must be performed, and the method of selection to be used. One of the following methods shall be used to select a firm with which to initiate negotiations:

- a. Complete process. See subrule 20.10(5).
- b. Small contract process. See subrule 20.10(6).
- c. Sole source or emergency selection. See rule 761—20.7(307).

**20.10(5)** *Complete process.* The complete process method will use the following process and will be used unless another selection method is justified.

a. *Request for proposal (RFP).* The department shall prepare an RFP which will include the scope of the work, duration of the contract, list of applicable work categories, evaluation criteria (excluding cost), any established disadvantaged business enterprise or targeted small business goal for the proposed work, type of contract anticipated, submission details including the point of contact for the RFP for any questions, the time by which the RFP should be received by the department and anticipated date of selection. The RFP will not require any cost information to be submitted by the proposing firms.

b. *Website.*

(1) The RFP will be posted on the Iowa department of administrative services' website no later than 48 hours prior to the issuance of the RFP.

(2) The RFP will be posted on the department's website. The notification of the RFP being posted will be sent to all users who have signed up to receive the notification via GovDelivery. The notification will include the link to the website where the RFP is posted. See subrule 20.10(1).

(3) The department will post any questions received on the RFP and answers thereto on the website indicated in the GovDelivery notification.

c. *Selection committee.* The department shall appoint a selection committee to become familiar with the RFP, review the firms that have responded to the RFP to determine if they meet the requirements of the work to be performed, and evaluate the firms that meet the qualifications per the evaluation criteria. The selection committee will, if necessary, interview the firms, score the firms, document the committee's decision and provide the scoring to the consultant steering committee.

d. *Evaluation criteria.* The selection committee is responsible for establishing criteria for evaluating each firm submitting a proposal, assigning weighted values to the criteria, and rating each firm on each criterion. Evaluation criteria are tailored to the needed services. Typical evaluation criteria are listed below. The list is intended as a guideline only; it is not exhaustive, nor is each criterion mandatory.

- (1) Staffing expertise consistent with special project needs.
- (2) Past experience with similar types of work.
- (3) Current workload and commitment of key personnel.
- (4) Specific qualifications of key staff who will be forming the firm's project team.
- (5) Resources the firm has available and proposes to use on the project, including the firm's use of equipment and automated technology and the firm's compatibility with equipment and technology used by the department.
- (6) Identification of proposed subconsultants and the work the subconsultants will perform.

e. *Consultant steering committee.* A consultant steering committee is responsible for reviewing the firms as scored by the selection committee, determining the order of preference for negotiations, and documenting its decision. The number of firms selected shall include at least two alternate firms. The committee shall document its reasoning when the number of selected firms is less than the minimum requirement. The consultant steering committee shall consider not only the selection committee's scoring but other factors such as:

(1) A firm's ability to complete required tasks in the time allotted, taking into account other work currently under contract.

- (2) The volume of work a firm has with the department, both existing and potential.

(3) The department's goal of having a breadth of experienced firms capable of providing quality services to the department.

(4) Other items unique to the particular contract.

*f. Completion of selection process.* After selection committee and consultant steering committee activities are complete, the department shall determine whether negotiations may begin. If negotiations are approved, the department shall proceed to negotiate with the firm that is first in order of preference.

*g. Notification to firms.* The department shall post the results of the selection on the website identified in the GovDelivery notification. For firms not included on the ranked list of firms, the department shall also provide a matrix showing the high, low and average scores for each item evaluated and that firm's score for each item.

**20.10(6) Small contract process.** The small contract process may be used to identify a single firm with which to negotiate when the estimated work under the contract can normally be completed within a 12-month period and the estimated cost of the contract will not exceed \$150,000.

*a. Selection committee.* The department shall appoint a selection committee to identify at least three firms that meet the requirements of the work categories involved in performing the work; document the names of the firms considered, if necessary; interview the firms; select a firm with which to initiate negotiations; and document the committee's decision.

*b. Completion of selection process.* After selection committee activities are complete, the department shall determine whether negotiations may begin. If negotiations are approved, the department shall proceed to negotiate with the selected firm.

**20.10(7) Selection dispute resolution.** Any dispute of the recommended selection shall be submitted in writing to the consultant coordinator. A written notice of the dispute with supporting evidence must be received by the consultant coordinator within 15 calendar days from the date the selection is posted on the department's website. This is not a contested case as defined in Iowa Code section 17A.2. The department will inform the selected firm(s) of the dispute and inform the firm(s) that the department reserves the right to proceed with negotiations with the selected firm(s) pending resolution of the dispute or claim.

**20.10(8) Negotiation of contract.** The purpose of negotiations is to develop a contract that is mutually satisfactory to the department and the selected firm.

*a.* The firm must submit a detailed cost proposal, including a detailed cost proposal for each proposed subcontract. The department shall prepare an independent estimate of the cost of the proposed services, including a detailed estimate of the firm's staff hours needed to complete the contract. Significant differences shall be evaluated and resolved to the satisfaction of both parties. If it is impractical to make an independent estimate, the department shall evaluate the acceptability of the firm's cost proposal on the basis of the reasonableness of the individual elements of the price proposed.

*b.* The department may perform a preaudit. A preaudit typically includes:

(1) An analysis of the firm's cost proposal and financial records for the method of accounting in place to ensure that the firm has the ability to adequately segregate and accumulate reasonable and allowable costs to be charged against the contract.

(2) An analysis of the firm's proposed direct costing rates and indirect overhead factors to ensure the firm's propriety and allowability.

*c.* For contracts with federal funding, the department shall verify federal suspension and debarment actions and eligibility status of firms prior to entering into an agreement or contract.

**20.10(9) Unsuccessful negotiations.** If a mutually satisfactory contract cannot be negotiated, the department shall formally terminate the negotiations and notify the firm in writing. Termination of negotiations is without prejudice and at the department's discretion. The substance of terminated negotiations is confidential.

The department shall then initiate negotiations with the firm given next preference, and this procedure may be continued until a mutually satisfactory contract has been negotiated. If a satisfactory contract cannot be negotiated with any of the selected firms, the department shall either:

*a.* Direct the selection committee to select one or more firms with which to continue negotiations, or

*b.* Redefine the scope of the project or work and start over. See subrule 20.10(4). Once negotiations are terminated, negotiations cannot be reopened with the same firm.

**20.10(10) Evaluation of performance .**

*a.* The department shall evaluate all firms under this rule annually based on the contracts that were active during the fiscal year. Both the firm's performance and quality of the final product shall be evaluated. The evaluation shall consider:

(1) The quality and adequacy of work performed.

(2) The ability to meet established schedules and budgets.

(3) General administration of the contract, including substantiation of cost billings, payments to subconsultants, and documentation of claims.

(4) Cooperation shown by the firm in responding to requests for information and in revising procedures and products according to directions.

(5) Coordination exhibited by the firm in communicating with the department, subconsultants, agencies and others to accomplish tasks and resolve problems.

(6) Ingenuity displayed in solving unique and unusual design problems encountered during performance of contract objectives.

(7) The ability to obtain an acceptable end product with appropriate department staff guidance.

*b.* The firm shall be given an opportunity to review, comment on and sign the evaluation.

[ARC 4341C, IAB 3/13/19, effective 4/17/19]

These rules are intended to implement Iowa Code sections 8A.302(1), 8A.311(20), 73.15 to 73.21, 307.12 and 307.21.

[Filed 7/1/75]

[Filed 4/30/76, Notice 1/12/76—published 5/17/76, effective 6/21/76]

[Filed emergency 7/19/76—published 8/9/76, effective 7/19/76]

[Filed 7/28/83, Notice 6/8/83—published 8/17/83, effective 9/21/83]

[Filed 2/6/87, Notice 12/17/86—published 2/25/87, effective 4/1/87]

[Filed 5/11/87, Notice 3/11/87—published 6/3/87, effective 7/8/87]

[Filed 11/3/88, Notice 9/21/88—published 11/30/88, effective 1/4/89]

[Filed 11/1/89, Notice 9/20/89—published 11/29/89, effective 1/3/90]

[Filed 1/16/03, Notice 11/27/02—published 2/5/03, effective 3/12/03]

[Filed ARC 4341C (Notice ARC 4236C, IAB 1/16/19), IAB 3/13/19, effective 4/17/19]



CHAPTERS 21 to 24  
Reserved



CHAPTER 25  
COMPETITION WITH PRIVATE ENTERPRISE

**761—25.1(23A) Interpretation.** This chapter shall not be interpreted to mean that the department must provide a good or service or will provide a good or service without qualification, restriction, or charge.

**761—25.2(23A) Exemptions.** Activities related to the items listed in this rule are exempted from the provisions of Iowa Code section 23A.2, subsection 1.

**25.2(1)** Transportation-related printing, publications and electronically generated materials including, but not limited to: forms; brochures; booklets; manuals; directories; periodicals; county, city and state transportation maps; video and audio materials; computer tapes and discs; microfilm and other instructional and informative materials.

**25.2(2)** Copies of records or other services provided to meet the requirements of Iowa Code chapter 22.

**25.2(3)** Transportation-related studies, planning and research.

**25.2(4)** Disposal of surplus, obsolete or junked materials and supplies and equipment.

**25.2(5)** Matters of intergovernmental cooperation. Cooperating with other government bodies does not involve providing goods or services to the public except in the broadest sense. The term “government bodies” includes regional transit systems. Activities which involve intergovernmental cooperation include, but are not limited to, the following:

*a.* Use or consumption of departmental facilities, equipment, materials or supplies by other government bodies, including loans, rentals and sales of equipment, materials and supplies.

*b.* Services provided to or performed for other government bodies. These services include:

(1) Vehicle maintenance and repair services provided to other state agencies.

(2) Purchasing services provided to other government bodies.

(3) Purchases made by other government bodies through state contracts.

(4) Disposal of surplus, obsolete or junked materials and supplies and equipment belonging to other state agencies, counties or cities.

(5) Other services performed for government bodies. These services cover a wide range of activities and are performed primarily for county and city highway departments, agencies having park or institutional roads, county treasurers, public transit systems, publicly owned airports, law enforcement agencies, regional planning agencies, and transportation-related boards.

**25.2(6)** Acquisition and disposal of land and improvements acquired for highways or facilities use.

**25.2(7)** Lease of right-of-way.

**25.2(8)** Design, construction, reconstruction, inspection and maintenance of highways including, but not limited to, signs erected in the right-of-way and acknowledgment signs used in the adopt-a-highway and highway helper sponsorship programs.

**25.2(9)** Rescinded IAB 3/13/19, effective 4/17/19.

**25.2(10)** Use or consumption of specialized departmental equipment, materials, supplies or services to complete a contract with the department if the goods or services are not readily available on the open market and the department can provide the goods or services at a competitive price.

**25.2(11)** Use of departmental facilities to complete a contract with the department.

**25.2(12)** Activities related to emergencies including, but not limited to, providing assistance to the public.

**25.2(13)** Goods or services for use or consumption by the department.

**25.2(14)** Use of departmental facilities or services by persons providing services to or representing departmental employees including, but not limited to, the following services or persons: food, credit union and employee organizations.

**25.2(15)** Use of departmental conference rooms or grounds by civic groups and nonprofit organizations.

**25.2(16)** Personal protective items purchased by departmental employees through state contracts.

**25.2(17)** Goods or services promoting transportation or transportation safety.

**25.2(18)** Any other activity permitted or required by law.

[ARC 0187C, IAB 7/11/12, effective 8/15/12; see Delay note at end of chapter; ARC 4341C, IAB 3/13/19, effective 4/17/19; ARC 5256C, IAB 11/4/20, effective 12/9/20]

These rules are intended to implement Iowa Code sections 23A.1 and 23A.2.

[Filed 2/23/89, Notice 1/11/89—published 3/22/89, effective 4/26/89]

<sup>1</sup>[Filed ARC 0187C (Notice ARC 0113C, IAB 5/2/12), IAB 7/11/12, effective 8/15/12]

[Filed ARC 4341C (Notice ARC 4236C, IAB 1/16/19), IAB 3/13/19, effective 4/17/19]

[Filed ARC 5256C (Notice ARC 5122C, IAB 8/12/20), IAB 11/4/20, effective 12/9/20]

- <sup>1</sup> August 15, 2012, effective date of 25.2(8) [ARC 0187C] delayed 70 days by the Administrative Rules Review Committee at its meeting held August 14, 2012. At its meeting held September 11, 2012, the Committee delayed the effective date until adjournment of the 2013 Session of the General Assembly.

CHAPTER 26  
CONSENT FOR THE SALE OF GOODS AND SERVICES  
Rescinded IAB 10/11/06, effective 11/15/06



CHAPTER 27  
INTEREST ON RETAINED FUNDS

**761—27.1(573) Interest on retained funds.**

**27.1(1) Scope.** This rule implements Iowa Code section 573.12, regarding payment to a contractor of interest earned on retained funds. This rule does not address payment of interest under Iowa Code section 573.14.

**27.1(2) General requirements.**

*a.* Interest shall be paid pursuant to Iowa Code section 573.12 only on state contracts awarded on or after July 1, 1990.

*b.* Interest shall be paid on retained funds of a contract only if the accrued interest on those funds is at least \$25. This dollar threshold reflects the cost to the department of processing an interest payment on retained funds.

*c.* Interest shall not be paid on retained funds of a contract declared in default.

**27.1(3) Procedures.**

*a.* Interest shall begin to accrue on retained funds on the date the first progress payment is issued. An interest rate shall be established on this date in accordance with Iowa Code section 12C.6. This interest rate shall apply for the duration of the contract.

*b.* In general, interest shall continue to accrue on retained funds until the date final payment is issued.

(1) Final payment is payment of retained funds less assessed liquidated damages, if applicable.

(2) The final payment and the interest payment shall be by separate warrants. The interest payment shall be issued within two weeks after issuance of final payment.

*c.* Notwithstanding paragraph “*b*,” interest shall cease to accrue on retained funds:

(1) Upon the expiration of 90 days following field acceptance of a project if the contractor has failed to submit to the department the documentation necessary for final payment, as specified in the contract provisions.

(2) Upon payment of retained funds via a retention release voucher. A retention release voucher releases the retained funds and the interest accrued on those funds less assessed liquidated damages, twice the amount of claims on file, and the amount of possible overpayments or adjustments to contract items and change orders. A retention release voucher may be paid at any time after 30 days have expired following completion and final acceptance of the project, if the contractor has submitted the required documentation.

(3) Upon the court’s obtaining jurisdiction of the retained funds pursuant to Iowa Code section 573.16. Retained funds turned over to the court will include the interest accrued on those funds to the date the action was filed, if the interest has not been paid to the contractor.

This rule is intended to implement Iowa Code section 573.12.

[Filed 1/9/91, Notice 11/14/90—published 2/6/91, effective 3/13/91]



CHAPTER 28  
IOWA TRANSPORTATION MAP  
Rescinded **ARC 8243C**, IAB 10/2/24, effective 11/6/24

CHAPTERS 29 to 39  
Reserved



CHAPTER 40  
RECOVERY OF DAMAGES TO HIGHWAYS OR HIGHWAY STRUCTURES

**761—40.1(321) Scope.** This chapter of rules is limited to recovery of damages to highways or highway structures in two situations:

**40.1(1)** As a result of any illegal operation, driving, or moving of a vehicle, object, or contrivance; or

**40.1(2)** As a result of operation, driving, or moving any vehicle, object, or contrivance weighing in excess of the maximum weight in Iowa Code chapter 321 but authorized by a special permit issued pursuant to Iowa Code chapter 321.

**761—40.2(321) Definitions.**

*“Department”* means the Iowa department of transportation.

*“Highway”* means any segment of the primary road system or a municipal extension and includes but is not limited to the pavement surface, shoulder, median, earth fill, ditches and vegetation.

*“Highway structure”* means all the appurtenances of a highway including but not limited to guardrails, culverts, bridges, signs, light poles, attenuators, traffic control devices, or buildings at rest areas, information sites, commercial vehicle inspection and enforcement sites, or other appurtenances adjacent to the highway.

*“Labor additive”* means the labor additive rate approved annually by the Federal Highway Administration. This rate includes indirect labor costs, such as sick leave, vacation, holidays, other leaves with pay and departmental training. The labor additive rate produces an accurate charge for labor costs.

*“Traffic control”* means the labor, materials and equipment used to control traffic through or around the site of an accident on or adjacent to the highway, including but not limited to signs, barricades, signals, pavement markings, and lighting, channelizing, or hand signaling devices.

**761—40.3(321) Information.** Information about the recovery of damages to highway facilities may be obtained from: Office of Finance, Iowa Department of Transportation, 800 Lincoln Way, Ames, Iowa 50010.

**761—40.4(321) Accident scene.** The department shall exclude from recoverable damages the cost of traffic control at the scene of an accident during the period required to conduct the initial investigation, arrange for care of the injured, and either perform cleanup required to return traffic flow to normal conditions or establish a detour.

**761—40.5(321) Repair of facilities.**

**40.5(1)** When notified of a damaged highway or highway structure, the department shall arrange for its repair or replacement by department personnel or by a contractor.

**40.5(2)** The department shall document all of the repair or replacement cost incurred including, but not limited to:

- a. Disposal of remaining debris.
- b. Review and inspection of damaged facility.
- c. Preparation of design plans.
- d. Material and equipment used by the department.
- e. Costs paid to private contractors.
- f. Costs paid to another jurisdiction for a detour route when a highway closure is required.
- g. Traffic control costs incurred during the inspection, repair or replacement.
- h. Labor costs incurred by the department, including labor additive.

**40.5(3)** Rescinded IAB 9/4/02, effective 10/9/02.

**761—40.6(321) Recovery of damages.**

**40.6(1)** The department shall investigate to determine the person(s) responsible for the damages pursuant to Iowa Code section 321.475.

**40.6(2)** The department shall summarize the repair or replacement costs and submit the claim to the person(s) responsible for the damage.

**40.6(3)** The department may seek recovery through civil court action.

**40.6(4)** Collections for recovery of damages shall be deposited in the primary road fund.

These rules are intended to implement Iowa Code section 321.475.

[Filed 1/15/92, Notice 12/11/91—published 2/5/92, effective 3/11/92]<sup>1</sup>

[Filed 8/26/92, Notice 6/24/92—published 9/16/92, effective 10/21/92]

[Filed 8/7/02, Notice 6/26/02—published 9/4/02, effective 10/9/02]

<sup>1</sup> Effective date of 761—40.6(321) delayed 70 days by the Administrative Rules Review Committee at its meeting held March 9, 1992.

CHAPTERS 41 to 99

Reserved

*HIGHWAYS*

CHAPTER 100

FUNCTIONAL CLASSIFICATION OF HIGHWAYS

[Prior to 6/3/87, Transportation Department[820]—(08,C)Ch3]

Rescinded IAB 12/16/98, effective 1/20/99



CHAPTER 101  
FARM-TO-MARKET REVIEW BOARD

**761—101.1(306) Purpose.** The purpose of these procedural rules is to formalize the process by which the farm-to-market review board, created by Iowa Code section 306.6, will administer its duties.

**101.1(1)** Iowa Code section 306.6 requires the farm-to-market review board to make final administrative decisions based on sound farm-to-market road system designation principles for all modifications relative to the farm-to-market road system.

**101.1(2)** Iowa Code section 306.6A requires the farm-to-market review board to adopt procedural rules for modifications to the existing farm-to-market road system and designation of farm-to-market routes on new alignment. These rules implement this requirement.

**101.1(3)** Iowa Code section 306.5 states that the farm-to-market road system shall be a continuous, interconnected system and that provision shall be made for continuity by the designation of extensions within municipalities, state parks, state institutions, other state lands, and county parks and conservation areas.

**761—101.2(306) Definitions.**

*“Area service roads”* or *“local roads”* or *“local road system”* means those secondary roads that are not a part of the farm-to-market road system.

*“Board”* means the farm-to-market review board.

*“Executive board”* means the Iowa county engineers association executive board.

*“Farm-to-market extensions”* means extensions of the farm-to-market road system within municipalities, state parks, state institutions, other state lands, and county parks and conservation areas. The mileage of these extensions of the system shall be included in the total mileage of the farm-to-market road system.

*“Farm-to-market roads”* or *“farm-to-market road system”* means those county jurisdiction intracounty and intercounty roads which serve principal traffic generating areas and connect such areas to other farm-to-market roads and primary roads. The farm-to-market road system includes those county jurisdiction roads providing service for short-distance intracounty and intercounty traffic or providing connections between farm-to-market and area service roads, and includes those secondary roads which are federal aid eligible. The farm-to-market road system shall not exceed 35,000 miles.

*“President”* means the president of the Iowa county engineers association.

**761—101.3(306) Composition and membership of the farm-to-market review board.**

**101.3(1)** The farm-to-market review board shall be composed of 12 county engineers selected by the Iowa county engineers association. Two members shall be selected from each district to serve staggered terms. After the first complete term rotation as shown below, the members shall serve six-year terms. Rotations shall be staggered so that no more than one-sixth of the membership is rotated off the board in any one year. The rotation of board members shall further provide that two members from one district will not be rotated off the board in the same year, and that their rotations will be varied by three years. Board rotation shall be as follows and shall be extended in future years in the same pattern:

| Year |                             | Rotation                    |
|------|-----------------------------|-----------------------------|
| 2015 | District 1 Representative A | District 4 Representative A |
| 2016 | District 2 Representative A | District 5 Representative A |
| 2017 | District 3 Representative A | District 6 Representative A |
| 2018 | District 1 Representative B | District 4 Representative B |
| 2019 | District 2 Representative B | District 5 Representative B |
| 2020 | District 3 Representative B | District 6 Representative B |

**101.3(2)** Members shall be nominated by their districts and approved by the executive board. A county engineer may serve multiple, consecutive terms if so nominated by the county engineer’s district. If a county engineer is unable to complete a term for any reason, the president shall select another county engineer within the district to serve the balance of the term.

**101.3(3)** The farm-to-market review board shall select from its membership a chair and a vice-chair to serve one-year terms. The chair serves at the pleasure of the board and may be elected to multiple terms as deemed appropriate by the board. The vice-chair shall preside at a meeting in the absence of the chair.

[ARC 2392C, IAB 2/3/16, effective 3/9/16]

**761—101.4(306) Collection of system modification requests and frequency of meetings.**

**101.4(1)** The department of transportation will collect applications for modifications to the farm-to-market road system. The board chair shall schedule meetings of the board. In general, the farm-to-market review board shall meet in conjunction with statewide meetings of the Iowa state association of counties and Iowa county engineers association to review accumulated applications for farm-to-market road system modifications. Applications must be filed no less than 30 days prior to each scheduled board meeting. Additional board meetings shall be called as determined by the chair.

**101.4(2)** The farm-to-market review board is required to follow the provisions of Iowa Code chapter 21 with regard to open meetings. The chair shall post a meeting agenda on the Iowa County Engineers Association Service Bureau website and send copies of the agenda to all counties.

**101.4(3)** Minutes of each meeting shall be kept; the chair shall be responsible for the minutes. Meetings may be recorded to facilitate the preparation of meeting minutes, but any recordings made shall not be retained after the minutes have been completed.

[ARC 2392C, IAB 2/3/16, effective 3/9/16; Editorial change: IAC Supplement 8/11/21]

**761—101.5(306) Procedure for requesting modifications to the farm-to-market road system.** To apply for a modification to the farm-to-market road system, a county must file an application through the department of transportation.

**101.5(1)** The application must include the following:

*a.* A copy of a resolution of the county board of supervisors requesting the modification to the existing farm-to-market road system. Farm-to-market modifications may include proposed roads, redesignation of area service roads, or transfers of jurisdiction.

*b.* A report of the county engineer explaining and justifying the addition of new mileage to the farm-to-market road system or the change in the route or farm-to-market classification proposed by the county.

**101.5(2)** In the case of intercounty routes, joint applications may be filed. Resolutions shall be required of each county.

**761—101.6(306) Review criteria for determining eligibility for inclusion of additional roads into the farm-to-market road system.**

**101.6(1)** The farm-to-market review board shall make final administrative determinations based on sound farm-to-market road system designation principles for all modifications relative to the farm-to-market road system.

**101.6(2)** The board shall consider the following factors in making decisions to modify the farm-to-market road system:

- a.* Intracounty and intercounty continuity of systems.
- b.* Properly integrated systems.
- c.* Existing and potential traffic.
- d.* Land use.
- e.* Location of the route.
- f.* Equitable distribution of farm-to-market mileage.

**761—101.7(306) Voting and approval of requested modifications.** Each member is a voting member and is eligible to vote at every meeting at which that member is in attendance. Attendance may include members being present at the meeting through a conference telephone call, Iowa communications network connection, or other electronic means deemed appropriate by the chair.

**101.7(1)** *Determination of a quorum.* A minimum of eight board members is required for a quorum. If a quorum is not present at a meeting, the meeting shall be rescheduled.

**101.7(2)** *Number of votes needed to approve or deny a modification.* For a requested modification to the farm-to-market road system to be approved, it must receive a minimum of seven affirmative votes; in other words, a majority of the entire board. A motion to deny a requested modification need only receive six votes for the denial to be approved.

**761—101.8(306) Report of board decision to applicant county.** Within 30 calendar days after a board meeting, the chair shall send a letter to each county whose request was acted upon by the board at the meeting. The letter shall apprise each applicant of the decision of the farm-to-market review board, briefly explain the reasons for the board's decision, and explain the reapplication and judicial review processes.

**761—101.9(306) Reapplication for modification.** A county may reapply for a modification to the farm-to-market road system if its initial request is denied. The county must again follow all provisions for requesting a modification and should be prepared to present additional information in support of the requested change. Any requested system modification that receives two denials may not be resubmitted for consideration for a minimum of three years.

**761—101.10(306) Judicial review.** Any county that is aggrieved or adversely affected by a decision of the farm-to-market review board may seek judicial review of such agency action under the provisions of Iowa Code section 17A.19.

**761—101.11(306) Adoption and modification of rules.** The chair shall direct the board to review these rules annually. Board members may recommend changes to these rules.

**761—101.12(306) Severability clause.** If any section, provision, or part of these rules is adjudged invalid or unconstitutional, such adjudication shall not affect the validity of these rules as a whole or any section, provision, or part thereof not adjudged invalid or unconstitutional.

These rules are intended to implement Iowa Code sections 306.6 and 306.6A.

[Filed 1/21/99, Notice 12/16/98—published 2/10/99, effective 3/17/99]

[Filed ARC 2392C (Notice ARC 2248C, IAB 11/25/15), IAB 2/3/16, effective 3/9/16]

[Editorial change: IAC Supplement 8/11/21]



CHAPTER 102  
SECONDARY ROAD FUND DISTRIBUTION COMMITTEE  
Rescinded **ARC 8243C**, IAB 10/2/24, effective 11/6/24

CHAPTERS 103 and 104  
Reserved



CHAPTER 105  
HOLIDAY REST STOPS

**761—105.1(307,314) Purpose.** The purpose of this chapter is to establish the requirements and procedures for approving requests for rest stops on primary and interstate highways during holiday periods.

[ARC 3561C, IAB 1/3/18, effective 2/7/18]

**761—105.2(307) General.**

**105.2(1) *Holiday rest stop.*** A holiday rest stop is a location where a nonprofit organization or group serves free refreshments to motorists during holiday periods to provide a break from driving monotony, promote safer driving, and reduce the potential for highway accidents.

**105.2(2) *Free refreshments.*** Free refreshments means water, coffee, cookies, any nonintoxicating, noncarbonated beverage which is not already bottled or canned, doughnuts, or baked dessert goods.

**105.2(3) *Holiday periods.*** Holiday periods shall be limited to:

*a.* Memorial Day weekend and Labor Day weekend, starting at noon on the preceding Friday and ending at midnight between Monday and Tuesday of the holiday weekend.

*b.* The period surrounding Independence Day, starting at noon on July 1 and ending at midnight between July 6 and July 7.

**105.2(4) *Information.*** General information regarding holiday rest stops is available from the Maintenance Bureau, Iowa Department of Transportation, 800 Lincoln Way, Ames, Iowa 50010, or the department's website at [www.iowadot.gov](http://www.iowadot.gov).

[ARC 3561C, IAB 1/3/18, effective 2/7/18; ARC 5607C, IAB 5/5/21, effective 6/9/21]

**761—105.3(307,314) Conditions.** The sponsor of a holiday rest stop shall comply with the following general conditions:

**105.3(1)** The sponsor shall not request or accept payment for the refreshments served. The sponsor may accept voluntary donations using containers clearly labeled with a sign stating "donations." If donation containers are used, the sponsor shall place signs within the immediate area of the operation at locations designated by the department stating "free refreshments."

**105.3(2)** The sponsor shall not distribute any literature or other promotional material.

**105.3(3)** Rescinded IAB 4/3/02, effective 5/8/02.

**105.3(4)** The sponsor shall clean up the area and remove all signs it has erected promptly after the holiday rest stop is discontinued.

**105.3(5)** Parking shall not be permitted on the highway shoulders.

**105.3(6)** The sponsor shall agree to save the department of transportation and the state of Iowa harmless from any liability that may result from the directing of traffic to the holiday rest stop area, and as a result of changes of traffic patterns caused by the activities of the sponsor in or about the holiday rest stop area, and all other liability related to the operation of the special holiday rest stop and the refreshments provided.

[ARC 3561C, IAB 1/3/18, effective 2/7/18]

**761—105.4(307,314) Holiday rest stops on interstate highways.**

**105.4(1) *Site.*** A holiday rest stop along an interstate highway shall be located in an established interstate rest area. The department shall designate an appropriate spot within the rest area for the holiday rest stop. The sponsor shall not use the rest area restroom building or welcome center buildings for the purposes of the holiday rest stop. The sponsor may use the information kiosk where available. A tent or canopy may be used in areas without a kiosk during inclement weather. Running water is available at each rest area. The department will provide electricity if requested.

**105.4(2) *Signs.***

*a.* The sponsor shall not place any signs directing highway traffic to the holiday rest stop. The sponsor shall not place any signs for the holiday rest stop along the interstate highway or interchange ramps. The department shall place signs stating "free refreshments" adjacent to the interstate highway and shall remove these signs when the holiday rest stop is discontinued.

*b.* The sponsor is responsible for any signs posted at the actual holiday rest stop site. Signs provided or placed by the sponsor shall not include any advertising but may include the sponsor's name. Signs shall not be mounted on objects (including vehicles) that contain the name of any organization or individual except the sponsor. The sponsor shall remove all signs it has erected promptly after the holiday rest stop is discontinued.

**105.4(3) *Request.*** A request to sponsor a holiday rest stop in an interstate rest area shall be made on Form 810023. This form is available from the maintenance bureau or the department's website.

*a.* The request shall include the name and address of the requesting sponsor, a detailed description of the proposed holiday rest stop location, and the requested hours of operation.

*b.* The request shall be submitted to the maintenance bureau.

*c.* The request must be submitted at least 30 days prior to the beginning date of the holiday period and shall be accepted up to 12 months in advance.

**105.4(4)** *Approval of request.* The request is subject to the approval of the maintenance bureau.

*a.* A request to sponsor a holiday rest stop shall not be approved until 60 days before the beginning date of the holiday period.

*b.* If there is more than one qualifying request for the same site and date, the sponsor shall be selected by lottery.

[ARC 3561C, IAB 1/3/18, effective 2/7/18; ARC 5607C, IAB 5/5/21, effective 6/9/21]

#### **761—105.5(307,314) Holiday rest stops on primary highways.**

**105.5(1)** *Site.* The proposed site of a holiday rest stop along a noninterstate primary highway will be inspected by the department to ensure it meets the following requirements:

*a.* The site shall be large enough to provide parking space for at least 15 vehicles and located so that all parked vehicles will be at least 50 feet from the edge of the traveled way of the primary highway.

*b.* An access drive from the primary highway shoulder to the parking area shall have a top width of at least 20 feet and shall provide a clear view of the primary highway for at least 900 feet in each direction.

**105.5(2)** *Signs.*

*a.* The sponsor shall not place any signs directing highway traffic to the holiday rest stop. The sponsor shall provide two signs approximately 4 feet by 4 feet announcing the holiday rest stop, one for each highway approach to the site. These signs will be installed by the department, not the sponsor. The department shall remove these signs when the holiday rest stop is discontinued.

*b.* The sponsor is responsible for any signs posted at the actual holiday rest stop site. Signs provided or placed by the sponsor shall not include any advertising but may include the sponsor's name. Signs shall not be mounted on objects (including vehicles) that contain the name of any organization or individual except the sponsor. The sponsor shall remove all signs it has erected promptly after the holiday rest stop is discontinued.

**105.5(3)** *Request.* A request to sponsor a holiday rest stop along a noninterstate primary highway shall be made on Form 810023. This form is available from the maintenance bureau or the department's website.

*a.* The request shall include the name and address of the requesting sponsor, a detailed description of the proposed holiday rest stop location, and the requested hours of operation.

*b.* The request shall be submitted to the maintenance bureau.

*c.* The request must be submitted at least 30 days prior to the beginning date of the holiday period and shall be accepted up to 12 months in advance.

**105.5(4)** *Approval of request.* The request is subject to the approval of the maintenance bureau.

*a.* A request to sponsor a holiday rest stop shall not be approved until 60 days before the beginning date of the holiday period.

*b.* If there is more than one qualifying request for the same site and date, the sponsor shall be selected by lottery.

[ARC 3561C, IAB 1/3/18, effective 2/7/18; ARC 5607C, IAB 5/5/21, effective 6/9/21]

These rules are intended to implement Iowa Code sections 307.12 and 314.27.

[Filed 8/11/93, Notice 6/23/93—published 9/1/93, effective 10/6/93]

[Filed 2/15/94, Notice 1/5/94—published 3/16/94, effective 4/20/94]

[Filed 10/25/95, Notice 8/30/95—published 11/22/95, effective 12/27/95]

[Filed 3/13/02, Notice 2/6/02—published 4/3/02, effective 5/8/02]

[Filed ARC 3561C (Notice ARC 3366C, IAB 10/11/17), IAB 1/3/18, effective 2/7/18]

[Filed ARC 5607C (Notice ARC 5410C, IAB 2/10/21), IAB 5/5/21, effective 6/9/21]

CHAPTER 106  
PROMOTION OF IOWA AGRICULTURAL PRODUCTS AT REST AREAS  
Rescinded **ARC 8244C**, IAB 10/2/24, effective 11/6/24

CHAPTERS 107 to 109  
Reserved  
*RIGHT-OF-WAY AND ENVIRONMENT*

CHAPTER 110  
HIGHWAY PROJECT PLANNING  
Rescinded **ARC 3399C**, IAB 10/11/17, effective 11/15/17



CHAPTER 111  
REAL PROPERTY ACQUISITION AND RELOCATION ASSISTANCE

[Prior to 6/3/87, see Transportation Department[820]—(06,F) Ch 8]

**761—111.1(316) Acquisition and relocation assistance manual.** The September 2017 edition of Section II of the manual entitled “Uniform Manual, Real Property Acquisition and Relocation Assistance” is adopted by reference.

**111.1(1) Contents.** Section II establishes uniform rules and procedures that comply with Iowa law and the Federal Uniform Relocation Act for the acquisition of real property and for the provision of relocation assistance to persons who are displaced from real property as a result of programs and projects.

Relocation assistance is not compensation for real property acquired nor is it compensation for damages to remaining property. Rather, relocation assistance is assistance and compensation provided to a displaced person for making the move and relocating.

**111.1(2) Applicability.**

*a.* In general, Section II applies to any program or project that involves the acquisition of real property or that causes a person to be a displaced person if the program or project:

- (1) Is undertaken with federal financial assistance, or
- (2) Is a road or street program or project undertaken with state financial assistance from the primary road fund, including primary road funds allocated for state park and institutional roads, or
- (3) Is a public road or highway eligible for federal aid.

*b.* In general, Section II applies to any of the following entities that acquire real property or displace a person for a program or project described in paragraph “a”:

- (1) The state of Iowa.
- (2) A political subdivision of the state.
- (3) A department, agency or instrumentality of one or more states or political subdivisions.
- (4) A utility or railroad subject to Iowa Code section 327C.2 or chapter 476, 478, 479, 479A or 479B authorized by law to acquire property by eminent domain.
- (5) Any other person who has the authority to acquire property by eminent domain under state law.
- (6) Any other person who acquires real property or displaces a person for a program or project described in paragraph “a.”

*c.* Any exceptions to paragraphs “a” and “b” are set out in Section II.

*d.* In accordance with Iowa Code subsection 316.9(3), an entity that provides relocation assistance benefits for any program or project is required to provide an appeal process, regardless of the source of funding for the program or project. The appeal process provided shall not diminish the rights of the appellant or the scope of the appeal as described in Section II.

**111.1(3) Availability of manual.** Copies of the manual or portions thereof are available from the Office of Right of Way, Iowa Department of Transportation, 800 Lincoln Way, Ames, Iowa 50010; or on the department’s website at [www.iowadot.gov](http://www.iowadot.gov).

**111.1(4) Future programs or projects.** Failure to comply with Section II when acquiring real property or displacing persons for a program or project may preclude the receipt of future federal financial assistance for the program or project area.

This rule is intended to implement Iowa Code chapter 316 and sections 6B.42, 6B.45, 6B.54, 6B.55 and 310.22.

[ARC 3245C, IAB 8/2/17, effective 9/6/17; Editorial change: IAC Supplement 8/11/21]

[Appeared as Ch 8, Highway Commission, July 1974 IDR Supplement]

[Filed 6/17/74]

[Filed 7/8/77, Notice 5/4/77—published 7/27/77, effective 8/31/77]

[Filed without Notice 9/2/77—published 9/21/77, effective 10/26/77]

[Filed 5/11/87, Notice 3/11/87—published 6/3/87, effective 7/8/87]

[Filed 4/4/90, Notice 2/7/90—published 5/2/90, effective 6/6/90]

[Filed 8/26/97, Notice 7/16/97—published 9/24/97, effective 10/29/97]

[Filed 8/7/02, Notice 6/26/02—published 9/4/02, effective 10/9/02]

[Filed 2/14/06, Notice 1/4/06—published 3/15/06, effective 4/19/06]

[Filed ARC 3245C (Notice ARC 3035C, IAB 4/26/17), IAB 8/2/17, effective 9/6/17]

[Editorial change: IAC Supplement 8/11/21]



CHAPTER 112  
PRIMARY HIGHWAY ACCESS CONTROL  
[Prior to 6/3/87, Transportation Department[820]—(06,C) Ch 1]

**761—112.1(306A,318) Scope and contact information.**

**112.1(1) *Statement of policy.*** All primary highways are controlled access facilities. The efficiency and safety of a highway depend to a large extent upon the amount and character of interruptions to the movement of traffic. The primary cause of these interruptions is vehicular movement to and from public roadways, businesses, residences, and other developments along the highway. Regulation and overall control of highway access are necessary to provide efficient and safe highway operation and to utilize the full potential of the highway investment. Each highway access connection should be located and designed to achieve the least adverse impact to traffic operations and public safety. Accordingly, the department hereby establishes rules for control of access for all primary highways.

**112.1(2) *Contact information.*** Information regarding this chapter may be obtained from the department's website at: [www.iowadot.gov](http://www.iowadot.gov); any of the department's six district offices; or the Traffic and Safety Bureau, Iowa Department of Transportation, 800 Lincoln Way, Ames, Iowa 50010.

[ARC 6562C, IAB 10/5/22, effective 11/9/22]

**761—112.2(306A,321) Definitions.** The following terms, when used in this chapter, shall have the following meanings unless the context otherwise requires:

“*Access*” means a way or means of egress or ingress to a highway.

“*Access connection*” means any point of motor vehicle ingress or egress from or to a highway. It is the physical connection between the edge of the traveled way and the abutting property and is exclusive of the roadway and median.

“*Average annual daily traffic*” or “*AADT*” means the total volume of traffic passing a point or segment of a highway facility in both directions for one year divided by the number of days in the year.

“*Functional area*” includes any area upstream or downstream of an intersection where intersection operation and conflicts significantly influence driver behavior and vehicle operations. The functional area of an intersection is a calculated value based on the intersection's geometrics, posted speed limit, traffic volume, type of traffic control used and perception-reaction-time values determined by the American Association of State Highway and Transportation Officials.

“*Highway*” means the same as “street” or “highway” as defined in Iowa Code section 321.1(78).

“*Intersection*” means the same as defined in Iowa Code section 321.1(33).

“*Necessity*” means the access is required or indispensable to the property because of circumstances that cannot be sufficiently mitigated by other means. Proof of necessity refers to documents, data, maps and other information submitted to illustrate and verify the claim of necessity.

“*Primary highway*” means a highway that is under department jurisdiction.

“*Ramp*” means a special lane, usually a short section of one-way roadway, which provides an access connection between two roads to enter or exit a major highway. The term “ramp” includes but is not limited to entrance ramps, roadway ramps, loop roads and collector-distributor roads.

“*Roadway*” means the same as defined in Iowa Code section 321.1(65). A divided highway has two or more roadways.

“*Traveled way*” means the portion of a roadway used for the through movement of vehicles, excluding shoulders, gutters and auxiliary turn lanes.

“*Trip*” means a single or one-directional vehicle movement. A vehicle leaving the highway and entering a property is one trip, and the vehicle leaving the property and entering the highway is a second trip.

[ARC 6562C, IAB 10/5/22, effective 11/9/22]

**761—112.3(306A) General provisions.** The following provisions govern access encroachments onto a primary highway:

**112.3(1)** No access connection construction activity on a highway shall begin until an access permit has been issued by the department.

**112.3(2)** A new access permit is required when there is a change in use of the access connection. A change in access use includes a change in predominant vehicle types or an increase in traffic volumes or a situation when the use exceeds the design and engineering limitations of the existing access design. If the property owner desires to change from the historical access use or to a use not authorized by the terms and conditions of the existing access permit, a new permit is required.

**112.3(3)** No person shall excavate, fill or make any physical change to any part of the right-of-way without a permit issued by the department.

**112.3(4)** No person shall drive a motor vehicle to or from a highway at a location that is not an authorized access connection.

**112.3(5)** No new access rights shall accrue from, and no additional access shall be provided upon, the splitting or dividing of existing parcels of land or contiguous parcels under the same ownership or controlling interest unless the proposed access complies with access category and design requirements and is permitted. Adjacent properties under common ownership or control, consolidated for development, or part of a phased development plan shall be considered one unit, and a unified access and circulation plan shall be established for the site.

**112.3(6)** No rights of access are conveyed when the department provides a new access connection or modifies an existing access connection.

**112.3(7)** The terms and conditions of any permit are binding upon the applicant, the property owner and all assigns, successors-in-interest, heirs and occupants. Should an assign, successor-in-interest, heir or occupant not accept the terms and conditions of an existing permit, the assign, successor-in-interest, heir or occupant shall apply for a new access permit or a permit to close the access.

**112.3(8)** A property owner not wanting to assume responsibility for an access or its requirements may apply for access removal. Such removal shall be at the property owner's expense unless agreement is made for removal during a highway project.

**112.3(9)** A permit grants no property rights or interests in state right-of-way.

**112.3(10)** Where there are multiple accesses to the same parcel, the department may consolidate existing access connections during a highway project.

**112.3(11)** The department has the authority regarding operational modifications to the highway and all access connections.

[ARC 6562C, IAB 10/5/22, effective 11/9/22]

**761—112.4(17A,306A,318) Permitting process.** An access permit is required for an encroachment onto public right-of-way for the construction, reconstruction or modification of an access connection or any of its related appurtenances.

**112.4(1)** *Application for an access permit.*

a. To obtain an access permit, applicants will use the web-based system found at [www.iowadot.gov](http://www.iowadot.gov). If the applicant cannot use or connect to this electronic system, the applicant may contact the appropriate district office that is responsible for the area in which the proposed access is located. An applicant may be the property owner or the owner's authorized agent.

b. A separate access application and permit is required for each access connection.

c. The department will not act on an application it deems incomplete and shall notify the applicant if additional information is required.

d. Intentional misrepresentation of existing or future conditions or providing false information shall be considered sufficient grounds for denial or revocation of a permit.

e. The applicant is responsible for any location and design plans required to describe the access.

f. The applicant is responsible for providing an estimate of the traffic volume of the access and the property as a whole. The estimate will include the anticipated average daily or hourly use and the anticipated access use upon the full development of the property.

g. For access types A and B as defined in subrule 112.5(2) and public intersections, the department should require a traffic impact analysis from the applicant during the processing of a permit request. Such traffic impact analysis shall be prepared by a professional engineer licensed in Iowa at the cost of the applicant. The analysis will address a current and 20-year projection of traffic activity and impacts at and near the proposed access connection, including the full-development traffic volumes of the access connection.

h. It is the responsibility of the applicant to comply with local ordinances and obtain any other local permits, utility permits or agency approvals that may be required.

**112.4(2)** *Processing an access application.*

a. Upon receipt of an application, the department will begin processing the application using the electronic permitting system. The department will apply the criteria as required by this chapter, including access type, access category, location, design, public safety and traffic operations.

b. The department may issue an access permit with terms and conditions or deny the application if it fails to meet this chapter's requirements. The department representative shall notify the applicant of the determination.

c. The department will not act on an application it deems incomplete and shall notify the applicant if additional information is required.

d. Upon mutual agreement by the department and applicant, the department may suspend or extend the process period.

e. The applicant may withdraw the application.

**112.4(3) Permit terms and conditions.**

a. An access permit shall include terms and conditions necessary to meet the requirements of this chapter and include consideration of the following:

- (1) Safety of the traveling public.
- (2) The access category pursuant to rule 761—112.5(306A).
- (3) The access location and design pursuant to rule 761—112.6(306A).
- (4) The traffic-carrying capacity of the highway.
- (5) Protection of the public investment in the highway.
- (6) Topography and geometric limitations and constraints.

b. The department may restrict turning movements as necessary to reduce adverse impacts. The department will consider the 20-year projection of traffic volumes on the roadway and the full-development traffic volumes of the access connection.

c. Upon issuance of an access permit, the permittee shall initiate construction within one year. An extension may be requested. If the permittee is unable to initiate construction within one year after the permit issue date and no extension is granted, the permit is deemed expired and no longer valid.

d. The property owner and the owner's authorized agent agree by accepting the permit to indemnify, defend and hold harmless the state of Iowa and its employees from all claims arising out of construction or use of the access.

e. The property owner and applicant assume liability for the construction and ongoing use of the access.

f. The permittee shall maintain the access in good repair at all times.

g. If the department has not received the signed copy of the permit within 60 days of the date of transmittal to the applicant, the permit shall be deemed withdrawn.

**112.4(4) Permits where department owns access rights.**

a. This subrule applies only where the department has determined there is no longer the necessity for the controlled access line at the proposed location. The department may issue an access permit if all design and location criteria are met.

b. If it becomes necessary to close the access, the property owner will be notified in advance and any permit will be revoked. The access application and permitting process do not include any rights of appeal where the department is the owner of the access rights.

**112.4(5) Appeals.**

a. An applicant or permittee who objects to any terms or conditions placed on an access permit, the denial of a permit, or the closure or revocation of an access may appeal the department's decision. If the department owns the access rights, this subrule does not apply.

(1) The appeal shall be submitted to the appropriate district engineer at the department.

(2) An appeal concerning the closure or revocation of an access or the denial of a permit must be submitted within 60 days of receipt of the department's notification.

(3) An appeal concerning the terms or conditions placed on an access permit must be submitted within 60 days of when the department sends the applicant the signed copy of the permit with terms or conditions for signature.

(4) The appeal shall include reasons for the request and may include changes, revisions or conditions that would be acceptable to the applicant or permittee.

b. The district engineer shall issue a written decision to the applicant or permittee within 60 days of receipt of the appeal or 60 days after receipt of requested additional information.

c. Upon receipt of the written decision, the applicant or permittee may appeal the district engineer's decision by submitting the appeal along with background information to the director of transportation. The director shall issue a written decision within 60 days of receipt of the appeal. The director's decision shall be the final agency action.

**112.4(6) Waivers.** The director of transportation may, in response to a written petition, waive provisions of this chapter in accordance with 761—Chapter 11. The written petition must contain the information as required in 761—subrule 11.5(2) and shall be submitted to the rules administrator, either by mail to Rules Administrator, Government and Community Relations, Iowa Department of Transportation, 800 Lincoln Way, Ames, Iowa 50010; or by email to the rules administrator's email address listed on the department's website at [iowadot.gov/administrativerules](http://iowadot.gov/administrativerules).

**112.4(7) Waivers involving interstate highways.** The director of transportation shall not waive these rules in access situations involving the interstate highway system, including its ramps, without the approval of the Federal Highway Administration.

[ARC 6562C, IAB 10/5/22, effective 11/9/22]

**761—112.5(306A) Access types and the primary highway category system.** This rule manages access connections according to highway function, design, traffic volumes, speed and roadside conditions.

**112.5(1) General.**

a. The department will assign access categories to all highways according to the descriptions in subrule 112.5(3).

b. There are no minimum or maximum distance criteria for the length of a category assignment.

c. The department may assign a specific category to a segment of highway based on operational needs and to maintain consistency along a specific route.

d. The department will maintain an access category assignment schedule for the highway system.

e. Municipal access categories are for primary highway extensions within municipalities where concurrent jurisdiction applies pursuant to Iowa Code section 306.4(4).

f. For all access categories, access connections should be kept to the minimum necessary to provide reasonable access. A second access to a parcel may be provided only if it meets spacing criteria, internal circulation is not feasible, and there is a necessity for the access.

g. If the category allows type D access, an additional type D access may be granted to a parcel if the necessity due to topography problems or ongoing agricultural activities is demonstrated. A change in use of the parcel of land serviced by the type D access requires a new permit and may require the access be closed if the location will not meet access category requirements for another type.

h. A secondary access for emergency fire services when required by local fire safety regulations may be permitted on all categories except for the categories interstate and freeway (I/F), expressway (E), and municipal expressway (ME) and across controlled access lines. Such emergency access may be permitted only if it is not feasible to provide the emergency access to a secondary roadway. A written explanation with references to local standards from an appropriate government safety official shall be included with the application. The access shall not be open for nonemergency uses and shall be maintained by the permittee as a closed access except during emergencies. Hidden pavement structures are acceptable.

i. Access connections to government parcels will be treated the same as private access types based on volume with the exception of egress access connections used specifically for emergency response services such as fire stations.

**112.5(2) Access types.** Access connections are distinguished by the following four types of private access based on access connection traffic volume:

a. Type A is a private access connection with traffic volumes equal to or greater than 100 trips in a peak hour. Traffic volume estimates are to be based on a 20-year projection or the build-out of the development, whichever is greater.

b. Type B is a private access connection with traffic volumes between 11 and 99 trips in a peak hour. Traffic volume estimates are to be based on a 20-year projection or the build-out of the development, whichever is greater.

c. Type C is a private access connection with traffic volumes between 1 and 10 trips in a peak hour.

d. Type D is a private access connection with an AADT of less than one per day.

**112.5(3) Access categories for highways.** Access categories are distinguished as follows:

a. The interstate and freeway (I/F) category applies to highways with full access control. Access to the roadway, when allowed, shall be provided by ramps. Direct access to the main roadway and all ramps is prohibited without exception.

b. The expressway (E) category applies to nonfreeway multilane highways outside municipal boundaries where the department has acquired the associated access rights. No access that has not already been authorized shall be permitted across existing access control lines. An access management plan is required to authorize a new public intersection. No new direct access connections will be permitted for utilities that have not been previously authorized.

c. The rural-600 (R-600) category applies to two-lane and multilane highways outside municipal boundaries that are on the Iowa commercial industrial network as most recently approved by the commission, or are where roadway traffic volume will be equal or greater than 3,000 AADT within 20 years. Access types A, B and C may be permitted where the applicant can prove necessity and the access has a minimum spacing distance of 600 feet from other connections. Access type D must meet sight distance requirements. Private access connections should not be permitted within the functional area of any public intersection. Public intersections should be located at survey section lines when feasible. Each full-movement access connection should serve as many properties and interests as possible to reduce the need for additional direct access to the highway. Preference shall be given to public intersections.

d. The rural safety and need (R-S/N) category applies to two-lane highways outside municipal boundaries that will not exceed 3,000 AADT within 20 years. This category includes frontage roads, service roads and access ways.

All private access types may be permitted where the applicant can prove necessity and meet sight and spacing distance requirements. Private access connections should not be permitted within the functional area of any public intersection. Public intersections should be located at land survey section lines when feasible.

*e.* The municipal expressway (ME) category applies to nonfreeway multilane highways inside municipal boundaries where arterial performance is necessary to provide high mobility and through traffic capacity. In the absence of an access management plan, no private access shall be permitted that has not already been authorized. An access management plan is required to authorize a new public intersection and may only be allowed if the public roadway is adopted by the city. No access shall be permitted across a controlled access line.

*f.* The municipal-1000 (M-1000) category applies to important regional and intracity highways that are within a municipality. Designation of M-1000 shall include consideration of system continuity and preservation of a high level of mobility and through traffic capacity. The department recommends the installation of restrictive medians between full-movement intersections. Access to an M-1000 may be granted under the following conditions:

(1) All access types are eligible for a full-movement access connection at 1,320 feet (one-quarter mile) locations based on section lines where feasible, and these access connections may be restricted to right-in and right-out turns or directional left-in-only as access volumes increase. A minimum access spacing interval of 1,000 feet should only be permitted if there is a documented necessity. No access connection should be allowed within the functional area of a public intersection.

(2) Each full-movement location should serve as many properties and interests as possible to reduce the need for additional direct access to the highway. Preference shall be given to public intersections.

(3) All access types are eligible for limited movement connections at minimum spacing intervals of 600 feet if a restrictive median is present.

*g.* The municipal-600 (M-600) category applies to highways within municipalities that have been determined to have a need to maintain a moderate level of mobility and through traffic capacity. Minimum spacing for all access types is 600 feet.

*h.* The municipal-300 (M-300) category applies to highways within municipalities where a low level of mobility and through traffic capacity is acceptable. Minimum spacing for all access types is 300 feet.

*i.* The municipal safety and need (M-S/N) category applies to highways within municipalities where motor vehicle mobility and through traffic capacity are low priorities. The granting of access and the determination of access connection locations shall be based only on safety and need.

**112.5(4) *Category revisions.***

*a.* From time to time it may be necessary for the department to change an assigned access category because of changes in roadway conditions, traffic growth or highway reconstruction. Reassignment shall be consistent with subrule 112.5(3). A report shall be prepared presenting why the current category should not be used and the reasons for and benefits of making the category revision.

*b.* If the highway is identified as a future freeway or expressway, the department may suspend the issuance of new access permits.

*c.* If a highway utilizing at-grade intersections is intended to be improved to accommodate traffic growth or safety considerations, the access category of the future improvement shall be applied.

**112.5(5) *Interchange and intersection access control.***

*a.* When it is necessary for an at-grade access connection to be near an interchange on an access category E or ME, the first access connection location will be determined by calculating the functional areas of the expressway ramp and the first at-grade access connection. The two functional areas shall not overlap. The functional area of the ramp shall be considered no less than 1,500 feet from the end of the taper. The first access should be a public intersection. Access turning movements may be restricted for operational reasons.

*b.* Access is prohibited without exception to all elevated structures and ramps on or connected to any highway.

*c.* When the interchange crossroad AADT will exceed 10,000 in the 20th year, the first full-movement access connection should be at least 1,320 feet as measured from the ramp bifurcation point. A minimum of 1,000 feet may be allowed for a full-movement intersection if there is a proven necessity and no reasonable alternative. A restrictive median may be required between the ramps and the full-movement intersection. If the first full-movement intersection is at least 1,200 feet from the ramp bifurcation and a restrictive median is present, a right-in and right-out access may be permitted at a minimum of 600 feet from the ramp bifurcation. The ramp functional area should not overlap with the functional area of any access connection.

*d.* When the interchange crossroad AADT will be between 3,000 and 10,000 within 20 years, the first full movement should be at least 1,000 feet away from the ramp. All access types may have a restricted right-in and right-out access at a minimum of 600 feet from the ramp bifurcation point.

*e.* When the interchange crossroad AADT will not exceed 3,000 within 20 years, access public intersections and private access types A and B should be at least 600 feet away from the ramp bifurcation point. Types C and D should be at least 300 feet from the bifurcation point and may be subject to operational restrictions.

*f.* For any new interchange or interchange reconstruction, access rights should be acquired and extend a minimum of 600 feet away from the ramp bifurcation point. If the AADT will exceed 10,000 within 20 years, a minimum of 1,000 feet of access rights should be acquired.

*g.* Where a free-flow turning movement from a roadway or ramp merges onto another roadway, an analysis shall be completed to determine the functional area and the preferred placement of the first access connection. The functional area of the merge lane of the roadway and the functional area of the first access connection shall not overlap. Access rights shall be acquired along the identified functional area length.

*h.* An at-grade intersection shall be defined by the determination of its functional area. Access should not be allowed within this functional area. Access beyond the functional area remains subject to the requirements of the access category location standards.

*i.* When acquiring access rights as part of a highway project, the department may acquire access rights along intersecting public roadways to protect the operation of the intersection at the highway. Acquisition of access rights should extend a distance of 150 feet from the near edge of the highway traveled way. If the intersecting public roadway AADT is predicted to exceed 3,000 within 20 years, the department should acquire access rights for a distance of 300 feet from the near edge of the highway traveled way. The department may lengthen or shorten the distance of access rights required after considering the intersection functional area, traffic volumes, traffic operations, acquisition costs and other factors.

**112.5(6)** *Access management plans and agreements.*

*a.* Access management plans may be developed to determine how access will be managed on select sections of high-priority corridors, around freeway interchanges, and within municipalities and high-growth corridors. Each plan will apply access management techniques, identify acceptable traffic control features, and establish the necessary operational restrictions to ensure the long-term functional performance and safety of the highway. The scope of each access plan may vary depending on what is determined necessary by the parties of the agreement to manage current and predicted future highway conditions and local land use.

*b.* To apply an access management plan within a municipality, it must be adopted by joint agreement in accordance with Iowa Code sections 306.4(4) and 306A.7.

*c.* Highway projects and corridor plans may include access management techniques and improvements to bring a section of highway into conformance with its current access category without adopting an access management plan and agreement.

[ARC 6562C, IAB 10/5/22, effective 11/9/22]

**761—112.6(306A) Location and design.** This rule sets criteria for the location and design of access connections to primary highways.

**112.6(1)** Each access connection authorized must be located and designed in accordance with this rule. Terms and conditions for location, design, construction and use of the access connection shall be established by permit.

**112.6(2)** The priority of the primary highway system is to provide highway corridors with the goal of maintaining traffic capacity by limiting disruptions to through traffic. Direct access from abutting land is therefore subordinate. Where an adjacent lower traffic volume road is available, the access should connect to that roadway.

**112.6(3)** Private access connections may only be considered when there is a reasonable necessity for the access and should be separated from other private access connections at a minimum distance equal to the sight distance at the posted speed. The burden of proving necessity is on the applicant.

**112.6(4)** An access connection must be consistent with the requirements of the assigned access category.

**112.6(5)** Access location considerations shall include traffic operations, public safety, sight distance, distance to other access locations, traffic speed and volumes, the design vehicle for the access and the allowable turning movements.

**112.6(6)** Restrictive medians may be installed and access connection turning movements may be restricted to right turns or directional left turns for operational reasons when determined necessary and at the sole discretion of the department.

**112.6(7)** Minimum design criteria may be used only when there is a proven and documented necessity that higher standards are not feasible at the specific site.

**112.6(8)** When there are access connections on opposite sides of the highway and left turns are allowed from both directions, the access connections should be opposite each other or have sufficient offset distance so as to prevent overlapping left turn maneuvers.

**112.6(9)** If the access connection requires a turn lane, the access connection should be located so the turn lane can be installed and no other access connections occur along the turn lane. An access should not be installed along a turn lane or taper.

**112.6(10)** Private access connections should not be located within the functional area of a public intersection.

**112.6(11)** All access connections must meet sight distance.

**112.6(12)** The access shall be designed to facilitate the movement of vehicles from the highway to prevent the queuing of vehicles on the roadway.

**112.6(13)** If a proposed access location does not comply with this chapter, the access permit shall be denied.

**112.6(14)** If the department determines that the literal application of these rules to a specific situation will create or result in an unsafe situation or an unreasonable design, the department shall use sound engineering practices to determine the appropriate location and design for the specific situation. The department shall include justification for the design in the permit or the highway project file, as applicable.

[ARC 6562C, IAB 10/5/22, effective 11/9/22]

**761—112.7(306A) Access construction.** This rule sets criteria for the construction of access connections.

**112.7(1) Overall stipulations.**

*a.* Unless part of a public construction project, the construction of the access and its appurtenances as stated in the terms and conditions of the permit shall be completed at the expense of the permittee.

*b.* The access connection shall be constructed according to the department's standards and specifications. The applicant will be provided with the necessary standards and specifications with the issued permit.

*c.* The access shall be completed in an expeditious and safe manner and shall be finished within 30 days from initiation of construction within the highway right-of-way unless otherwise stated on the access permit.

*d.* The department may restrict work within the highway right-of-way, restrict lane closure periods and require preapproval of all aspects of construction phasing and traffic control. The permittee shall provide work zone traffic control at all times during access construction. Work in the highway right-of-way is not allowed on legal holidays, at night, during peak traffic hours or during adverse weather conditions without specific department permission.

*e.* Any damage to the primary highway, appurtenances or any utility or any permitted private encroachment shall be repaired immediately at the direction of the affected owner. All costs associated with repair or relocation will be borne by the permittee. If a survey monument is modified or damaged, repair and replacement shall be done at the direction of the owner of the monument.

*f.* The relocation, removal or modification of any traffic control device or public or private utilities shall be accomplished by the permittee without cost to the department or utility and at the direction of the department or utility owner. A department utility permit shall be obtained for utility work within highway right-of-way.

*g.* An access permit may require installation of traffic control features or devices, but such requirements do not create any type of private interest in such features. Traffic control features and devices in the right-of-way, such as traffic signals, channelizing islands, medians, median openings, and turn lanes are operational and safety characteristics of the highway and are not means of private access. The department may install, remove or modify any traffic control feature or device in the right-of-way to promote traffic safety or efficient traffic operations.

*h.* The department is not obligated to permit or approve any connection, traffic control feature or device or any other site-related improvement that has been specified in a development approval process separate from the permitting criteria and approval process described in this chapter.

*i.* If any construction element of the permitted access fails within three years following construction, the permittee shall be responsible for all repairs. Failure to make such repairs may result in suspension of the permit and closure of the access.

*j.* The property owner or occupants are responsible for maintaining the access. Where the access connection has a paved surface, the property owner or occupants are responsible for maintaining the access connection from the paved edge of the roadway to the right-of-way line. Where the access connection does not have a paved surface, the property owner or occupants are responsible for maintaining the access from the outer shoulder line of the roadway to the right-of-way line. The department is not responsible for the removal of debris, snow or ice on the access, including debris deposited by the department during maintenance operations.

*k.* Drainage structures located along the highway are maintained by the department except for concrete box culverts and bridges constructed by the property owner for access to the property, which shall be maintained by the property owner or occupants.

**112.7(2) Temporary access.**

*a.* When an access is needed in temporary situations for a limited period of time, a temporary access connection may be allowed, but it is subject to special stipulations as determined by the department.

- b. The location of the temporary access shall comply with all safety and sight distance requirements.
  - c. Temporary access shall be authorized only for a specified period of time. In no event shall the period of the permit extend beyond 24 consecutive months.
  - d. The permittee is responsible for all costs incurred, including removal of the access and restoration of the right-of-way at the end of the permit period.
  - e. An application for temporary access is not needed if the temporary access is for department purposes and has been approved in department internal documents and, when required, by the Federal Highway Administration.
- [ARC 6562C, IAB 10/5/22, effective 11/9/22]

**761—112.8(306A) Drainage requirements for access connection approvals.**

**112.8(1)** The permittee shall provide, at the permittee's expense, drainage structures for access connections that will become an integral part of the existing drainage system.

**112.8(2)** The type, size and condition of the drainage structures provided by the permittee shall meet the requirements of the department in unincorporated areas and the requirements of both the department and the municipality in incorporated areas. The design and construction of drainage structures for access shall not adversely impact the highway right-of-way, a storm sewer system or a drainage-way.

**112.8(3)** The construction of an access shall not impair the drainage or stability of the highway subgrade, nor shall it cause water to flow across the roadway pavement or pond on the shoulders or in the ditch or result in erosion within the highway right-of-way.

**112.8(4)** Drainage systems designed and constructed by the department within the highway right-of-way are designed to serve the drainage needs of the highway and adjoining properties based on the basin conditions at the time of the design of the highway.

[ARC 6562C, IAB 10/5/22, effective 11/9/22]

**761—112.9(306A,318) Violations at access connections.**

**112.9(1)** It is the responsibility of the property owner and permittee to ensure that the access is not in violation of this chapter or the terms and conditions of the permit.

**112.9(2)** When an authorized access is constructed or used in violation of this chapter or the terms and conditions of the permit, the department may suspend the access permit and may order the immediate closure of the access. Notwithstanding the preceding sentence or any other provision of this chapter, the department may proceed as authorized under Iowa Code chapter 318 at any time.

[ARC 6562C, IAB 10/5/22, effective 11/9/22]

These rules are intended to implement Iowa Code chapter 17A and sections 306.19, 306A.1 to 306A.8, 307.12, 318.3, 318.5 and 318.8.

[Filed May 18, 1966; amended April 14, 1971]

[Filed 1/17/77, Notice 12/1/76—published 2/9/77, effective 3/16/77]

[Filed 12/20/79, Notice 10/31/79—published 1/9/80, effective 2/13/80<sup>1</sup>]

[Filed 2/7/86, Notice 12/18/85—published 2/26/86, effective 4/2/86]

[Filed 5/11/87, Notice 3/11/87—published 6/3/87, effective 7/8/87]

[Filed 8/8/90, Notice 6/13/90—published 9/5/90, effective 10/10/90]

[Filed 5/17/95, Notice 4/12/95—published 6/7/95, effective 7/12/95]

[Filed 3/7/01, Notice 1/10/01—published 4/4/01, effective 5/9/01]

[Filed 10/10/02, Notice 8/7/02—published 10/30/02, effective 12/4/02]

[Filed 9/14/05, Notice 8/3/05—published 10/12/05, effective 11/16/05]

[Filed ARC 9873B (Notice ARC 9781B, IAB 10/5/11), IAB 11/30/11, effective 1/4/12]

[Filed ARC 2889C (Notice ARC 2779C, IAB 10/26/16), IAB 1/4/17, effective 2/8/17]

[Filed ARC 5301C (Notice ARC 5180C, IAB 9/23/20), IAB 12/2/20, effective 1/6/21]

[Filed ARC 6562C (Notice ARC 6434C, IAB 7/27/22), IAB 10/5/22, effective 11/9/22]

<sup>1</sup> Effective date of [06,C] Ch 1 delayed by the Administrative Rules Review Committee 70 days. Delay lifted by this Committee on March 13, 1980.

CHAPTERS 113 and 114  
Reserved



CHAPTER 115  
UTILITY ACCOMMODATION

[Prior to 6/3/87, Transportation Department[820]—(06,D) Ch 1]

**761—115.1(306A) General information.**

**115.1(1) Scope of chapter.** This chapter covers initial placement, adjustment and maintenance of utility facilities in, on, above or below the right-of-way of primary highways, including attachments to primary highway structures. It embodies the basic specifications and standards needed to ensure the safety of the highway user and the integrity of the highway.

**115.1(2) Information and forms.** Information and forms regarding this chapter may be obtained from any of the department's six district offices; the Office of Traffic and Safety, Iowa Department of Transportation, 800 Lincoln Way, Ames, Iowa 50010; or the Internet Web site: <http://www.iowadot.gov/traffic/index.htm>.

**115.1(3) Considerations.** If the department determines that the literal application of these rules to a specific situation will create or result in an unsafe situation or an unreasonable design, the department shall use sound engineering practices to determine the appropriate design for the specific situation. The appropriate district office shall include justification for the design in the permit or the highway project file, as applicable. The appropriate design shall address:

- a. Safety of motorists, pedestrians, construction workers and other highway users.
- b. Integrity of the highway.
- c. Protection of the rights of the traveling public and of property owners, including the rights of abutting property owners.
- d. Topography and geometric limitations and constraints affecting typical engineering standards.

**115.1(4) Permit approval process.**

a. A district representative may, in response to an application for a utility accommodation on the primary highway system grant approval for a utility permit. The process for inquiring about and applying for a utility accommodation on the primary highway system is through one of the department's six district offices. All applications for utility permits must be applied for in the particular district where the utility accommodation is proposed. A district representative will do one of the following: approve the application for a utility permit, approve the application for a utility permit with conditions, or deny the application for a utility permit. The district representative may use the considerations set forth in subrule 115.1(3) in making the decision. The district representative shall notify the applicant of the determination in writing.

b. Upon receipt of a denial letter or if the permit was approved with conditions, the applicant may choose to pursue a waiver from the director of transportation, pursuant to subrule 115.1(5).

**115.1(5) Waivers.** The director of transportation may, in response to a written petition, waive provisions of this chapter in accordance with 761—Chapter 11. The written petition must contain the information as required in 761—subrule 11.5(2) and shall be submitted to the Rules Administrator, Operations and Finance Division, Iowa Department of Transportation, 800 Lincoln Way, Ames, Iowa 50010.

**115.1(6) Additional requirement for waivers involving interstate highways.** The director of transportation shall not waive these rules in utility accommodation and adjustment situations involving the interstate highway system, including its ramps, without the approval of the Federal Highway Administration.

[ARC 9873B, IAB 11/30/11, effective 1/4/12; ARC 2889C, IAB 1/4/17, effective 2/8/17]

**761—115.2(306A) Definitions.**

*“Adjustment”* means a physical change to an existing utility facility including improvement, rearrangement, reinstallation, protection, relocation or removal of the utility facility.

*“Agreement”* means a contract between the department and a utility owner.

*“Appurtenance”* means a utility facility-related feature such as a vent, drain, utility access or marker.

*“Backfill”* means placement of suitable material and compaction of the material as specified in these rules.

*“Breakaway”* means designed to shatter, bend easily or separate from a solid foundation.

*“Cable”* means an insulated conductor or a combination of insulated conductors.

*“Carrier”* means a pipe directly enclosing a transmitted fluid (liquid or gas) or slurry. “Carrier” also means an electric or communication cable, wire or line.

*“Casing”* means an oversize load-bearing pipe, conduit, duct, or structure through which a carrier or cable is inserted.

*“Cell”* means a conduit.

“*Clear zone*” means that roadside border area, starting at the edge of the traveled way, available for use by errant vehicles.

“*Communication line*” or “*communication cable*” means a circuit for telephone, telegraph, alarm system, television transmission or traffic control purposes.

“*Conduit*” means an enclosed tubular runway for protecting wires or cables. A conduit may also be referred to as a “cell” or “duct.”

“*Cover*” means depth from the grade of a roadway or ditch to the top of an underground utility facility.

“*District representative*” means a department employee who processes utility accommodation requests in an assigned geographical area.

“*Duct*” means a conduit.

“*Emergency*” means an unplanned situation that presents a danger to the life, safety or welfare of motorists, persons working within the right-of-way or the general public and that requires immediate attention. The emergency may be the result of storm damage and may involve disruption of utility service to customers. Work on a utility facility due to an emergency is unplanned work and may be necessary at any time of the day or night. The emergency work operation usually involves a small crew and a work vehicle for a short period of time.

“*Encasement*” means placing a casing around a utility facility.

“*FHWA*” means the Federal Highway Administration.

“*Foreslope*” means the sloping surface of an embankment, ditch, or borrow pit of which the downward inclination is away from the traveled way.

“*Freeway*” means a fully controlled access primary highway. The rights of ingress and egress from abutting properties have been legally eliminated by the department. Permanent access to the highway is allowed only at interchange locations. A freeway is generally five or more miles in length.

“*Highly energized*” means an electrical energy level that could be hazardous if the utility facility is struck or exposed. For purposes of this chapter, voltage exceeding 60 volts is considered to be highly energized.

“*Highway*,” “*street*” or “*road*” means a public way for the purpose of vehicular travel, including the entire area between the right-of-way lines.

“*Interchange*” means a system that provides for the movement of traffic between intersecting roadways via one or more grade separations.

“*Maintenance*” as the term is used in conjunction with a utility facility means any repair or replacement of the utility facility that is not an adjustment and that does not increase the capacity of the original installation. The term “maintenance” when used in conjunction with a highway means repair or other operational activities performed by the department within the highway right-of-way to preserve the function of the highway and its structures.

“*Median*” means that portion of a divided highway separating traffic moving in opposite directions.

“*Multiduct*” means a system comprised of two or more conduits.

“*MUTCD*” means the Manual on Uniform Traffic Control Devices, as adopted in 761—Chapter 130.

“*Nonfreeway primary highway*” means a primary highway that is not a freeway.

“*Occupy the primary highway right-of-way*” means located or to be located in, on, above or below the primary highway right-of-way. The term includes attachments to primary highway structures.

“*Pavement*” means that portion of a roadway used for the movement of vehicles, excluding shoulders.

“*Permit*” means a utility accommodation permit issued by the department. The term “permit” includes any attachments to the permit.

“*Pipe*” means a tubular product used to transport solids, liquids or gases.

“*Pipeline*” means a carrier system used to transport liquids, gases, or slurries.

“*Plowing*” means the installation of a utility line in the ground by means of a plow-type mechanism that breaks the ground, places the utility line and closes the break in the ground in a single operation.

“*Primary highway*” means a road or street designated as a “primary road” in accordance with Iowa Code subsection 306.3(6). This definition includes primary highway extensions in cities and primary highways under construction.

“*Right-of-way*” means the land for a public highway, street or road, including the entire area between the property lines. For purposes of this chapter, the right-of-way line for a freeway is the access control line.

“*Roadway*” means that portion of a highway used for the movement of vehicles, including shoulders and auxiliary lanes. A divided highway has two or more roadways.

“*Rural-type roadway*” means a roadway that does not have as its outside extremities a curb and gutter section.

“*Service connection*” means a water, gas, power, communication, sanitary sewer or storm sewer line that extends from the main or primary utility facility into an adjacent property and that is used to serve the property.

“*Shoulder*” means that portion of a roadway contiguous to the traveled way for the accommodation of disabled vehicles, for emergency use and for the lateral support of the pavement base and surface courses.

“*Toe of foreslope*” means the intersection of the foreslope and the natural ground or ditch bottom.

“*Traveled way*” means that portion of a roadway used for the movement of vehicles, excluding shoulders and auxiliary lanes.

“*Trenched*” means installed in a narrow open excavation.

“*Trenchless*” means installed without breaking the ground or the pavement surface, such as by jacking, boring, tunneling or mechanical compaction.

“*Urban-type roadway*” means a roadway that has as its outside extremities a curb and gutter section.

“*Utility*” means a system for supplying water, gas, power, or communications; a storm sewer, sanitary sewer, drainage tile or other system for transmitting liquids; a pipeline system; or like service systems. The term “utility” includes traffic signal systems and street and intersection lighting systems.

“*Utility access*” means an opening in an underground utility system through which workers or others may enter for the purpose of making installations, inspections, removals, repairs, connections or tests.

“*Utility facility*” means any pole, pipe, pipeline, pipeline company facility, sewer line, drainage tile, conduit, cable, aqueduct or other utility-related structure or appurtenance. However, the term does not include department facilities or the utility lines that service them.

“*Utility owner*” means the owner of a utility facility.

“*Vent*” means an appurtenance used to ventilate or to discharge gaseous contaminants from casings.

**761—115.3** Reserved.

**761—115.4(306A) General requirements for occupancy of the right-of-way.**

**115.4(1)** *Permit required and exceptions to permit.*

*a. Permit required.*

(1) A utility owner shall obtain permission from the department in the form of a utility accommodation permit before it places its utility facilities in, on, above or below the primary highway right-of-way; attaches its utility facilities to a primary highway structure; or adjusts existing utility facilities occupying the right-of-way.

(2) The purpose of the permit process is to ensure the safety of motorists, pedestrians, construction workers and other highway users; to ensure the integrity of the highway; and to document the location of utility facilities for use in managing the highway right-of-way and in locating the facilities in the future.

*b. Exceptions to required permit.*

(1) A permit is not required for storm sewers, subdrains, and lighting designed and constructed as part of a department highway construction project.

(2) A permit is not required for service connections within the corporate limits of a city. These connections require city approval rather than department approval; the utility owner shall apply to the city. However, service connections shall meet all other requirements of this chapter.

**115.4(2)** *Agreement required.* For certain utility facility adjustments, the department may require an agreement between the department and the utility owner. However, the agreement by itself does not constitute a permit nor does it grant permission to occupy the primary highway right-of-way. The utility owner is responsible for obtaining a permit prior to commencing work within the right-of-way. The agreement shall then be attached to and become a part of the permit.

**115.4(3)** *Compliance with requirements.* It is the responsibility of the utility owner to ensure that its utility facility complies with all applicable federal, state, local and franchise requirements and meets generally accepted industry standards at the time of installation.

**115.4(4)** *Performance bond.* The department may require a performance bond for utility work within the highway right-of-way under the following circumstances: the installation is unusual; abnormal site conditions exist, such as but not limited to unstable soil or unique vegetation; or the utility owner has a history of performance problems. A performance bond is required for longitudinal freeway occupancy; see subrule 115.16(9) for specific requirements.

*a.* If a performance bond is required, the utility owner shall file the bond with the department prior to commencing work within the right-of-way.

*b.* The minimum amount of a required performance bond is \$5,000 per permit. Depending on the type and extent of the facility installed, the department may require a higher bond amount. The bond shall be in force for the duration of the permit. The department shall have the right to file a claim against the bond for two years thereafter.

c. The department may accept an annual performance bond in the amount of \$50,000 for statewide activities in lieu of an individual bond for each permit. The statewide performance bond shall be kept in force for as long as the utility owner's facilities occupy the primary highway right-of-way anywhere within the state of Iowa. The department shall have the right to file a claim against the bond for two years thereafter.

d. A performance bond shall guarantee prompt restoration of any damage that is the result of the utility facility's occupancy of the highway right-of-way.

**115.4(5) Execution of work.** Utility construction and maintenance work within the primary highway right-of-way shall be executed in a satisfactory manner and in accordance with good construction practices.

**115.4(6) Disturbance of other contractors.** Utility construction and maintenance work within the primary highway right-of-way shall be accomplished in a manner that minimizes disturbance to any other contractor working within the right-of-way. It is the responsibility of the utility owner to coordinate work with other contractors.

**115.4(7) No adverse effect on highway.** A utility facility shall not adversely affect the safety, design, construction, operation, maintenance or stability of the present use or future expansion of a primary highway.

**115.4(8) Safety, health and sanitation.** Construction and maintenance of a utility facility shall be accomplished in a manner that minimizes disruption of primary highway traffic and other hazards to the highway user. The utility owner shall comply with the MUTCD and all applicable federal, state and local statutes, ordinances and regulations governing safety, health and sanitation. The owner shall furnish such additional safeguards, safety devices and protective equipment and shall take such actions as are reasonably necessary to protect the life and health of the public.

**115.4(9) Parking or storage in clear zone or median.** When not in actual use, vehicles, equipment and materials shall not be parked or stored within the clear zone or median.

**115.4(10) Protection of landscaped or planted areas.** A landscaped or planted area that is disturbed shall be restored as nearly as practical to its original condition. Specific authorization must be obtained from the district representative prior to trimming trees or spraying within the right-of-way.

**115.4(11) Noncompliance.** The department may take any or all of the following actions for noncompliance with any provision of this chapter or any term of a permit:

- a. Halt utility construction or maintenance activities within the right-of-way.
- b. Withhold an adjustment reimbursement until compliance is ensured.
- c. Revoke the permit.
- d. Remove the noncomplying construction or maintenance work, restore the area to its previous condition, and assess the removal and restoration costs to the utility owner.
- e. Place all pending and future permits on hold until the issue is resolved.

**115.4(12) Private utility facility.** A utility facility that is dedicated to private use shall be accommodated in accordance with this chapter. However, the district representative may, when necessary, allow an exception to the cover requirements of subrule 115.13(1) for tile lines and sewer lines.

**115.4(13) Insufficient capacity of right-of-way.** The department shall deny issuance of a permit if it determines there is insufficient room for additional utility facilities within the right-of-way.

#### **761—115.5(306A) General design provisions.**

**115.5(1) Plans.** Design plans for a utility facility shall be prepared by a person knowledgeable in highway design and in work zone traffic control and shall include the measures to be taken to preserve the safe and free flow of traffic, structural integrity of the roadway and highway structures, ease of highway maintenance, appearance of the highway and integrity of the utility facility.

**115.5(2) Materials.** All utility facilities shall consist of durable materials designed for long service life expectancy and be relatively free from routine servicing and maintenance.

**115.5(3) Number of crossings.** The number of utility facilities crossing the primary highway right-of-way shall be kept to a minimum. The department may require distribution facilities to be installed on each side of the highway to minimize the number of crossings and service connections. In individual cases, the department may require several facilities to cross in a single conduit or structure. Crossings should be as near to perpendicular to the highway alignment as practical.

**115.5(4) Aboveground facilities.** The design of aboveground utility facilities shall be compatible with the visual quality of the specific highway section being traversed. See rule 761—115.6(306A).

**115.5(5) Clear zone requirements and aboveground obstructions.** Highway roadsides shall be as free from physical obstructions above the ground as practical. The department shall determine the clear zone distance.

a. The clear zone distance on rural-type roadways is based on present day traffic and the existing foreslope adjacent to and preceding the utility facility.

- b.* Unless otherwise specified, the clear zone shall be measured from the edge of the traveled way.
- c.* In rural areas with rural-type roadways, a permanent, aboveground obstruction is restricted to an area beyond the clear zone or the highway foreslope, whichever area locates the obstruction a greater distance from the edge of the traveled way.
- d.* If sufficient right-of-way is not available to accommodate the clear zone distance, the department may require the utility facility to have a breakaway design, require regrading of the right-of-way, require the utility facility to be located underground, or authorize the facility to be placed near the right-of-way line.

#### **761—115.6(306A) Scenic enhancement.**

**115.6(1) *Introduction.*** The type and size of a utility facility and the manner in which it is installed can materially alter the scenic quality, appearance and view of highway roadsides and adjacent areas. For these reasons, additional controls are applicable in areas that have been acquired or set aside for their scenic quality. Such areas may include, but are not limited to, scenic strips, scenic overlooks, rest areas, recreation areas, public parks and historic sites, aesthetically enhanced corridors, and the right-of-way of primary highways that pass through or are adjacent to these areas. These additional controls are addressed in this rule.

**115.6(2) *Underground installations.*** The department may permit a new underground installation if it does not require extensive removal or alteration of trees or other natural features visible to the highway user and if it does not impair the visual quality of the area being traversed.

**115.6(3) *Aboveground installations.*** The department may permit a new aboveground installation only if the following three conditions are met:

- a.* Other locations for an aboveground installation are unusually difficult, are unreasonably costly, or are less desirable from the standpoint of visual quality.
- b.* Underground installation is not technically feasible or is unreasonably costly.
- c.* The location, design and materials to be used for the proposed aboveground installation will give adequate attention to the visual qualities of the area being traversed.

#### **761—115.7(306A) Liability.**

**115.7(1) *Liability under a permit.*** The following are conditions of a utility accommodation permit.

*a.* The owner of the utility facility shall indemnify and save harmless the state of Iowa, its agencies and employees from any and all causes of action, suits at law or in equity, for losses, damages, claims or demands, and from any and all liability and expense of whatsoever nature (including reasonable attorney fees), arising out of or in connection with the owner's use or occupancy of the primary highway right-of-way.

*b.* The state of Iowa, its agencies or employees, will be liable for expense incurred by the permit holder in its use and occupancy of the primary highway right-of-way only when negligence of the state, its agencies or employees, is the sole proximate cause of such expense. Whether in contract, tort or otherwise, the liability of the state, its agencies, and employees is limited to the reasonable, direct expenses to repair damaged utilities, and in no event will such liability extend to loss of profits or business, indirect, special, consequential or incidental damages.

**115.7(2) *Reserved.***

#### **761—115.8(306A) Utility accommodation permit.**

**115.8(1) *Application for permit.***

*a.* To apply for a utility accommodation permit, the utility owner shall submit an application to the appropriate district representative on a form prescribed by the department.

*b.* If the utility facility will cross or impact a county road connection, the application must be approved by the county. If the facility is within corporate limits of a city, the application must be approved by the city. The utility owner is responsible for obtaining these approvals prior to submitting the application to the department.

**115.8(2) *Permit.***

*a.* At a minimum, a utility accommodation permit allows:

- (1) The applicant (the utility owner) or its representative to perform the work covered by the permit.
- (2) The utility facility described in the permit to occupy the right-of-way.
- (3) The utility facility to be operated and maintained.

*b.* A utility accommodation permit does not convey a permanent right of occupancy.

**115.8(3) *Plan.*** Each permit application shall be accompanied by a plan showing the following:

*a.* Location of the utility facility by route, county, section, township, range, milepost and highway stationing, where these references exist.

*b.* Highway centerline and right-of-way limits.

c. Location of the utility facility by distance to the nearest foot at each point where the facility's location changes alignment, as measured from the:

- (1) Centerline of the highway on nonfreeway installations.
- (2) Right-of-way fence on freeway installations.

d. All construction details including the:

- (1) Depth of burial.
- (2) Types of materials to be used in the installation.
- (3) Operating pressures and voltages.
- (4) Vertical and horizontal clearances.

(5) Traffic control plan prepared by a person knowledgeable in work zone traffic control, or a reference to a standard traffic control plan of the department.

**115.8(4) Discharging into waterways.**

a. A permit application for the placement of a utility facility that will discharge materials into the nation's waters must be accompanied by satisfactory evidence of compliance with all applicable federal, state and local environmental statutes, ordinances and regulatory standards.

b. The utility owner is responsible for obtaining all necessary approvals from the appropriate agencies. The department will not issue a permit until these approvals are obtained.

**115.8(5) Department action on permit application.**

a. The department shall act on the permit application within 30 days after its filing with the appropriate district representative. If an emergency should exist, the department shall act on the application as expeditiously as practical.

b. Failure on the part of the utility owner to provide complete information may result in a delay in the department's taking final action on the application.

**115.8(6) Changes to work.** Changes in the work as described in the original permit require the prior approval of the department.

**115.8(7) Copy of permit at job site.** The utility owner or its contractor shall have a copy of the permit on the construction site at all times for examination by highway officials.

**115.8(8) As-built plans.**

a. Within 90 days after completion of construction, the utility owner shall submit to the district representative an as-built plan or a letter certifying that the actual placement of the utility facility is as described in the original permit.

b. If the utility owner fails to submit the as-built plan or letter within the time required, the department may hire an independent contractor to locate the utility facility and prepare an as-built drawing. All costs associated with this activity are the responsibility of the utility owner.

c. Any costs incurred by the department or its contractors due to incorrect as-built information supplied by the utility owner or deviations in actual placement from that described in the original permit are the responsibility of the utility owner.

**115.8(9) Transfer of permit.** A new utility accommodation permit is not needed when a utility facility is transferred or leased in its entirety. The requirements of the permit and this chapter remain in force for as long as the utility facility continues to occupy the right-of-way and serve its intended purpose. The transferee or lessee shall submit the following information to the appropriate district representative:

- a. The name and address of the transferee or lessee.
- b. Geographical area involved in the transaction.
- c. Designated telephone number for notification purposes.

**115.8(10) Expiration of certain permits.** See subrule 115.16(12) for permits covering longitudinal occupancy of freeways.

**761—115.9(306A) Traffic protection.**

**115.9(1) Traffic control for all work.**

a. When performing work within the right-of-way, the utility owner is responsible for providing, installing, maintaining and cleaning warning signs and protective devices; removing warning signs and protective devices when the work is complete; and providing flaggers.

b. Flagging operations and the placement of warning signs, protective devices, barricades and channelizing devices shall comply with the MUTCD and department requirements for the protection of the traveling public and workers on the site.

c. Flaggers are required at work sites to stop traffic intermittently as necessitated by work progress or to maintain continuous traffic past a work site at reduced speeds to help protect the work crew. For both of these functions the flagger must, at all times, be clearly visible to approaching traffic for a distance sufficient to permit

proper response by motorists to the flagging instructions, and to permit traffic to reduce speed before entering the work site. In positioning flaggers, consideration must be given to maintaining color contrast between the work area background and the flaggers' protective garments.

*d.* The utility owner shall provide additional protection when special complexities and hazards exist.

**115.9(2)** *Traffic control for construction and maintenance work that is not emergency work.*

*a.* The utility owner is responsible for using the types of traffic controls that are adequate for the nature, location and duration of work, type of roadway, traffic volume and speed, and potential hazards.

*b.* Where high traffic volumes cause frequent congestion, routine scheduled maintenance and construction should be avoided during hours of peak traffic.

*c.* Work areas should be occupied for only as long as it is necessary to safely move in, finish the work, remove all utility work signs and move out.

*d.* Special care should be taken to clearly mark suitable boundaries for the workspace with channelizing devices so that pedestrians and drivers can see the workspace. If any of the traveled lanes are closed, tapers shall be used as required by the MUTCD.

*e.* Pedestrians should not be expected to walk on a path that is inferior to the previous path. Loose dirt, mud, broken concrete or steep slopes may force pedestrians to walk on the roadway rather than the sidewalk. Repairs (temporary or permanent) to damaged sidewalks should be made quickly. This may include bridging with steel plates or good quality wood supports.

*f.* Work areas involving excavations on the roadway should not exceed the width of one traffic lane at a time. The work should be staged and, if needed, approved bridging should be used. The utility owner should fully coordinate this type of activity with the district representative or, in a city, with the city's traffic or public works office.

**115.9(3)** *Traffic control for emergency work.*

*a.* The extent of traffic control used for emergency work may be less than that used for longer-term construction or maintenance. However, the utility owner shall provide for the safety of pedestrians, motorists and workers. It may be necessary for the utility owner to contact local law enforcement officials to assist in securing the safety of the traveling public.

*b.* The work vehicle should be equipped with an amber revolving light or amber strobe light, portable signs and channelizing devices, and necessary equipment for flagging operations.

**761—115.10(306A) Construction responsibilities and procedures.**

**115.10(1)** *Permit required before work may begin.* The utility owner shall not commence construction work in the primary highway right-of-way until it has received a utility accommodation permit from the department for the work.

**115.10(2)** *Notice of construction.* The utility owner shall give the district representative at least 48 hours' prior notice of its intent to start construction within the right-of-way.

**115.10(3)** *Authority of the district representative.*

*a.* The district representative has the authority to resolve any issues or concerns that arise regarding the intent of the permit and compliance therewith, as they relate to the condition of the highway.

*b.* During the progress of the work, the district representative may approve minor alterations in the plans or character of the work, as they relate to the condition of the highway, that the district engineer deems necessary or desirable to satisfactorily complete the work. Such an alteration is not a waiver of the permit nor does it invalidate any provision of the permit.

**115.10(4)** *Work in progress.* The utility owner is responsible for the care and maintenance of partially completed work within the right-of-way. Unless otherwise authorized by the permit or the district representative, all work performed within the right-of-way is restricted to a time frame of 30 minutes after sunrise to 30 minutes before sunset.

**115.10(5)** *Authority of department to inspect and approve.*

*a.* The department may inspect and approve any construction work performed within the right-of-way as it relates to the condition of the highway.

*b.* The utility owner shall provide reasonable cooperation.

**115.10(6)** *Department inspectors.* The department may appoint inspectors to represent the department in the inspection of construction. Inspectors are placed on the job to keep the district representative informed of the progress of the work and the manner in which it is being performed, and to call to the utility owner's attention any infringements of the permit. The inspectors shall not:

*a.* Modify in any way the provisions of the permit.

*b.* Delay the work by failing to inspect the work with reasonable promptness.

*c.* Act as a supervisor for the work or perform any other duties for the utility owner or its contractor.

- d. Improperly interfere with the management of the work.
- e. Approve or accept any portion of the work on behalf of the department.

**115.10(7) *Repair and cleanup.*** Prior to the department's final inspection, the utility owner shall:

- a. Upon notification by the department, immediately make any repairs to the right-of-way that are necessary due to the construction work.
- b. Remove from the right-of-way all unused materials and rubbish resulting from the work and leave the right-of-way in a clean, presentable condition.

**115.10(8) *Final inspection.***

- a. Upon notification by the owner of the utility facility or its authorized representative that the work is complete, the district representative may inspect each item of work included in the permit as it relates to the condition of the highway.

b. If the district representative finds that the work is not in compliance with the permit, the district representative shall provide to the utility owner written notice of the particular defects found. The owner is responsible for remedying these defects in a timely manner.

#### **761—115.11(306A) Vertical overhead clearance requirements.**

**115.11(1) *Conformance to standards.*** The vertical clearance for overhead utility facilities and the lateral and vertical clearances for bridges shall conform to accepted industry standards as well as applicable codes and regulations.

**115.11(2) *Minimum vertical clearance.*** In no event shall the vertical clearance be less than 20 feet above the roadway for all overhead utilities.

#### **761—115.12(306A) Utility facility attachments to bridges.**

**115.12(1) *Electrical power and communication cable attachments.***

a. An electrical power or communication cable may be attached to an existing primary highway bridge if the department determines that the attachment is in the best interests of the public. The department may accommodate an electrical power or communication cable attachment in its design for a new bridge if the department determines that the accommodation is in the best interests of the public.

b. The permit application shall include a detailed sketch showing the method of attachment and weights of attachment. A separate permit is required for each bridge.

c. All attachments shall be placed in conduits, pipes or trays; beneath the bridge's floor; and above low steel or masonry of the bridge. Department-approved clamps shall be used for any attachment to structural steel.

d. Expansion devices are required. Cables in cells or casings shall be grounded wherever necessary. Carrier pipe shall be suitably insulated from electrical power line attachments.

e. All costs attributable to the installation of an attachment to a bridge shall be paid by the utility owner unless the attachment is installed pursuant to a utility agreement.

f. Welding or drilling holes in structural steel primary members is prohibited.

g. Utility facilities may be attached to noncritical concrete areas.

h. Holes should not be cut in wing walls, abutments or piers.

**115.12(2) *Pipeline attachments.***

a. Pipelines may be attached to primary highway bridges when installation below ground is not feasible, the design of the bridge can accommodate the attachment, and space is available.

b. The permit application shall include a detailed sketch showing the method of attachment and weights of attachment. A separate permit is required for each bridge.

c. Pipes shall be placed beneath the bridge's floor, inside the outer girders or beams (or in cells specifically designed for the installation), and above low steel or masonry of the bridge.

d. Pipes shall be designed to withstand expected expansion or contraction forces. If necessary, expansion devices such as expansion joints, offsets or loops shall be used.

e. Pipelines in cells or casings shall be vented and grounded whenever necessary.

f. Pipelines that have an operating pressure of more than 75 pounds per square inch or that are larger than two inches in diameter shall have shutoffs not more than 300 feet from each end of the bridge.

g. The department shall consider casing requirements on an individual basis. In some instances, thicker-walled or extra-strength pipe may be considered in lieu of encasement. Encasement is required for plastic pipe attachments to bridges.

h. All costs attributable to the installation of an attachment to a bridge shall be paid by the utility owner unless the attachment is installed pursuant to a utility agreement.

- i. Welding or drilling holes in or attaching to structural steel primary members is prohibited.
- j. Utility facilities may be attached to noncritical concrete areas.
- k. Holes should not be cut in wing walls, abutments or piers.
- l. The utility owner shall provide an indemnity bond to be executed by either itself or by a responsible bonding company, at the department's option.

(1) The indemnifier under the bond shall, in the event of damage resulting from any cause whatsoever arising out of or from permission to attach a pipeline, indemnify the department against all loss or damage to it or any third party therefrom, including but not limited to the expense of repairing or replacing the bridge and the cost of alternate highway facilities for traffic during the period when the bridge is being repaired or replaced.

(2) The indemnity bond shall be kept in force for as long as the pipeline is attached to the bridge. The department may periodically review the amount of the bond and require adjustments in the bond amount.

**115.12(3) Attachment fee.**

a. The utility owner shall pay to the department an attachment fee for attaching its utility facility to a primary highway bridge. The attachment fee is \$100 per bridge plus \$0.55 times the weight of the attachment in pounds per foot times the length of bridge in feet. The fee shall increase 3 percent per year after the base year of 2004.

b. The attachment fee is due before any construction work commences within the right-of-way.

c. Utility facilities belonging to or exclusively serving a city may, if the department considers it desirable, be attached to a primary highway bridge without assessment of an attachment fee.

**115.12(4) Engineering fee.** When a primary highway bridge is in the planning stages and the department designs the bridge to accommodate a requested attachment, the department shall assess to the utility owner an engineering fee. The engineering fee shall reimburse the department for the department's increased costs of design, construction and inspection due to the attachment. The department shall bill the fee to the utility owner when the department's work is complete.

**115.12(5) Utility attachments to freeway border bridges.** The department may permit a utility facility to be attached to an existing or planned freeway border bridge if the following conditions are met:

a. The appropriate state agency of the adjoining state approves the attachment.

b. Except for communication cable, the facility exits the freeway right-of-way as soon as physically practical after crossing the state line into Iowa.

c. The attachment otherwise complies with this chapter, specifically including this rule on attachments and rule 761—115.16(306A) on longitudinal freeway occupancy.

**761—115.13(306A) Underground utility facilities.**

**115.13(1) Depth requirements.**

a. *Minimum cover—roadway.* The minimum required cover under a roadway is 48 inches.

b. *Minimum cover—other portions of right-of-way.* The minimum required cover under other portions of the right-of-way is:

(1) 48 inches for electrical cable.

(2) 30 inches for communication cable except that 36 inches is required for longitudinal occupancy under freeway right-of-way.

(3) 36 inches for all other underground facilities.

c. *Rocky terrain.* The department may allow an exception to the minimum depth requirement where rocky terrain makes it difficult to obtain the required depth. The department shall determine the minimum depth in these situations; however, no installation shall be authorized with less than 24 inches of cover.

d. *Other protective measures.* In critical situations where the necessary cover cannot be obtained, the department may approve other protective measures.

**115.13(2) Measurement of cover.** The cover is measured from one of the following:

a. On rural-type roadways, the lowest pavement surface edge.

b. On urban-type roadways, the gutter flow line, excluding local depressions at inlets.

c. Where longitudinal installations will be behind the curb, the top of the curb.

d. The surface of the surrounding ground or the low point of the ditch.

**115.13(3) Casing.** A casing shall:

a. Protect the highway from damage.

b. Protect the carrier pipe from external loads or shock, either during or after construction of the highway.

c. Convey leaking liquids or gases away from the area directly beneath the traveled way.

d. Provide for repair, removal and replacement of the utility facility without interference to the highway.

**115.13(4) Seals.** Casing pipe shall be sealed at both ends with a suitable material to prevent water or debris from entering the annular space between the casing and the carrier, in accordance with generally accepted industry standards.

**115.13(5) Transverse occupancy—encasement and related requirements.**

*a. Trenchless construction.* Underground transverse crossings of existing paved roadways shall be made by trenchless construction whenever practical. Any exception to this requirement must be specifically authorized by the district representative and noted in the permit.

*b. Electrical service.* Underground electrical service must be placed in a conduit from right-of-way line to right-of-way line and shall be clearly marked by the utility owner at the outer limits of the right-of-way.

*c. Pipelines.*

(1) Except as set out in 115.13(5) "c"(2), a pipeline carrying natural gas at an operating pressure of greater than 60 pounds per square inch, liquid petroleum products, ammonia, chlorine or other hazardous or corrosive products shall be encased from right-of-way line to right-of-way line.

(2) Encasement of a pipeline carrying a product listed in 115.13(5) "c"(1) is not required if the pipeline meets all of the following requirements and the utility owner certifies as a part of the permit that these requirements are met:

- It is welded steel pipeline.
- It is cathodically protected.
- It is coated in accordance with accepted industry standards.
- It complies with federal, state and local requirements and meets accepted industry standards regarding wall thickness and operating stress levels.

(3) A pipeline carrying a product listed in 115.13(5) "c"(1) shall be vented and marked at the outer right-of-way limits. The markers shall comply with accepted industry standards and include the following information: name and address of the owner, telephone number to contact in case of an emergency, and type of product carried.

(4) Encasement of a natural gas pipeline with an operating pressure that is not greater than 60 pounds per square inch is not required if the pipeline is made of copper, steel or plastic; the pipeline is protected and installed in accordance with accepted industry standards; and the utility owner certifies as a part of the permit that these standards are met. Otherwise, encasement is required.

*d. Communication cable.* The department may require encasement of communication cable.

*e. Sanitary sewer lines.* Sanitary sewer lines, both gravity and force mains, shall be encased from right-of-way line to right-of-way line. Exception: A gravity flow line that is installed subsequent to highway construction need not be encased if it will meet all of the following requirements:

(1) The opening is cut to the size of the carrier pipe so that there are no excessive voids around the pipe.

(2) The pipe is of sufficient strength to withstand the external loads created by the vehicular traffic on the roadway being traversed.

(3) Lines beyond the toe of foreslope are properly embedded.

*f. Waterlines.* Waterlines shall be encased from right-of-way line to right-of-way line. Exceptions:

(1) Encasement is not required where it is impractical due to existing conditions, as determined by the district representative. As a minimum, waterlines shall be encased from toe of foreslope to toe of foreslope.

(2) Waterlines with an inside diameter of two inches or less need be encased only from toe of foreslope to toe of foreslope. Venting and sealing of the encasement are not required.

(3) Properly embedded waterlines that are installed prior to highway construction need not be encased if extra strength cast iron or ductile iron pipe with mechanical joints and seals, or equivalent, is used from right-of-way line to right-of-way line.

*g. Installations vulnerable to damage.* Utility facilities that by reason of shallow depth or location are vulnerable to damage from highway construction or maintenance operations shall be protected with a casing, suitable bridging, concrete slabs or other appropriate measures.

*h. Other installations.* When it is acceptable to both the utility owner and the department, an underground utility facility not otherwise addressed in this subrule may be installed without protective casing if the installation involves trenched construction or small bores. Encasement requirements will be determined on an individual basis.

**115.13(6) Longitudinal occupancy—encasement and related requirements.**

*a.* Utility lines installed longitudinally to the primary highway right-of-way shall be encased at crossings of hard-surfaced side roads, streets and entrances in accordance with subrule 115.13(5).

*b.* Reserved.

**115.13(7) Multiduct systems.** The department may require installation of a multiduct system to be shared with others. Details of the installation are subject to department approval.

a. The department shall designate a "lead company" for the system. The lead company is generally the first utility owner requesting occupancy. The lead company is responsible for:

- (1) Design and construction of the multiduct system.
- (2) Maintenance of the multiduct system.
- (3) Providing all capital required to construct the multiduct system.

b. Once a multiduct system has been established, the department shall require future occupancies to be located within one of the unoccupied inner ducts of the system. If all inner ducts are occupied, the department may require the establishment of an additional multiduct system.

c. Each occupant of a multiduct system shall share equally in the entire capital costs of the facility. As each new occupant is added to an existing system, the department shall require the new occupant to pay its proportionate share based on the number of inner ducts it occupies.

d. See subrule 115.16(8) for occupancy fees for longitudinal installations on freeways.

**115.13(8) Procedures for backfilling trenched construction and jacking or boring pits.**

a. When a carrier, pipe, conduit, or cable is placed by trenched construction, the backfill shall be placed and compacted so that there is no settlement or erosion. If settling or erosion of a trench is observed, it is the responsibility of the utility owner to correct the problem.

b. Jacking or boring pits shall be backfilled in the same manner as that described in paragraph "a" of this subrule.

c. Backfill under roadways or entrances shall be of a suitable material to minimize settlement. Examples of suitable material include granular backfill or flowable mortar.

**115.13(9) Procedures for trenchless construction.**

a. When trenchless construction techniques are used, the bore shall be as small as practical and in no case more than four inches larger than the facility or casing inserted.

b. Grout backfill is required for all unused holes and abandoned pipes. Grout or sand backfill is required for any borehole more than two inches larger than the installed casing or other facility. All bored facilities shall be constructed in such a manner that surface water is not transported to or otherwise allowed access to groundwater.

**115.13(10) Procedures for pavement removal.**

a. When the existing pavement must be cut to accommodate a utility installation, the cut shall be made with a concrete saw.

b. The width of the pavement removal shall be a minimum of six feet. If the distance from the specified cut to any adjacent longitudinal or transverse joint or crack is less than four feet, the pavement shall be removed to that joint or crack.

c. The district representative shall make the final determination on the required depth and width of cut.

**115.13(11) Procedures for pavement replacement.**

a. Restoration of pavement shall be accomplished in accordance with methods approved by the district representative.

b. The district representative may authorize temporary repair with bituminous material.

c. A permanent patch shall be placed as soon as conditions permit.

**115.13(12) Clear zone for pits.**

a. On freeways, jacking or boring pits are not allowed within the median. A jacking or boring pit shall be located in an area beyond the clear zone or the highway foreslope, whichever area locates the pit a greater distance from the edge of the traveled way, right-of-way width permitting.

b. On rural-type, nonfreeway primary highways, jacking or boring pits are not allowed within the median. A jacking or boring pit shall normally be located in an area beyond the clear zone or the highway foreslope, whichever area locates the pit a greater distance from the edge of the traveled way, right-of-way width permitting. However, a jacking or boring pit may be allowed within the foreslope if it is specifically authorized by the district representative and noted in the permit.

c. On urban-type, nonfreeway primary highways, jacking or boring pits should be located at least two feet back from the curb.

d. Jacking or boring pits authorized within the clear zone shall be protected at all times. Protection may include backfilling of the pit, temporary barrier rail, reflective fence, or other measures. All measures must be approved by the district representative.

**115.13(13) Construction methods.** Casing and pipeline installations shall be accomplished by dry boring, tunneling, jacking, trenching, directional drilling or other approved methods.

a. The use of water under pressure (jetting) or puddling to facilitate boring, pushing or jacking operations is not allowed.

*b.* However, a boring operation that requires the use of water only to lubricate the cutter and pipe is considered dry boring and is allowed.

**115.13(14) Encasement material.** It is the responsibility of the utility owner to ensure that it complies with all applicable federal, state, local and franchise requirements and meets generally accepted industry standards in the selection of encasement materials.

**761—115.14(306A) Freeways.**

**115.14(1) Access to utility facilities occupying freeway right-of-way.**

*a.* Except for emergency work, access shall not be obtained from the freeway or its ramps during utility construction or maintenance operations. This means that access must be obtained from intersecting, adjacent or nearby public highways, streets, roads or trails or from private property. See subrules 115.9(3) and 115.19(2) for emergency work.

*b.* Fence removal and replacement are subject to the limitations imposed by the permit.

*c.* No gates or ladders shall be placed in or upon the right-of-way fence.

*d.* The department shall notify the FHWA of any access it authorizes to the interstate system for utility work.

**115.14(2) Freeway clear zone requirements.** The clear zone requirements of subrule 115.5(5) apply to freeways. In addition:

*a.* On freeways open to traffic, personnel, equipment or materials are not allowed in the median or within the clear zone area, right-of-way width permitting, during utility facility construction or maintenance operations, except for the stringing of transverse overhead conductors.

*b.* In the interest of safety and when considered advisable, the district representative may authorize the placement of temporary poles in the median during cable or conductor stringing operations.

**115.14(3) Aboveground appurtenances.** Unless otherwise provided, aboveground appurtenances are not allowed within the right-of-way of freeways.

**115.14(4) Existing facilities.**

*a.* A utility facility occupying land that subsequently becomes freeway right-of-way may remain within the right-of-way if the facility:

(1) Can be accessed from other than the freeway or its ramps.

(2) Does not adversely affect the safety, design, construction, operation, maintenance or stability of the freeway.

*b.* If these conditions are not met, the facility shall be relocated.

**761—115.15(306A) Transverse installations on freeways.**

**115.15(1) Interchange areas.**

*a.* Utility facilities are not allowed within the interchange area of intersecting freeways unless they are highway-related.

*b.* In other interchange areas, the department may permit occupancy if access to the utility facility can be obtained from other than the freeway or its ramps. If a utility facility cannot reasonably be accessed from an intersecting, adjacent or nearby public highway, street, road or trail, the utility facility shall be installed on private property outside the interchange area.

**115.15(2) Aboveground installations.**

*a.* Poles, guys and other supporting structures and related aboveground facilities should be located outside the freeway right-of-way. A single span shall be used to cross the freeway where the width of freeway right-of-way permits.

*b.* Within interchange areas:

(1) Single-pole construction shall be used, with the number of poles kept to a minimum.

(2) Overhead lines shall be constructed on tangent, parallel to the intersecting road, without guys or anchors being placed in the areas between the ramps and the main roadways of the freeway. Guy poles shall be located as near to the freeway right-of-way line as practical.

(3) Poles should be located as close to the toe of foreslope of the intersecting road as practical, but shall remain outside the clear zone.

(4) Poles should be located as far from the main roadways and ramps of the freeway as practical. No poles are allowed within the median or within the clear zone along the ramp pavement and the freeway pavement.

(5) The use of self-supporting poles or towers, double arming and insulators, breakaway devices and dead-end construction should be considered.

**115.15(3) Encasement requirements.** Underground facilities crossing the freeway shall be encased from right-of-way-line to right-of-way line. Exception: Encasement of a pipeline carrying natural gas at an operating pressure of

greater than 60 pounds per square inch, liquid petroleum products, ammonia, chlorine or other hazardous or corrosive products is not required if the pipeline meets the requirements of subparagraph 115.13(5) "c"(2).

**761—115.16(306A) Longitudinal installations on freeways.**

**115.16(1) Type of installation permitted.**

a. The department may permit the installation of an underground utility facility if, in addition to complying with other provisions of this chapter, the facility specifically complies with this rule.

b. Except as provided in this rule, no aboveground installations other than those needed to serve highway facilities are allowed.

**115.16(2) Prohibitions on longitudinal occupancy.**

a. A utility facility shall not be used for transmitting gases or liquids or for transmitting products that are flammable, corrosive, expansive, highly energized or unstable.

b. A utility facility shall not present a hazard to life, health or property if it fails to function properly, is severed or is otherwise damaged.

c. No direct service connection to adjacent properties is allowed.

d. No utility facility is allowed in or on a structure carrying a freeway roadway or ramp, except for freeway border bridges, as provided in subrule 115.12(5).

**115.16(3) Minimal maintenance.** Once installed, the utility facility shall require minimal maintenance.

**115.16(4) Location and depth.** The utility facility shall be located on uniform alignment, preferably within eight feet of the freeway right-of-way line, and at a location approved by the department.

a. See subrule 115.13(1) for minimum depth requirements.

b. Except for multiduct systems, borings and isolated locations as determined by the department, cable shall be installed by the plowing method.

c. Utility accesses and splice boxes may be placed below the existing ground line. The location and number of installations are subject to department approval.

**115.16(5) Identification signs, pedestals and repeater stations.**

a. The utility owner shall place identification signs within 12 inches of the right-of-way fence, at the line of sight, along the entire occupancy route. These signs shall identify the owner/operator's name, telephone number to contact in case of an emergency, and the type of buried utility.

(1) The signs shall be composed of an ultraviolet-resistant material.

(2) Each sign shall be no larger than 200 square inches.

(3) The interval between signs shall not exceed one-quarter mile in rural areas and 500 feet in urban areas, or as designated by the department.

(4) Additional signs shall be placed on each side of a public highway, road or street intersecting or crossing the freeway at points where the freeway right-of-way line intersects the public highway, road or street right-of-way line.

(5) The utility owner is responsible for installing and maintaining these identification signs.

b. Aboveground pedestals are permissible. Pedestals should be placed one foot from the right-of-way fence. The number of installations is subject to department approval.

c. Repeater stations are not allowed in the right-of-way.

**115.16(6) Metallic warning tape.** Metallic warning tape shall be installed a minimum of 12 inches below the existing grade and above the utility installation to facilitate locating the installation in the future.

**115.16(7) Engineering.** The utility owner shall retain the services of a licensed, professional engineer.

a. The engineer is responsible for overseeing continuous on-site inspection of the installation of the facility including all provisions pertaining to access to the work site and traffic control.

b. Upon completion of the project, the engineer shall certify to the department on the appropriate forms that the installation, traffic control, and access to the work site were accomplished in accordance with the permit.

c. Any change to the alignment as described in the original permit requires the prior approval of the department and the submission of as-built plans.

**115.16(8) Occupancy fee.** The utility owner shall pay to the department an annual fee for longitudinal occupancy of the freeway right-of-way. The initial fee is due before any construction work commences within the right-of-way.

a. Unless otherwise specified, the annual fee shall be as follows:

(1) When a multiduct system is required by the department: flat fee of \$14,500 per cable installation or \$7,250 per mile of cable, whichever is greater. These fees shall increase 3 percent per year after the base year of 2004.

(2) All other installations: flat fee of \$12,000 per cable installation or \$2,500 per mile of cable, whichever is greater. These fees shall increase 3 percent per year after the base year of 2004.

b. When the department requires the installation of a multiduct system, the department may enter into an agreement with the lead company for a discounted fee payment schedule to be in effect until the company has recovered all or an agreed upon portion of its cost of installing the system. Subsequent occupants of the multiduct system shall pay the full annual fee.

c. The department may negotiate an annual fee for occupancy dedicated solely to state government use.

**115.16(9) Performance bond.** The utility owner shall file a performance bond with the department prior to commencing work within the freeway right-of-way.

a. The bond shall be in the amount of \$100,000 per permit and shall guarantee prompt restoration of any damage caused during the installation of the utility facility.

b. The bond shall be in force for the duration of the construction. The department shall have the right to file a claim against the bond for two years thereafter.

**115.16(10) Insurance.**

a. The utility owner shall maintain the following insurance for bodily injury, death and property damage arising out of or in connection with the construction, maintenance and operation of the facility:

(1) General public liability insurance with limits of not less than \$500,000 for injury to or death of a single person, or not less than \$1,000,000 for any one accident, and not less than \$250,000 per accident for property damage.

(2) Comprehensive automobile liability insurance with limits of not less than \$500,000 for injury to or death of a single person, or not less than \$1,000,000 for any one accident, and not less than \$250,000 per accident for property damage.

(3) Excess liability coverage with limits of not less than \$5,000,000.

(4) Statutory workers' compensation coverage.

b. This insurance shall be in effect before the utility owner commences any work within the freeway right-of-way.

c. Coverage may be provided by blanket policies of insurance covering other property or risks.

d. The department shall be named as an additional insured party in the general public liability and excess liability insurance policies.

**115.16(11) Future adjustment.**

a. As a condition of the permit, the utility owner shall agree to waive all future rights to be reimbursed for adjustment costs incurred should maintenance or construction of the freeway system require adjustment of the utility facility.

b. Should adjustment of the utility facility be required, the department makes no assurance nor assumes any liability to the utility owner that the facility will again be allowed to occupy the freeway right-of-way.

**115.16(12) Term of permit.** The term of the permit shall not exceed 20 years. When the permit expires, the department may extend it in writing or renegotiate its terms.

**115.16(13) Utilities for highway facilities.** Longitudinal occupancy of utility facilities that service highway-related facilities are permissible upon such terms and conditions as the department may determine.

#### **761—115.17(306A) Nonfreeway primary highways.**

**115.17(1)** Clear zone requirements and aboveground obstructions. Subrule 115.5(5) applies. In addition:

a. In urban areas with rural-type roadways and speed limits of 45 miles per hour or lower, a permanent, aboveground obstruction shall be located at least 15 feet from the edge of the paved traveled way or beyond the highway foreslope, whichever location is farther from the traveled way.

b. On urban-type roadways, the face of a permanent, aboveground obstruction shall be located no closer than ten feet from the back of the curb. In areas with parking or auxiliary lanes, aboveground obstructions shall be located no closer than two feet behind the back of the curb or a minimum of ten feet from the edge of the traveled way, whichever location is farther from the traveled way.

c. In rural areas with rural-type roadways, poles, guys and other supporting structures and related aboveground facilities should be located as near to the right-of-way line as practical.

(1) These aboveground obstructions shall be located in an area beyond the clear zone or the highway foreslope, whichever area locates the obstruction a greater distance from the edge of the traveled way, right-of-way width permitting.

(2) In individual cases, the department may require the use of self-supporting poles or towers, double arming and insulators, breakaway devices and dead-end construction.

d. In suburban areas with rural-type roadways and speed limits of 45 miles per hour or lower, utility poles shall be located at least 15 feet from the edge of the paved traveled way or beyond the highway foreslope, whichever location is farther from the traveled way. The preferred location is near the right-of-way line.

*e.* Poles, guys, anchors and other appurtenances shall not be located in ditches, at drainage structure openings or on roadway shoulders. All poles, guys, anchors and other appurtenances shall be located to minimize interference with the maintenance operations of the department.

*f.* The district representative may approve the adjustment of minimum setback distances for poles and other appurtenances that have a breakaway design.

**115.17(2)** Reserved.

**761—115.18(306A) Longitudinal installations on nonfreeway primary highways.**

**115.18(1)** *Location.* Longitudinal utility facility installations should be located on uniform alignment as near as practical to the right-of-way line so as to provide a safe environment for traffic operations and to preserve space for future highway improvements and other utility installations.

**115.18(2)** *Underground installations.*

*a.* No carrier of flammable, corrosive, expansive or unstable material shall be placed longitudinally within the right-of-way of a nonfreeway primary highway. Exceptions:

(1) A natural gas line with an operating pressure that is no greater than 150 pounds per square inch is permissible.

(2) The department may permit the placement of a natural gas line with an operating pressure that is greater than 150 pounds per square inch only if a suitable alternate location cannot be found.

*b.* On rural-type roadways, utility facilities shall be located in an area beyond the highway foreslope, right-of-way width permitting, except at locations where this is not acceptable, such as deep ravines or ditches.

*c.* On urban-type roadways, utility facilities should be located as near to the right-of-way line as practical and preferably not within the traveled way. A utility access placed within the right-of-way shall not protrude above the surrounding surface.

*d.* In general, utility facilities are not allowed in the median. However, in special cases the district representative may approve such an installation.

**761—115.19(306A) Maintenance and emergency work.**

**115.19(1)** *Maintenance responsibilities.* The owner of a utility facility is responsible for its maintenance. The owner shall:

*a.* Maintain the facility in a good state of repair in accordance with applicable federal, state and local statutes, ordinances and regulatory standards.

*b.* Replace and stabilize all earth cover and vegetation where they have eroded over an underground utility facility when the erosion is due to or caused by the placement or existence of the facility.

*c.* Give the department's district representative 48 hours' prior notice of its intent to perform predictable routine maintenance within the right-of-way. Exception: Notice is not required if the predictable routine maintenance is for a service connection located beyond the clear zone of a nonfreeway primary highway.

**115.19(2)** *Utility emergency work.*

*a.* Access to the worksite is permissible from the freeway roadways and ramps when an emergency exists.

*b.* The utility owner shall take all necessary, appropriate and reasonable measures to protect the safety of the traveling public and cooperate fully with the state highway patrol and the department in completing the emergency work.

*c.* The utility owner shall notify the department of the emergency as soon as practical, describing the steps being taken to protect the traveling public, the extent of the emergency, and the steps being taken to address the emergency.

*d.* If the nature of the emergency is such that it interferes with the free movement of traffic, the utility owner shall immediately notify the state highway patrol and the department.

*e.* When an emergency occurs on the interstate system, the department shall notify the FHWA as soon as practical, describing the steps being taken to protect the traveling public and the steps being taken to address the emergency.

**115.19(3)** *Department emergency work.* There will be times when the department performs highway-related emergency work. Examples include but are not limited to stop sign replacement, handling hazardous material spills, and addressing natural disasters and acts of terrorism. If utility facilities are affected, the department shall as soon as practical notify the utility owner of the emergency condition and what steps are necessary to protect the utility facility.

**761—115.20(306A) Abandonment or removal of utility facilities.**

**115.20(1)** *Notice to department.* Within 90 days after the abandonment or removal of all or a portion of an existing utility facility that occupies the primary highway right-of-way, the utility owner shall submit a written notice of abandonment or removal to the department. The notice shall include:

- a. Type of facility.
  - b. Location of the utility facility by route, county, section, township, range, milepost and highway stationing, where these references exist.
  - c. Name of the original utility owner if different than the current owner.
  - d. Original utility permit number and date of approval, if known.
- 115.20(2)** Reserved.

**761—115.21 to 115.24** Reserved.

**761—115.25(306A) Utility facility adjustments for highway improvement projects.** Rules 761—115.26(306A) to 761—115.30(306A) establish administrative procedures for utility facility adjustments made necessary by state highway improvement projects. The purpose of these procedures is to adjust utility facilities with minimal delays or added expense. Rules 761—115.26(306A) to 761—115.30(306A) apply to all state highway improvement projects with the following exceptions:

1. Projects the department develops on an accelerated schedule.
2. Projects with no anticipated utility adjustments.

**115.25(1)** Should the department be responsible for the cost of a utility facility adjustment required for highway work, the department shall not pay for any betterment that results in an increase in the capacity of the facility or for any other adjustment not required by highway construction. The department is entitled to receive credit for the accrued depreciation on replaced facilities and the salvage value of any materials or parts salvaged and retained or sold by the utility owner.

**115.25(2)** Adjustment costs for which the department is responsible shall be paid on a cost reimbursement basis.

**115.25(3)** If adjustment of an existing utility facility occupying the right-of-way is required due to highway construction, the utility owner shall adjust the facility without cost to the state and, whenever possible, in advance of the highway work.

**761—115.26(306A) Notice of project.**

**115.26(1)** *Determining affected utilities.* The department shall make a reasonable effort to determine what utility facilities are located within the project limits of a state highway improvement project by researching permit files, through field investigations or contacts with one-call locating services, and through contacts with local government units.

**115.26(2)** *Notifying utilities.* The department shall identify by name the owner of each known utility facility that is located within the project limits. The department shall send to each utility owner a notice of the improvement project, including the route number of the highway, the geographical limits of the project and a general description of the highway work to be done.

**115.26(3)** *Responding to notice.* The utility owner shall:

- a. Within seven calendar days after the date of the notice, reply to the department, acknowledging receipt of the notice.
- b. Within 90 calendar days after the date of the notice, provide to the department information about its utility facilities that are in the vicinity of the improvement project, including the name of any company that has utility facilities which coexist with the utility owner's facilities. The utility owner shall reply regardless of whether or not it has facilities in the project's vicinity.

**761—115.27(306A) First plan submission, preliminary work plan and agreement.**

**115.27(1)** *First plan.* The department shall submit its first plan to the owner of each known utility facility within the project limits. The first plan shall contain information the owner needs in order to design and lay out the adjustment of its utility facilities, including the placement of adjusted or additional facilities, within the project limits.

**115.27(2)** *Preliminary work plan.* Within 90 calendar days after the date the department submits its first plan, the utility owner shall provide to the department a preliminary work plan.

a. The preliminary work plan shall include the following:

- (1) A narrative description of what work the utility owner will do.
- (2) A drawing showing the present and proposed locations of the utility owner's facilities in relation to the highway plan.
- (3) Whether the work is dependent on work by another utility owner.
- (4) Whether the work can be done prior to highway construction or must be coordinated with the highway contractor.

(5) The number of working days required to complete the work.

(6) A list of permits and approvals the utility owner is required to obtain from governmental agencies and railroad companies for the work, and the expected time schedule to obtain them.

*b.* If the utility adjustment work is reimbursable, the utility owner shall submit with the preliminary work plan the following:

(1) Copies of documents verifying real estate interests.

(2) A detailed cost estimate for the adjustment, including appropriate credits for betterments or salvage.

**115.27(3)** *Department review of preliminary work plan.* The department shall review each utility owner's preliminary work plan to ensure compatibility with utility accommodation permit requirements, the plans for the highway improvement project, and the construction schedule.

**115.27(4)** *Conflict between preliminary work plans.* When requested by the utility owners or when the department determines there is potential for conflict between preliminary work plans, the department shall schedule a coordination meeting. All affected utility owners shall attend the meeting to coordinate their work plans. The department may allow a utility owner an additional 30 calendar days to submit its preliminary work plan if coordination is required with other utility owners.

**115.27(5)** *Acceptance of preliminary work plan.* The department shall notify the utility owner of the department's acceptance of the utility owner's preliminary work plan.

*a.* If the preliminary work plan is not acceptable to the department, the department shall notify the utility owner that the plan is not acceptable and provide a detailed explanation of the problem.

*b.* The utility owner shall submit a revised preliminary work plan to the department within 30 calendar days after its receipt of notice from the department that the plan was not acceptable.

*c.* The department shall review the revised preliminary work plan. If the work plan is acceptable, the department shall notify the utility owner of the department's acceptance of the plan.

*d.* If the work plan is still not acceptable, the process set out in 115.27(5) "a" to "c" shall be repeated.

**115.27(6)** *Agreement.*

*a.* The department shall enter into an agreement with the utility owner if the adjustment is eligible for reimbursement.

*b.* The agreement by itself does not constitute a permit nor does it grant permission to occupy the primary highway right-of-way. The utility owner is responsible for obtaining a utility accommodation permit prior to commencing work within the right-of-way. The agreement will then be attached to and become part of the permit.

#### **761—115.28(306A) Second plan submission, final work plan and permit application.**

**115.28(1)** *Second plan.* After the final public information meeting, the department shall submit its second plan to the owner of each known utility facility within the project limits. The second plan shall show any additional plan information or design changes the owner needs in order to complete its design and layout for the adjustment. The department shall clearly identify to the utility owner the differences between the first and second plans.

**115.28(2)** *Final work plan.* Within 60 calendar days after the date the department submits the second plan, the utility owner shall provide to the department a final work plan.

*a.* The final work plan shall include the anticipated starting date for the utility owner's work within the primary highway right-of-way.

*b.* A completed application for a utility accommodation permit must accompany the final work plan for work within the primary highway right-of-way. The work plan by itself does not constitute a permit nor does it grant permission to occupy the primary highway right-of-way.

*c.* When requested by the utility owner, the department may allow additional time to complete the final work plan if the second plan requires extensive modifications to the preliminary work plan.

*d.* If there are no changes to the preliminary work plan, the utility owner need only notify the department that the preliminary work plan is now the final work plan.

**115.28(3)** *Department review of final work plan.* The department shall review each utility owner's final work plan to ensure compatibility with utility accommodation permit requirements, the plans for the highway improvement project, and the construction schedule.

**115.28(4)** *Acceptance of final work plan.* The department shall notify the utility owner of the department's acceptance of the utility owner's final work plan.

*a.* If the final work plan is not acceptable to the department, the department shall notify the utility owner that the plan is not acceptable and provide a detailed explanation of the problem.

*b.* The utility owner shall submit a revised final work plan to the department within 30 calendar days after its receipt of notice from the department that the plan was not acceptable.

c. The department shall review the revised final work plan. If the work plan is acceptable, the department shall notify the utility owner of the department's acceptance of the plan.

d. If the work plan is still not acceptable, the process set out in 115.28(4) "a" to "c" shall be repeated.

#### **761—115.29(306A) Notice of work.**

**115.29(1)** *Notice of receipt of permits and approvals.* The utility owner shall notify the department within 14 calendar days after the utility owner has received all required permits and approvals from government agencies and railroad companies.

**115.29(2)** *Notice to utility owner to begin work.*

a. The department shall send a notice to proceed to the utility owner not less than 30 calendar days before the utility owner is required to begin the work provided for in its work plan.

b. If the utility owner's work plan is dependent upon work by the highway contractor, the contractor shall provide the department and the utility owner a good faith notice 14 calendar days before the contractor's work is expected to be complete and ready for the utility owner to begin its work. The highway contractor shall follow up with a confirmation notice to the department and the utility owner not less than three working days before the contractor's work will be complete and ready for the utility owner to begin its work.

**115.29(3)** *Notice to department of commencement and completion of work.* The utility owner shall give the department 48 hours' prior notice, excluding weekends and holidays, of its intent to start utility adjustment work within the project limits. The utility owner shall also notify the department immediately upon completion of the work.

#### **761—115.30(306A) Miscellaneous adjustment provisions.**

**115.30(1)** *Work plan compliance.* The utility owner shall complete its utility adjustment work within the time frame of the work plan accepted by the department. Upon completion of the work, the utility owner shall certify to the department that the adjustment of its facilities is in accordance with the accepted work plan.

**115.30(2)** *Project changes prior to the letting.* If, prior to the letting date of the highway improvement project, changes to the project result in the need for additional utility adjustment work, the department shall furnish a revised project plan to each affected utility owner. The department shall clearly identify to the utility owner those portions of the project that have been revised. Within 60 calendar days after the date the department submits the revised project plan, the utility owner shall provide to the department a revised work plan.

**115.30(3)** *Project changes after the letting.* If, after the letting date of the highway improvement project, changes to the project result in the need for additional utility adjustment work, the department shall notify each affected utility owner. The department and the owner shall agree on a revised work plan.

**115.30(4)** *Work plan changes.* If a utility owner needs to change its work plan after its adjustment work begins, the utility owner shall notify the department. Once the department approves a modified work plan, the utility owner may make the necessary changes and perform the work.

**115.30(5)** *Cost allocation.*

a. If the department requires the adjustment of a utility facility that was originally determined, per the notice and work plan processes, to not need adjustment:

(1) The utility owner shall bear the cost of the adjustment if the work is otherwise not reimbursable.

(2) The department shall bear the reasonable cost of the adjustment if the work is otherwise reimbursable.

b. If the department requires additional adjustment to a utility facility after the facility has been adjusted in accordance with a work plan accepted by the department, the department shall bear the reasonable cost of the additional work. This applies to all utility facilities, whether the original adjustment work was reimbursable or not reimbursable.

c. The utility owner shall bear the cost of additional adjustment work performed after its facilities have been adjusted in accordance with a work plan accepted by the department if the additional work is due to the utility owner's error.

**115.30(6)** *Failure to provide a work plan or to adjust utility facilities.* If a utility owner fails to provide a work plan, fails to comply with the accepted work plan, or fails to complete the adjustment of its facilities, and its failure to perform results in a delay to the highway project or causes damages to be incurred by the department or the department's highway contractor, the utility owner is liable for all costs and damages incurred as a result of its failure to perform. The department may withhold approval of permits for failure to comply with the requirements of these rules.

These rules are intended to implement Iowa Code chapters 306A and 319, section 314.20, and sections 320.4 to 320.8.

[Filed 10/2/85, Notice 8/14/85—published 10/23/85, effective 11/27/85]

[Filed 5/11/87, Notice 3/11/87—published 6/3/87, effective 7/8/87]

[Filed 11/29/89, Notice 10/18/89—published 12/27/89, effective 1/31/90]

[Filed 3/11/92, Notice 2/5/92—published 4/1/92, effective 5/6/92]

[Filed 3/7/01, Notice 1/10/01—published 4/4/01, effective 5/9/01]

[Filed 9/16/03, Notice 8/6/03—published 10/15/03, effective 11/19/03]

[Filed 9/14/05, Notice 8/3/05—published 10/12/05, effective 11/16/05]

[Filed ARC 9873B (Notice ARC 9781B, IAB 10/5/11), IAB 11/30/11, effective 1/4/12]

[Filed ARC 2889C (Notice ARC 2779C, IAB 10/26/16), IAB 1/4/17, effective 2/8/17]



CHAPTER 116  
JUNKYARD CONTROL

[Prior to 6/3/87, Transportation Department[820]—(06,F)Ch 7]

**761—116.1(306C) Definitions.** The definitions in Iowa Code section 306C.1 apply to this chapter. In addition:

*“Abandoned or discontinued junkyard”* means an accumulation of junk which would be a junkyard except that it has not been maintained, operated or used as an establishment or place of business for storing, keeping, buying or selling junk for the past 12 months. The owner or operator of a yard that otherwise would be an abandoned or discontinued junkyard may continue to qualify the yard as a junkyard by providing proof of income or loss through a copy of federal, state or local income tax return or proof of the purchase or acquisition of new junk or sale or disposal of junk as substantiated by receipts, canceled checks, or other acceptable evidence of value exchanged.

*“Adjacent area”* means an area which is contiguous to and within 1,000 feet of the nearest edge of the right-of-way of any highway on the national highway system.

*“Automobile graveyard”* means any establishment which is maintained, used, or operated for storing, keeping, buying, or selling ten or more wrecked, scrapped, ruined, dismantled or inoperative motor vehicles, but does not include any location where motor vehicle bodies are placed along stream banks for purposes of bank stabilization and soil erosion control, if such placement conforms with guidelines established by the department of natural resources.

*“Industrial activities”* means activities that are permitted only in industrial zones, or in less restrictive zones by the nearest zoning authority within the state, or prohibited by the authority but generally recognized as industrial by other zoning authorities within the state, except that none of the following are considered to be industrial activities:

1. Outdoor advertising structures.
2. Agricultural, forestry, ranching, grazing, farming and related activities including, but not limited to, wayside fresh produce stands.
3. Activities normally and regularly in operation less than three months of the year.
4. Transient or temporary activities.
5. Activities not visible from the main traveled way.
6. Activities more than 300 feet from the nearest edge of the main traveled way within the corporate limits of cities.
7. Activities more than 1,000 feet from the nearest edge of the main traveled way outside the corporate limits of cities.
8. Activities conducted in a building principally used as a residence.
9. Railroad tracks, minor sidings, and passenger depots.
10. Junkyards.

*“Industrial zone”* means a zone established by zoning authorities as being most appropriate for industry or manufacturing. A zone which simply permits certain industrial activities as an incident to the primary land use designation is not considered to be an industrial zone.

*“Inoperative motor vehicle”* means any of the following:

1. A motor vehicle that does not have a valid title.
2. A motor vehicle that does not have a current registration, unless the motor vehicle is in the inventory of a motor vehicle dealer licensed under Iowa Code chapter 322.
3. A motor vehicle with one or more of the following items missing or in need of substantial repair: windshield, driver’s seat, steering wheel or steering system, battery, ignition system, fuel tank or fuel supply system, engine, transmission, drive shaft, differential, axle, suspension system, brake system, or frame.
4. A motor vehicle that is not immediately capable of legal operation on a public road or street.

However, any one of the following by itself does not render a motor vehicle inoperative: a battery that can be recharged, one tire and wheel missing or in need of repair, or lack of fuel.

The burden of proving that a motor vehicle is not inoperative rests with the person or persons in possession of that vehicle. However, if the temperature is below 32 degrees Fahrenheit, no person is required to demonstrate that the engine of a motor vehicle will start.

*“Main traveled way”* means the portion of the roadway for movement of vehicles on which through traffic is carried, exclusive of shoulders and auxiliary lanes. In the case of a divided highway, the main traveled way includes each of the separated roadways for traffic moving in opposite directions, exclusive of shoulders, auxiliary lanes, frontage roads, turning roadways, and parking areas.

*“Nonconforming junkyard”* means a junkyard which continues to be legally maintained, but which does not meet any of the exceptions in subrule 116.2(2), and which was lawfully established:

1. Prior to July 1, 1972, and is located within the adjacent area of an interstate highway.

2. Prior to May 6, 2015, and is located within the adjacent area of a noninterstate highway on the national highway system.

3. Prior to the effective date of a zoning change which caused nonconformity with these rules.
4. Prior to the departure or closure of an industrial activity which caused nonconformity with these rules.
5. Prior to the establishment of a highway as part of the national highway system.

“*Right-of-way*” means land area dedicated to public use for the highway and its maintenance, and includes land acquired in fee simple or by permanent easement for highway purposes, but does not include temporary easements or rights for supplementary highway appurtenances.

“*Unzoned industrial area*” means land occupied by a regularly used building, parking lot, storage area or processing area of an industrial activity, and land within 1,000 feet thereof which is:

1. Located on the same side of the highway as the activity,
2. Not predominantly used for residential or commercial purposes, and
3. Not zoned by state or local law, regulation or ordinance.

“*Visible*” means capable of being seen without visual aid by a person of normal visual acuity.

This rule is intended to implement Iowa Code sections 306C.1 to 306C.9.

[ARC 1923C, IAB 4/1/15, effective 5/6/15]

### **761—116.2(306C) Junkyards prohibited—exceptions.**

#### **116.2(1) Prohibitions.**

a. After July 1, 1972, a person shall not establish, operate, or maintain a junkyard any portion of which is within the adjacent area.

b. After May 6, 2015, a person shall not establish, operate, or maintain a junkyard any portion of which is within the adjacent area of a highway on the national highway system.

**116.2(2) Exceptions.** Junkyards that are prohibited in subrule 116.2(1) shall be allowed if they meet one or more of the following criteria:

- a. The junkyard is screened by natural objects, plantings, fences, or other appropriate means.
- b. The junkyard is located within an industrial zone.
- c. The junkyard is located within an unzoned industrial area.
- d. The junkyard is not visible from the main traveled portion of the highway.

This rule is intended to implement Iowa Code section 306C.2.

[ARC 1923C, IAB 4/1/15, effective 5/6/15]

### **761—116.3(306C) Screening or removal.**

**116.3(1) Nonconforming junkyards.** Nonconforming junkyards which do not meet any of the exceptions in subrule 116.2(2) shall be screened by the department, if feasible, or removed by the department. However, this requirement is conditioned on the availability of participating federal funds for this purpose and a determination by the department that such funds are adequate for this purpose. Prior to the date of the installation of screening or of removal, a nonconforming junkyard may continue in existence unscreened, provided the portion visible to the main traveled way is not increased in height, width, or length. This subrule shall not abrogate any other more restrictive state or local law or regulation which governs the screening, licensing, operation or existence of the junkyard.

**116.3(2) Owner requirements.** The following junkyards shall be screened or removed by the owner at no expense to the department:

a. Junkyards established after July 1, 1972, and located within the adjacent area of an interstate highway, but which do not meet any of the exceptions in subrule 116.2(2).

b. Junkyards established after May 6, 2015, and located within the adjacent area of a noninterstate highway on the national highway system, but which do not meet any of the exceptions in subrule 116.2(2).

c. Nonconforming junkyards of which portions visible to the main traveled way have increased in height, width, or length since the date the junkyard became nonconforming.

This rule is intended to implement Iowa Code section 306C.3.

[ARC 1923C, IAB 4/1/15, effective 5/6/15]

**761—116.4(306C) Acquisition.** When the department determines that it is in the best interests of the state, it may acquire by gift, purchase, exchange, or condemnation, as provided by law, the property or rights or interests in property as may be necessary to provide adequate screening for junkyards. When the department determines that screening of a junkyard will not be economically feasible, the department may acquire the property or rights or interests in property as may be necessary to secure the relocation, removal, or disposal of the junkyard and shall pay the cost of the relocation, removal, or disposal. However, no plan for relocation, removal, or disposal which qualifies

for federal participation shall be undertaken unless the department has received notification from the federal government that the federal share to be paid is immediately available for that purpose.

This rule is intended to implement Iowa Code section 306C.5.

**761—116.5(306C) Screening.** Screening for each individual junkyard required to be screened shall meet the standards of these rules. Where the owner is required to screen, the owner shall submit a screening plan which shall be approved by the department. Screening plans shall integrate the screen with the natural surroundings and shall consider and make provisions to ensure reasonable access to the screen for purposes of maintaining the screens required by these rules.

**116.5(1) Purpose.** Screening shall be designed to eliminate the visual impact of the junkyard contents by obscuring it from view from the main traveled portion of the highway.

**116.5(2) Type.** Materials for use in screening and junkyards shall generally consist of natural objects, plantings, fences, or other appropriate means such as storage sheds, buildings and other similar elements.

*a.* Natural objects shall be earthen berms, rock formations, wooded areas, or other similar elements.

*b.* Plantings shall be shrubs and trees of such types as to provide year-round obscurement commensurate with local site conditions. All plant material used for screening shall be of a size and quantity to provide obscurement.

*c.* Screens shall be made of wood, metal or other materials commonly used in the building trade, and shall be of a height and type necessary to provide obscurement. Screens shall be designed to withstand a minimum wind load of 20 pounds per square foot and shall be of a permanent nature. All materials used for finishing screens shall be a nonreflective material which will blend with the natural surroundings. Screening shall not be placed so that either the screen or the maintenance of the screen will create or contribute to the creation of a safety hazard or endanger public safety or will interfere with the public's use or the department's maintenance of the highway.

**116.5(3) Maintenance.** The owner or operator of a junkyard shall maintain the screening in a condition equal to the original installation of the screening. Maintenance shall include, but not be limited to, the following items:

*a.* Replacement of plant material which is dead or has been damaged so that it no longer serves the intended purpose of screening the junkyard.

*b.* Screen maintenance shall include the renewal of the surface treatment with stains, paints, or other appropriate material as specified in subrule 116.5(2) when needed and the replacement of panels, sections, members, or support structures of the screening when needed.

This rule is intended to implement Iowa Code section 306C.4.

**761—116.6(306C) Nuisance—injunction.** Any junkyard operated or maintained or which is altered, changed or enlarged in violation of these rules and the Iowa Code shall be considered a public nuisance. If, after written notice by certified mail to the landowner and the owner of the junkyard of any such violation, the owner or operator fails or refuses to comply with the terms of the notice, the department may apply for an injunction to abate the nuisance.

This rule is intended to implement Iowa Code section 306C.6.

**761—116.7(17A) Hearings and appeals.** A person who is aggrieved by a decision of the department and who is entitled to a hearing may contest the decision pursuant to 761—Chapter 13.

This rule is intended to implement Iowa Code chapter 17A.

**761—116.8(306C) Contact information.** Inquiries regarding this chapter shall be directed to the Advertising Management Section, Office of Traffic and Safety, Department of Transportation, 800 Lincoln Way, Ames, Iowa, 50010.

This rule is intended to implement Iowa Code sections 306C.1 to 306C.9.

[Filed 1/20/78, Notice 11/16/77—published 2/8/78, effective 3/15/78]

[Filed 2/7/86, Notice 12/18/85—published 2/26/86, effective 4/2/86]

[Filed 5/11/87, Notice 3/11/87—published 6/3/87, effective 7/8/87]

[Filed 11/7/02, Notice 9/4/02—published 11/27/02, effective 1/1/03]

[Filed 7/13/04, Notice 5/26/04—published 8/4/04, effective 9/8/04]

[Filed ARC 1923C (Notice ARC 1832C, IAB 1/21/15), IAB 4/1/15, effective 5/6/15]



CHAPTER 117  
OUTDOOR ADVERTISING

[Prior to 6/3/87, Transportation Department[820]—(06,O) Ch 5]

**761—117.1(306B,306C) Definitions.** The definitions in Iowa Code section 306C.10 are adopted. In addition:

*“Abandoned sign”* means an advertising device for which the owner has failed to timely apply for the required outdoor advertising permit(s) or has failed to timely pay the required fee(s).

*“Area zoned and used for commercial or industrial purposes”* means an area zoned for commercial or industrial purposes in accordance with Iowa Code chapter 414, in the case of city zoning, or in accordance with Iowa Code chapter 335, in the case of county zoning, in which one or more commercial or industrial activities, as defined under the city or county zoning ordinance, are located.

*“Billboard control Act”* means Iowa Code chapter 306C, division II.

*“Bonus Act”* means Iowa Code chapter 306B.

*“Daylight area”* means a triangular area formed by a line connecting two points each back (50 feet in city, 100 feet in unincorporated area) from the point where the right-of-way lines of the main traveled way and an intersecting street meet or would meet if extended.

*“Destroyed”* means that at least 60 percent of the supports are broken, if wooden, or broken, bent or twisted, if metal, such that normal repair practices would call for the replacement of the damaged supports.

*“Face”* means that part of an advertising device that is devoted to the display of advertising and that is visible to traffic proceeding in any one direction.

*“Interchange”* means the entire area constructed for a junction of two or more public streets or highways by a system of separate levels that permit traffic to pass from one level to another without the crossing of traffic streams. This includes all acceleration and deceleration lanes constructed to accommodate this movement of traffic.

*“Lease”* means an agreement, oral or written, by which possession or use of land or interests therein are given by the owner or other person to another person for a specified purpose.

*“LED display”* means a face, as defined herein, displaying a message that is formed by light emitting diodes and that is changed by an electronic process. An LED display is a single face.

*“Modification”* means any addition to or change in dimensions, lighting, structure or advertising face, except as incidental to the customary maintenance of an advertising device.

1. A change in the number or type of support posts is a modification. A change in dimensions is a modification. However, the addition of extensions or cutouts, including forward projecting, is not a modification if the extensions or cutouts are added for a period of 90 days or less and if they are illuminated only by existing sign lighting and do not contain internal lighting.

2. A lawful change in advertising message is not a modification. The use of a vinyl overlay or wrap on either a poster panel or paint unit is a change in advertising message, not a modification.

3. On an advertising device that conforms to all current requirements, the replacement of one metal-framed face with another metal-framed face of the same size, using dissimilar component parts or assembly methods, or both, is not a modification.

4. The addition of LED display capabilities to an advertising device is a modification.

5. The elimination of trim surrounding the area used for advertising copy is not a modification, provided the advertising copy retains the same dimensions as the original advertising copy.

*“Nonconforming sign”* means an advertising device that was lawfully erected and continues to be lawfully maintained, but that does not comply with current requirements due to changed conditions, such as a change in zoning, establishment of a new highway, or a similar change that affects compliance.

*“Regularly used”* means open for business and staffed by an owner or employee for at least 20 hours per week, on property assessed as commercial or industrial by the jurisdiction having authority; the hours of operation must be visibly posted on the premises. The department may delay action on the permit application for up to 180 days from the date of the application in order to conduct periodic checks on the site as necessary to determine whether the purported commercial or industrial activity meets this definition. A rental storage business is excepted from the staffing requirement if it has 24-hour access for customers and a minimum of 50 units, each occupying at least 50 square feet, individually separated, and enclosed by walls.

*“Scenic area”* means any area of particular scenic beauty or historical significance, as determined by the federal, state or local officials having jurisdiction of the area. It includes real property interests that have been acquired for the restoration, preservation and enhancement of scenic beauty.

“*Tri-face device*” means an advertising device with three singular faces attached to one common structure in a triangular configuration. The maximum area of any face is 750 square feet. The inside angle formed by any two faces may not exceed 60 degrees.

“*Tri-vision device*” means an advertising device that has an advertising face with a mechanical device that allows three advertising messages to be alternately visible to traffic proceeding in any one direction. Each message is attached to individual vertical or horizontal louvers, which are mechanically rotated to change the message.

“*Widening*” means the point at which it is detectable that a deceleration or exit ramp is beginning to form alongside the main traveled way, or an acceleration or merging ramp has tapered to a close alongside the main traveled way. In the case where an entrance ramp becomes an auxiliary lane and the auxiliary lane becomes an exit ramp at the adjacent interchange, the widening shall be the point at which a deceleration ramp completely separates from the main traveled way as evidenced by the inside lane marking of such ramp, or an acceleration ramp joins with the main traveled way as evidenced by the inside lane marking of the ramp intersecting with the outside lane marking of the main traveled way.

[ARC 2645C, IAB 8/3/16, effective 9/7/16; ARC 4984C, IAB 3/11/20, effective 4/15/20; ARC 6020C, IAB 11/3/21, effective 12/8/21]

### 761—117.2(306B,306C) General provisions.

**117.2(1) Scope.** This chapter of rules pertains to all advertising devices which are visible from the main traveled way of any primary highway, with the following exceptions:

a. Within incorporated areas, this chapter does not apply to advertising devices which are beyond 660 feet from the nearest edge of the right-of-way.

b. This chapter does not apply to official traffic control devices, logo signing or tourist-oriented directional signing.

**117.2(2) Rebuttable presumption.** The department may regulate signs as advertising devices except when sufficient documentation from persons reasonably identified as potential payors or receivers of remuneration is available to the department showing or certifying that remuneration does not exist.

**117.2(3) Contact information.** Inquiries, requests for forms, and applications regarding this chapter shall be directed to the Advertising Management Section, Traffic and Safety Bureau, Department of Transportation, 800 Lincoln Way, Ames, Iowa 50010.

**117.2(4) Unauthorized signs, signals, or markings.** Any sign, signal, marking or device prohibited by Iowa Code section 321.259 is a public nuisance and shall be removed by the department if it is within the department’s jurisdiction.

**117.2(5) Advertising devices obstructing the view of a highway or railway.** Any advertising device that obstructs the view of any portion of a public highway or railway track in violation of Iowa Code section 318.11(2) or 657.2(7) is a public nuisance, which shall be abated as provided in Iowa Code chapter 657.

**117.2(6) Advertising devices within the right-of-way.** Any advertising device placed or erected within the right-of-way of any primary highway in violation of Iowa Code chapter 318 is subject to removal in the manner specified in Iowa Code chapter 318.

**117.2(7) Advertising devices permitted under the private directional sign program between May 26, 1983, and July 1, 2021.**

a. Any advertising device permitted as a private directional sign by the department between May 26, 1983, and July 1, 2021, may continue to exist, even if nonconforming to this chapter, with the following conditions:

- (1) The permit is renewed each year by payment of a \$15 fee on or before July 1.
- (2) The permit may not be transferred to an entity representing a different activity or site.
- (3) The advertising device is not modified or destroyed.
- (4) The advertising device is properly maintained with legible copy.
- (5) The design or display of the advertising device does not violate any federal or state laws or regulations.

b. Advertising devices which fail to meet any of the conditions in this subrule shall be subject to removal as provided for in rule 761—117.8(306B,306C).

[ARC 2645C, IAB 8/3/16, effective 9/7/16; ARC 4984C, IAB 3/11/20, effective 4/15/20; ARC 6020C, IAB 11/3/21, effective 12/8/21]

**761—117.3(306B,306C,306D) General criteria.** The department shall control the erection and maintenance of advertising devices, subject to the provisions of these rules, in accord with the following criteria:

**117.3(1) Prohibition.** Advertising devices shall not be erected, maintained or illuminated unless they comply with the following:

- a. No advertising device shall attempt or appear to attempt to direct the movement of traffic.

b. No advertising device shall interfere with, imitate or resemble any sign, signal or device erected by the department within the right-of-way of any primary highway.

c. No advertising device subject to the more restrictive controls of the bonus Act shall move or have any animated or moving parts.

d. No advertising device shall be erected or maintained upon trees, painted or drawn upon rocks or other natural features.

e. No advertising device shall include any flashing, intermittent or moving light or lights except an LED display, provided:

(1) Each change of message is accomplished in one second or less.

(2) Each message remains in a fixed position for at least eight seconds.

(3) No traveling messages (e.g., moving messages, animated messages, full-motion video, scrolling text messages) or segmented messages are presented.

f. No lighting shall be used in any way in connection with any advertising device unless it is so effectively shielded as to prevent beams or rays of light from being directed at any portion of the main traveled way of any highway, or is of such low intensity or brilliance as to not cause glare or to impair the vision of the driver of any motor vehicle, or to otherwise interfere with any driver's operation of a motor vehicle. This paragraph does not prohibit an LED display provided the light intensity presented does not exceed that allowed for other illuminated displays.

g. Rescinded 11/3/21, effective 12/8/21.

h. No advertising device shall be in a state of disrepair or illegible for a period of time exceeding 90 days.

i. Advertising devices shall be securely affixed to a substantial structure.

j. No advertising device subject to the more restrictive controls of the bonus Act shall advertise activities which are illegal under federal or state laws in effect at the location of those activities or at the location of the sign.

k. An advertising device shall comply with all applicable state and local laws, regulations and ordinances, including but not limited to zoning, building and sign codes as locally interpreted and applied and enforced, which may be stricter than this chapter.

l. No advertising device may be erected within the adjacent area of any primary highway that has been designated a scenic highway or scenic byway if the advertising device will be visible from the highway. However, if the advertising device was in existence at the time of the designation, subsequent permitting may occur in accordance with Iowa Code section 306C.18.

m. An advertising device shall not be constructed or reconstructed beyond the adjacent area in unincorporated areas of the state if the advertising device is visible from the main traveled way of any primary highway.

**117.3(2) Measurements of distance.** Distance from the edge of a right-of-way shall be measured horizontally along a line normal or perpendicular to the centerline of the highway. All other measurements of distance shall be measured horizontally between points on a line parallel to the highway centerline.

**117.3(3) Measurement of area.** The area of an advertising device shall be measured by the smallest square, rectangle, triangle, circle or combination thereof which will encompass the entire display area including border and trim, but excluding temporary cutouts and extensions, base, apron, support, and other structural members.

**117.3(4) Zoning exclusions.**

a. A zone in which limited commercial or industrial activities are permitted incidental to other primary land uses is not a commercial or industrial zone for advertising control purposes.

b. Action which is not a part of comprehensive zoning in accordance with Iowa Code chapter 335 or Iowa Code chapter 414 is not a commercial or industrial zone for advertising control purposes.

c. Action taken primarily to permit advertising devices is not a commercial or industrial zone for advertising control purposes.

[ARC 2645C, IAB 8/3/16, effective 9/7/16; ARC 4984C, IAB 3/11/20, effective 4/15/20; ARC 6020C, IAB 11/3/21, effective 12/8/21]

**761—117.4(306B,306C) Interstate special provisions for on-premises signs.** Rescinded ARC 6020C, IAB 11/3/21, effective 12/8/21.

**761—117.5(306B,306C) Location, size and spacing requirements.**

**117.5(1) Advertising devices lawfully in existence prior to July 1, 1972.**

a. An advertising device that was lawfully in existence prior to July 1, 1972, and is visible from any primary highway, including a device located beyond the adjacent area in unincorporated areas, may remain in existence without conforming to subrule 117.5(5) as long as the device otherwise conforms to all other applicable statutory and regulatory requirements. The permit provisions of rule 761—117.6(306C) apply.

b. If the advertising device is located in an adjacent area which is neither a zoned nor an unzoned commercial or industrial area, the device may remain in existence as described in paragraph "a" of this subrule only until such time as the device is acquired by the department. The permit issued for the device will be a provisional permit. See subrule 117.6(3) and rule 761—117.9(306B,306C).

**117.5(2)** *Advertising devices lawfully in existence prior to July 1, 1972, beyond 660 feet from the right-of-way.* Rescinded IAB 11/27/02, effective 1/1/03.

**117.5(3)** *Abandoned signs.* Abandoned signs which do not comply with these rules shall be removed by the department without compensation regardless of when erected.

**117.5(4)** *Advertising devices lawfully in existence prior to July 1, 1972, within adjacent areas neither zoned nor unzoned commercial or industrial.* Rescinded IAB 11/27/02, effective 1/1/03.

**117.5(5)** *Advertising devices erected after July 1, 1972.* Except as otherwise provided in this chapter, an advertising device which is visible from the main traveled way of any primary highway shall not be erected after July 1, 1972, or subsequently maintained within the adjacent area unless the advertising device complies with the following:

a. *Permit required.* A current permit from the department is required for the erection or subsequent maintenance of the advertising device.

b. *Commercial or industrial area.*

(1) An advertising device visible from the main traveled way of an interstate highway must be located within an area zoned and used for commercial or industrial purposes, as defined in rule 761—117.1(306B,306C); within 750 feet of the regularly used portion of a commercial or industrial activity visible from the main traveled way; and on the same, individual, platted parcel of land as that commercial or industrial activity. The commercial or industrial activity must be one defined under the city's or county's, as applicable, zoning ordinance.

(2) An advertising device visible from the main traveled way of a noninterstate primary highway must be located within a commercial or industrial zone or an unzoned commercial or industrial area, as defined in Iowa Code section 306C.10.

c. *Spacing within city—interstate and freeway-primary highway.* Within the corporate limits of a municipality, the following provisions apply to an advertising device which is visible from an interstate or a freeway-primary highway:

(1) The advertising device shall not be located within 250 feet of another advertising device when both are visible to traffic proceeding in any one direction.

(2) The advertising device shall not be located within the adjacent area on either side of the highway in, or within 250 feet of an interchange or rest area. The 250 feet shall be measured from the nearest point of widening for a lane constructed for the purpose of acceleration or deceleration of traffic movement to or from the main traveled way to the advertising device. The measurement shall be taken parallel to the centerline of the main traveled way and shall be taken from whichever point of widening extends the furthest from the interchange.

d. *Spacing outside city—interstate and freeway-primary highway.* Outside the corporate limits of a municipality, the following provisions apply to an advertising device which is visible from an interstate or a freeway-primary highway:

(1) The advertising device shall not be located within 500 feet of another advertising device when both are visible to traffic proceeding in any one direction.

(2) The advertising device shall not be located within the adjacent area on either side of the highway in, or within 250 feet of an interchange or rest area. The 250 feet shall be measured from the nearest point of widening for a lane constructed for the purpose of acceleration or deceleration of traffic movement to or from the main traveled way to the advertising device. The measurement shall be taken parallel to the centerline of the main traveled way and shall be taken from whichever point of widening extends the furthest from the interchange.

e. *Spacing within city—nonfreeway-primary highway.* Within the corporate limits of a municipality, the following provisions apply to an advertising device which is visible from a nonfreeway-primary highway:

(1) The advertising device shall not be located within 100 feet of another advertising device when both are visible to traffic proceeding in any one direction.

(2) The advertising device shall not be located within the daylight area. However, if a building is located within the daylight area, a wall advertising device may be attached to the building provided the device does not protrude more than 12 inches, exclusive of catwalk and lights. No part of a catwalk or lights may overhang the right-of-way. The permit for the advertising device shall be revoked if the building the device is attached to is removed.

f. *Spacing outside city—nonfreeway-primary highway.* Outside the corporate limits of a municipality, the following provisions apply to an advertising device which is visible from a nonfreeway-primary highway:

(1) The advertising device shall not be located within 300 feet of another advertising device when both are visible to traffic proceeding in any one direction.

(2) The advertising device shall not be located within the daylight area. However, if a building is located within the daylight area, a wall advertising device may be attached to the building provided the device does not protrude more than 12 inches exclusive of catwalk and lights. No part of a catwalk or lights may overhang the right-of-way. The permit for the advertising device shall be revoked if the building the device is attached to is removed.

*g. Spacing—signs separated by a building.* The distance and spacing requirements of subparagraphs “c”(1), “d”(1), “e”(1), and “f”(1), above, shall not apply to advertising devices which are separated by a building in such a manner that only one advertising device located within the minimum spacing distance is visible from a highway at any one time.

*h. Spacing—measurement of distance.* The minimum distance between two advertising devices visible to traffic proceeding in the same direction shall apply without regard to the side of the highway on which the advertising devices may be located and shall be measured along a line parallel to the centerline of the highway between points directly opposite the advertising devices. When a sign is visible and subject to control from more than one primary highway, it must meet spacing requirements along each route.

*i. Spacing—rural area next to incorporated area.*

(1) In a rural area next to an incorporated area, the first rural sign placement shall be no closer than the rural spacing requirement measured from the point where the corporation line intersects the centerline or from the point where a line normal or perpendicular to the centerline of the highway intersects the first unincorporated area within the adjacent area to a point directly opposite the first potential sign location.

(2) In those areas where the adjacent area on one side of the highway is incorporated and on the opposite side of the highway all or part of the adjacent area is not, the spacing on both sides of the highway, except for daylight spacing, shall be regulated by the rural or unincorporated area spacing requirements.

*j. Signs not considered when determining spacing.* Rescinded IAB 11/3/21, effective 12/8/21.

*k. Sizes and types.* Only the following types of advertising devices are permitted: single-face, side-by-side, double-deck, tri-vision, back-to-back, v-type, and tri-face.

(1) The multiple faces or panels of an advertising device must be contiguous or on a common structure. Side-by-side configurations are contiguous if the faces are not more than two feet apart and they are owned by the same permit holder. Side-by-side configurations must be on the same vertical and horizontal planes.

(2) A maximum of one face of an advertising device may be visible to traffic proceeding in any one direction. An advertising device other than a tri-face device may have no more than two faces.

(3) For an advertising device with one face, the maximum display area of the face is 1200 square feet. This applies to single-face, side-by-side, double-deck and tri-vision devices. For permit purposes, side-by-side and double-deck configurations are considered one face with the surface areas combined into one square footage.

(4) For an advertising device with two or more faces, the maximum display area of each face is 750 square feet. This applies to back-to-back and v-type devices (which have two faces) and tri-face devices (which have three faces).

(5) Each message on a tri-vision device must be displayed for a minimum of four seconds and the transition between messages must be completed in two seconds.

*l. Spacing—transition to freeway-primary highway.* As a segment of a noninterstate primary highway changes to a freeway-primary highway, the first freeway-primary highway sign placement shall be no closer than the freeway-primary highway spacing requirements measured along a line parallel to the centerline from a point opposite the point where the centerline of the highway and centerline of the at-grade crossing intersect to a point opposite the first potential sign location. See the appendix for an illustration of this spacing requirement.

[ARC 2645C, IAB 8/3/16, effective 9/7/16; ARC 4984C, IAB 3/11/20, effective 4/15/20; ARC 6020C, IAB 11/3/21, effective 12/8/21]

**761—117.6(306C) Outdoor advertising permits and fees required.** The owner of an advertising device must apply to the department for an outdoor advertising permit if the device is subject to subrule 117.2(1).

1. If an advertising device was in existence on July 1, 1972, application for a permit must have been made on or before July 31, 1972.

2. After July 1, 1972, the owner of an advertising device must obtain a permit from the department prior to the erection of the advertising device.

3. If an advertising device that was lawfully erected later becomes subject to these rules due to an event such as, but not limited to, a change in zoning, the establishment of a new highway or a change in the designation of a highway, the owner of the advertising device shall apply to the department for an outdoor advertising permit within 30 days after the event that made the device nonconforming. A nonconforming advertising device that complies with the

permit provisions of rule 761—117.6(306C) may remain in existence without being in compliance with subrule 117.5(5) as long as the device otherwise complies with all other applicable statutory and regulatory requirements.

**117.6(1) Application.** Application for a permit shall be made in accordance with Iowa Code section 306C.18.

a. A permit is required for each face of an advertising device; thus, a permit application must be submitted for each face. Three permits are required for a tri-face device if all three faces are visible from the main traveled way of a primary highway.

b. A copy of the current lease shall be submitted upon application for a permit.

c. Any intentional falsification or misrepresentation of information in the application or renewal process shall result in immediate denial or revocation of the permit.

**117.6(2) Fees.** Fees are applicable to all advertising devices measuring over 32 square feet in size.

a. The initial fee, payable at the time of application, is \$100 per permit. This fee is not refundable unless the application is withdrawn prior to the department’s field review of the proposed location.

b. The annual renewal fee for each permit, due on or before June 30 of each year, is as follows:

| <u>Area of Sign</u>      | <u>Annual Renewal Fee</u> |
|--------------------------|---------------------------|
| 33 to 375 square feet    | \$15                      |
| 376 to 999 square feet   | \$25                      |
| 1000 square feet or more | \$50                      |

For tri-vision signs, the area shall be calculated by multiplying the area of the face by three.

(1) The renewal fee is not refundable.

(2) Failure to timely pay the annual renewal fee when due shall result in revocation of any permit that has been issued for the advertising device and removal of the advertising device as an abandoned sign.

c. Fees shall not be prorated.

d. If an outdoor advertising permit is revoked, any permit fee paid is forfeited.

**117.6(3) Permits to be issued.**

a. The department shall issue an outdoor advertising permit in accordance with Iowa Code section 306C.18. Permits shall not be transferrable to other advertising devices or to other locations.

b. An advertising device that was lawfully in existence prior to July 1, 1972, and is located within an adjacent area which is neither a zoned nor an unzoned commercial or industrial area shall be issued a provisional permit and annual renewals thereof upon timely application and payment of the required fees, until such time as the department acquires the advertising device. See rule 761—117.9(306B,306C).

c. The department shall not prevent nor unnecessarily delay the issuance of a permit for the reason of a proposed future highway improvement project, except under any of the following conditions:

(1) The property upon which the advertising device is proposed has been appraised for the purposes of acquisition.

(2) Contact by department staff has been made with the property owner regarding compensation for the affected area.

(3) The placement of the advertising device would fail to meet the requirements of an existing corridor preservation plan in effect for the proposed location.

(4) A construction contract for the project has been initiated by the department.

**117.6(4) Permit plate.**

a. Upon approval of the application, the department shall issue a metal permit plate for the advertising face.

b. The owner of the advertising device shall securely attach the plate to the advertising face at the bottom corner nearest the main traveled way or to the support structure immediately below the bottom corner. If these locations do not permit unobscured display of the permit number, the permit plate shall be attached to another prominent area of the advertising device. The permit number shall not be obscured when viewed from the main traveled way.

c. The owner of an advertising device is responsible for replacing a permit plate that is missing or illegible. To obtain a replacement, the owner shall apply to the department and pay a \$10 fee.

d. If the department notifies the owner of the advertising device that a permit plate is not properly displayed, the owner shall within 90 days of notification either correct the situation or secure and display a replacement permit plate. Failure to properly display a permit plate after the 90-day period has expired shall result in revocation of any permit that has been issued for the advertising device and removal of the advertising device in the manner specified in subrule 117.8(1).

**117.6(5) New permit required for reconstruction or modification.** A new permit is required from the department prior to the reconstruction or modification of an advertising device subject to the permit provisions of this rule.

a. To obtain a new permit, the owner of the advertising device shall submit a new application to the department, accompanied by the initial application fee.

b. A reconstructed or modified advertising device is subject to the provisions of this chapter as if it were a new advertising device.

c. Reconstruction or modification of an advertising device prior to the issuance of the required permit shall result in revocation of any permit that has been issued for the advertising device and removal of the advertising device in the manner specified in subrule 117.8(1).

**117.6(6) *One year to erect advertising device.*** The permit for an advertising device that has not been erected within one year after the date the permit was issued shall be revoked. After revocation, a new permit is required. To obtain a new permit, the owner of the advertising device shall submit a new application to the department, accompanied by the initial application fee and a copy of the current lease.

**117.6(7) *Access.*** Access to the private property upon which an advertising device is located shall be gained from highway right-of-way only at access points designated or allowed by the department in accordance with 761—Chapter 112. An initial violation of this requirement by or on behalf of the permit holder shall result in the department sending a written warning by certified mail to the permit holder. A second violation of this requirement shall result in revocation of any permit that has been issued for the advertising device and removal of the advertising device in the manner specified in subrule 117.8(1). If a permit is revoked for an access violation, the permit holder is ineligible to apply for a permit for at least 12 months after revocation for any location within 500 feet of the revoked permit's sign location.

**117.6(8) *Destruction of vegetation.*** Without the written authorization of the department, vegetation growing on the highway right-of-way shall not be cut, trimmed, removed, or in any manner altered or damaged to improve the visibility of an advertising device. Violation of this prohibition by or on behalf of the permit holder shall result in revocation of any permit that has been issued for the advertising device and removal of the advertising device in the manner specified in subrule 117.8(1). If a permit is revoked for destruction of vegetation, the permit holder is ineligible to apply for a permit for 12 months after revocation for any location within 500 feet of the revoked permit's sign location.

**117.6(9) *Blank sign.***

a. A blank sign is:

- (1) An advertising device that has had a face physically removed.
- (2) An advertising device that does not display copy.

b. A blank sign shall not remain in blank status for a period of time exceeding six months.

c. If the department determines that an advertising device has been blank for a period of time exceeding six months, the department shall issue a notice pursuant to rule 761—117.8(306B,306C) in which the owner has 30 days to either cause it to conform or to remove it.

**117.6(10) *Destroyed sign.***

a. The permit for an advertising device which has been destroyed shall be revoked.

b. An advertising device which has been destroyed is in a condition which, if repaired, would meet the definition of reconstruction in Iowa Code section 306C.10 and is subject to subrule 117.6(5).

c. An advertising device which has been damaged, but not destroyed, may be repaired. The repair shall not be deemed an act of reconstruction.

[ARC 2645C, IAB 8/3/16, effective 9/7/16; ARC 4984C, IAB 3/11/20, effective 4/15/20; ARC 6020C, IAB 11/3/21, effective 12/8/21]

**761—117.7(306C) Official signs and notices, public utility signs, and service club and religious notices.** Rescinded ARC 6020C, IAB 11/3/21, effective 12/8/21.

**761—117.8(306B,306C) Removal procedures.** The department shall cause to be removed every advertising device illegally erected or maintained and every abandoned sign.

**117.8(1) *Removal of illegal and abandoned advertising devices.*** In accordance with Iowa Code sections 306B.5 and 306C.19, an advertising device erected or maintained in violation of Iowa Code chapter 306B or 306C or these rules is a public nuisance and may be removed by the department upon 30 days' notice, by certified mail, to the owner of the advertising device and to the owner of the land on which the advertising device is located.

a. The notice shall require the owner of the advertising device to remove the advertising device if it is prohibited, or to cause it to conform to the provisions of these rules if it is not. The department may revoke a permit issued for the advertising device as part of the same notice, in which case, the notice shall be served by restricted certified mail or by personal service.

*b.* If the advertising device has not been removed or made to conform with the provisions of these rules, the advertising device is deemed to be forfeited and the department may enter upon the land and remove the advertising device, aided by injunction to abate the nuisance and to ensure peaceful entry, if necessary.

*c.* Costs of removal, including fees and costs or expenses as may arise out of any action brought by the department to ensure peaceful entry and removal, shall be assessed against the owner of the advertising device. Should the owner of the advertising device fail to pay such fees, costs, or expenses within 30 days after assessment, the department may commence an action to collect them.

*d.* The advertising device may be used, scrapped, dismantled, or otherwise destroyed or disposed of by the department as it sees fit.

*e.* No compensation shall be paid to the owner of any advertising device which is illegally erected or maintained.

**117.8(2)** *Removal from right-of-way and other state-owned property.* The department shall remove advertising devices erected upon the right-of-way of any primary highway; see subrule 117.2(6). Unauthorized advertising devices erected upon other property owned by the state of Iowa are subject to removal by the agency, board, commission or department having control or jurisdiction of the property.

[ARC 2645C, IAB 8/3/16, effective 9/7/16; ARC 6020C, IAB 11/3/21, effective 12/8/21]

#### **761—117.9(306B,306C) Acquisition of advertising devices that have been issued provisional permits.**

**117.9(1)** The department will acquire an advertising device for which a provisional permit has been issued only if all of the following conditions are met:

- a.* Acquisition is required by federal law.
- b.* All necessary federal and state funding is available for the purpose.
- c.* The permit has not been revoked.

**117.9(2)** If the advertising device will be acquired, the department will use the following procedure:

*a.* The department shall mail or deliver to the owner of the advertising device and to the owner of the land upon which the device is located a written notice of the department's intent to revoke the provisional permit and acquire the device. The notice shall include an offer to purchase the advertising device. If good-faith negotiations with the owner of the device and the owner of the land upon which the device is located do not result in a mutually agreeable sale price, the department shall revoke the provisional permit and initiate condemnation proceedings as provided in Iowa Code chapter 6B.

*b.* In the event of condemnation, the department will take possession of the advertising device as soon as the award has been deposited with the sheriff.

#### **761—117.10(17A,306C) Contested cases.**

**117.10(1)** An applicant who has been denied an outdoor advertising permit by the department may contest the decision in accordance with 761—Chapter 13. The request for a contested case hearing shall be submitted in writing to the director of the traffic and safety bureau at the address in subrule 117.2(3). The request shall be deemed timely submitted if it is delivered or postmarked within 30 days of the department's mailing of the letter denying the application.

**117.10(2)** The owner of an outdoor advertising permit which has been revoked or canceled by the department may contest the decision in accordance with 761—Chapter 13. The request for a contested case hearing shall be submitted in writing to the director of the traffic and safety bureau at the address in subrule 117.2(3). The request shall be deemed timely submitted if it is delivered or postmarked within 30 days of the owner's receipt of the revocation notice issued by the department.

**117.10(3)** Failure to timely request a hearing on the denial, revocation, or cancellation of a permit is a waiver of the right to a hearing and a failure to exhaust administrative remedies.

[ARC 2645C, IAB 8/3/16, effective 9/7/16; ARC 4984C, IAB 3/11/20, effective 4/15/20; ARC 6020C, IAB 11/3/21, effective 12/8/21; Editorial change: IAC Supplement 4/6/22]

**761—117.11 to 117.14** Reserved.

#### **761—117.15(306C) Development directory signing.** Rescinded ARC 6020C, IAB 11/3/21, effective 12/8/21.

These rules are intended to implement Iowa Code chapters 306B and 306C as amended by 2021 Iowa Acts, Senate File 548, and section 306D.4, 23 U.S.C. 131, and 23 CFR 750.705.

[Filed 5/18/66; 761—Chapter 117 appeared as Ch 5, Highway Commission, 1973 IDR: amended January 1974 and January 1975 Supplements; amended 11/22/67, 9/27/73, 10/8/74, 12/4/74]

[Filed 5/11/87, Notice 3/11/87—published 6/3/87, effective 7/8/87]<sup>o</sup>  
[Filed emergency 5/22/96 after Notice 3/13/96—published 6/19/96, effective 5/23/96]  
[Filed 5/23/96, Notice 3/13/96—published 6/19/96, effective 7/24/96]  
[Filed 3/10/99, Notice 1/27/99—published 4/7/99, effective 5/12/99]  
[Filed 11/7/02, Notice 9/4/02—published 11/27/02, effective 1/1/03]  
[Filed 7/13/04, Notice 5/26/04—published 8/4/04, effective 9/8/04]  
[Filed 5/13/08, Notice 3/12/08—published 6/4/08, effective 7/9/08]  
[Editorial change: IAC Supplement 1/25/12]<sup>1</sup>  
[Filed ARC 2645C (Notice ARC 2543C, IAB 5/25/16), IAB 8/3/16, effective 9/7/16]  
[Filed ARC 4984C (Notice ARC 4868C, IAB 1/15/20), IAB 3/11/20, effective 4/15/20]  
[Filed ARC 6020C (Notice ARC 5859C, IAB 8/11/21), IAB 11/3/21, effective 12/8/21]  
[Editorial change: IAC Supplement 4/6/22]

# Spacing--Transition To Free

Interchange

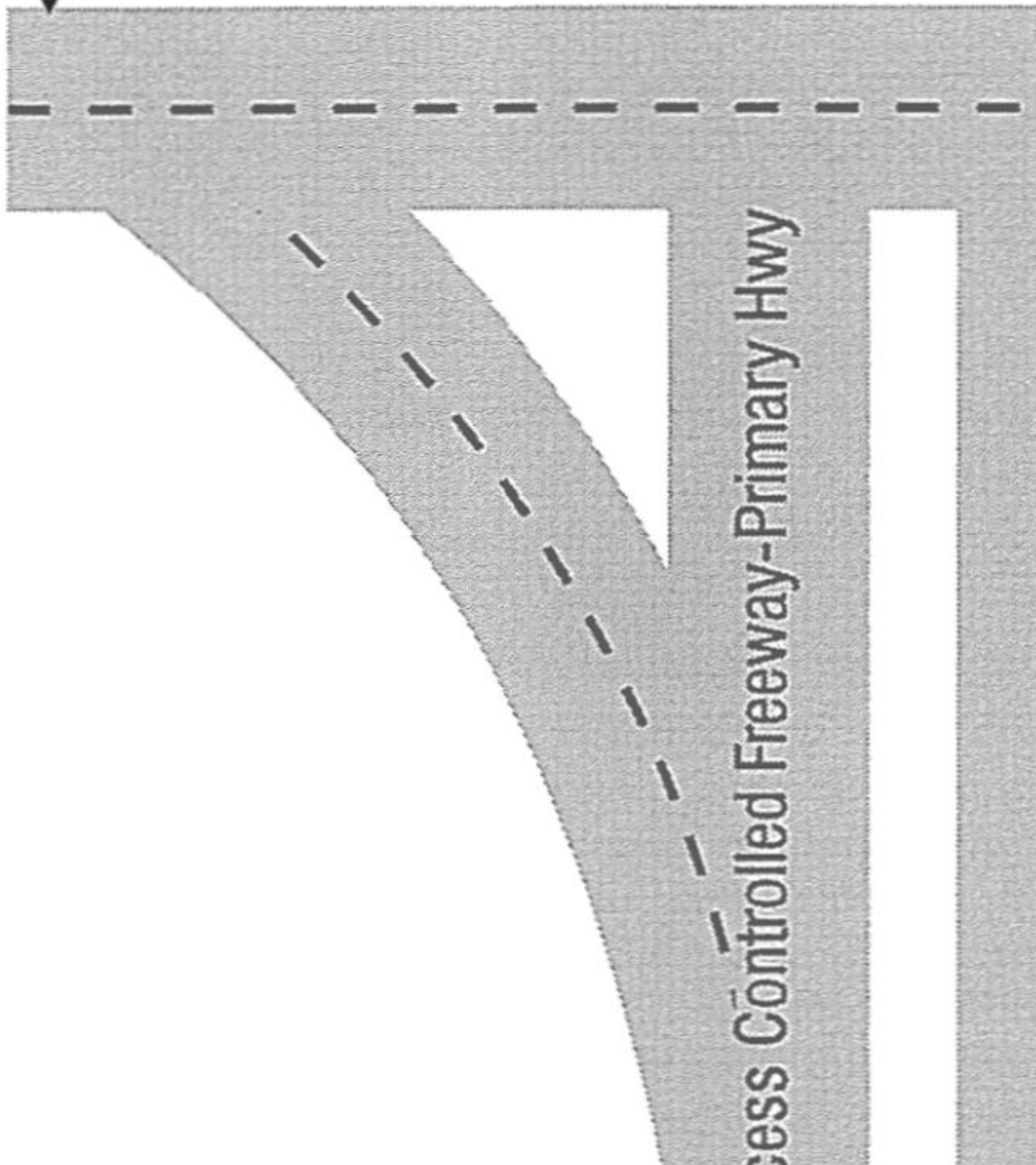

- <sup>1</sup> Spacing—Transition to Freeway-Primary Highway diagram replaced with a clearer image.



CHAPTER 118  
LOGO SIGNING

**761—118.1(306C) Introduction.** Logo signing consists of individual business signs attached to specific service signs erected by the department within the right-of-way of interstate and freeway-primary highways. The purpose of logo signing is to provide specific motorist service information of interest to the traveling public. Logo signing shall comply with this chapter and the “Manual on Uniform Traffic Control Devices,” as adopted in rule 761—130.1(321). The department shall perform all required installation, maintenance, removal and replacement of specific service signs and business signs within the right-of-way. The business signs are provided by the applicants.

[ARC 2645C, IAB 8/3/16, effective 9/7/16]

**761—118.2(306C) Definitions.**

“*Business sign*” means a separate sign attached to a specific service sign; the business sign shows the name, symbol or trademark of a business that provides the type of motorist service identified on the specific service sign.

“*General service sign*” means an official guide sign that identifies general road user services such as gas, food, lodging and camping. This sign does not provide for the placement of business signs.

“*Main line*” means the main-traveled way of an interstate or a freeway-primary highway.

“*Motorist service*” means one of the following five types of services: gas, food, lodging, camping or attraction.

“*Qualified business*” means a business that meets all requirements to participate in the logo signing program and meets all qualifications pertaining to a particular type of motorist service without the granting of an exception.

“*Ramp*” means the exit lane which carries decelerating traffic away from the main line of an interstate or a freeway-primary highway.

“*Specific service sign*” means an official guide sign that identifies one or more types of motorist services, provides directional information, and has spaces for the attachment of business signs to identify businesses providing those services.

“*Trailblazing sign*” means a specific service sign erected on the road network accessed from an interchange that has logo signing; the sign directs motorists to a particular business signed on the main line and has spaces for the attachment of business signs.

[ARC 2645C, IAB 8/3/16, effective 9/7/16; ARC 5491C, IAB 3/10/21, effective 4/14/21; Editorial change: IAC Supplement 12/15/21]

**761—118.3(306C) Erection and location of specific service signs and placement of business signs.**

**118.3(1) General.**

*a.* The department shall erect specific service signs at rural interchanges if the requirements of this chapter are met and sufficient space is available. The department may also erect specific service signs at urban, or nonrural interchanges if the requirements of this chapter are met and sufficient space is available. If sufficient space is not available for more than one specific service sign, the department may install a general service sign in lieu of a specific service sign.

*b.* Specific service signs shall be erected at an interchange only when the motorist can conveniently reenter the interstate or freeway-primary highway and continue in the same direction of travel.

**118.3(2) Main line specific service signs and placement of business signs.** Following are the requirements for main line specific service signs erected in advance of an interchange, in a single direction of travel, and limitations regarding the number and types of business signs attached to these service signs.

*a.* As spacing permits, a maximum of four main line specific service signs may be erected in advance of an interchange from which motorist services are available.

*b.* The minimum spacing required between main line specific service signs and between main line specific service signs and other official guide or destination signs on the main line is 800 feet.

*c.* If spacing limitations and the four-sign limit prohibit the erection of main line specific service signs for the types of motorist services available, preference shall be given to available gas, food, lodging, camping or attraction services, in that order.

*d.* If services are displayed, the order of display of services in the direction of travel on successive main line specific service signs is as follows: attraction, camping, lodging, food, and gas.

*e.* Each main line specific service sign is limited to six business signs. This restriction applies regardless of whether the specific service sign displays a single type of motorist service or a combination of service types.

*f.* In general, only one type of motorist service should be displayed on each main line specific service sign. However, the department may combine service types on one sign for a reason such as, but not limited to, the following:

- (1) There is limited space available on the main line for specific service signs.
  - (2) There is limited interest from qualified businesses or limited availability of motorist services at the interchange.
  - (3) There is an imbalance of qualified businesses between service types.
- g. The requirements for main line specific service signs that display a combination of motorist services are as follows:
- (1) Each combination sign is limited to six business signs.
  - (2) No more than three types of motorist services shall be represented on any combination sign.
  - (3) For a combination sign displaying three types of motorist services, the number of business signs for each service type is limited to two.
  - (4) For a combination sign that will accommodate at least four business signs, each type of motorist service displayed on the sign must have at least two positions designated for that service type.
- h. Either preference or equal representation shall be given for higher priority service types, as set out in paragraph "c" of this subrule, depending upon the motorist services available at the interchange, the interest expressed by qualified businesses in the logo signing program, and the anticipated future development of the area near the interchange.
- i. In a single direction of travel, the total number of business signs displayed for a single type of motorist service is limited to 12, and no more than two main line specific service signs shall display business signs for a single service type.
- j. The department shall designate each main line specific service sign for a particular type of motorist service, although the service sign may, in use, be displaying more than one service type, subject to paragraph "h" of this subrule. When a specific service sign designated for a particular service type exists and that sign is full, the department may grant an exception, in accordance with subrule 118.4(11), to allow the placement of a business sign for that service type on a specific service sign designated for another service type, provided that the department has displayed the legend for that service type on the service sign.

**118.3(3) Ramp specific service signs and placement of business signs.**

- a. On a single-exit interchange, the department shall erect a ramp specific service sign if businesses for that type of motorist service are signed on the corresponding main line specific service sign and one or more of these businesses or their on-premises signing is either not visible from the main line or is not visible from the ramp at or before the point where a motorist needs to make a lane decision or turning decision. However:
- (1) The department shall not erect ramp specific service signs if ramp design or spacing limitations prohibit the erection of these signs.
  - (2) The department may erect a general service sign on the ramp for the appropriate service type in lieu of a ramp specific service sign.
  - (3) If all services represented by business signs on the main line specific service signs are located the same direction from the interchange, the department may erect a general service sign on the ramp in lieu of ramp specific service signs.
- b. The number of ramp specific service signs that may be erected, the order of preference when space for ramp signs is limited, and the order in which motorist services are displayed on successive ramp signs are the same as the requirements for main line specific service signs. Also, each ramp specific service sign is limited to six business signs.
- c. Ramp specific service signs shall not be erected on double-exit interchanges.
- d. If a business sign for a motorist service is displayed on a main line specific service sign, the department has erected a ramp specific service sign for that service type, and the department has determined that the business or its on-premises signing is either not visible from the main line or is not visible from the ramp at or before the point where a motorist needs to make a lane decision or turning decision, then a ramp business sign corresponding to the main line business sign is required.
- e. A ramp business sign is allowed only if it has a corresponding business sign displayed on a main line specific service sign.

**118.3(4) Trailblazing signs and placement of business signs.**

- a. Trailblazing signs are required for a business that has a business sign displayed on a main line specific service sign when the business is neither located on nor is visible from the road that intersects the main line at the logo-signed interchange.
- b. Trailblazing signs are used only on non-fully controlled access highways and are installed only for businesses that have business signs displayed on main line specific service signs.
- c. The department shall install trailblazing signs on routes under its jurisdiction and shall make signs available for local jurisdictions to place on routes within their jurisdictions.

d. Trailblazing signs shall not display more than four business signs.

e. The department may approve the use of an official traffic control device that is placed by the department or a local jurisdiction on the public right-of-way in compliance with the “Manual on Uniform Traffic Control Devices” as a substitute for a trailblazing sign.

f. If site or other conditions do not permit the erection of a trailblazing sign, the department may approve the use of an off-premises advertising device as a substitute for a trailblazing sign if the advertising device complies, as applicable, with 761—Chapter 117 (including permit requirements) and any local regulations; the device is legible and understandable; and the device is placed along the route in advance of the intersection where the trailblazing sign would have been placed.

g. No more than two trailblazing signs, including approved substitutes, are allowed for a business. If the department determines that more than two trailblazing signs, including approved substitutes, would be needed to guide motorists to the business, the business does not qualify for logo signing at the interchange. Also, if the department determines that one or two trailblazing signs or approved substitutes are required and conditions do not permit the erection of the required trailblazing signs or approved substitutes, the business does not qualify for logo signing at the interchange.

[ARC 2645C, IAB 8/3/16, effective 9/7/16; Editorial change: IAC Supplement 12/15/21]

**761—118.4(306C) Eligibility for placement of business signs on main line specific service signs.** To qualify for placement of a business sign on a main line specific service sign, the business shall be open to the general public, shall not restrict entrance based on age, and shall meet the following requirements:

**118.4(1) Discrimination prohibited.** As a condition of approval as a participant in the logo signing program, the applicant shall give the department written assurance of the business’s conformity with all applicable laws prohibiting discrimination based on age, race, creed, color, sex, sexual orientation, gender identity, national origin, religion or disability, and a participant shall not be in breach of that assurance.

**118.4(2) Maximum distance from exit.**

a. *Three-mile limit of eligibility.* The maximum distance that a business may be located from the exit to qualify for a business sign shall not exceed three miles in either direction. The distance shall be measured from the beginning of the widening for the deceleration ramp at the exit to the entrance of the business.

b. *Limit of eligibility reduced to one mile.* In urban areas where the number of qualified businesses for a particular type of motorist service exceeds six within the three-mile limit, the department may reduce the maximum distance to one mile for that service type.

c. *Exceptions.* If there is space for additional business signs on a main line specific service sign for a particular type of motorist service and no businesses which provide that motorist service within the limit of eligibility have expressed an interest to the department in the space, the department may grant a distance exception, in accordance with subrule 118.4(11), to a business which provides that motorist service and is located within 15 miles of the exit.

**118.4(3) Gas.**

a. *Qualifications.* To qualify for placement of a business sign on a gas specific service sign, the business must:

- (1) Be appropriately licensed as required by law.
- (2) Provide vehicle services including gasoline, oil, and water.
- (3) Provide free air for tire inflation.
- (4) Provide restroom facilities and drinking water.
- (5) Operate year-round at least 12 continuous hours per day, 7 days per week.
- (6) Provide a public telephone.

b. *Exceptions.* Card-operated fueling stations may be granted an exception, in accordance with subrule 118.4(11), from the requirements to provide oil and water, restroom facilities, drinking water, and a public telephone. These fueling stations must operate 24 hours per day, 7 days per week, and must be operable by motorists without membership.

**118.4(4) Food.**

a. *Qualifications.* To qualify for placement of a business sign on a food specific service sign, the business must:

(1) Be appropriately licensed as required by law, including a state food service establishment license, except for a food service operated on Indian lands.

(2) Operate a minimum of 40 hours per week, six days per week, and serve at least two of the following meals per day: breakfast, lunch, or dinner.

1. At a minimum, breakfast shall be served from 10 a.m. to 11 a.m. and shall consist of at least two of the following items: eggs, bacon, ham, sausage, pancakes, waffles, oatmeal, cereal, fruit, muffins, toast, croissants, doughnuts or rolls and at least two of the following drinks: coffee, juice, tea or milk.

2. At a minimum, lunch shall be served from 11 a.m. to 1 p.m.
3. At a minimum, dinner shall be served from 5 p.m. to 7 p.m.
- (3) Provide a public telephone.
- (4) Have its own employees, seating, menu and cash register for the food service. The business sign must identify the entity providing the food service.
- (5) Have seating available for a minimum of ten customers.
- b. Seasonal operations.* Food service may be operated seasonally. See subrule 118.5(7) for the fee options for seasonal operations.

**118.4(5) Lodging.**

*a. Qualifications.* To qualify for placement of a business sign on a lodging specific service sign, the business must:

- (1) Be appropriately licensed as required by law.
- (2) Provide adequate sleeping accommodations consisting of a minimum of ten units each. Each unit must have a bathroom and a sleeping room. However, a bed and breakfast establishment is not required to have more than two guest rooms or provide separate bathroom facilities for each room.
- (3) Provide a public telephone.

*b. Seasonal operations.* Lodging service may be operated seasonally. See subrule 118.5(7) for the fee options for seasonal operations.

**118.4(6) Camping.**

*a. Qualifications.* To qualify for placement of a business sign on a camping specific service sign, the business must:

- (1) Meet applicable state and local standards for health and sanitation.
- (2) Have a minimum of 20 spaces for camping or parking of camping vehicles.
- (3) When in operation, be available to the public 24 hours per day.
- (4) Provide a public telephone.

*b. Seasonal operations.* Camping service may be operated seasonally. See subrule 118.5(7) for the fee options for seasonal operations.

**118.4(7) Attraction.**

*a. Qualifications.* To qualify for placement of a business sign on an attraction specific service sign, the site or attraction must:

- (1) Be appropriately licensed as required by law.
- (2) Be a site or attraction listed in paragraph "c" of this subrule.
- (3) Be of significant interest to the traveling public.
- (4) Be nationally or regionally known through a marketing or advertising plan or media articles and exposure.
- (5) Maintain normal business hours at least five days per week, totaling at least 40 hours per week. Facilities listed in subparagraph 118.4(7)"c"(12) are excepted from this requirement.
- (6) Have adequate parking accommodations, with a minimum of 30 parking spaces.
- (7) Have restroom facilities available for use by the traveling public.
- (8) Be approved by the tourist signing committee; see subrule 118.5(3).

*b. Seasonal operations.* The site or attraction may be operated seasonally. See subrule 118.5(7) for the fee options for seasonal operations.

*c. Types of qualifying sites or attractions.* The site or attraction must be one of the following:

- (1) Area of natural beauty or phenomena.
- (2) Historic site.
- (3) Cultural site or museum.
- (4) Scientific site.
- (5) Four-year accredited college or university.
- (6) Religious site.
- (7) Area of outdoor recreation.
- (8) Winery, brewery or distillery with on-site production, tours, gift shop, and tasting room.
- (9) Amusement park.
- (10) Botanical park or zoological facility.
- (11) Casino.
- (12) Stadium, coliseum, arena or racetrack with a seating capacity of at least 5,000.
- (13) Antique mall with at least 20,000 square feet devoted to retail sales.
- (14) Area containing eight or more antique shops within a three-block radius.

(15) Shopping mall or retail outlet with a minimum, active store count of 50, excluding kiosks and temporary booths within the common areas, and including only those stores that occupy owned or leased areas whose boundaries are defined by permanent walls with doors or gates.

(16) Sporting goods store or recreational retail outlet with at least 100,000 square feet devoted to retail sales.

(17) Cultural and entertainment district as officially designated by the department of cultural affairs, provided that the local jurisdiction implements a signing plan to direct motorists to the various cultural and entertainment sites within the district.

**118.4(8)** *Compliance with Iowa Code sections 306C.11 and 306C.13.* The business must be in compliance with Iowa Code sections 306C.11 and 306C.13. If an advertising device which serves the business is erected or maintained in violation of either of these sections, that business shall be disqualified from obtaining or maintaining a business sign upon any specific service sign.

**118.4(9)** *On-premises sign required.* The business must erect and maintain a legal on-premises sign at the site where the service is provided. The sign must be visible to motorists at the entrance to the business premises.

**118.4(10)** *Noncompliance.* The department shall remove and dispose of a main line business sign and the corresponding ramp and trailblazing business signs of a business that does not meet or no longer meets the requirements of this chapter. In order to have its business signs reinstalled, the business must submit a new application to the department. The new application is subject to all the requirements of this chapter, including payment of the application fee and a drawing, if needed, to select applicants.

**118.4(11)** *Granting of exceptions.*

*a.* The department may grant an exception and approve the placement of a business sign on a main line specific service sign for the following:

(1) When a specific service sign designated for a particular type of motorist service exists and that sign is full, placement of a business sign for that service type on a specific service sign designated for another service type. See paragraph 118.3(2)“j.”

(2) Maximum distance from the exit. See paragraph 118.4(2)“c.”

(3) Card-operated fueling stations. See paragraph 118.4(3)“b.”

*b.* If there is available space on a specific service sign and no application has been received by the department from a qualified business for that space, the department may allow an applicant to submit to the department for review a signed Exception Acknowledgement form along with a logo signing application.

*c.* The acknowledgement form states that if the department grants the exception and approves the application, the business is guaranteed a space on the specific service sign for at least five years if:

(1) The business pays the required fees in a timely manner;

(2) The business complies with all program requirements unrelated to the exception granted; and

(3) The department continues to maintain the specific service sign to which the business sign is attached.

*d.* After the five-year period has expired and at the end of the fiscal year, the department may remove the business sign from the specific service sign if:

(1) An exception was granted for maximum distance from the exit or a card-operated fueling station, an application has been received from a qualified business providing the same type of motorist service as the business granted the exception, and space is not available on that specific service sign.

(2) An exception was granted for the situation described in subparagraph 118.4(11)“a”(1); an application has been received from a qualified business for the service type designated for the specific service sign; and space is not available on that service sign.

[ARC 2645C, IAB 8/3/16, effective 9/7/16; ARC 5491C, IAB 3/10/21, effective 4/14/21; Editorial change: IAC Supplement 12/15/21]

## **761—118.5(306C) Application, drawing, and fees.**

**118.5(1)** *Application.*

*a.* A business requesting placement of a business sign upon a main line specific service sign shall submit a completed application form, provided by the department, along with the application fee, to the Advertising Management Section, Traffic and Safety Bureau, Iowa Department of Transportation, 800 Lincoln Way, Ames, Iowa 50010.

*b.* A separate application is not needed for the corresponding ramp business sign or trailblazing business signs. The department will advise the applicant what signs are required once the department approves the application.

*c.* Once the application is approved and the department has determined what business signs are required, the applicant shall furnish the department with business signs meeting department specifications.

d. Approved applications are valid for the fiscal year (July 1 to June 30) or portion thereof and expire on June 30. If the fees, as billed by the department, are paid by the business in accordance with subrule 118.5(5), the application is renewed on July 1.

**118.5(2) *Drawing to select applicants.*** If the number of applicants that are qualified businesses is greater than the number of vacant spaces on a main line specific service sign, the department shall hold a drawing among these applicants to select the applicants to fill the vacant spaces. If no qualified businesses have applied for the vacant spaces, the department shall consider applicants that would qualify if exceptions were granted. If the number of these applicants is greater than the number of vacant spaces, the department shall hold a drawing among these applicants to select the applicants to fill the vacant spaces.

**118.5(3) *Applications for attraction signing.*** The department shall perform an initial review of all applications for attraction signing to determine if the attraction signing meets the technical requirements, such as the maximum distance the site or attraction is allowed to be from the interchange. If the site or attraction meets the technical requirements, the department shall submit the applications to the tourist signing committee. The tourist signing committee will determine whether the applications meet the qualifications set forth in subrule 118.4(7) for an attraction under the logo signing program. The composition of the committee is set out in 761—subrule 119.5(3).

**118.5(4) *New application required for business name change.*** If a business participating in the logo signing program changes its name or franchise affiliation from that which appears on its business sign, a new application is required. If the new application is received by the department prior to the change on the business premises, the business will retain its position on the specific service sign, the department will approve the application, and no application fee is due.

**118.5(5) *Fees.*** A business is required to pay the following fees to the department for participation in the logo signing program.

a. *Application fee.* For a new application, the application fee is \$100, except that no application fee is required for an application submitted in accordance with subrule 118.5(4) (business name change). The application fee is a one-time fee and is nonrefundable once the department has performed an on-site review to verify compliance with the requirements of this chapter. The application fee shall be submitted with the application.

b. *Annual fee.* The annual fee is \$230 for each business sign posted on a main line specific service sign and \$230 for each business sign posted on a ramp specific service sign and is due on or before July 1 of each fiscal year (July 1 to June 30). However, for a new application, the department shall prorate the annual fee for the portion of the fiscal year that the business signs are installed and, following installation of the signs, shall invoice the business for the prorated annual fee; the fee is due within 30 days.

c. *Service fee.* The department may install replacement business signs at the request of the business and shall assess a \$50 service fee per business sign installed. The department shall also assess a \$50 service fee to install a renovated or new business sign that replaces a misleading, unsightly, badly faded or dilapidated sign, as specified in subrule 118.7(5). If removal of an existing business sign for the purpose of refurbishing is requested by the business, thereby requiring two service trips by the department, the service fee shall be applied per trip. The department shall invoice the business once installation is complete; the service fee is due within 30 days.

**118.5(6) *Failure to pay annual fee or service fee.*** Failure to pay the annual fee or service fee when due shall terminate the business's existing application on file with the department and shall be cause for removal and disposition of the affected business signs by the department. Termination of the application shall occur on the day of delinquency without respect to the date the department removes the business signs. In order to have its business signs reinstalled, the business must submit a new application to the department. The new application is subject to all of the requirements of this chapter, including payment of the application fee and a drawing, if needed, to select applicants.

**118.5(7) *Fee options for seasonal operations.*** Subject to subrule 118.5(5), a business that operates on a seasonal basis and is permitted to do so by this chapter has the following payment options:

a. Pay the annual fee for a full year. The department shall remove and reinstall each business sign once each year, free of additional charge, coinciding with the dates of operation, if possible.

b. Pay the annual fee for a prorated year, based on the calendar months in which the business is in operation, plus a \$50 annual service fee per business sign for removal and reinstallation services performed. The department shall remove and reinstall each business sign once each year, coinciding with the dates of operation, if possible.

c. Pay the annual fee for a prorated year, based on the calendar months in which the business is in operation, and provide main line business signs that contain a supplemental message indicating the dates of operation. Ramp business signs, if required, may contain a supplemental message indicating the dates of operation. The supplemental message must comply with subrule 118.7(4).

**118.5(8) *Fees for temporary specific service signs.*** In cases where the attachment of a business sign will require the installation of a new or larger specific service sign, an applicant that wishes to have its business sign installed

sooner than the estimated date of installation as performed by the department's contractor may request the department to erect a temporary specific service sign. The time frame for erection of a temporary specific service sign will depend on the availability of department resources, but is typically one to three months. The applicant shall be charged a fee of \$700 per main line specific service sign if none exists for that service type, \$400 per main line specific service sign if the existing specific service sign is full, and \$300 per ramp specific service sign if a ramp business sign is required but cannot be accommodated on the existing ramp specific service sign. This is in addition to the fees specified in subrule 118.5(5). The applicant shall furnish the business sign to be attached to the temporary specific service sign. When the permanent specific service sign is erected, the department shall remove the business sign from the temporary specific service sign and reinstall it on the permanent specific service sign at no additional charge.

[ARC 2645C, IAB 8/3/16, effective 9/7/16; ARC 5491C, IAB 3/10/21, effective 4/14/21; Editorial change: IAC Supplement 12/15/21]

**761—118.6(306C) Business sign blank specifications.** Business signs shall meet the following specifications for the sign blank and shall not be installed until they are inspected and approved by the department.

**118.6(1) Main line business sign blank.** Main line business signs shall be fabricated from a rectangular sheet of aluminum, between 0.074 inches and 0.125 inches thick, with 3-inch radius corners. Gas business signs shall be 48 inches wide and 36 inches high. Food, lodging, camping and attraction business signs shall be 60 inches wide and 36 inches high.

**118.6(2) Ramp business sign blank.** Ramp business signs shall be fabricated from a rectangular sheet of aluminum, between 0.074 inches and 0.125 inches thick, with 2-inch radius corners. Gas business signs shall be 24 inches wide and 16 inches high. Food, lodging, camping and attraction business signs shall be 36 inches wide and 16 inches high.

**118.6(3) Trailblazing business sign blank.** Trailblazing business signs shall be fabricated from a rectangular sheet of aluminum, between 0.074 inches and 0.125 inches thick, with 2-inch radius corners. All trailblazing signs shall be 20 inches wide and 12 inches high.

[Editorial change: IAC Supplement 12/15/21]

**761—118.7(306C) Business sign face specifications.** Business signs shall meet the following specifications for the sign face and shall not be installed until they are inspected and approved by the department. Businesses shall submit a proposed sign design to the department for approval before proceeding with fabrication.

**118.7(1) Design layout.** A legend layout or a logo layout, but not both, shall be used for the design of the sign's message.

*a. Legend layout.* A legend layout shall reflect the name of the business in white letters on a blue background. Recommended letter height is 10 inches on a main line business sign, 4 inches on a ramp business sign, and 3 inches on a trailblazing business sign. The recommended number of text lines is one or two. Reducing the letter height or adding a third text line will reduce the legibility of the message.

*b. Logo layout.* A logo layout shall reflect the nationally, regionally, or locally known symbol or trademark of the business, using colors consistent with customary use of the symbol or trademark and resembling the business's on-premises sign. The symbol or trademark may be modified to improve legibility.

**118.7(2) Borders.** Main line business signs shall have a white  $\frac{3}{4}$ -inch border on the outside edge of the sign. Ramp business signs shall have a white  $\frac{1}{2}$ -inch border on the outside edge of the sign. Trailblazing business signs shall have a white  $\frac{1}{2}$ -inch border on the outside edge of the sign. If a logo layout has a white background, no border is required. No inset border is allowed on legend layouts, and no inset border is allowed on logo layouts unless it is customary usage for the symbol or trademark.

**118.7(3) ReflectORIZATION.** All business signs must be retroreflective.

**118.7(4) Supplemental messages.**

*a.* With department approval, a supplemental message such as "OPEN 24 HRS," "DIESEL," "E-85," "MECHANIC ON DUTY," "24 HR TOWING," "RV ACCESS," or the dates of operation for seasonal operations may be displayed on a main line business sign provided the letter height is at least 5 inches. Approval shall be limited to essential motorist information and does not extend to messages such as, but not limited to, "INDOOR POOL," "CAR WASH" or "PLAY AREA."

*b.* With departmental approval, a scaled-down version of the supplemental message used on the main line business sign may be displayed on ramp business signs provided the letter height is at least 2 inches.

*c.* Business signs are limited to one supplemental message per business sign.

**118.7(5) Misleading or dilapidated signs.** No business sign shall be displayed if it would mislead or misinform the traveling public, or if it is unsightly, badly faded, or dilapidated. The department may remove or mask business signs that violate these provisions. The department shall require a business to provide a renovated or new business

sign to replace a misleading, unsightly, badly faded or dilapidated sign and shall assess a \$50 service fee to install the renovated or new sign.

**118.7(6)** *Signs that interfere with or imitate official signs.* Messages, trademarks, or brand symbols that interfere with, imitate, or resemble any official warning or regulatory traffic sign, signal or device are prohibited.

**118.7(7)** *Damaged signs.* The department is not responsible for damages to business signs caused by vandalism, vehicle accidents or acts of God. If a business sign is so damaged and it requires repair or replacement, the business shall provide a renovated or new business sign to the department for replacement of the damaged business sign. If a specific service sign is damaged beyond repair, the department shall erect a temporary specific service sign to accommodate the reattachment of the affected business signs.

[ARC 2645C, IAB 8/3/16, effective 9/7/16; Editorial change: IAC Supplement 12/15/21]

**761—118.8(306C) RV symbol.** Rescinded ARC 2645C, IAB 8/3/16, effective 9/7/16.

These rules are intended to implement Iowa Code section 306C.11.

[Filed 5/11/87, Notice 3/11/87—published 6/3/87, effective 7/8/87]

[Filed 8/7/96, Notice 7/3/96—published 8/28/96, effective 10/2/96]

[Filed 5/12/99, Notice 3/24/99—published 6/2/99, effective 7/7/99]

[Filed 11/7/02, Notice 9/4/02—published 11/27/02, effective 1/1/03]

[Filed 10/11/07, Notice 8/15/07—published 11/7/07, effective 12/12/07]

[Filed ARC 2645C (Notice ARC 2543C, IAB 5/25/16), IAB 8/3/16, effective 9/7/16]

[Filed ARC 5491C (Notice ARC 5314C, IAB 12/16/20), IAB 3/10/21, effective 4/14/21]

[Editorial change: IAC Supplement 12/15/21]

CHAPTER 119  
TOURIST-ORIENTED DIRECTIONAL SIGNING

**761—119.1(321) Definitions.**

“*Destination*,” for the purpose of this chapter, means a business, service, activity, or site that meets the program requirements established in rule 761—119.3(321).

“*Primary highway*,” for the purpose of this chapter, means those roads and streets both inside and outside the boundaries of municipalities which are under department jurisdiction but does not include an interstate highway or a freeway primary highway as defined in Iowa Code section 306C.10.

“*Tourist-oriented directional signing*” means a system of guide signs with one or more sign panels that display the identification of and directional information for an eligible destination.

[ARC 4436C, IAB 5/8/19, effective 6/12/19; ARC 6971C, IAB 4/5/23, effective 5/10/23]

**761—119.2(321) General.**

**119.2(1) Conformance to MUTCD.** Tourist-oriented directional signing shall conform to the “Manual on Uniform Traffic Control Devices” (MUTCD), as adopted in rule 761—130.1(321).

**119.2(2) Spacing and location.**

a. Tourist-oriented directional signing shall be installed only when sufficient space is available. The determination of whether sufficient space is available is the responsibility of the department in accordance with the MUTCD and department policies. If the number of applications exceeds the capacity to accommodate all of the requests, a lottery drawing shall be held to determine which applications will be accepted. However, destinations that are already participating in the tourist-oriented directional signing program shall not be subject to the lottery drawing, provided that each applicant’s participation remains in compliance with this chapter, including the timely payment of fees.

b. Tourist-oriented directional signing shall be installed in advance of the intersection where the motorist leaves the primary highway system to travel to the destination. However, tourist-oriented directional signs may be placed on a higher-classified highway to direct motorists onto a lower-classified highway, or on a greater-traveled highway to direct motorists onto a lesser-traveled highway.

c. Tourist-oriented directional signing shall not be placed at interchanges. If an at-grade intersection on a primary highway is replaced with an interchange, the intersection will no longer qualify for tourist-oriented directional signing. Any tourist-oriented directional signing previously erected shall be removed by the department.

d. If an adjacent landowner complains to the department about the placement of a tourist-oriented directional sign, the department shall attempt to reach an agreement with the landowner for relocating the sign. If possible, the sign shall be relocated to the least objectionable place.

e. Tourist-oriented directional signing shall not be placed within the urban area as established by the U.S. Census Bureau of an incorporated municipality with a population of 5000 or more.

**119.2(3) Message.** The message on a tourist-oriented directional sign is limited to a descriptive name, a directional arrow, the travel distance to the destination, and in some cases for motorist services, an additional short word or acronym indicating an essential fuel type such as diesel, E-85, or EV (electric vehicle charging station).

[ARC 1202C, IAB 12/11/13, effective 1/15/14; ARC 4436C, IAB 5/8/19, effective 6/12/19; ARC 6971C, IAB 4/5/23, effective 5/10/23]

**761—119.3(321) Eligibility requirements for a destination.** This rule describes the general requirements which a destination must meet to qualify for tourist-oriented directional signing.

**119.3(1) Operational requirements.**

a. The destination shall be open to the general public for a minimum of 20 hours per week.

b. The destination shall be open to the general public at least four days per week.

c. Hours of operation that are available to the public only by appointment, reservation, or membership shall not count toward meeting the minimum requirements set forth in this subrule.

d. Manufacturing plants, trucking terminals, distribution centers, warehouses, production facilities, and other industrial activities for which the general public has access but for which employees and contractors are the primary users shall not qualify as destinations. However, if the facility has developed public tours and is prepared to receive unscheduled visitors, the tourist signing committee may consider this information during the application review and make an exception to the general rule as set forth above.

e. Unless the destination is open 24 hours per day, the hours of operation shall be conspicuously posted on the destination premises.

f. Entrance to the destination shall not be restricted based on age.

g. The destination shall be properly licensed by all governing authorities relative to the nature of the activity engaged in by the destination.

h. Seasonal destinations shall be in operation for a minimum of four consecutive weeks.

**119.3(2) Location requirements.**

a. The destination shall be located within ten miles of the intersection on the primary highway where the tourist-oriented directional signs will be placed.

b. The destination shall be located outside the city limits of any incorporated municipality with a population of 5,000 or more (population as established by the U.S. Census Bureau).

c. The destination shall not be visible from the highway in a way that allows for motorists to react safely by slowing and making a turn.

d. The building and site for the destination shall be appropriately designed and suited for the purpose. Buildings used principally as a residence shall not be used, unless there is a convenient, separate, and well-marked entrance to access the activity identified on the sign.

e. Buildings and grounds must be maintained in a manner consistent with standards generally accepted for that type of business or activity.

**119.3(3) Customer base.** A destination shall derive a major portion of income or visitors from road users not residing in the area of the destination.

**119.3(4) Compliance with other laws and regulations.**

a. The destination shall comply with all applicable laws concerning public accommodations without regard to age, race, creed, color, sex, sexual orientation, gender identity, national origin, religion or disability.

b. The destination shall comply with Iowa Code chapter 306B; Iowa Code chapter 306C, division II; Iowa Code chapter 318; and all other statutes or administrative rules regulating outdoor advertising.

[ARC 1202C, IAB 12/11/13, effective 1/15/14; ARC 6971C, IAB 4/5/23, effective 5/10/23]

**761—119.4(321) Specific eligibility requirements for the type of activity or site.** Rescinded ARC 6971C, IAB 4/5/23, effective 5/10/23.

**761—119.5(321) Application and approval procedure.**

**119.5(1)** Applications for tourist-oriented directional signing shall be submitted to: Advertising Management Section, Traffic and Safety Bureau, Iowa Department of Transportation, 800 Lincoln Way, Ames, Iowa 50010.

**119.5(2)** The department of transportation shall verify compliance with the minimum requirements and develop an agenda for the tourist signing committee's review of applications that meet the minimum requirements. The department shall return to the applicant an application that does not meet the minimum requirements.

**119.5(3)** The tourist signing committee consists of representatives from the economic development authority, the department of transportation, the department of agriculture and land stewardship, the department of natural resources, the department of cultural affairs, Iowa's tourism industry, and the outdoor advertising association for Iowa. The committee's responsibility is to approve or deny applications.

[ARC 1202C, IAB 12/11/13, effective 1/15/14; ARC 4436C, IAB 5/8/19, effective 6/12/19; ARC 6971C, IAB 4/5/23, effective 5/10/23]

**761—119.6(321) Installation, maintenance, replacement and removal.**

**119.6(1) Installation and maintenance of tourist-oriented directional signs.** Except as provided in subrule 119.6(4), the department shall fabricate and perform all required installation, maintenance, removal and replacement of tourist-oriented directional signs that are located within the right-of-way.

a. The department shall design the tourist-oriented directional sign and provide a scaled drawing of it to the applicant prior to sign fabrication.

b. A tourist-oriented directional sign shall not be installed until the applicant has paid the department the initial fee specified in subrule 119.6(3).

**119.6(2) Installation and maintenance of trailblazing signs.** If the destination is not located adjacent to the secondary road or city street intersecting the primary route, trailblazing signs are required. Trailblazing signs shall conform to requirements in the MUTCD.

a. The department shall fabricate trailblazing signs and provide them to cities and counties for installation on secondary roads and city streets. Cities and counties are responsible for the installation and maintenance of trailblazing signs on routes under their jurisdiction.

b. Trailblazing signs shall not be installed until the applicant has paid the department a fee for the cost of sign fabrication.

c. Tourist-oriented directional signs shall not be installed until necessary trailblazing signs are in place.

**119.6(3) *Initial and renewal fees.*** The initial fee, payable once an application is approved, is \$350 for each 72" × 18" sign placed along the primary highway and \$26 for each trailblazing sign placed along a nonprimary highway. These fees include the cost of sign fabrication and installation but do not include any additional fees which may be required by local jurisdictions for the placement of trailblazing signs along local road systems. The annual renewal fee, payable on or before June 30 of each year, is \$50 per sign, excluding trailblazing signs. This fee covers the administrative costs and normal maintenance.

**119.6(4) *Seasonal destination.*** A tourist-oriented directional sign for a seasonal destination must either be masked or have a "closed" panel installed over the sign's directional information when the destination is closed or when the hours of operation decrease below the minimum requirements during the off-season period. Either the department or the destination with the department's permission shall perform the work. If the department performs the work, the approved applicant must pay the actual cost to install and remove the "closed" panel or to mask the sign.

**119.6(5) *Required replacement.***

*a.* The department shall determine when a tourist-oriented directional sign is no longer serviceable and needs to be replaced. If such a determination is made, the destination must pay for the cost of a new sign and its installation prior to installation.

*b.* The department is not responsible for theft of or damage to any tourist-oriented directional sign. If a sign requires repair or replacement due to theft or damage, the destination must pay the cost of the repair or replacement and installation. At the destination's request, this cost may be spread over a 12-month period.

**119.6(6) *Not-for-profit organizations.*** A not-for-profit destination is exempted from all fees and costs associated with the installation and maintenance of a single set of signs at a location determined by the department to be the most reasonable approach to the destination. If additional locations are requested by the not-for-profit organization, all fees and costs described in this chapter shall apply to the additional locations.

**119.6(7) *Removal.*** The department shall remove a tourist-oriented directional sign if the destination no longer qualifies for tourist-oriented directional signing. As official signs, all tourist-oriented directional signs are the property of the department and shall not be given to applicants upon the signs' removal.

[ARC 4436C, IAB 5/8/19, effective 6/12/19; ARC 6971C, IAB 4/5/23, effective 5/10/23]

These rules are intended to implement Iowa Code section 321.252.

[Filed 5/11/87, Notice 3/11/87—published 6/3/87, effective 7/8/87]

[Filed 5/3/89, Notice 3/22/89—published 5/31/89, effective 7/5/89]

[Filed 8/7/96, Notice 7/3/96—published 8/28/96, effective 10/2/96]

[Filed 11/7/02, Notice 9/4/02—published 11/27/02, effective 1/1/03]

[Filed ARC 1202C (Notice ARC 1018C, IAB 9/18/13), IAB 12/11/13, effective 1/15/14]

[Filed ARC 4436C (Notice ARC 4317C, IAB 2/27/19), IAB 5/8/19, effective 6/12/19]

[Filed ARC 6971C (Notice ARC 6885C, IAB 2/8/23), IAB 4/5/23, effective 5/10/23]



CHAPTER 120  
PRIVATE DIRECTIONAL SIGNING  
Rescinded **ARC 6020C**, IAB 11/3/21, effective 12/8/21

CHAPTER 121  
ADOPT-A-HIGHWAY PROGRAM  
Rescinded **ARC 8244C**, IAB 10/2/24, effective 11/6/24

CHAPTER 122  
KEEP IOWA BEAUTIFUL PROGRAM  
Rescinded **ARC 1516C**, IAB 7/9/14, effective 8/13/14

CHAPTER 123  
REST AREA SPONSORSHIP PROGRAM  
Rescinded **ARC 3561C**, IAB 1/3/18, effective 2/7/18

CHAPTER 124  
HIGHWAY HELPER SPONSORSHIP PROGRAM  
Rescinded **ARC 8244C**, IAB 10/2/24, effective 11/6/24  
*CONSTRUCTION*

CHAPTER 125  
GENERAL REQUIREMENTS AND COVENANTS FOR HIGHWAY  
AND BRIDGE CONSTRUCTION  
Rescinded **ARC 3400C**, IAB 10/11/17, effective 11/15/17

CHAPTER 126  
CONTRACTS SET ASIDE FOR  
DISADVANTAGED BUSINESS ENTERPRISES  
[Prior to 6/3/87, Transportation Department[820]—(06,G) Ch 2]  
Rescinded IAB 9/5/01, effective 10/10/01

CHAPTER 127  
BIKEWAYS AND WALKWAYS  
[Prior to 6/3/87, Transportation Department[820]—(06,A) Ch 2]  
Rescinded IAB 3/29/95, effective 5/3/95

CHAPTER 128  
CONSTRUCTION PROJECTS  
Rescinded IAB 9/4/02, effective 10/9/02

CHAPTER 129  
Reserved



## TRAFFIC OPERATIONS

CHAPTER 130  
SIGNING MANUAL

[Prior to 6/3/87, Transportation Department[820]—(06,K) Ch 2]

**761—130.1(321) Manual.** The “Manual on Uniform Traffic Control Devices” (MUTCD), 2009 Edition with Revision Numbers 1 and 2, dated May 2012, published by the U.S. Department of Transportation, Federal Highway Administration, shall constitute the manual and specifications for a uniform system of traffic control devices for use upon the highways of this state.

**130.1(1)** The department makes the following exception to the MUTCD for school zones: In Part 2, Section 2B.04, paragraph 12, of the MUTCD, Right-of-Way at Intersections, Standard, in lieu of the sentence “Portable or part-time STOP or YIELD signs shall not be used except for emergency and temporary traffic control zone purposes,” the department adopts the following: “Portable or part-time STOP signs may be used only in the following situations:

- “1. When necessary for emergency and temporary traffic control zone purposes, or
- “2. In school zones at appropriate school crosswalks.”

**130.1(2)** Copies of the MUTCD are available for examination at the Office of Traffic and Safety, Iowa Department of Transportation, 800 Lincoln Way, Ames, Iowa 50010. The MUTCD is also available on the Internet at <http://mutcd.fhwa.dot.gov>.

This rule is intended to implement Iowa Code sections 321.249 and 321.252.

[ARC 9362B, IAB 2/9/11, effective 3/16/11; ARC 1986C, IAB 5/13/15, effective 6/17/15]

[761—Chapter 130 appeared as Highway Commission rule, 1973 IDR, p. 517; amended January 1975

Supplement, p. 89. (Note: No chapter number was given.)]

[Filed 3/11/65; amended 5/16/72, 9/24/74]

[Filed 8/13/79, Notice 5/30/79—published 9/5/79, effective 10/10/79]

[Filed 11/16/84, Notice 8/15/84—published 12/5/84, effective 1/9/85]

[Filed 10/2/85, Notice 8/14/85—published 10/23/85, effective 11/27/85]<sup>1</sup>

[Filed 2/6/87, Notice 12/17/86—published 2/25/87, effective 4/1/87]

[Filed 5/11/87, Notice 3/11/87—published 6/3/87, effective 7/8/87]

[Filed 11/1/89, Notice 9/20/89—published 11/29/89, effective 1/3/90]

[Filed 11/2/94, Notice 9/28/94—published 11/23/94, effective 12/28/94]

[Filed 4/17/96, Notice 3/13/96—published 5/8/96, effective 6/12/96]

[Filed 10/10/02, Notice 8/7/02—published 10/30/02, effective 12/4/02]

[Filed 9/14/05, Notice 8/3/05—published 10/12/05, effective 11/16/05]

[Filed ARC 9362B (Notice ARC 9290B, IAB 12/15/10), IAB 2/9/11, effective 3/16/11]

[Filed ARC 1986C (Notice ARC 1885C, IAB 2/18/15), IAB 5/13/15, effective 6/17/15]

<sup>1</sup> Effective date of subrule 2.1(2) delayed until the expiration of 45 calendar days into the 1986 Session of the General Assembly pursuant to Iowa Code section 17A.8(9). The 1986 General Assembly took no formal action; therefore, subrule 2.1(2) is effective 2/28/86.



CHAPTER 131  
SIGNING ON PRIMARY HIGHWAYS  
[Prior to 6/3/87, Transportation Department[820]—(06,K) Ch 3]

**761—131.1(321) Destination signs at an intersection.** This rule establishes the requirements and procedure for placing destination signs on a primary highway at the intersection of a secondary road.

**131.1(1) Requirements.**

*a.* A destination shown on a primary highway destination sign shall be one reached by following either the secondary road or the primary highway.

*b.* A secondary road destination shall not be located beyond the next primary highway.

*c.* The secondary road must be marked with sufficient route markers, arrows, and destination signs to guide a motorist through intersecting roads, winding roads and built-up areas.

*d.* To qualify for signing, a secondary road destination must be one of the following:

(1) Another primary highway.

(2) An incorporated community.

(3) An unincorporated village shown on the state transportation map.

(4) A publicly maintained park.

(5) A public-use or publicly owned airport.

(6) A historical site recognized and approved by the department of cultural affairs.

*e.* The department shall determine which primary highway destinations qualify for signing.

**131.1(2) Procedure.**

*a.* To request placement of destination signs at the intersection of a primary highway and a secondary road, the county engineer shall obtain Form 740023, "Proposed Directional Signing," from the appropriate district office, complete it and submit it to the appropriate district office. The county engineer may request signs for destinations on the secondary road that meet the criteria in paragraph 131.1(1) "d" and destinations on the primary highway.

*b.* If destination signs are already in place at the intersection, any person may request listing additional destinations by submitting a written request to the traffic and safety bureau.

*c.* The traffic and safety bureau shall determine if a request is to be approved or denied and notify the requester of its action on the request.

*d.* The department shall install and maintain the primary highway destination signs. The department shall also furnish primary route markers and auxiliary signs for installation on the secondary road and install secondary road route markers and auxiliary signs furnished by the county on the primary highway.

[ARC 1986C, IAB 5/13/15, effective 6/17/15; ARC 5426C, IAB 2/10/21, effective 3/17/21]

**761—131.2(321) Erection of signs for numbered business routes.** This rule establishes signing requirements, responsibilities and procedures for the erection of signs for numbered business routes.

**131.2(1) Definition.** A business route is a route principally within the corporate city limits which provides the public a marked route through the business area of the city as an alternate to the regular route which bypasses the city or its congested area.

**131.2(2) Requirements.**

*a.* The business route must connect with the regular route outside the congested area or the corporate limits, but within a reasonable distance of those limits.

*b.* The route must be designated over paved streets and highways which are available to all types of vehicles.

**131.2(3) Responsibilities.**

*a.* All business route identification signs, including the "Business" route sign, U.S. or state numbered route marker and directional arrow, will be furnished by the city.

*b.* The city and county shall erect all signs required on streets and highways within their respective jurisdictions.

*c.* The department of transportation shall erect all signs required within the right-of-way of primary highways and primary highway extensions.

*d.* The municipality shall maintain all signs at proper position and elevation, and in a clean and legible state.

**131.2(4) Procedures.**

*a.* A request for the designation of a business route shall be submitted by a city to the appropriate district office.

*b.* The traffic and safety bureau shall determine if the request is to be approved or denied.

*c.* The traffic and safety bureau shall designate the signing requirements for establishment of the business route.

**131.2(5)** *Service level to be maintained.* If either the signs or the streets and highways are not maintained at acceptable levels for traffic service, the department of transportation may require removal of the signs designating a business route.

[ARC 5426C, IAB 2/10/21, effective 3/17/21]

**761—131.3(321) Erection of signs for schools.** This rule establishes requirements and procedures for the erection of signs for schools.

**131.3(1) Requirements.**

a. Signs may be erected for a junior college, college, university or an area community college.

(1) The school shall provide an accredited program of academic study or an approved program of technical or vocational training under the supervision of the state department of education or the state board of regents.

(2) The school shall have a minimum enrollment of 500 full-time students at that school site.

b. Signs may be erected for a public or private elementary, middle, junior high or senior high school.

(1) The school shall provide an accredited program of academic study under the supervision of the state board of education.

(2) Signs shall not be installed on the federal system of interstate highways or at freeway interchanges.

c. The school is not immediately adjacent to a primary highway or a primary highway extension.

d. The school is located on and directly served by the street or highway considered for signing.

**131.3(2) Procedures.**

a. A request for school signing shall be submitted to the appropriate district office.

b. The traffic and safety bureau shall determine if the request is to be approved or denied.

c. Signs shall be furnished, erected and maintained by the department of transportation upon determination that the requirements of subrule 131.3(1) have been satisfied.

[ARC 5426C, IAB 2/10/21, effective 3/17/21]

**761—131.4(321) Erection of camping service signs on interstate highways.** This rule establishes requirements and procedures for the erection of camping service signs.

**131.4(1) Definition.** “All-weather roads” are roads with sufficient surfacing so as to be passable regardless of weather conditions.

**131.4(2) Requirements.**

a. The distance of the camp facility from the nearest off-ramp intersection with the intersected highway or street should not exceed five miles via an all-weather road or street.

b. Campsites should have a minimum of 20 spaces available for camping and parking.

c. The camping area and all facilities shall be available to the public 24 hours a day on a year-round basis. If a camping facility meets the “24 hours a day” condition but is operated on a seasonal basis, camping service signs shall be provided with the condition that the sign be masked (at no cost to the owner) during that part of the year when the facility is not open to the public.

**131.4(3) Procedures.**

a. A request for camping service signs should be made to the appropriate district office.

b. The appropriate district office shall forward Form 810013, “Application for Camping Service Sign, Interstate,” to the requesting camp owner.

c. The camp owner shall complete Form 810013, sign it, and return it to the appropriate district office.

d. The appropriate district office shall review Form 810013 and verify by inspection that the requirements established in subrule 131.4(2) have been met.

e. When the appropriate district office has verified through inspection that the requirements are satisfied, the district traffic technician shall complete and sign Form 810013, signifying approval of the application. A copy of the approved application shall be promptly forwarded to the applicant.

f. Upon approval of Form 810013, the department of transportation shall erect and maintain, at no cost to the camp owner, camping service signs on the interstate highway. (The department of transportation shall also bear the cost of masking camping service signs during the periods that seasonal campsites are closed to the public.)

**131.4(4) Conditions.**

a. The campground must meet applicable state and local standards for health and sanitation. Camping service signs may be removed if the department is notified by the responsible state or local agency that the campground is in violation of these standards.

b. Camping service signs may be removed if the campground is found to be in violation of any other requirement of this rule.

- c. Signing shall not be reinstated without proper notification that the violation has been corrected.

[ARC 1986C, IAB 5/13/15, effective 6/17/15; ARC 5426C, IAB 2/10/21, effective 3/17/21]

**761—131.5(321) Erection of signs for sanitary landfills.** This rule establishes requirements and procedures for the erection of signs for sanitary landfills.

**131.5(1) Requirements.**

- a. The access from the primary highway must be a direct connection to the sanitary landfill;  
b. If the access to the sanitary landfill is connected to a secondary road, the county must make a request on Form 740023, "Proposed Directional Signing," to the appropriate district office; and  
c. The sanitary landfill site must be operated under a permit issued by the Iowa department of natural resources.

**131.5(2) Procedure.**

- a. A request for sanitary landfill signing shall be submitted to the appropriate district office.  
b. The county shall be promptly informed of the final disposition of the request.  
c. If the request is approved, the department of transportation shall secure, erect and maintain the sanitary landfill sign on the primary highway.

[ARC 5426C, IAB 2/10/21, effective 3/17/21]

**761—131.6(321) Erection of signs for special events.** This rule establishes requirements, procedures and responsibilities for the erection of signs for special events.

**131.6(1) Requirements.**

- a. Expected attendance of over 10,000 people per day.  
b. Gathering to involve attendance of people on a statewide basis or nationwide basis.

**131.6(2) Procedures.**

- a. A request for special event signing shall be submitted to the appropriate district office.  
b. The traffic and safety bureau shall determine if the request is to be approved or denied.  
c. The traffic and safety bureau shall designate the signing requirements and locations for the signs.

**131.6(3) Responsibilities.**

- a. The required signs shall be furnished by the sponsoring organization.  
b. The signs shall be placed and removed by the sponsoring organization.  
c. The sponsoring organization shall provide for personnel to direct traffic during the duration of the event.

**131.6(4) Duration of placement.** The signs are to be in place only on the day or days of the special event.

[ARC 1986C, IAB 5/13/15, effective 6/17/15; ARC 5426C, IAB 2/10/21, effective 3/17/21]

**761—131.7(321) Erection of signs for organized off-highway camps.** This rule establishes requirements, procedures and responsibilities for the erection of signs for organized off-highway camps.

**131.7(1) Requirements.** The camps shall be permanent and operated by recognized and established civic, religious, and nonprofit charitable organizations.

**131.7(2) Procedures.**

- a. A request for signing shall be submitted to the appropriate district office.  
b. The traffic and safety bureau shall determine if the request is to be approved or denied.

**131.7(3) Financial responsibility.** The department of transportation shall purchase, install and maintain the signs upon the prepayment by the organization of the cost of purchase, installation and maintenance.

[ARC 5426C, IAB 2/10/21, effective 3/17/21]

**761—131.8(321) Erection of signs for county conservation parks.** This rule establishes requirements, procedures and responsibilities for the erection of signs for county conservation parks.

**131.8(1) Requirements.** The park shall have as its primary purposes outdoor recreation and nature appreciation.

**131.8(2) Procedures.**

- a. A request for county conservation park signing shall be submitted on Form 740023, "Proposed Directional Signing," to the appropriate district office.  
b. The traffic and safety bureau shall review and make the final determination on the request and promptly inform the county of the determination.

**131.8(3) Responsibilities.**

- a. If the request is approved, the traffic and safety bureau shall design the signs and furnish the applicant a scaled drawing of the required signs.  
b. The applicant shall furnish to the department of transportation the required signs at a location specified by the department.

c. The department of transportation will erect the signs and provide normal maintenance.

d. If the sign(s) must be replaced for any reason, the applicant shall furnish new sign(s) to the department of transportation.

[ARC 5426C, IAB 2/10/21, effective 3/17/21]

**761—131.9(321) Erection of no parking signs.** This rule establishes procedures and conditions for the erection of no parking signs on rural primary highways.

**131.9(1) Procedures.** Requests for the erection of no parking signs on rural primary highways shall be made by the Iowa state patrol or sheriff to the appropriate district office.

**131.9(2) Conditions.** The signs will be furnished, erected and maintained by the department of transportation; however, they shall be removed if the department determines the parking prohibition is not enforced.

[ARC 5426C, IAB 2/10/21, effective 3/17/21]

**761—131.10(321) Signing for named routes and memorial bridges.** This rule establishes the requirements and procedures for placing special signs along the primary highway for the purpose of designating a primary highway as a memorial highway, a historic trail, or a scenic trail or a bridge on the primary highway as a memorial bridge.

**131.10(1) Definitions.**

“*Historic trail*” means a route located on or near the approximate alignment of a trail on which a person or group traveled while making a journey of regional or national historic significance.

“*Manual on Uniform Traffic Control Devices (MUTCD)*” means the Federal Highway Administration standards on traffic control devices, as adopted in rule 761—130.1(321).

“*Memorial bridge*” means a bridge on the primary highway that has been given a name to commemorate a person, group, place or event of regional or national significance.

“*Memorial highway*” means a primary highway that has been given a name to commemorate a person, group, place or event of regional or national significance.

“*Named route*” means a memorial highway, a historic trail or a scenic trail.

“*Primary highway,*” for the purpose of this rule, does not include an interstate highway.

“*Scenic trail*” means a route, loop or circuit with special scenic or recreational appeal.

**131.10(2) General requirements.**

a. Interstate highways have been designated as the “Dwight D. Eisenhower National System of Interstate and Defense Highways” and are not eligible for naming under these rules. However, bridges on interstate highways may be named.

b. The named route shall be continuous with no breaks at the boundaries of political subdivisions. Each city and county through which a named route passes must provide the department a resolution in support of the route designation. This includes portions of the route off the primary highway system. The memorial bridge shall be located on the primary highway, and the city and county in which the bridge is located must provide a resolution to the department in support of the bridge designation.

c. A memorial highway should normally encompass the entire length of a primary highway within the state. However, it is permissible to name a section of a primary highway if the section is unique or independent by virtue of its design characteristics, such as a freeway, or its geographic location, such as a segment between two junctions. No more than one name shall be used for a bridge or for the same section of a route.

d. Signs designating a named route or memorial bridge shall be furnished and paid for by the applicant including any replacements needed due to sign deterioration or damage. Failure to comply with this requirement may result in removal of all signs for the named route or memorial bridge along the primary highway. The applicant is responsible for providing the department with the applicant’s current contact information. If the department is unable to make contact with the applicant when replacement signs are needed, it may be necessary to remove all signs for the named route or memorial bridge along the primary highway.

e. The applicant shall be responsible for the costs to install the signs, including the posts and hardware.

f. A named route or memorial bridge shall not be given a name which could be considered discriminatory, biased or inappropriate.

**131.10(3) Memorial highway or bridge signing.** Signing for memorial highways or bridges shall comply with the MUTCD as modified by the following:

a. Memorial highway or bridge signing off the primary highway right-of-way:

(1) Preferably, signing for a memorial highway or bridge should neither appear on or along the primary highway nor be placed on bridges or other highway components. Signing is best accomplished by placing memorial plaques in

rest areas, scenic overlooks or other appropriate locations off the right-of-way where parking is provided. These plaques shall be located in a manner that will not distract motor vehicle operators.

(2) Departmental approval is not needed for memorial highway or bridge signing placed off the right-of-way at locations not subject to control under Iowa Code chapter 306B or chapter 306C, division II.

*b.* Memorial highway or bridge signing within the primary highway right-of-way:

(1) If placement of memorial plaques off the right-of-way is not acceptable, the department may approve the installation of memorial highway or bridge signs within the right-of-way provided they are independent of other guide and directional signing and they do not adversely compromise the safety or efficiency of traffic flow.

(2) As determined by the department, a memorial highway or bridge sign within the right-of-way shall be sized based on the size of lettering required for the traffic speed and type of highway being named. The color will be white lettering on brown background, and the design must be approved by the department. If the applicant prefers the sign include a design symbolic of the group or event, instead of the name, then the sign is limited in size to no larger than 24 inches in width and 30 inches in height. The color and design must be approved by the department.

(3) The number of memorial highway signs within the right-of-way shall be limited to one sign at each end of the memorial highway and one sign when entering the corporate limits of each city through which the memorial highway passes. The number of memorial bridge signs will be limited to one sign for each direction of traffic.

**131.10(4) *Historic trail and scenic trail signing.*** The department may approve the installation of historic trail and scenic trail signing within the primary highway right-of-way. Signing for historic trails and scenic trails shall comply with the MUTCD and the following:

*a.* A sign designating a historic trail or scenic trail shall be no larger than 24 inches in width and 30 inches in height. The colors used shall be limited to white, black, brown, blue or green. The color and design must be approved by the department.

*b.* Signs designating a historic trail or scenic trail may be placed at each end of the trail, when entering the corporate limits of cities through which the trail passes, and at points where the trail direction changes.

*c.* Additional trail signs may be placed between cities along the trail. These signs when facing the same direction of travel shall be spaced at least five miles apart. An exception may be made when the trail direction changes.

*d.* A sign designating a historic trail or scenic trail shall be placed alone on a post.

**131.10(5) *Procedures.***

*a.* To request placement of signs designating a primary highway or bridge as a named route or memorial bridge, the applicant shall submit a formal written request to the appropriate district office.

*b.* The request shall contain the following:

(1) A detailed description of the proposed named route or memorial bridge, including those portions of the route off the primary highway system.

(2) If the request is for a memorial highway or bridge, documentation supporting the significance of the person, group, place or event for which the memorial highway or bridge is named. Any person being honored must have provided extraordinary public service or some exemplary contribution to the public good or outstanding service to the nation, this state or the person's community and have a connection to the community where the highway or bridge is located. The person being honored must be deceased for one year.

(3) If the request is for a historic trail, documentation supporting the historical significance of the trail.

(4) If the request is for a scenic trail, information outlining the features or facilities that are of special scenic or recreational appeal.

(5) A sketch of the sign proposed for designating the named route.

(6) Proposed locations for placement of the signs, including those locations off the primary highway system.

(7) A signed resolution from each city and county through which the named route passes or where the bridge is located, indicating support of the route designation.

*c.* The department shall evaluate the request against the requirements of this rule and notify the requester of approval or denial of the request. Notification of denial shall include the reasons for denial.

*d.* The department shall install approved signs provided by the applicant (see paragraph 131.10(2)“*d*”) and provide routine maintenance when the signs are to be located within the primary highway right-of-way. The applicant shall be responsible for the installation costs for each of the signs.

*e.* The department is not responsible for the installation or maintenance of signs placed off the right-of-way or placed on the city or county highways.

[ARC 1986C, IAB 5/13/15, effective 6/17/15]

**761—131.11(314) Signing for Iowa medal of honor highway.** This rule establishes the procedures and requirements for private entities to purchase and pay for the installation of signs designating the Iowa medal of honor highway.

**131.11(1) Definition.** “Iowa medal of honor highway” means the segment of the highway known as United States Highway 20, as designated as of June 17, 2020, which crosses this state from Sioux City to Dubuque.

**131.11(2) Requirements.**

*a.* The number of signs within the highway right-of-way shall be limited to one sign at each end of the Iowa medal of honor highway for traffic entering the state and one sign at each entry point of the corporate limits of each city through which the Iowa medal of honor highway passes.

*b.* Each sign shall match the design approved and provided by the department, and the sign materials shall comply with departmental standard specifications as they exist at the time of fabrication. The departmental standard specifications can be found through the department’s electronic reference library available on the department’s website at [www.iowadot.gov](http://www.iowadot.gov).

*c.* Once signs are installed at one of the approved locations, no additional requests will be accepted for that location. When signs have been installed at all locations identified in paragraph 131.11(2) “a,” no further requests will be accepted.

*d.* The applicant may purchase a sign from the department’s sign shop or any other private sign shop. If an applicant chooses to obtain a sign from a private sign shop, the department will furnish the sign design and approve the construction prior to purchase. The department will also inspect the sign as stated in subrule 131.11(5).

*e.* Signs designating the Iowa medal of honor highway shall be furnished and paid for by the applicants, including any replacements needed due to sign deterioration or damage. The applicant is responsible for providing the traffic and safety bureau with the applicant’s current contact information so the applicant can be contacted when a replacement sign is needed. Failure to comply with this requirement may result in removal of all signs the applicant purchased. This would allow a new private entity to sponsor the signing.

*f.* The applicant shall be responsible for the cost to install the sign, including the posts and hardware. Payment to the department must be received prior to the installation of the sign.

*g.* The department shall install the sign.

**131.11(3) Procedures.**

*a.* A written request to purchase or install a sign shall be submitted to the traffic and safety bureau.

*b.* The request shall contain the following:

- (1) The applicant’s name and contact information.
- (2) A description of the location where the sign is to be installed.
- (3) If the sign will be purchased from the department or a private sign shop.

**131.11(4) Approval.** If the request complies with this rule, the traffic and safety bureau shall respond to the applicant with approval of the proposed location or modified location and an estimate of the costs for the sign and installation. Following inspection of the sign in compliance with subrule 131.11(5) and receipt of payment, the department shall install the sign.

**131.11(5) Inspection.** If a sign is not purchased from the department sign shop, the applicant shall deliver the sign to the department sign shop for inspection. Upon receipt of the sign, the department shall inspect the sign for compliance with the approved sign design and departmental specifications and notify the applicant.

[ARC 5426C, IAB 2/10/21, effective 3/17/21]

**761—131.12 to 131.14** Reserved.

**761—131.15(321) Information and address.** Information regarding the signing addressed in this chapter is available from: Traffic and Safety Bureau, Iowa Department of Transportation, 800 Lincoln Way, Ames, Iowa 50010. Submissions to the traffic and safety bureau shall also be sent or delivered to this address.

[ARC 5426C, IAB 2/10/21, effective 3/17/21]

These rules are intended to implement Iowa Code sections 314.31, 321.252 and 321.253.

[Filed July 1, 1975]

[Filed without Notice 11/23/76—published 12/15/76, effective 1/19/77]

[Filed 2/11/77, Notice 12/29/76—published 3/9/77, effective 4/13/77]

[Filed emergency 4/26/77—published 5/18/77, effective 5/18/77]

[Filed without Notice 11/21/77—published 12/14/77, effective 1/18/78]

[Filed 5/11/87, Notice 3/11/87—published 6/3/87, effective 7/8/87]

[Filed emergency 7/13/88—published 8/10/88, effective 7/13/88]

[Filed 4/3/91, Notice 2/20/91—published 5/1/91, effective 6/5/91]

[Filed 10/4/96, Notice 7/31/96—published 10/23/96, effective 11/27/96]

[Filed 10/10/02, Notice 8/7/02—published 10/30/02, effective 12/4/02]

[Filed 9/16/03, Notice 7/9/03—published 10/15/03, effective 11/19/03]

[Filed ARC 1986C (Notice ARC 1885C, IAB 2/18/15), IAB 5/13/15, effective 6/17/15]

[Filed ARC 5426C (Notice ARC 5290C, IAB 12/2/20), IAB 2/10/21, effective 3/17/21]



CHAPTER 132  
IOWA BYWAYS PROGRAM  
Rescinded **ARC 8243C**, IAB 10/2/24, effective 11/6/24

CHAPTERS 133 and 134  
Reserved



CHAPTER 135  
WARNING LIGHTS ON VEHICLES OR EQUIPMENT NOT OWNED AND OPERATED BY THE  
DEPARTMENT WHEN USED IN ROAD WORK ZONES

**761—135.1(321) Warning lights on vehicles or equipment in road work zones.**

**135.1(1) Purpose.** The purpose of this rule is to establish the eligibility of vehicles or equipment that are not owned or operated by the department to use flashing white lights in accordance with Iowa Code section 321.423(7) "a."

**135.1(2) Eligibility.** A vehicle or other equipment that is not owned or operated by the department may use a flashing white light while the vehicle or other equipment is being used in road work zones on state or local highways.

**135.1(3) Information.** Information regarding this rule is available from the Construction and Materials Bureau, Iowa Department of Transportation, 800 Lincoln Way, Ames, Iowa 50010; or by telephone at (515)239-1352.

[ARC 6132C, IAB 1/12/22, effective 2/16/22]

This rule is intended to implement Iowa Code section 321.423(7) "a."

[Filed ARC 6132C (Notice ARC 6014C, IAB 11/3/21), IAB 1/12/22, effective 2/16/22]



CHAPTER 136  
LIGHTING

[Prior to 6/3/87, Transportation Department[820]—(06,K) Ch 4]

**761—136.1(306,318) Lighting of primary-secondary intersections.** The purpose of this rule is to establish the qualification criteria for, the procedures to request, and the financial responsibilities for the placement of roadway luminaires within the limits of the primary road right-of-way at a rural intersection of a primary road and a paved secondary road.

**136.1(1) Lighting criteria.** A primary-secondary intersection is a candidate for lighting if one of the following is met:

*a.* The night-to-day accident rate ratio is 2.0 or greater with a minimum of three reportable nighttime accidents in a 12-month period.

*b.* Substantial lighted commercial or business development that is affecting operations exists adjacent to the intersection.

*c.* Motorists are experiencing operational problems which might be expected to be reduced by lighting.

*d.* The current average daily traffic (ADT) is 3500 entering vehicles for the intersection and:

(1) The intersection is channelized or "T," or

(2) A change in the direction of the major route occurs.

**136.1(2) Reserved.**

**136.1(3) Procedures.**

*a.* A request for lighting shall be made by the county to the appropriate district engineer. The request shall indicate the type and size of luminaires proposed, sight distance measurements and posted speed. If the county is requesting that the department participate in the installation costs as a C-STEP (County-State Traffic Engineering Program) project, this should be indicated in the request. A lighting plan shall accompany the request showing:

(1) The complete dimensions of the intersection including pavement and shoulders.

(2) The locations of proposed luminaires and poles.

(3) The mounting heights, mast arm lengths, lateral and vertical light distributions of proposed luminaires and the approximate location for electrical service.

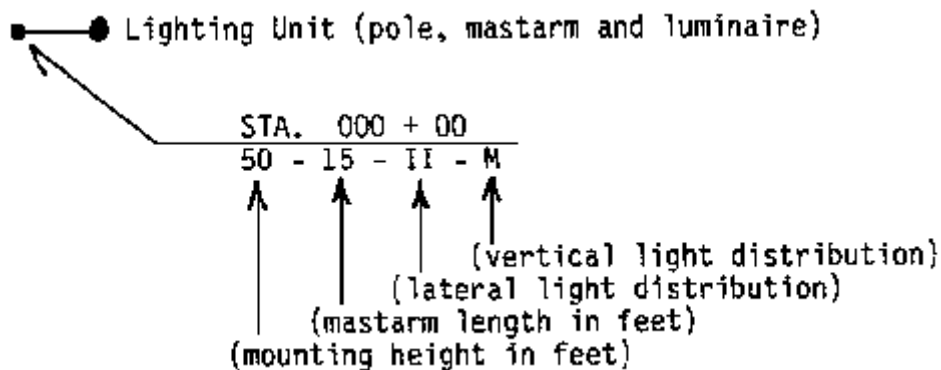

*b.* The district engineer shall forward the request to the department's traffic and safety bureau for review.

*c.* If design requirements are satisfied, the department shall approve the lighting installation.

(1) The county shall be responsible for designing and installing the lighting and for all future energy and maintenance costs.

(2) If the location qualifies for lighting installation and if funds are available, the department shall share the installation costs on the basis of the current C-STEP participation ratio.

(3) If the department does not share the installation costs but the county wishes to install the lighting, the county shall be responsible for the installation costs.

*d.* If the department will share the installation costs, the department shall prepare an agreement for departmental and county approval.

This rule is intended to implement Iowa Code sections 306.4(1), 318.1, 318.2, 318.4, 318.5, 318.8, 318.9 and 318.12.

[ARC 5492C, IAB 3/10/21, effective 4/14/21]

**761—136.2(306,318) Destination lighting.** The purpose of this rule is to establish the application procedure and financial responsibilities for the placement of a roadway luminaire within the limits of primary road right-of-way at a rural intersection of a primary road and a minor road.

**136.2(1) Definition.**

“*Minor road*,” for the purposes of this rule, is an entrance to a primary road from a frontage road, a rural commercial establishment, a governmental agency facility, a generator of a substantial traffic volume, or a secondary road.

**136.2(2) Reserved.**

**136.2(3) Procedures.**

*a.* Application shall be made to the appropriate district engineer on Form 810025, “Application and Agreement for Use of Highway Right-of-Way for Utilities Accommodation.” Form 810025 is available on the department’s website at [www.iowadot.gov](http://www.iowadot.gov). The application shall indicate the type of luminaire and intensity of illumination proposed. A sketch shall accompany the application showing the location of the proposed luminaire and pole and the mounting height of the luminaire.

*b.* The district engineer shall be responsible for departmental approval of the application. A copy of the application indicating the district engineer’s determination shall be returned to the applicant. Approved applications are termed “permits.”

*c.* The applicant shall be responsible for installing the lighting and for all installation, energy and maintenance costs.

This rule is intended to implement Iowa Code sections 306.4(1), 318.1, 318.2, 318.4, 318.5, 318.8, 318.9 and 318.12.

[ARC 5492C, IAB 3/10/21, effective 4/14/21]

**761—136.3 to 136.5** Reserved.

**761—136.6(306,318) Warrants and design requirements for lighting.**

**136.6(1) Warrants.** Meeting departmental warrants or criteria for lighting simply establishes the location as a candidate for lighting. It does not obligate the department to provide lighting or to participate in lighting costs.

**136.6(2) Design requirements.** The design of lighting installations shall comply with departmental specifications and standard road plans for highway lighting as they exist at the time of installation of the lighting. The departmental specifications and standard road plans can be found through the department’s electronic reference library on the department’s website.

This rule is intended to implement Iowa Code sections 306.4(1), 318.1, 318.2, 318.4, 318.8 and 318.9.

[ARC 5492C, IAB 3/10/21, effective 4/14/21]

[Filed 7/1/75]

[Filed 3/12/79, Notice 1/24/79—published 4/4/79, effective 5/9/79]

[Filed 12/10/86, Notice 10/8/86—published 12/31/86, effective 2/4/87]

[Filed 5/11/87, Notice 3/11/87—published 6/3/87, effective 7/8/87]

[Filed 8/26/88, Notice 7/13/88—published 9/21/88, effective 10/26/88]

[Filed 8/7/02, Notice 6/26/02—published 9/4/02, effective 10/9/02]

[Filed ARC 5492C (Notice ARC 5341C, IAB 12/30/20), IAB 3/10/21, effective 4/14/21]

CHAPTERS 137 to 139  
Reserved



CHAPTER 140  
TRAFFIC SIGNALS AND BEACONS  
ON PRIMARY ROADS

[Prior to 6/3/87, Transportation Department[820]—(06,K) Ch 5]

**761—140.1(321) Erection of traffic signals and beacons on primary highways.** The purpose of this rule is to establish requirements, procedures and responsibilities for the erection of traffic signals and beacons on primary highways.

**140.1(1) Requirements.** Traffic signals or beacons shall not be installed unless the guidelines in Part 4 of the “Manual on Uniform Traffic Control Devices,” as adopted in rule 761—130.1(321), apply.

**140.1(2) Procedure.**

*a.* All requests are to be submitted to the appropriate district office.

*b.* The applicant shall be informed of the final disposition of the request.

**140.1(3) Responsibilities.** The applicant is responsible for the installation and maintenance of these traffic control devices.

**140.1(4) Information.** Information regarding this rule is available from the Office of Traffic and Safety, Iowa Department of Transportation, 800 Lincoln Way, Ames, Iowa 50010.

This rule is intended to implement Iowa Code section 321.252.

[Filed 7/1/75]

[Filed without Notice 11/23/76—published 12/15/76, effective 1/19/77]

[Filed without Notice 11/21/77—published 12/14/77, effective 1/18/78]

[Filed 5/11/87, Notice 3/11/87—published 6/3/87, effective 7/8/87]

[Filed 10/10/02, Notice 8/7/02—published 10/30/02, effective 12/4/02]



CHAPTER 141  
TRAFFIC AND ENGINEERING INVESTIGATIONS ON  
SECONDARY ROADS

[Prior to 6/3/87, Transportation Department[820]—(06,K) Ch 6]  
Rescinded IAB 5/5/99, effective 6/9/99



CHAPTER 142  
SPEED ZONING ON PRIMARY HIGHWAYS

[Prior to 6/3/87, Transportation Department[820]—(06,K) Ch 7]

**761—142.1(321) Adjustment of speed zones on primary highways.** The purpose of this rule is to establish the procedure for processing requests to change posted speed limits on primary highways.

**142.1(1) Procedure.**

*a.* All requests for raising or lowering the posted speed limits on primary highways shall be made to the appropriate district office.

*b.* The department will conduct an engineering and traffic investigation and, if the speed limit is found to be greater or less than is reasonable or safe under the conditions found to exist, the department will declare a reasonable and proper speed limit and post appropriate signs.

*c.* The person or agency submitting the request for the engineering and traffic investigation shall be advised of the conclusions of the study and the action to be taken by the department.

**142.1(2) Information.** Information regarding this rule is available from the Traffic and Safety Bureau, Iowa Department of Transportation, 800 Lincoln Way, Ames, Iowa 50010.

This rule is intended to implement Iowa Code sections 321.285 and 321.290.

[Editorial change: IAC Supplement 2/24/21]

[Filed 7/1/75]

[Filed 5/11/87, Notice 3/11/87—published 6/3/87, effective 7/8/87]

[Filed 10/10/02, Notice 8/7/02—published 10/30/02, effective 12/4/02]

[Editorial change: IAC Supplement 2/24/21]



CHAPTER 143  
TRAFFIC SIGNAL SYNCHRONIZATION

**761—143.1(364) Definitions.** The following definitions apply to these rules:

“*Arterial street*” means any U.S. or state numbered route, controlled access highway, or other major street or highway designated by the city within its respective jurisdiction as a part of a major arterial system of streets or highways.

“*Controller*” means a supervisory device that controls the sequence and duration of indications displayed by traffic signals.

“*Coordination*” means the establishment of a definite timing relationship between adjacent traffic signals.

“*Cycle*” means any complete sequence of traffic signal indications (phases).

“*Detector*” means a device that senses vehicular or pedestrian demand and transmits an impulse to a controller.

“*Local controller*” means a controller supervising the operation of traffic signals at a single or two closely spaced intersections.

“*Master controller*” means a controller supervising the operation of several local controllers.

“*Phase*” means a portion of the cycle during which an assignment of right-of-way is made to a traffic movement or combination of traffic movements.

“*Traffic signal*” means any permanently installed, electrically powered traffic control device by which traffic is alternately directed to stop and to proceed.

“*Traffic signal system*” means two or more traffic signals operating in a coordinated manner. Types of coordinated systems:

1. “*Adaptive signal control system*” means a system in which traffic signals across a signal network are coordinated by adjusting the lengths of signal phases based on prevailing traffic conditions.

2. “*Computerized system*” means a system in which controllers are supervised by a computer.

3. “*Interconnected master-controlled system*” means a system in which local controllers are supervised by a master controller through a communications link (wire/radio). The master establishes a base line condition; the local then operates its intersection in a predetermined relationship with the base line.

4. “*Noninterconnected system*” means a system in which timing relationships between individual local controllers are coordinated by manual settings, without physical interconnection between the controllers.

5. “*Time-based coordinated system*” means a noninterconnected system in which the local controllers use a programmable digital timing and control device (time-based coordinator) to maintain coordination.

6. “*Traffic responsive system*” means a system in which a master controller specifies cycle timings based on the real time demands of traffic as sensed by vehicle detectors.

[ARC 2984C, IAB 3/15/17, effective 4/19/17]

**761—143.2(364) Applicability.** This chapter applies to all cities with more than three traffic signals within the corporate limits.

**761—143.3(364) Traffic signal inventory.** Rescinded IAB 9/4/02, effective 10/9/02.

**761—143.4(364) Required synchronization.**

**143.4(1)** Unless a traffic engineering study documents that it is not practical, traffic signals within one-half mile of each other along an arterial street or in a network of intersecting arterial streets shall be operated as a traffic signal system.

**143.4(2)** Reserved.

**143.4(3)** Timing and operational plans developed for traffic signals shall be developed by application of traffic engineering principles to provide maximum traffic flow efficiencies and safety.

**143.4(4)** All traffic signal installations and operations shall meet the requirements of the “Manual on Uniform Traffic Control Devices,” as adopted in 761—Chapter 130.

[ARC 2984C, IAB 3/15/17, effective 4/19/17]

**761—143.5(364) Reporting requirements.** Rescinded IAB 9/4/02, effective 10/9/02.

This chapter is intended to implement Iowa Code section 364.24.

[Filed 3/12/90, Notice 1/24/90—published 4/4/90, effective 5/9/90]

[Filed 8/7/02, Notice 6/26/02—published 9/4/02, effective 10/9/02]

[Filed ARC 2984C (Notice ARC 2863C, IAB 12/21/16), IAB 3/15/17, effective 4/19/17]



CHAPTER 144  
AUTOMATED TRAFFIC ENFORCEMENT ON THE PRIMARY ROAD SYSTEM  
Rescinded **ARC 3998C**, IAB 9/12/18, effective 10/17/18

CHAPTERS 145 to 149  
Reserved



## PRIMARY ROAD EXTENSIONS

## CHAPTER 150

## IMPROVEMENTS AND MAINTENANCE ON PRIMARY ROAD EXTENSIONS

[Prior to 6/3/87, Transportation Department[820]—(06,L) Ch 1]

**761—150.1(306) Definitions.**

“*Access control limits*” means the area within the primary highway right-of-way limits, including right-of-way lines extended across side streets and roads. The term includes areas on side streets and roads where the department has acquired access control rights in accordance with 761—Chapter 112.

“*City*” means a municipal corporation as defined in Iowa Code section 362.2.

“*Encroachment*” means an item which is supported or located on the highway right-of-way or which overhangs into the airspace of the highway right-of-way.

“*Freeway*” means a fully controlled access primary highway. The rights of ingress and egress from abutting properties have been legally eliminated by the department. Permanent access to the freeway is allowed only at interchange locations. For the purpose of highway lighting, a freeway is generally five or more miles in length.

“*MUTCD*” means the “Manual on Uniform Traffic Control Devices,” as adopted in 761—Chapter 130.

“*Nonfreeway primary highway*” means a primary highway that is not a freeway.

“*Obstruction*” means the same as defined in Iowa Code section 318.1.

“*Right-of-way*” means the land for any public road, street or highway, including the entire area between the property lines.

“*Urban-state traffic engineering program*” or “*U-STEP*” refers to a department program that is intended for use by any Iowa city in order to solve traffic operations and safety problems on primary roads in Iowa cities as documented in the department’s “Guide to Transportation Funding Programs.”

“*Utility*” means the same as defined in Iowa Code section 306A.13.

This rule is intended to implement Iowa Code sections 306.2, 306.3, 306A.13, 318.1 and 362.2.

[ARC 3501C, IAB 12/6/17, effective 1/10/18; ARC 6562C, IAB 10/5/22, effective 11/9/22]

**761—150.2(306) Improvements and maintenance on extensions of freeways.**

**150.2(1) Construction.** Except as otherwise provided, the department shall be responsible for all right-of-way and construction costs associated with the construction of freeway extensions.

a. The city shall be responsible for providing, without cost to the department, all necessary rights-of-way that involve dedicated streets or alleys.

b. The city may be responsible for providing, without cost to the department, all necessary rights-of-way that involve other city-owned lands, except parklands, subject to the condition that the department may reimburse the city for the functional replacement value of improved property and advanced purchases negotiated by the city for project purposes.

c. Outside the access control limits, the department shall be responsible for the costs of construction of longitudinal and outlet storm sewers made necessary by highway construction in the proportion that the street right-of-way of the primary road extension bears to the total drainage area to be served by the proposed sewers. The city shall be responsible for the remaining portion of storm-sewer costs not paid for by the department.

d. The department shall be responsible for all storm sewer-related costs within the access control limits.

**150.2(2) Maintenance.** The department shall enter into an agreement with a city regarding the maintenance of primary roads within the corporate city limits. This is intended to include corporate line roads, when appropriate. Unless otherwise mutually agreed to and specified in the agreement, the maintenance of freeway extensions within the corporate city limits, including corporate line roads, shall be as follows:

a. The department shall be responsible for all maintenance costs on the through roadway, the on and off ramps, and the roadside features from right-of-way line to right-of-way line.

b. Where city streets cross the freeway, the department shall be responsible for:

- (1) Roadside maintenance within the limits of the freeway fence.
- (2) Surface drainage of the right-of-way.
- (3) Traffic signs and pavement markings required for freeway operation.
- (4) Guardrail at piers and bridge approaches.
- (5) Expansion relief joints in approach pavement and leveling of bridge approach panel(s).
- (6) All maintenance of bridges including deck repair, structural repair, berm slope protection, painting, and inspection, except as noted in paragraph “c” of this subrule.

c. Where city streets cross the freeway, the city shall be responsible for:

- (1) All roadside maintenance outside the freeway fence.
- (2) All pavement, subgrade and shoulder maintenance on the cross street except expansion relief joints and bridge approach panel leveling.
- (3) All traffic lane markings on the cross street.
- (4) Snow removal on the cross street including bridges over the freeway.
- (5) Cleaning and sweeping bridge decks on streets crossing over the freeway.
- d.* The city shall be responsible for maintenance and repair of pedestrian overpasses and underpasses including snow removal, painting, lighting and structural repairs.
- e.* Should local service roads or streets be constructed as a part of a project, upon completion they shall become a part of the city street system. The department shall not be responsible for the maintenance of these roads or streets and corresponding drainage structures.

**150.2(3) *Lighting.***

- a.* The department shall be responsible for the cost of installation of lighting on the main-traveled-way lanes and the on and off ramps including the terminals with cross streets when the department determines that lighting is required under established warrants.
- b.* The department shall be responsible for the energy and maintenance costs of lighting on the main-traveled-way lanes.
- c.* The department shall be responsible for the energy and maintenance costs of lighting through interchange areas and ramps at interchanges between freeways which do not provide service to local streets.
- d.* The department shall be responsible for the energy and maintenance costs of lighting in interchange areas at interchanges between freeways and primary roads which are on corporate lines.
- e.* At interchanges with city cross streets, the department shall be responsible for the energy and maintenance costs of lighting on the main-traveled-way lanes, on and off ramps, ramp terminals, and, when the department determines full interchange lighting is required, the cross street between the outermost ramp terminals.
- f.* The department shall not be responsible for the installation, energy, and maintenance costs of any lighting on cross streets in advance of interchanges and between the outermost ramp terminals at interchanges where the department determines partial interchange lighting or no lighting is required.
- g.* The department shall not be responsible for the installation, energy and maintenance costs of any lighting on pedestrian overpasses, pedestrian underpasses, bicycle overpasses or bicycle underpasses. The city may elect to provide lighting at its own expense.
- h.* Warrants for the lighting of freeways shall be according to the 2005 "AASHTO Roadway Lighting Design Guide."

**150.2(4) *Traffic signals at ramp terminals with cross streets.***

- a.* All traffic signal installations shall meet the standards and warrants established in the MUTCD.
- b.* On projects initiated by the department, the department may install, at no cost to the city, traffic signals warranted when replacing existing pavement or adding new lanes. In conjunction with these projects, the department may also participate in the cost of signals that are for pedestrian use only. If the department participates, the department's share of the installation costs shall be based on the current U-STEP cost apportionment.
- c.* When new pavement construction or additional lanes are not involved, the department may participate in the installation costs of new and modernized traffic signals or signals that are for pedestrian use only. If the department participates, the department's share of the installation costs shall be based on the current U-STEP cost apportionment; the city shall prepare plans, award the contract, supervise the installation, and be responsible for the remaining installation costs.
- d.* Modifications made to the traffic signal system to coordinate it with other city signal systems (not on the primary road extension system) shall be the sole financial responsibility of the city.
- e.* The department shall not assume ownership and shall not be responsible for the energy and maintenance costs involved in the operation of traffic signals.
- f.* Signal phasing, initial and future, as well as timing and coordination between intersections shall be coordinated between the department and the city.

This rule is intended to implement Iowa Code sections 306.4, 306.42, 313.4, 313.5, 313.21 to 313.24, 313.27, 313.36, 314.5 and 314.6 and chapter 306A.

[ARC 3501C, IAB 12/6/17, effective 1/10/18; ARC 5427C, IAB 2/10/21, effective 3/17/21]

**761—150.3(306) Improvements and maintenance on extensions of nonfreeway primary highways.**

**150.3(1) *Construction.***

*a.* The department shall be responsible for all right-of-way and construction costs to construct nonfreeway primary highway extensions to the minimum design criteria as established by the department. Construction improvement costs beyond minimum design criteria shall be the responsibility of the city, as specified in the project agreement. Minimum design criteria shall be in accordance with “A Policy on Geometric Design of Highways and Streets, 2018” (Seventh Edition AASHTO Green Book).

*b.* The city shall be responsible for providing, without cost to the department, all necessary rights-of-way that involve dedicated streets or alleys.

*c.* The city may be responsible for providing, without cost to the department, all necessary rights-of-way that involve other city-owned lands, except parklands, subject to the condition that the department may reimburse the city for the functional replacement value of improved property and advanced purchases negotiated by the city for project purposes.

*d.* The city shall take all necessary legal action to discontinue and prohibit any past or present use of project rights-of-way for private purposes. The city shall prevent any future encroachment or obstruction within the limits of project rights-of-way.

*e.* The department shall be responsible for the costs of construction of longitudinal and outlet storm sewers made necessary by highway construction and construction of local service roads developed as a part of the construction or reconstruction of the through traffic lanes in the proportion that the right-of-way of the primary road extension bears to the total drainage area to be served by the proposed sewers. The city shall be responsible for the remaining portion of storm-sewer costs not paid for by the department.

*f.* Unless otherwise mutually agreed to and specified in the project agreement, the department shall be responsible for the cost of acquiring rights-of-way and construction of local service roads developed as a part of the construction or reconstruction of the through traffic lanes.

**150.3(2) Maintenance.** The department shall enter into an agreement with a city regarding the maintenance of primary roads within the corporate city limits. This is intended to include corporate line roads, when appropriate. Unless otherwise mutually agreed to and specified in the agreement, the maintenance of nonfreeway primary highway extensions within the corporate city limits, including corporate line roads, shall be as follows:

*a.* On primary roads constructed with a curbed cross section, the department shall be responsible for:

(1) Maintenance and repairs to pavement and subgrade from face of curb to face of curb exclusive of parking lanes, culverts, intakes, manholes, public or private utilities, sanitary sewers and storm sewers.

(2) Primary road signing for moving traffic as set out in subrule 150.4(1), pavement markings for traffic lanes, guardrail and stop signs at intersecting streets.

(3) Surface drainage only, within the limits of pavement maintenance.

(4) Plowing of snow from the traffic lanes of pavement and bridges and treatment of traffic lanes with abrasives and chemicals.

(5) Inspection, painting and structural maintenance of bridges as defined in Iowa Code section 309.1.

*b.* On primary roads constructed with a rural cross section (no curb), the department shall be responsible for all maintenance, except tree removal, sidewalks, retaining walls and repairs due to utility construction and maintenance shall be the city's responsibility.

*c.* On primary roads constructed with a curbed cross section, the city shall be responsible for:

(1) Maintenance and repairs to pavement in parking lanes, intersections beyond the limits of department pavement maintenance, curbs used to contain drainage, and repairs to all pavement due to utility construction, maintenance and repair.

(2) Painting of parking stalls, stop lines and crosswalks, and the installation and maintenance of flashing lights. Pavement markings shall conform to the MUTCD.

(3) Maintenance of all storm sewers, manholes, intakes, catch basins and culverts used for collection and disposal of surface drainage.

(4) Removal of snow windrowed by departmental plowing operations, removal of snow and ice from all areas outside the traffic lanes, loading or hauling of snow which the city considers necessary and removal of snow and ice from sidewalks on bridges used for pedestrian traffic.

(5) Maintenance of sidewalks, retaining walls and all areas between curb and right-of-way line.

(6) Cleaning, sweeping and washing of streets.

(7) Maintenance and repair of pedestrian overpasses and underpasses including snow removal, painting and structural repairs.

(8) Maintenance and repair of bicycle overpasses and underpasses including snow removal, painting and structural repairs.

d. The city shall comply with the access control policy of the department as adopted in 761—Chapter 112 and obtain prior approval from the department for any changes to existing entrances or for the construction of new entrances.

e. Drainage district assessments levied against the primary road within the corporate limits of the city shall be shared equally by the department and the city.

f. Should local service roads or streets be constructed as a part of a project, upon completion they shall become a part of the city street system. The department shall not be responsible for the maintenance of these roads or streets and corresponding drainage structures.

**150.3(3) Lighting.**

a. The department shall not be responsible for the installation, energy, and maintenance costs of lighting on extensions of nonfreeway primary highways. The city may elect to provide lighting at its own expense. However:

(1) For cities with a population of 5,000 or less, the department may elect to install interchange lighting and to be responsible for or to participate in the energy and maintenance costs of this lighting.

(2) On a new construction project that results in a predominately fully controlled access highway, but incorporates some nonfreeway segments, the department may elect to participate in the installation of lighting at conflict points if the city agrees to be responsible for the energy and maintenance costs of this lighting.

b. At corporate line primary road junctions, the lighting shall be installed where necessary by the department in accordance with department warrants. The department shall be responsible for the installation costs. Unless otherwise agreed, the energy and maintenance costs shall be shared by the city and department in proportion to the number of luminaires in each jurisdiction as established by the corporate line. When and if the corporate line is extended to include any part of the lighting installation or a greater proportion of luminaires, the proportionate costs for maintenance and energy shall be redetermined on the basis of the number of luminaires in each jurisdiction as established by the new location of the corporate line.

**150.3(4) Traffic signals.**

a. All traffic signal installations shall meet the standards and warrants established in the MUTCD.

b. On projects initiated by the department, the department may install, at no cost to the city, traffic signals warranted when replacing existing pavement or adding new lanes. In conjunction with these projects, the department may also participate in the cost of signals that are for pedestrian use only. If the department participates, the department's share of the installation costs shall be based on the current U-STEP cost apportionment.

c. When new pavement construction or additional lanes are not involved, the department may participate in the installation costs of new and modernized traffic signals or signals that are for pedestrian use only. If the department participates, the department's share of the installation costs shall be based on the current U-STEP cost apportionment; the city shall prepare plans, award the contract, supervise the installation, and be responsible for the remaining installation costs.

d. Modifications made to the traffic signal system to coordinate it with other city signal systems (not on the primary road extension system) shall be the sole financial responsibility of the city.

e. The department shall not participate in the cost of signals for commercial use only.

f. The department shall not participate in the signalization of primary road stub routes which terminate within the city.

g. The department shall not assume ownership and shall not be responsible for any energy or maintenance costs for traffic signals.

h. Signal phasing, initial and future, as well as timing and coordination between intersections shall be coordinated between the department and the city.

**150.3(5) Overdimensional and overweight vehicles.** The city shall comply with all current statutes, rules and regulations pertaining to overdimensional and overweight vehicles using primary roads when issuing special permits for overdimensional and overweight vehicles.

This rule is intended to implement Iowa Code sections 306.4, 306.42, 313.5, 313.21 to 313.24, 313.27, 313.36, 314.5, 314.6 and 321E.3 and chapter 306A.

[ARC 3501C, IAB 12/6/17, effective 1/10/18; ARC 5427C, IAB 2/10/21, effective 3/17/21]

**761—150.4(306) General requirements for primary road extensions.**

**150.4(1) Signing.**

a. The department shall be responsible for permanent traffic control signing on primary road extensions.

b. The department shall not be responsible for construction and maintenance work zone signing unless the work is being done by the department.

c. The department shall not be responsible for street name signs, any regulatory parking signs which denote special regulations as may be determined by the city in cooperation with the department, and those signs which regulate parking as to time, hours and days of the week.

d. The department shall not be responsible for signs facing traffic on primary road extensions which regulate traffic movements on city cross streets (one-way traffic).

e. "Business District" signs on primary road extensions may be permitted upon application by the city to the department.

f. All signing within the right-of-way shall conform to the MUTCD.

**150.4(2) Encroachments and obstructions.**

a. The city shall remove any existing obstructions within the highway right-of-way and prevent any future obstructions from occurring within the highway right-of-way, in a manner consistent with Iowa Code chapter 318.

b. The city shall remove any existing encroachments and prevent any future encroachments from occurring within the highway right-of-way, except those authorized or permitted by the highway authority. Under no circumstances shall an overhanging sign or awning be allowed within two feet of the inside edge of the curb (also known as the face of the curb, which is that part of the curb that is next to traffic) or within two feet of the edge of the pavement in the absence of a curb. Any encroachments authorized or permitted by the highway authority shall be in accordance with Iowa Code chapter 318.

**150.4(3) Pedestrian, equestrian, and bicycle routes (sidewalks).**

a. The department shall remove and replace portions of existing routes as required by construction.

b. The department will consider the impacts to pedestrian accommodation at all stages of the project development process and encourage pedestrian accommodation efforts when pedestrian accommodation is impacted by highway construction. The cost of pedestrian accommodation made at the time of the highway improvement may be considered an additional roadway construction cost. Providing pedestrian accommodation independent of a highway construction project may be considered with construction funding obtained from local jurisdictions or other federal and non-road use tax state sources.

c. If a project is initiated by the department, the department shall fund 100 percent of all curb ramps, turning spaces, transitions, sidewalks, curb drops and pedestrian signals within the right-of-way of primary road extensions to meet the requirements of the Americans with Disabilities Act if such improvements are in the project.

d. If a project is initiated by a local jurisdiction, the department may participate by funding 55 percent of the cost of constructing curb ramps, turning spaces, transitions, sidewalks, curb drops and pedestrian signals on existing sidewalks within the right-of-way of primary road extensions to meet the requirements of the Americans with Disabilities Act if such improvements are in the project. However, departmental participation shall not exceed \$250,000 per year for any one local jurisdiction and \$5 million per year in total.

**150.4(4) Overpasses and underpasses for pedestrian, equestrian, and bicycle routes.**

a. During initial construction of freeways and other relocated primary road extensions and when user-volumes and topographic conditions warrant the construction of a separation, the cost shall be shared between the department and the city on the basis of the current U-STEP cost apportionment.

b. The department may participate in a city-initiated separation as an unscheduled project.

**150.4(5) Utility relocation and removal.**

a. The city shall relocate or cause to be relocated, without cost to the department, all city-owned utilities necessary for construction when these utilities are within the existing street or alley right-of-way. The department shall reimburse the owner of a utility which is located on private right-of-way for the costs of relocation or removal, including the costs of installation in a new location.

b. The city shall comply with the utility accommodation policy of the department, as adopted in 761—Chapter 115.

**150.4(6) Project concept statements and predesign project agreements for proposed construction projects.**

a. As early as possible after an urban project is included in the department's "Five-Year Iowa Transportation Improvement Program," a concept statement for the project shall be developed and shall be reviewed with the officials of the city prior to the public hearing.

b. During the design process, a predesign project agreement may be submitted to city officials for their approval. It shall include:

- (1) A preliminary description of the project,
- (2) The general concepts of the project,
- (3) Responsibilities for right-of-way acquisition, storm sewer costs and utility adjustment costs,
- (4) The parking and access control restrictions to be applied to the project, and
- (5) Financial participation above minimum standards.

**150.4(7)** *Preconstruction project agreements for proposed construction projects.*

*a.* The department shall maintain a close liaison with the city during the development of the project plan so that all parties will be fully informed of the details involved in the proposed improvement.

*b.* When the plan is sufficiently complete to provide typical cross sections, plan and profile drawings and incidental details, the department shall submit a preconstruction project agreement, which shall include known design data, to city officials for their approval. Terms for reimbursement to the state and local financial participation shall be stated in this agreement.

*c.* Modifications to this agreement necessitated by design changes encountered during construction shall be made by extra work order agreed to in writing by the city, the contractor, and the department.

This rule is intended to implement Iowa Code sections 306.4, 313.21 to 313.24, 313.27, 313.36, 314.5 and 314.6 and chapters 306A and 318.

[ARC 0478C, IAB 12/12/12, effective 1/16/13; ARC 3501C, IAB 12/6/17, effective 1/10/18]

**761—150.5(307) Special circumstances.**

**150.5(1)** *Waivers.* The director of transportation may, in response to a written petition, waive provisions of this chapter in accordance with 761—Chapter 11. The written petition must contain the information as required in 761—subrule 11.5(2) and shall be submitted to the Rules Administrator, Government and Community Relations, Iowa Department of Transportation, 800 Lincoln Way, Ames, Iowa 50010; or by email to the rules administrator's email address listed on the department's website at [iowadot.gov/administrativerules](http://iowadot.gov/administrativerules).

**150.5(2)** *Waivers involving interstate highways.* The director of transportation shall not waive these rules if the request involves the interstate highway system, including its ramps, without the approval of the Federal Highway Administration.

This rule is intended to implement Iowa Code sections 17A.9A and 307.12.

[ARC 3501C, IAB 12/6/17, effective 1/10/18; ARC 5427C, IAB 2/10/21, effective 3/17/21; Editorial change: IAC Supplement 7/28/21]

[Filed 7/1/75]

[Filed 4/4/85, Notice 2/13/85—published 4/24/85, effective 5/29/85]

[Filed emergency 7/18/85—published 8/14/85, effective 7/19/85]

[Filed 5/11/87, Notice 3/11/87—published 6/3/87, effective 7/8/87]

[Filed emergency 8/26/88 after Notice of 7/13/88—published 9/21/88, effective 8/26/88]

[Filed 5/19/89, Notice 4/5/89—published 6/14/89, effective 7/19/89]

[Filed emergency 4/17/96 after Notice 3/13/96—published 5/8/96, effective 4/18/96]

[Filed 7/20/00, Notice 5/17/00—published 8/9/00, effective 9/13/00]

[Filed 9/10/02, Notice 7/10/02—published 10/2/02, effective 11/6/02]

[Filed ARC 0478C (Notice ARC 0333C, IAB 9/19/12), IAB 12/12/12, effective 1/16/13]

[Filed ARC 3501C (Notice ARC 3367C, IAB 10/11/17), IAB 12/6/17, effective 1/10/18]

[Filed ARC 5427C (Notice ARC 5244C, IAB 11/4/20), IAB 2/10/21, effective 3/17/21]

[Editorial change: IAC Supplement 7/28/21]

[Filed ARC 6562C (Notice ARC 6434C, IAB 7/27/22), IAB 10/5/22, effective 11/9/22]

CHAPTER 151  
CITY REQUESTS FOR CLOSURE OF  
PRIMARY ROAD EXTENSIONS

[Prior to 4/24/85, (06,J) Ch 1]  
[Prior to 6/3/87, Transportation Department[820]—(06,L) Ch 2]

**761—151.1(321) Closing primary road extensions.** The purpose of this rule is to establish requirements and procedures for the closing of primary road extensions for reasons other than fire, construction or repair in accordance with Iowa Code section 321.348.

**151.1(1) Definitions.** The following terms shall have these meanings unless the context indicates a different meaning.

“*Adequate detour*” shall mean an alternate route which, based on the engineering judgment of the district engineer, has the operational capability to handle the increased traffic for the specified period of the detour.

“*Local enforcement officers*” shall mean city police, town marshals, or other entities legally granted police power for control of traffic.

“*Primary road extensions*” shall mean the extension of any primary road into or through the corporate limits of a city.

“*Primary stub*” shall mean the extension of any primary road that crosses the corporate limits and terminates at the central business district of a city.

**151.1(2) Requirements.**

*a.* Adequate detour over paved roads shall be provided with traffic controls as prescribed in the “Manual on Uniform Traffic Control Devices,” as adopted in rule 761—130.1(321). City officials shall secure the written approval of the county board of supervisors to use any county road as a detour.

*b.* The city shall be responsible for maintenance and restoration of the detour, and shall accept responsibility for any damages that may occur to the closed section of the primary extension. The city shall accept full liability for conditions and operations of the detour.

*c.* The closed streets shall be used only for a civic purpose; no closing for promotion of commercial activities shall be allowed.

*d.* The benefit to the community must outweigh the temporary inconvenience to motorists.

*e.* The city shall request the Iowa state patrol to review the proposed detour for safety. During use, traffic shall be policed by local enforcement officers.

**151.1(3) Arterial system.** Rescinded IAB 4/3/02, effective 5/8/02.

**151.1(4) Arterial connector system.** Rescinded IAB 4/3/02, effective 5/8/02.

**151.1(5) Procedures.** Procedures for closing primary road extensions shall be as follows:

*a.* Cities shall file a “Request for Closing Primary Road Extension,” Form 810030, available from district offices. The request shall include the name of the city, period that the covered route is to be closed, the precise section involved, the proposed detour and the purpose for the closure. If the proposed detour involves any part of a county road, the written approval of the county board of supervisors must be submitted with the request.

*b.* The request shall be signed by the city officials, be reviewed by the Iowa state patrol, and submitted to the district engineer 45 days prior to the first day of closure. The department shall respond to the city in 20 days from the date the request is received. If all requirements in this rule are met, the department may approve the request.

*c.* The department shall erect any necessary signs on the detour.

**151.1(6) Primary stub routes.** The city may close a section of a primary stub route for a municipal celebration without obtaining department approval if substitute traffic arrangements are provided. The requirements set out in subrules 151.1(2) to 151.1(5) shall not apply.

This rule is intended to implement Iowa Code section 321.348.

[Editorial change: IAC Supplement 8/11/21]

[Filed 7/22/77, Notice 5/4/77—published 8/10/77, effective 9/14/77]

[Filed 4/4/85, Notice 2/13/85—published 4/24/85, effective 5/29/85]

[Filed 8/28/86, Notice 7/16/86—published 9/24/86, effective 10/29/86]

[Filed 5/11/87, Notice 3/11/87—published 6/3/87, effective 7/8/87]

[Filed 3/13/02, Notice 2/6/02—published 4/3/02, effective 5/8/02]

[Editorial change: IAC Supplement 8/11/21]



CHAPTERS 152 to 159  
Reserved



*SPECIAL HIGHWAY PROGRAMS*

## CHAPTER 160

## COUNTY AND CITY BRIDGE CONSTRUCTION FUNDS

Note: 761—Ch 160, Special Great River Road Fund, rescinded IAB 3/7/90, effective 4/11/90

**761—160.1(312) Purpose.** The purpose of these rules is to establish requirements for the counties' and cities' bridge construction funds, in accordance with Iowa Code section 312.2.

[ARC 2425C, IAB 3/2/16, effective 4/6/16]

**761—160.2(312) Contact information.** Questions regarding this chapter may be directed to the Office of Local Systems, Iowa Department of Transportation, 800 Lincoln Way, Ames, Iowa 50010.

[ARC 2425C, IAB 3/2/16, effective 4/6/16]

**761—160.3(312) Source of funds.** Iowa Code section 312.2 provides for yearly credits from the road use tax fund of \$2 million to the county bridge construction fund and \$500,000 to the city bridge construction fund.

[ARC 2425C, IAB 3/2/16, effective 4/6/16]

**761—160.4(312) Administration of funds.** The department shall allocate the funds to counties and cities for bridge construction and reconstruction projects based on needs. The funds shall be administered by the department's office of local systems.

**160.4(1)** The county bridge construction fund shall be allocated for projects on secondary roads as determined by the department after consultation with county officials through their representative organizations.

**160.4(2)** The city bridge construction fund shall be allocated for projects on city streets as determined by the department after consultation with city officials through their representative organizations.

**160.4(3)** To be considered for funding, a proposed project must be on the appropriate eligibility list maintained by the department.

*a.* The department shall maintain a county bridge construction fund eligibility list and a city bridge construction fund eligibility list.

*b.* A local jurisdiction may propose a project by submitting a project application to the office of local systems.

*c.* Unless otherwise agreed to by the city and county, a proposed project for a bridge located on the line dividing incorporated and unincorporated areas shall be placed on the eligibility list that corresponds to the jurisdiction submitting the application.

**160.4(4)** Prior to allocation, the department shall rank the proposed projects within each eligibility list by a priority system based on needs, as developed under subrules 160.4(1) and 160.4(2). The priority system will include various items such as, but not limited to, structural condition, traffic, and detour length. For each list, the department shall allocate funds, within the limits of funding availability, to those projects ranked as having the greatest needs.

[ARC 2425C, IAB 3/2/16, effective 4/6/16]

These rules are intended to implement Iowa Code section 312.2.

[Filed 2/7/90, Notice 12/27/89—published 3/7/90, effective 4/11/90]

[Filed 8/7/02, Notice 6/26/02—published 9/4/02, effective 10/9/02]

[Filed ARC 2425C (Notice ARC 2319C, IAB 12/23/15), IAB 3/2/16, effective 4/6/16]



CHAPTER 161  
HIGHWAY BRIDGE PROGRAM FOR CITIES AND COUNTIES  
[Prior to 6/3/87, Transportation Department[820]—(06,Q) Ch 8]  
Rescinded **ARC 8243C**, IAB 10/2/24, effective 11/6/24



CHAPTER 162  
SURFACE TRANSPORTATION BLOCK GRANT PROGRAM

**761—162.1(307) Purpose.** Federal authorization acts appropriate funds to states to support surface transportation investments. A portion of these funds are provided to the state of Iowa for the Surface Transportation Block Grant Program. The purpose of these rules is to establish requirements for the Surface Transportation Block Grant Program.

[ARC 2745C, IAB 10/12/16, effective 10/1/16; ARC 2843C, IAB 12/7/16, effective 1/11/17; ARC 3878C, IAB 7/4/18, effective 8/8/18]

**761—162.2(307) Information.** Information relating to this chapter may be obtained from Program Management, Iowa Department of Transportation, 800 Lincoln Way, Ames, Iowa 50010; telephone (515)239-1661; or on the department's website at [www.iowadot.gov](http://www.iowadot.gov).

[ARC 2745C, IAB 10/12/16, effective 10/1/16; ARC 2843C, IAB 12/7/16, effective 1/11/17; ARC 3878C, IAB 7/4/18, effective 8/8/18; Editorial change: IAC Supplement 9/21/22]

**761—162.3(307) Source of funds.** The Surface Transportation Block Grant Program established in 23 U.S.C. Section 133 provides for the use of federal funds to preserve and improve the condition and performance of any federal-aid highway, bridge or tunnel project on any public road. Surface Transportation Block Grant funds may also be used on pedestrian and bicycle infrastructure and transit capital projects including intercity bus terminals.

[ARC 2745C, IAB 10/12/16, effective 10/1/16; ARC 2843C, IAB 12/7/16, effective 1/11/17; ARC 3878C, IAB 7/4/18, effective 8/8/18]

**761—162.4(313) Swapping of funds.** Surface Transportation Block Grant funds allocated to city and county road or bridge construction projects may be swapped with primary road funds in accordance with Iowa Code section 313.4(1).

[ARC 3878C, IAB 7/4/18, effective 8/8/18]

**761—162.5(307) Administration of funds.** Surface Transportation Block Grant funds are administered by the department and shall be made available for obligation throughout the state on a fair and equitable basis. The department, in consultation with city, county and local planning agency officials, through their representative organizations, shall allocate these funds to Iowa's transportation management areas, metropolitan planning organizations, regional planning affiliations, incorporated cities, counties and the department. Allocation of these funds shall be based upon a distribution methodology approved by the commission. The commission shall review and approve the distribution methodology upon passage of each federal authorization act. Funds allocated to cities and counties to support the Federal-Aid Highway Bridge Program shall be made in accordance with 761—Chapter 161. All allocations of the Surface Transportation Block Grant funds shall be made in accordance with the Federal Highway Administration's regulations and include the allocations of the Surface Transportation Program (STP) Set-Aside for transportation alternatives as established in 23 U.S.C. Section 133(h).

[ARC 2745C, IAB 10/12/16, effective 10/1/16; ARC 2843C, IAB 12/7/16, effective 1/11/17; ARC 3878C, IAB 7/4/18, effective 8/8/18]

These rules are intended to implement Iowa Code sections 307.44 and 313.4(1).

[Filed Emergency ARC 2745C, IAB 10/12/16, effective 10/1/16]

[Filed ARC 2843C (Notice ARC 2750C, IAB 10/12/16), IAB 12/7/16, effective 1/11/17]

[Filed ARC 3878C (Notice ARC 3777C, IAB 5/9/18), IAB 7/4/18, effective 8/8/18]

[Editorial change: IAC Supplement 9/21/22]



CHAPTER 163  
RISE PROGRAM

[Prior to 6/3/87, Transportation Department[820]—(06,Q) Ch 4]

**761—163.1(315) Definitions.** When used in this chapter, unless the context otherwise requires:

“*Brownfield site*” means an abandoned, idled, or underutilized industrial or commercial facility where expansion or redevelopment is complicated by real or perceived environmental contamination.

“*Commission*” means the state transportation commission.

“*Department*” means the Iowa department of transportation.

“*Direct jobs created*” refers to jobs new to the state in firms, developments, or sites specifically assisted by a RISE project.

“*Direct jobs retained*” refers to existing Iowa jobs that would otherwise be lost in firms, developments, or sites specifically assisted by a RISE project.

“*Economic development*” means private investment involving the creation of new jobs and income or the retention of existing jobs and income that would otherwise be lost. For the purposes of this program, economic development shall be viewed from a statewide perspective rather than a local or substate, regional perspective and shall result in a net gain to the state.

“*Funding commitment*” means commission approval of the use of RISE funds for a project.

“*Grant*” means funds received for a RISE project with no provision for applicant repayment of principal.

“*Immediate opportunity project*,” one of the two types of RISE projects, is a roadway project that needs a funding commitment within a short time period and meets the threshold criteria in subrule 163.10(6). The project primarily provides improved access to a single economic unit, such as a county, a city, an industrial park, a plant or other business, a development site or a tourist attraction.

“*Import substitution*” means replacing inputs, products or services from out-of-state firms or locations with Iowa inputs, products or services.

“*Jurisdiction*” means the state, county, or city having legal authority over a road or street.

“*Loan*” means funds received for a RISE project with provision for applicant repayment of principal. A loan may or may not involve the payment of interest charges.

“*Local development project*,” one of the two types of RISE projects, is a roadway project which is programmed through a semiannual competitive rating procedure. The project primarily provides improved access to either a single economic unit, such as a county, a city, an industrial park, a plant or other business, a development site or a tourist attraction, or to a portion of a metropolitan area.

“*Project*” means an eligible activity or cost or set of eligible activities or costs funded with RISE program funds. The two types of projects which may be funded under the RISE program are immediate opportunity projects and local development projects.

“*RISE*” means revitalize Iowa’s sound economy.

“*RISE fund*” means the fund created in Iowa Code section 315.2.

“*Total capital investment*” means the economic value of all permanent purchases, donations, or improvements directly associated with an economic development activity but not funded with RISE moneys, including land; improvements to land; buildings; equipment; furnishings; electric, gas, telephone, and other utilities; sanitary sewer and storm sewer extensions and hookups; and railroad spurs, access roads, parking lots, and other transportation facilities.

“*Traffic impact analysis*” means an analysis identifying system and immediate impacts associated with a proposed development to allow an assessment of the existing and future highway system’s safety, performance, maintenance, and capacity needs and includes all necessary information as required by the department.

“*Transportation justification*” means the reasons given for a project from a transportation planning and engineering standpoint. The justification should address the current condition of existing roadways or bridges, the relationship of the project to connecting roads, anticipated total traffic, anticipated large truck traffic, proposed major design features, roadway function, and the reasons the proposed alternative was selected over other available alternatives.

“*Value-adding activities*” means activities which, through the employment of knowledge or labor, add value to a product, process or service that results in the creation of new wealth to the state.

[ARC 3299C, IAB 8/30/17, effective 10/4/17; ARC 6930C, IAB 3/8/23, effective 4/12/23]

**761—163.2(315) Information and forms.** Information, instructions and application forms may be obtained from the Systems Planning Bureau, Iowa Department of Transportation, 800 Lincoln Way, Ames, Iowa 50010; by telephone at (515)239-1664; or through the department's website at [www.iowadot.gov](http://www.iowadot.gov).

[ARC 3299C, IAB 8/30/17, effective 10/4/17; Editorial change: IAC Supplement 8/11/21; ARC 6930C, IAB 3/8/23, effective 4/12/23]

**761—163.3(315) Purpose of RISE program.** The purpose of the RISE program is to promote economic development in Iowa through the establishment, construction, improvement, and maintenance of roads and streets. The RISE program shall be targeted toward value-adding activities to provide maximum economic impact to the state. Value-adding activities feed new dollars into the economy. As these dollars are circulated, the state experiences economic growth. Tourism activities that result in the attraction of out-of-state dollars to the state economy may also be targeted by the program. Residential development, local government facilities, local public schools, locally oriented business services and personal services are generally not value-adding activities and will rarely meet the intent of the program.

The RISE program shall also be administered to encourage economic diversification, new business opportunities, small business development, exporting, import substitution and tourism in Iowa.

[ARC 3299C, IAB 8/30/17, effective 10/4/17]

**761—163.4(315) Administration of RISE program.**

**163.4(1)** The RISE program shall be administered by the department as a statewide program, with projects evaluated primarily on the basis of economic development criteria rather than solely on the basis of transportation criteria. In carrying out its program responsibilities, the department shall:

*a.* Involve local officials in program development and periodic program review and evaluation, including evaluation of the accomplishments and effectiveness of the RISE program. However, all project funding decisions shall be the responsibility of the commission.

*b.* Simplify application processes and administrative procedures to the maximum practicable extent.

*c.* Design the RISE program administrative procedures so that they are flexible enough to meet county and city needs.

*d.* Ensure neutrality and fairness in the treatment of all applications submitted for funding under the RISE program.

*e.* Promote intergovernmental cooperation on economic development.

*f.* Promote the use of innovative financing mechanisms for RISE projects.

**163.4(2)** The commission shall be responsible for all RISE project funding commitments. All project funding commitments are made subject to the availability of RISE funds.

**163.4(3)** The department shall annually prepare a written report indicating the amount and percentage of funds committed during the previous year on primary roads, secondary roads, city streets, state park roads and county conservation parkways.

[ARC 3299C, IAB 8/30/17, effective 10/4/17; ARC 6930C, IAB 3/8/23, effective 4/12/23]

**761—163.5(315) Source, allocation, and use of RISE funds.**

**163.5(1)** *Source.* The RISE program is funded with dedicated state motor fuel and special fuel tax revenues as set out in Iowa Code section 312.2 and chapter 315.

**163.5(2)** *Allocation and use.*

*a.* *Allocation among roadway jurisdictions.* The RISE fund shall be allocated as specified in Iowa Code section 315.4.

*b.* *Funding restricted to public roads.* The use of RISE funds is restricted to construction or improvement of primary roads, secondary roads, city streets, state park roads and county conservation parkways presently open to public use or ones which will be dedicated and open to public use in the future. RISE funds may not be used for private road projects or for any other private purpose. Project activities which may and may not be funded under the RISE program are listed in rule 163.7(315).

*c.* *Use of county or city RISE funds on primary road projects.* Counties or cities may at their option make application to the department to apply RISE funds allocated for use on secondary road or city street projects toward primary road projects. Use of county or city RISE funds on primary road projects shall be approved by the commission.

*d.* *Type of projects.* The two types of projects which may be funded under the RISE program are immediate opportunity projects and local development projects. The requirements and procedures specifically applicable to the two project types are located in the following rules of this chapter:

(1) Immediate opportunity projects: Rule 761—163.10(315).

(2) Local development projects: Rule 761—163.11(315).

*e. Relationship of project.* The demonstrated relationship of a project to economic development shall generally be the main criterion employed in determining the priority for funding. The department is required to assign the lowest priority to a project if it involves a business with wages substantially below other area businesses or with a consistent record of law violations. In terms of project type, an immediate opportunity project shall have first priority for all available RISE funds.

*f. Use of repaid funds.* RISE funds repaid to the department for any reason may be used for other projects or carried over to the next programming cycle. RISE funds repaid shall be credited to the share of the fund from which the project was originally funded.

*g. Carryover of funds.* The commission need not commit the spending of all RISE funds available during a programming cycle. Uncommitted city funds may be carried over to the next programming cycle or used for immediate opportunity projects. On June 30 of each year, all uncommitted county funds shall be credited to the secondary road fund.

*h. Reserve for future needs and contingencies.* The commission shall monitor RISE fund commitments and expected RISE fund cash flow and take actions necessary to ensure that funds remain available for anticipated present and future immediate opportunity project needs and other contingencies. Such actions may include placing a moratorium on the receipt and award of local development RISE applications, placing a limit on RISE dollars awarded to each project, or taking other actions at the discretion of the commission.

[ARC 3299C, IAB 8/30/17, effective 10/4/17; ARC 6930C, IAB 3/8/23, effective 4/12/23]

#### **761—163.6(315) Project financing and funding shares.**

**163.6(1) Financing.** Applicants may choose to propose grant financing for any RISE project. Applicants are encouraged but not required to propose below market rate interest loan, no interest loan, or partial principal payback rather than grant financing for RISE projects. The extent to which a project will return moneys to the RISE fund shall be considered in project evaluation processes. Final financial terms for all RISE projects are subject to negotiation between the department and the applicant and approval by the commission.

**163.6(2) Funding shares.** Applicants may propose the proportions and sources of RISE and non-RISE funds to be used for a project. Use of RISE funds is subject to commission approval.

[ARC 3299C, IAB 8/30/17, effective 10/4/17]

#### **761—163.7(315) Eligibility of applicants and joint applications.**

**163.7(1) Applicant eligibility.** All incorporated cities and all counties in the state of Iowa are eligible to apply for and receive funds under the RISE program. The department is also eligible to initiate projects and receive funds under this program but need not formally apply for funds. Private firms or developers or other agencies may not apply directly for funds but are encouraged to work with county or city governments in seeking funding for projects. In any case, all projects must be let by the applicant or through the department's office of contracts and in accordance with all applicable laws and rules.

**163.7(2) Joint applications.** Joint applications from two or more counties or cities are encouraged when mutual action is required to support economic development. Joint applications shall designate a lead county or city to serve as a principal contact point for the department.

[ARC 3299C, IAB 8/30/17, effective 10/4/17]

#### **761—163.8(315) Project activities eligible and ineligible for RISE funds.**

**163.8(1) Eligible activities.** Project activities or costs eligible for RISE funding, and which may be counted as part of the non-RISE participation in immediate opportunity and local development roadway projects, include only the following:

*a.* Roadway resurfacing, rehabilitation, modernization, upgrading, reconstruction or initial construction, including grading and drainage, paving, erosion control, pavement overlays, and shoulder widening and stabilization.

*b.* Bridge and culvert repair, modernization, replacement or initial construction.

*c.* Roadway intersection and interchange improvements including warranted traffic signalization when it is integral to the improvement.

*d.* Public transportation system improvements, including but not limited to bus shelters, bus turnouts, and passenger information signage, when they are integral to the roadway improvement.

*e.* Bicycle and pedestrian infrastructure improvements, including but not limited to sidewalks, at-grade pedestrian crossings, bike lanes, and separated bike lanes, when they are integral to the roadway improvement.

*f.* Right-of-way acquisition costs, including but not limited to appraisals, negotiation, compensation, and cultural resources surveys necessary to comply with applicable local, state and federal laws, rules and regulations.

*g.* Construction or improvement of motorist rest areas, welcome centers, and information centers.

*h.* Design engineering costs leading to construction plan development and construction inspection costs associated with RISE-financed projects.

*i.* County and city bond principal and interest payments associated only with RISE projects. No financing expenses incurred prior to funding commitment shall be eligible, and no administrative or legal expenses may be reimbursed. The bond term may not exceed the expected useful life of the roadway.

*j.* Storm drainage and storm sewer costs to the extent needed for draining the roadway.

*k.* Reconstruction or adjustment of utilities, including but not limited to water, sanitary sewer, electric, telephone, and natural gas, when utilities are located on private property and require replacement or relocation due to project construction; or said utilities are located in the public right-of-way and the utility is not required to relocate at its own expense.

*l.* Costs associated with the acquisition of local, state and federal permits required for roadway construction.

*m.* Costs of modifications to railroad facilities required to construct the RISE roadway, including but not limited to construction, hiring flaggers, and engineering performed by the railroad or the railroad's contractor, that are consistent with an executed agreement between the railroad and the roadway jurisdiction.

**163.8(2) *Ineligible activities.*** Activities or costs ineligible for RISE funding, and which may not be counted as part of the non-RISE participation in immediate opportunity or local development roadway projects, include but are not limited to the following:

*a.* Any and all costs incurred prior to a funding commitment by the commission notwithstanding rule 761—163.9(315).

*b.* Routine roadway, bridge and culvert maintenance, including but not limited to pothole filling, crack sealing, seal coating, patching, shoulder maintenance, gravel or earth roadway maintenance, and bridge painting.

*c.* Winter roadway and bridge maintenance, including but not limited to snow plowing, sanding, and salting.

*d.* Overhead and operating costs associated with eligible project activities, including auditing.

*e.* Expenses associated with the preparation and submission of applications for RISE funding.

*f.* Predesign engineering, feasibility or alignment studies, and other planning expenses.

*g.* Traffic signalization, except as an integral part of a roadway project.

*h.* Pavement marking and traffic signs, except as an integral part of a roadway project.

*i.* Utility construction, reconstruction or adjustment except for those activities or costs described in subrule 163.8(1).

*j.* Safety appurtenances, except as an integral part of a roadway project.

*k.* Lighting, except as an integral part of a roadway project.

*l.* Lighting energy and maintenance costs.

*m.* Sidewalks, bicycle paths, and railroad-highway crossings, except when replacing those facilities in service and affected by the project, or as an integral part of a roadway project.

*n.* Parking expenditures, including those for structures, lots, meters, paving, and marking whether for on-street or off-street parking.

*o.* Nonroadway transportation expenditures, including those for railway, aviation, public transportation, and inland waterway facilities and equipment.

*p.* Purchase of furnishings, construction equipment, and personal property.

*q.* General government expenses and expenses associated with the provision of any public service which are not eligible for RISE program assistance.

*r.* Donated right-of-way.

[ARC 3299C, IAB 8/30/17, effective 10/4/17; ARC 6930C, IAB 3/8/23, effective 4/12/23]

**761—163.9(315) Advance eligibility of land acquisition and preliminary design costs incurred prior to funding commitment by commission.**

**163.9(1) *Need for advance eligibility.*** If there is extreme urgency involving land acquisition or preliminary design and a necessity to protect or preserve a project corridor or to proceed with the preparation of project construction plans prior to a RISE funding commitment, a potential applicant may submit a written request to the department for a determination of advance eligibility to incur costs for land acquisition or preliminary design immediately. A determination of advance eligibility by the department will allow specified costs incurred prior to a funding commitment by the commission to be eligible for reimbursement with RISE funding without jeopardizing the project's eligibility for funding approval, but does not imply or guarantee that the commission will commit RISE funding to a subsequent application.

**163.9(2) *Request, justification and review.*** The request must be received by the department prior to the expenditure and must include justification regarding the extreme urgency and necessity to incur costs prior to a RISE

funding commitment. A request for land acquisition must also include a description of the land to be acquired, a summary of the estimated costs, and a map showing the parcels to be acquired. Preliminary design requests must include a description of the project scope, location map, and proposed cross section. If the request will include consultant design costs, a draft agreement between the jurisdiction and the consultant must be submitted which includes the scope of services to be rendered. Costs for RISE application preparation and submission or project feasibility, route alignment studies or other planning expenses as cited in paragraphs 163.8(2)“e” and “f” remain ineligible for RISE funding and shall not be included in a request for determination of advance eligibility. The department will review the submittal. If the requirements of this rule are met, the department will provide written confirmation of the determination of advance eligibility.

**163.9(3) Requirements.** Any cost incurred before the request is received by the department will be ineligible for reimbursement. Costs receiving a determination of advance eligibility must be noted in the subsequent RISE funding application submitted to the department. Land acquired or design work completed following a determination of advance eligibility will not be eligible for reimbursement with RISE funds if the property acquired or design work completed is not necessary to construct the proposed RISE project included in the subsequent application. Design costs receiving a determination of advance eligibility may not exceed 10 percent of the total construction costs for the project. An application for funding which includes the expenditure must be received by the department within two years following the determination of advance eligibility, or the costs may become ineligible for RISE funding.

[ARC 3299C, IAB 8/30/17, effective 10/4/17]

#### **761—163.10(315) Immediate opportunity projects.**

**163.10(1) General provisions.** The following provisions are applicable to immediate opportunity projects:

- a. Immediate opportunity projects may be located on primary roads, secondary roads, city streets, state park roads or county conservation parkways.
- b. There is no restriction on the number of applications per county or city that will be considered for RISE funding.
- c. Counties and cities may apply for single-year or multiyear funding. Multiyear funding shall be limited to funding commitments from no more than three program years' allocations.
- d. Applicants may use staff from other counties or cities, areawide planning organizations, areawide economic development organizations, or other jurisdictions to prepare application materials or administer projects.
- e. There must be an adequate transportation justification for the roadway project. The proposed improvement need not be designed prior to project application, but the concept must generally be reasonable from a transportation planning and engineering standpoint and detailed enough to enable project cost estimates to be developed.

**163.10(2) Contents of applications.** Each application for an immediate opportunity project must contain the following:

- a. General information, including the applicant's name, contact person, mailing address, telephone number, local economic development area and history of efforts in the area, and other information of a general nature about the project proposal and the associated economic development activity.
- b. Cost information, including the estimated total capital investment involved with the associated economic development activity, the estimated total cost of the roadway project, the amount of RISE funds requested for the roadway project, and the amount of non-RISE funds to be used to match or supplement RISE funding. Itemized breakdowns (showing the item, cost, and funding source) must be included for the total capital investment, the total roadway project cost, the RISE funds requested, and the non-RISE funds to be used to match or supplement RISE funding.
- c. Data showing the impact of the associated economic development activity, including the number of direct jobs created or retained. Jobs created as a result of jobs being displaced elsewhere in the state shall not be considered direct jobs created for the purpose of evaluating the application.
  - (1) To expedite the review, the applicant shall provide the following data for each business included in the project justification: a list of in-state competitors; a list of in-state suppliers; the percentage of out-of-state sales; the effect on import substitution; long-range growth potential; and a list of all current and anticipated employment positions, both full- and part-time, the hourly wage for each, and the turnover rate.
  - (2) The applicant shall certify that each business will give hiring preference to residents of the state or local area, except for out-of-state employees offered a transfer to Iowa.
- d. A preliminary project concept statement for the roadway project, including maps showing site characteristics, such as zoning, platting, subdivision boundaries, and corporate limits; a sketch plan; and a justification for the transportation improvement. In most cases, a sketch plan should include a simple plan and profile defining the horizontal and vertical geometrics and a typical roadway cross section defining pavement, shoulders, foreslope, and

backslope or border treatment. The transportation justification should address topics such as the current condition of existing roadways or bridges, the relationship of the project to connecting roads, and ingress to and egress from the site, as well as the current flow of traffic on the development site, anticipated total traffic and large truck traffic, proposed major design features of the proposed improvement, the intended roadway function, how the proposed improvement is consistent with other local plans, and the reason the proposed alternative was selected over other alternatives. In consultation with the department, a traffic impact analysis may be required to supplement the transportation justification.

*e.* A time schedule for the total development, including the roadway project and the associated economic development activity.

*f.* A formal resolution passed by the governing body of the jurisdiction responsible or to be responsible for the road or street to be constructed or improved. The resolution shall state that the project will be adequately maintained and dedicated to public use for a minimum of 20 years after completion of the project and that land provided access by the proposed improvement will be developed according to rule 761—163.3(315). The resolution must also certify that the project meets the threshold criteria cited in paragraph 163.10(6) “a” and that any business assisted by the project which acquires or merges with an Iowa corporation within three years following the RISE application shall make a good-faith effort to hire the workers of the merged or acquired company.

*g.* Documentation showing that the threshold criteria of subrule 163.10(6) have been met.

**163.10(3) *Submission of applications.*** Applications shall be submitted on a form provided by the department. Applications may be submitted at any time.

Once an application has been submitted, no further information concerning that application shall be accepted by the department from the applicant unless specifically requested by the department. Applications may be withdrawn by the applicant and resubmitted at any time. Resubmitted applications shall be dated accordingly.

**163.10(4) *Incomplete applications.*** An applicant must satisfy the application requirements outlined in this chapter and must fully complete the official application form before the application will be considered by the commission.

**163.10(5) *Verification of application materials.*** Complete applications shall be reviewed to verify the figures or statements in the applications. This may include site visits. If inaccuracies, omissions, or errors are found, the commission may rescind the commitment of funds or reevaluate the application based on the correct information. If an applicant loses funding through this process, the commission shall have complete discretion concerning the disposition of those funds, including awarding them to other applicants or carrying them over to the next programming cycle.

**163.10(6) *Threshold criteria.*** Funding commitment decisions for immediate opportunity projects shall be made on an individual basis. There is no competitive ranking of project applications. In order to gain a funding commitment, an application must meet all of the following threshold criteria:

*a.* The project must be related to an immediate, nonspeculative opportunity for permanent job creation or retention. The applicant county or city (or its agent) should be in the process of negotiating a location or retention decision with a developer or firm.

*b.* The applicant must demonstrate that an immediate funding commitment is essential to influence the job location or retention decision.

*c.* The applicant must demonstrate that necessary arrangements have been made for nonroadway factors (e.g., labor force training, zoning, sewer, water, police and fire protection, financing, and permits) essential for the proposed job creation or job retention activity.

*d.* There must be at least 20 percent non-RISE financial participation in the roadway project, except the commission may approve a participation amount that is less than 20 percent if it determines that the applicant city or county is economically distressed.

*e.* There must be a strong likelihood that the total development, including the roadway project, can be completed in a timely manner. It is up to the applicant to identify a time schedule and maintain it. This time schedule may be adjusted for such reasons including but not limited to the project involves unusually complex engineering studies, extensive real estate negotiations, extensive analysis for environmental clearances, or unusually complex planning for associated development. The commission may withdraw funding if time schedules have been misrepresented or have not been maintained.

**163.10(7) *Review and funding of applications.***

*a.* The staff of the department shall review complete immediate opportunity project applications and may consult with other organizations with economic development responsibilities. As part of the review, the staff shall evaluate the effect of the proposed project on the state economy using the following factors: consistency with the state economic development plan; diversification of the state economy; the impact on in-state suppliers, competitors, and import substitution; percentage of out-of-state sales; the quality of employment positions; and the record of law

violations. This review shall be performed within a reasonable period of time after receipt of the application. Following this review, complete applications meeting the threshold criteria of subrule 163.10(6) shall be forwarded to the commission for action at its next meeting.

b. The commission may fund all or any part of an application and may make a conditional funding commitment. In making its decision, the commission will consider the amount of total capital investment per RISE dollar requested, and the amount of RISE dollars requested per job created or retained.

c. The commission may deny funding for projects which will not result in net job creation or job retention from a statewide point of view, for instance, projects which simply involve the relocation of jobs or other economic activity within Iowa.

d. Immediate opportunity project applications may, at the discretion of the commission, be considered as applications for local development projects. These applications shall be included in the current round of local development project programming, regardless of the deadlines stated in subrule 163.11(3). However, immediate opportunity project applications submitted solely to circumvent the deadlines for local development project applications shall not be considered in this manner.

[ARC 3299C, IAB 8/30/17, effective 10/4/17; ARC 6930C, IAB 3/8/23, effective 4/12/23]

### **761—163.11(315) Local development projects.**

**163.11(1) General provisions.** The following provisions are applicable to local development projects:

a. Local development projects may be located on primary roads, secondary roads, city streets, state park roads or county conservation parkways.

b. There is no restriction on the number of applications per county or city that will be considered for RISE funding.

c. Counties and cities may apply for single-year or multiyear funding. Multiyear funding shall be limited to funding commitments from no more than three program years' allocations.

d. Applicants may use staff from other counties or cities, areawide planning organizations, areawide economic development organizations, or other jurisdictions to prepare application materials or administer projects.

e. There must be an adequate transportation justification for the roadway project. The proposed improvement need not be designed prior to project application, but the concept must generally be reasonable from a transportation planning and engineering standpoint and detailed enough to enable project cost estimates to be developed.

**163.11(2) Contents of applications.** Each application for a local development project must contain the following:

a. General information, including the applicant's name, contact person, mailing address, telephone number, local economic development program and history of efforts in the area, and other information of a general nature about the project proposal and the associated economic development activity.

b. Cost information, including the estimated total capital investment involved with the associated economic development activity, the estimated total cost of the roadway project, the amount of RISE funds requested for the roadway project, and the amount of non-RISE funds to be used to match or supplement RISE funding. Itemized breakdowns (showing the item, cost and funding source) must be included for the total capital investment, the total roadway project cost, the RISE funds requested, and the non-RISE funds to be used to match or supplement RISE funding.

c. Data showing the impact of the associated economic development activity, including the number of direct jobs created or retained. Jobs created as a result of jobs being displaced elsewhere in the state shall not be considered direct jobs created for the purpose of evaluating the application.

(1) To expedite the review, the applicant shall provide the following data for each business included in the project justification: a list of in-state competitors; a list of in-state suppliers; the percentage of out-of-state sales; the effect on import substitution; long-range growth potential; and a list of all current and anticipated employment positions, both full- and part-time, the hourly wage for each, and the turnover rate.

(2) The applicant shall certify that each business will give hiring preference to residents of the state or local area, except for out-of-state employees offered a transfer to Iowa.

d. A preliminary project concept statement for the roadway project, including maps showing site characteristics such as zoning, platting, subdivision boundaries, and corporate limits; a sketch plan; and a justification for the transportation improvement. In most cases, a sketch plan should include a simple plan and profile defining the horizontal and vertical geometrics and a typical roadway cross section defining pavement, shoulders, foreslope, and backslope or border treatment. The transportation justification should address topics such as the current condition of existing roadways or bridges, the relationship of the project to connecting roads, and ingress to and egress from the site, as well as the current flow of traffic on the development site, anticipated total traffic and large truck traffic, proposed major design features of the proposed improvement, the intended roadway function, how the proposed

improvement is consistent with other local plans, and the reason the proposed alternative was selected over other alternatives. In consultation with the department, a traffic impact analysis may be required to supplement the transportation justification.

*e.* A time schedule for the total development, including the roadway project and the associated economic development activity.

*f.* A formal resolution passed by the governing body of the jurisdiction responsible or to be responsible for the road or street to be constructed or improved. The resolution shall state that the project will be adequately maintained and dedicated to public use for a minimum of 20 years after completion of the project and that land provided access by the proposed improvement will be developed according to rule 761—163.3(315). The resolution must also certify that any business assisted by the project which acquires or merges with an Iowa corporation within three years following the RISE application shall make a good-faith effort to hire the workers of the merged or acquired company.

*g.* A summary showing that necessary arrangements have been made for nonroadway factors (e.g., zoning, sewer, water, police and fire protection, financing, and permits) essential for the proposed economic development activity.

**163.11(3)** *Submission of applications.* Applications shall be submitted on a form provided by the department.

*a.* Applications may be submitted at any time. However, in order to be considered in the current round of programming, complete applications must be received by the department or postmarked no later than February 1 or September 1.

*b.* Once an application has been submitted, no further information concerning that application shall be accepted by the department from the applicant unless specifically requested by the department. Applications may be withdrawn by the applicant and resubmitted at any time. Resubmitted applications shall be dated accordingly.

**163.11(4)** *Incomplete applications.* An applicant must satisfy the application requirements outlined in this chapter and must fully complete the official application form before the application will be considered by the commission. An applicant shall be notified if an application is incomplete.

**163.11(5)** *Verification of application materials.* Complete applications shall be reviewed to verify the figures or statements in the applications. This may include site visits. If inaccuracies, omissions, or errors are found, the commission may rescind the commitment of funds or reevaluate the application based on the correct information. If an applicant loses funding through this process, the commission shall have complete discretion concerning the disposition of those funds, including awarding them to other applicants or carrying them over to the next programming cycle.

**163.11(6)** *Rating factors.* The following factors and potential rating points shall be used in assessing applications for local development projects. Assessment of these factors shall be the responsibility of the department.

*a.* *Development potential.* This factor measures the degree of certainty involved in the economic development activity to be supported by the proposed RISE project and the potential for future job growth. Maximum points: 35.

*b.* *Economic impact.* This factor measures the economic impact of the development activity to be supported by the proposed RISE project, including the number of direct jobs assisted, investment leveraging, the percentage of out-of-state sales and in-state suppliers, the impact on competition and diversification, and the quality of job factors. Maximum points: 20.

*c.* *Local commitment and initiative.* This factor measures the level of effort being put forth by the applicant to attract economic development and the adequacy of the supporting infrastructure. Maximum points: 35 (includes 5 points for the remediation or redevelopment of a brownfield site).

*d.* *Transportation need.* This factor measures the condition and quality of existing road or street service. Maximum points: 4.

*e.* *Area economic need.* This factor measures the economic condition of the area. Maximum points: 6.

**163.11(7)** *Review and funding of applications.*

*a.* The staff of the department shall review and rate complete local development project applications and may consult with other organizations with economic development responsibilities. As part of the review, the staff shall evaluate the effect of the proposed project on the state economy using the following factors: consistency with the state economic development plan; diversification of the state economy; the impact on in-state suppliers, competitors, and import substitution; percentage of out-of-state sales; the quality of employment positions; and the record of law violations. Complete applications shall be forwarded to the commission for a funding commitment action within a reasonable period of time after the application deadline. An application considered but not funded in one programming cycle must be resubmitted by the applicant if it is to be considered in a subsequent cycle.

*b.* The commission may fund all or any part of an application and may make a funding commitment conditional upon adherence to a specific time schedule, realization of a development prospect, or fulfillment of other agreements.

[ARC 3299C, IAB 8/30/17, effective 10/4/17; ARC 6930C, IAB 3/8/23, effective 4/12/23]

**761—163.12(315) Project administration.**

**163.12(1) Agreement.** After a funding commitment has been made for a project, the department shall enter into a project agreement with the applicant. The agreement shall delineate responsibilities for project planning, design, right-of-way, contracting, construction and materials inspection, and documentation. The agreement shall identify any additional requirements for the project relating to specific jobs to be created or retained and land identified as being required to be developed consistent with rule 761—163.3(315). Procedures for documenting compliance with these requirements will also be identified in the agreement. The agreement shall require the applicant to comply with all local, state, and federal laws, and rules and regulations that may apply to the project.

**163.12(2) Project payments.** Payments from the RISE fund to counties or cities shall be made on a cost reimbursement basis, and financial participation shall be limited to the maximum percentage allowed by the funding commitment. The non-RISE financial participation shall include only those items listed as eligible for RISE funding and may be in the form of cash, the value of design engineering and construction inspection services, or the cost of eligible advance right-of-way acquisitions or preliminary design pursuant to rule 761—163.9(315). Grants from other state agencies or programs may also contribute to the non-RISE financial participation if their laws and rules allow. The applicant shall provide documentation to the department supporting the value of any noncash contribution to the project. The department has the sole authority to determine the value of noncash contributions. Contributions made by a third party may be allowed.

**163.12(3) Project expenditures incurred prior to agreement.** Project expenditures incurred after the commission has made a funding commitment, but before execution of the agreement, are eligible for reimbursement if a project agreement is subsequently executed. However, under no circumstances shall any reimbursement be paid until the agreement has been executed.

**163.12(4) Remedies for noncompliance with project agreement.** The commission may revoke funding commitments, require repayment of RISE funds loaned or granted, or take both actions when the county or city has not fulfilled the terms of the project agreement.

**163.12(5) Cost overruns.** RISE funds committed for projects are for a maximum dollar amount. Cost overruns shall be the responsibility of the administering jurisdiction.

**163.12(6) Audit.** The department may audit all project costs incurred for compliance with the agreement, including costs that are part of the matching contribution. All force account work performed by a county or city on the project shall be audited.

[ARC 3299C, IAB 8/30/17, effective 10/4/17; ARC 6930C, IAB 3/8/23, effective 4/12/23]

These rules are intended to implement Iowa Code section 312.2 and chapter 315.

[Filed emergency 10/10/85—published 11/6/85, effective 10/11/85]

[Filed 1/22/86, Notice 11/6/85—published 2/12/86, effective 3/19/86]

[Filed 10/10/86, Notice 8/13/86—published 11/5/86, effective 12/10/86]

[Filed 5/11/87, Notice 3/11/87—published 6/3/87, effective 7/8/87]

[Filed 10/20/88, Notice 9/7/88—published 11/16/88, effective 12/21/88]

[Filed 1/9/91, Notice 11/28/90—published 2/6/91, effective 3/13/91]

[Filed 1/15/92, Notice 12/11/91—published 2/5/92, effective 3/11/92]

[Filed emergency 7/18/01 after Notice 5/16/01—published 8/8/01, effective 7/20/01]

[Filed 12/17/02, Notice 10/16/02—published 1/8/03, effective 2/12/03]

[Filed ARC 3299C (Notice ARC 3131C, IAB 6/21/17), IAB 8/30/17, effective 10/4/17]

[Editorial change: IAC Supplement 8/11/21]

[Filed ARC 6930C (Notice ARC 6750C, IAB 12/14/22), IAB 3/8/23, effective 4/12/23]



CHAPTER 164  
TRAFFIC SAFETY IMPROVEMENT PROGRAM

**761—164.1(312) Definitions.**

“*Commission*” means the Iowa transportation commission.

“*Department*” means the Iowa department of transportation.

“*Jurisdiction*” means the department, a county, a city or any other public agency having responsibility for and control over a road or street.

“*Other public agency*” means any board, commission or agency having jurisdiction and control over roads and streets in any state park, state institution and other state land. State park, state institution and other state land means as defined in Iowa Code section 306.3(10).

“*Traffic safety improvement program*” means the funding program created for traffic safety improvement projects pursuant to Iowa Code section 312.2(11).

[ARC 4532C, IAB 7/3/19, effective 8/7/19]

**761—164.2(312) Information and forms.** Information, instructions and application forms may be obtained from the Traffic and Safety Bureau, Iowa Department of Transportation, 800 Lincoln Way, Ames, Iowa 50010; telephone (515)239-1557; or on the department’s website at [www.iowadot.gov](http://www.iowadot.gov).

[ARC 4532C, IAB 7/3/19, effective 8/7/19]

**761—164.3(312) Program administration.**

**164.3(1) Purpose.** The traffic safety improvement program provides funding for traffic safety improvements or studies on public roads under county, city or state jurisdiction.

**164.3(2) Local participation.** The department shall administer the traffic safety improvement program as a statewide program and will coordinate local participation in the review and evaluation of applications for funding.

**164.3(3) Funding.**

*a.* The traffic and safety bureau shall review all applications and the availability of funds in order to make funding recommendations to the commission. The commission may choose to fund all or part of a project or limit funding to specific work items. Funding may also be made dependent upon adherence to a time schedule or fulfillment of specified conditions.

*b.* The commission need not commit all funds available during a fiscal year. Funds not committed by the commission shall be retained for subsequent programming cycles. Awarded funds not used within a specified period or remaining after project closure shall be retained for subsequent programming cycles.

*c.* The maximum traffic safety improvement program funding for a site-specific improvement shall not exceed \$500,000. Total funding allotted for the traffic control device category shall not exceed \$500,000 annually. Total funding allotted for the studies and outreach category shall not exceed \$500,000 annually. All project costs exceeding the commitment of traffic safety improvement program funds shall be the responsibility of the applicant.

[ARC 4532C, IAB 7/3/19, effective 8/7/19]

**761—164.4(312) Applicant eligibility.** Any jurisdiction in the state of Iowa is eligible to apply for traffic safety improvement program funding. Applicants shall designate one jurisdiction as the principal contact for a project involving multiple jurisdictions.

[ARC 4532C, IAB 7/3/19, effective 8/7/19]

**761—164.5(312) Project eligibility.** Projects located on a public roadway within the state of Iowa are eligible for funding. Projects located on a private road or for a private purpose are not eligible.

[ARC 4532C, IAB 7/3/19, effective 8/7/19]

**761—164.6(312) Eligible project costs.**

**164.6(1) Site-specific improvements category.** Activities considered eligible for funding are those required by, or integral to, the safety aspects of the project. Eligible activities include, but are not limited to, the following:

- a.* Road modernization, upgrading or reconstruction.
- b.* Intersection improvements.
- c.* Right-of-way purchases.
- d.* Drainage and erosion control measures.
- e.* Traffic control devices.
- f.* Traffic barriers and other roadside safety devices.

g. Removal of trees and other fixed objects.

**164.6(2)** *Traffic control devices category.* The cost of materials purchased for initial installation of traffic control devices or replacement of obsolete traffic control devices is considered eligible for funding. Devices shall comply with the applicable warrants in the “Manual on Uniform Traffic Control Devices” (MUTCD) as adopted in rule 761—130.1(321).

**164.6(3)** *Studies and outreach category.* Activities considered eligible for funding include, but are not limited to, the following:

- a. Research addressing statewide traffic safety concerns.
- b. Studies addressing traffic safety concerns at specific locations.
- c. Initiatives emphasizing or improving traffic safety techniques or policies.

[ARC 4532C, IAB 7/3/19, effective 8/7/19]

**761—164.7(312) Ineligible project costs.**

**164.7(1)** Any and all costs incurred prior to commission approval of funding for a project are ineligible.

**164.7(2)** Activities and costs not eligible for traffic safety improvement program funding within the site-specific improvements category include, but are not limited to:

- a. Routine maintenance of a road, street, bridge, culvert or traffic control device.
- b. Contract administration costs.
- c. Design and construction engineering and inspection.
- d. Utility construction, reconstruction or adjustment, except as an integral part of a project.
- e. Sidewalks, shared-use paths, or railroad-highway crossings, except as an integral part of a project.
- f. Maintenance or energy costs for traffic control devices or lighting.
- g. Expenditures for items not related to the roadway.

**164.7(3)** Activities and costs not eligible for traffic safety improvement program funding within the traffic control devices category include, but are not limited to:

- a. Maintenance or energy costs.
- b. Installation costs.

[ARC 4532C, IAB 7/3/19, effective 8/7/19]

**761—164.8(312) Applications.** Applications for funding shall address needs in one of three categories: site-specific improvements, traffic control devices, or studies and outreach. Application procedures for each funding category will be distinct.

**164.8(1)** Applications in the site-specific improvements category shall be submitted electronically on forms provided on the department’s website. Required information shall include:

- a. The applicant’s name, mailing address, telephone number, and a designated contact person.
- b. A preliminary project concept statement, including a location map and a sketch plan. The concept must be reasonable from a traffic engineering standpoint and detailed enough to generate project cost estimates.
- c. Justification for the proposed construction project. Justification may be based on a location’s crash history, a location’s crash risk, or recommendations from a traffic study.
- d. Data showing the anticipated effect of the project on traffic safety. Data shall include crash history based on the department’s current crash analysis software and the anticipated crash reduction as a result of the project.
- e. An itemized cost estimate for the project including a list of the sources and amounts of supplementary funds for the project. Safety-related work items and quantities shall be listed separately.
- f. A time schedule for the project.
- g. The jurisdiction’s official endorsement, where applicable, of the project and written assurance that the improved site will be adequately maintained for a specified period of time.

**164.8(2)** Applications in the traffic control devices category shall be submitted electronically on forms provided on the department’s website. Required information shall include:

- a. The applicant’s name, mailing address, telephone number, and a designated contact person.
- b. A list of the number and types of devices requested, and whether each is for initial placement or a replacement.
- c. Justification for the requested devices, including compliance with the applicable warrants in the “Manual on Uniform Traffic Control Devices” (MUTCD) as adopted in rule 761—130.1(321).
- d. A cost estimate.
- e. A time schedule for installation.

*f.* The jurisdiction's official endorsement of the traffic control device project and written assurance that the traffic control device will be adequately maintained for a specified period of time.

**164.8(3)** Applications in the studies and outreach category shall be submitted electronically on forms provided on the department's website. Required information shall include:

- a.* The applicant's name, mailing address, telephone number and a designated contact person.
- b.* A description of the proposed subject matter and the goals or expected results of the effort.
- c.* A cost estimate.
- d.* A time schedule.

[ARC 4532C, IAB 7/3/19, effective 8/7/19]

#### **761—164.9(312) Processing the application.**

##### **164.9(1) Submission.**

*a.* The jurisdiction shall submit the complete application electronically to the traffic and safety bureau. An application may be submitted at any time.

*b.* Complete applications received before August 16 of each year shall be evaluated for funding in the following state fiscal year.

*c.* An unfunded application may be resubmitted for consideration during a subsequent funding cycle.

*d.* An application may be withdrawn at any time.

**164.9(2) Approval of projects.** Department staff shall prepare, with input from local officials, a proposed program of projects for each funding category and submit the programs to the commission for approval. The criterion for determining funding priorities in each category is the demonstrated relationship of the project to traffic safety.

[ARC 7618B, IAB 3/11/09, effective 4/15/09; ARC 0033C, IAB 3/7/12, effective 4/11/12; ARC 4532C, IAB 7/3/19, effective 8/7/19]

#### **761—164.10(312) Project agreement.**

**164.10(1)** After the commission has approved funding, a project agreement shall be negotiated and executed between the department and the jurisdiction. The agreement shall specify the conditions for project funding, which may include such items as the responsibility for planning, design, right-of-way, contracting, construction, materials inspection, documentation and the criteria for each. The agreement shall also specify the funding level for the eligible work items.

**164.10(2)** The department shall reimburse the jurisdiction for actual eligible project costs not to exceed the amounts authorized by the project agreement.

[ARC 4532C, IAB 7/3/19, effective 8/7/19]

These rules are intended to implement Iowa Code section 312.2(11).

[Filed emergency 9/22/88 after Notice 8/10/88—published 10/19/88, effective 9/30/88]

[Filed 1/15/92, Notice 12/11/91—published 2/5/92, effective 3/11/92]

[Filed emergency 11/17/98—published 12/16/98, effective 11/19/98]

[Filed 10/10/02, Notice 8/7/02—published 10/30/02, effective 12/4/02]

[Filed ARC 7618B (Notice ARC 7482B, IAB 1/14/09), IAB 3/11/09, effective 4/15/09]

[Filed ARC 0033C (Notice ARC 9968B, IAB 1/11/12), IAB 3/7/12, effective 4/11/12]

[Filed ARC 4532C (Notice ARC 4385C, IAB 4/10/19), IAB 7/3/19, effective 8/7/19]



CHAPTER 165  
RECREATIONAL TRAILS PROGRAM

**761—165.1(465B) Definitions.**

“*Authority*” means a state or local government agency, municipal corporation, county or nonprofit organization having authority and responsibility for a trail.

“*Commission*” means the state transportation commission.

“*Department*” means the Iowa department of transportation.

“*Recreational trail*” means a thoroughfare or track across land or snow, used for recreational purposes such as pedestrian activities including wheelchair use; skating or skateboarding; equestrian activities, including carriage driving; nonmotorized snow trail activities, including skiing; bicycling or use of other human-powered vehicles; providing access to aquatic or water activities; and motorized vehicular activities, including all-terrain vehicle riding, motorcycling, snowmobiling, use of off-road light trucks, or use of other off-road motorized vehicles.

“*Recreational trails funds*” means funds appropriated for the acquisition, construction, and improvement of recreational trails.

[ARC 3300C, IAB 8/30/17, effective 10/4/17]

**761—165.2(465B) Information and forms.** Information, instructions and application forms may be obtained from the Office of Systems Planning, Iowa Department of Transportation, 800 Lincoln Way, Ames, Iowa 50010; telephone (515)239-1664; or through the department’s website at [www.iowadot.gov](http://www.iowadot.gov).

[ARC 3300C, IAB 8/30/17, effective 10/4/17; Editorial change: IAC Supplement 8/11/21]

**761—165.3 and 165.4** Reserved.

**761—165.5(465B) Program administration.**

**165.5(1) Purpose.** The recreational trails program provides funds to establish recreational trails in Iowa for the use, enjoyment and participation of the public. The department shall administer the recreational trails fund as a statewide program.

**165.5(2) Funding.**

a. The commission is solely responsible for all funding commitments and shall determine the projects to be funded, subject to the availability of recreational trails funds. The commission may approve, modify, or deny an application. The commission may fund all or part of a project and may make funding conditional upon adherence to a time schedule or to fulfillment of an agreement.

b. The commission need not commit all funds available during a programming cycle. The commission may reserve unexpended or repaid funds for the next programming cycle or for anticipated present and future project needs and other contingencies.

c. Project costs that exceed the commission’s funding commitment shall not be eligible for reimbursement from the recreational trails fund. Reimbursement for project costs shall be limited to the percentage match approved by the commission and actual eligible project costs incurred.

[ARC 3300C, IAB 8/30/17, effective 10/4/17]

**761—165.6 to 165.8** Reserved.

**761—165.9(465B) Applicant eligibility.**

**165.9(1)** A state or local government agency, a municipal corporation, a county or a nonprofit organization is eligible to apply for and receive funds from the recreational trails program.

**165.9(2)** A private business or developer is not eligible to apply directly for funds from the recreational trails program.

[ARC 3300C, IAB 8/30/17, effective 10/4/17]

**761—165.10 and 165.11** Reserved.

**761—165.12(465B) Project eligibility.**

**165.12(1) Public use.** The recreational trails program is restricted to the acquisition, construction or improvement of recreational trails open for public use or trails which will be dedicated to public use upon completion. A private trail project or a project for a private purpose is not eligible for funding under this program.

**165.12(2) Criteria.** A proposed recreational trails project shall meet all of the following requirements:

- a. The project must be part of a local, areawide, regional or statewide plan.
- b. The trail route shall be designed to allow enjoyment of scenic views or points of historical interest and to maximize safety. The route may use existing roads, streets or parkways, if the normal flow of motor vehicle traffic will not be hindered, abandoned railroad corridors, utility corridors, or new right-of-way as necessary.
- c. The project shall include a contribution of at least 25 percent matching funds.
- d. Matching funds may include grants from other state agencies or programs if their laws and rules allow and the donation of in-kind labor, materials, equipment, and services from a third party. The department has the sole authority to determine the value of noncash contributions. The value of donated land may be an eligible matching contribution if:

- (1) The land is donated after the commission's funding commitment, and
- (2) The value is based on a real estate appraisal acceptable to the department. The appraisal is subject to review and approval by the department after a funding commitment has been made.

[ARC 3300C, IAB 8/30/17, effective 10/4/17]

**761—165.13 and 165.14** Reserved.

**761—165.15(465B) Eligible project costs.**

**165.15(1) Land.** Land acquisition costs including, but not limited to, appraisals, negotiation, compensation and cultural resources surveys necessary to comply with applicable local, state and federal laws, rules and regulations are eligible project costs. Land may be acquired by lease, easement or fee simple and as allowed by Iowa Code section 6A.21. The performance of land negotiation and acquisition activities shall not be the responsibility of the department although the department may provide advisory services.

**165.15(2) Other eligible costs.** Other project costs that are eligible for funding are limited to the following:

- a. Trail surfacing, resurfacing, rehabilitation, modernization, upgrading and reconstruction, including pavement repairs and overlays and shoulder widening and stabilization; or initial trail construction including grading, drainage, paving and erosion control.
- b. Bridge and culvert repair, modernization, replacement or initial construction.
- c. Roadway intersection and interchange improvements, including warranted traffic signalization that is an integral part of the project.
- d. Construction or improvement of rest areas, information centers, waysides, permanent interpretive displays, lighting and rest rooms, including the costs of utility connections that are an integral part of the project.
- e. Design engineering costs leading to construction plan development and construction inspection costs directly associated with the project.
- f. Storm drainage and storm sewer costs to the extent needed for draining the trail.
- g. Reconstruction or adjustment of utilities including but not limited to water, sanitary sewer, electric, telephone, and natural gas when utilities are located on private property and require replacement or relocation due to project construction; or said utilities are located in the public right-of-way and the utility is not required to relocate at its own expense.
- h. Trail signs, fencing, landscaping, parking areas, and walkways.

[ARC 3300C, IAB 8/30/17, effective 10/4/17]

**761—165.16** Reserved.

**761—165.17(465B) Ineligible project costs.**

**165.17(1) Before commission approval.** Any and all costs incurred prior to a funding commitment by the commission are ineligible for funding notwithstanding rule 761—165.19(465B).

**165.17(2) Other ineligible costs.** Other project costs that are ineligible for funding include, but are not limited to, the following:

- a. Routine maintenance of a trail, bridge, culvert, fence or sign; winter maintenance of a trail or bridge, including but not limited to snow plowing, sanding, and salting.
- b. Overhead and operating costs associated with a project, such as auditing, legal and administrative costs.
- c. Expenses associated with the preparation and submission of a project application.
- d. Predesign engineering, feasibility, or alignment studies and other planning expenses.
- e. Utility construction, reconstruction or adjustment except for those activities or costs described in subrule 165.15(2).
- f. Pavement markings, traffic signs, safety appurtenances or lighting except as an integral part of a trail project.

- g. Purchases of office furnishings or equipment, construction or maintenance equipment, or personal property.
- h. General government expenses and expenses associated with the provision of any public service that are not otherwise eligible for project funding.

[ARC 3300C, IAB 8/30/17, effective 10/4/17]

**761—165.18** Reserved.

**761—165.19(465B) Advance eligibility of land acquisition and preliminary design costs incurred prior to funding commitment by commission.**

**165.19(1)** *Need for advance eligibility.* If there is extreme urgency involving land acquisition or preliminary design and a necessity to protect or preserve a project corridor or to proceed with the preparation of project construction plans prior to a recreational trails program funding commitment, a potential applicant may submit a written request to the department for a determination of advance eligibility to incur costs for land acquisition or preliminary design immediately. A determination of advance eligibility by the department will allow specified costs incurred prior to a funding commitment by the commission to be eligible for reimbursement with recreational trails program funding without jeopardizing the project's eligibility for funding approval, but does not imply or guarantee that the commission will commit recreational trails program funding to a subsequent application.

**165.19(2)** *Request, justification and review.* The request must be received by the department prior to the expenditure and must include justification regarding the extreme urgency and necessity to incur costs prior to a recreational trails program funding commitment. A request for land acquisition must also include a description of the land to be acquired, a summary of the estimated costs, and a map showing the parcels to be acquired. Preliminary design requests must include a description of the project scope, location map, and proposed cross section. If the request will include consultant design costs, a draft agreement between the jurisdiction and the consultant must be submitted which includes the scope of services to be rendered. Costs for recreational trails program application preparation and submission or project feasibility, route alignment studies or other planning expenses as cited in paragraphs 165.17(2) "c" and "d" remain ineligible for recreational trails program funding and shall not be included in a request for determination of advance eligibility. The department will review the submittal. If the requirements of this rule are met, the department will provide written confirmation of the determination of advance eligibility.

**165.19(3)** *Requirements.* Any cost incurred before the request is received by the department will be ineligible for reimbursement. Costs receiving a determination of advance eligibility must be noted in the subsequent recreational trails program funding application submitted to the department. Land acquired or design work completed following a determination of advance eligibility will not be eligible for reimbursement with recreational trails program funds if the property acquired or design work completed is not necessary to construct the proposed recreational trails program project included in the subsequent application. Design costs receiving a determination of advance eligibility may not exceed 10 percent of the total construction costs for the project. An application for funding which includes the expenditure must be received by the department within two years following the determination of advance eligibility, or the costs may become ineligible for recreational trails program funding.

[ARC 3300C, IAB 8/30/17, effective 10/4/17]

**761—165.20** and **165.21** Reserved.

**761—165.22(465B) Application.**

**165.22(1)** *Submission.* An eligible applicant shall complete and submit an application on a form and in the quantity prescribed by the department.

- a. An eligible applicant may submit more than one application in a funding cycle.
- b. Two or more eligible applicants may submit a joint application and are encouraged to do so when a project requires mutual action. A joint application shall designate a lead applicant to serve as the principal contact with the department.
- c. The application deadline shall be on the first day of the fiscal year for which funding has been provided to the program and any additional stated deadline as deemed necessary by the department to fully award program funding.
- d. Applications shall be received by the department or postmarked by the stated application deadline.

**165.22(2)** *Contents of application.* Each application shall contain the following:

- a. The applicant's name, mailing address and telephone number, and the contact person who will serve as liaison with the department.

b. A project concept statement including a location map, a cross section and a sketch of the project intended to be constructed with program funds. The proposed project need not be designed before applying, but the concept must be reasonable from a transportation engineering standpoint and detailed enough to generate project cost estimates.

c. An itemized cost estimate for the total project to be constructed showing for each item the cost and funding source. When a project is part of a larger multiphase project, the application shall differentiate the costs and scope of the proposed construction project from the costs and scope of the overall multiphase project.

d. A time schedule for project completion. A time schedule adjustment may be approved by the department if the project involves unusually complex studies, extensive real estate negotiations, extensive analyses for environmental clearances, complex planning for associated developments, or another compelling reason.

e. An adequate justification for the recreational trails project based on the project eligibility criteria in subrule 165.12(2) and the evaluation criteria in subrule 165.26(2).

f. A formal resolution passed by the governing body of the responsible authority endorsing the application and the timeline for project completion provided therein. The resolution shall also state that the proposed trail project will be adequately maintained and made available for the intended public use for a minimum of 20 years after completion of the project.

**165.22(3) Funding requests.** An applicant shall specify in the application the amount of grant funding requested from the recreational trails program and may offer a matching fund contribution larger than is required.

[ARC 3300C, IAB 8/30/17, effective 10/4/17]

#### **761—165.23(465B) Application procedure.**

**165.23(1)** All applications for funding shall be complete. The department reserves the right to return an incomplete application to the applicant without further consideration for funding. An applicant may then submit a completed application for the next available funding cycle.

**165.23(2)** An application that is considered but not funded in one funding cycle may be resubmitted by the applicant for consideration in the next cycle.

**165.23(3)** An applicant may withdraw an application at any time.

[ARC 3300C, IAB 8/30/17, effective 10/4/17]

**761—165.24 and 165.25** Reserved.

#### **761—165.26(465B) Evaluation and approval.**

**165.26(1)** The department shall review each application, may verify the contents and may visit the trail site.

**165.26(2)** The department shall evaluate each complete application primarily on the basis of whether the predicted use of the trail justifies the construction and maintenance costs including, but not limited to, the following criteria:

- a. Need, in terms of the population to be served and existing trails in the area (25 points).
- b. Compatibility with local, areawide, regional or statewide plans (15 points).
- c. Benefits of multiple uses and recreational opportunities (20 points).
- d. Quality of the site (25 points).
- e. Economic benefits to the local area (10 points).
- f. Special facilities for persons with disabilities (5 points).
- g. Project is shovel-ready and planned to be completed within three years of award of funding (25 points).
- h. Projects with cash match (5 points).

**165.26(3)** Completed applications shall be reviewed by a committee composed of one representative from state agencies with jurisdiction over transportation, tourism, cultural resources and natural resources. The committee shall recommend applications to the department by ranking them in order of funding priority.

**165.26(4)** The department shall prepare a list of applications and funding recommendations and present it to the commission for final approval and award of funding.

[ARC 3300C, IAB 8/30/17, effective 10/4/17]

**761—165.27 to 165.29** Reserved.

#### **761—165.30(465B) Project agreement.**

**165.30(1)** After the commission has approved funding for a recreational trails project, the department and the applicant shall execute a project agreement.

*a.* The agreement shall specify the responsibilities for project planning, design, land acquisition, contracting, construction and materials inspection, and documentation and the criteria for each. The agreement shall also specify the overall funding level approved and contain an estimated budget for eligible work items.

*b.* The agreement shall require the applicant to comply with all local, state and federal laws, rules and regulations that may apply to the project.

**165.30(2)** The department shall reimburse the authority for actual eligible project costs incurred as specified in the agreement, not to exceed the amounts authorized by the project agreement.

**165.30(3)** Project expenditures incurred after the commission has made a funding commitment, but before execution of the agreement, are eligible for reimbursement if a project agreement is subsequently executed. However, under no circumstances shall any reimbursement be paid until the project agreement has been executed.

**165.30(4)** The department may audit all project costs incurred for compliance with the agreement, including costs that are part of the matching contribution. All force account work performed by a county or city on the project shall be audited.

[ARC 3300C, IAB 8/30/17, effective 10/4/17]

**761—165.31 and 165.32** Reserved.

**761—165.33(465B) Noncompliance.** The department may revoke funding commitments, seek repayment of funds already reimbursed, or take both actions if:

**165.33(1)** The terms of the project agreement have not been fulfilled.

**165.33(2)** An agreement has not been signed within six months after the project sponsor receives the signature copy.

**165.33(3)** The department finds that the application contained inaccuracies, omissions, errors or misrepresentations.

**165.33(4)** The time schedule for project completion was misrepresented or has not been maintained.

**165.33(5)** The authority fails to comply with subrule 165.22(2), paragraph “f.”

[ARC 3300C, IAB 8/30/17, effective 10/4/17]

These rules are intended to implement Iowa Code chapter 465B.

[Filed emergency 1/12/89—published 2/8/89, effective 1/13/89]

[Filed 5/18/89, Notice 2/8/89—published 6/14/89, effective 7/19/89]

[Filed 10/15/92, Notice 8/5/92—published 11/11/92, effective 12/16/92]

[Filed 3/10/94, Notice 2/2/94—published 3/30/94, effective 5/4/94]

[Filed emergency 6/28/94—published 7/20/94, effective 7/1/94]

[Filed emergency 11/28/94—published 12/21/94, effective 11/28/94]

[Filed ARC 3300C (Notice ARC 3132C, IAB 6/21/17), IAB 8/30/17, effective 10/4/17]

[Editorial change: IAC Supplement 8/11/21]



CHAPTERS 166 to 169

Reserved  
*LOCAL SYSTEMS*

CHAPTER 170

ALLOCATION OF FARM-TO-MARKET ROAD FUNDS

[Prior to 6/3/87, Transportation Department[820]—(06,Q) Ch 16]  
Rescinded **ARC 8243C**, IAB 10/2/24, effective 11/6/24

CHAPTER 171

Reserved

CHAPTER 172

AVAILABILITY OF INSTRUCTIONAL MEMORANDUMS  
TO LOCAL PUBLIC AGENCIES

[Prior to 6/3/87, Transportation Department[820]—(06,Q) Ch 1]  
Rescinded **ARC 8243C**, IAB 10/2/24, effective 11/6/24

CHAPTER 173

PREPARATION OF SECONDARY ROAD CONSTRUCTION PROGRAMS,  
BUDGETS, AND COUNTY ANNUAL REPORTS

[Prior to 6/3/87, Transportation Department[820]—(06,Q) Ch 2]  
Rescinded **ARC 8243C**, IAB 10/2/24, effective 11/6/24

CHAPTER 174

REIMBURSABLE SERVICES AND SUPPLIES

[Prior to 6/3/87, Transportation Department[820]—(06,Q) Ch 9]  
Rescinded **ARC 8243C**, IAB 10/2/24, effective 11/6/24

CHAPTERS 175 to 177

Reserved



CHAPTER 178  
PROJECT COST REPORTING REQUIREMENTS  
FOR CITIES AND COUNTIES

**761—178.1(314) Purpose.** The purpose of these rules is to establish requirements for the reporting by cities and counties of project cost information to the department, in accordance with Iowa Code section 314.1A.

[ARC 2425C, IAB 3/2/16, effective 4/6/16]

**761—178.2(314) Contact information.** Questions regarding this chapter may be directed to the Office of Local Systems, Iowa Department of Transportation, 800 Lincoln Way, Ames, Iowa 50010.

**761—178.3(314) Definitions.**

“*City*” means a municipal corporation as defined in Iowa Code section 312.8 or 362.2.

“*Construction*” means the building or development of a road, street, bridge or culvert in a new location when:

1. The new location deviates substantially from the existing alignment, and
2. The result is an entirely new road or street for the greater part of the length of the project.

“*Day labor*” means road, street, bridge or culvert work performed by permanent or temporary city or county employees.

“*Improvement*” means a betterment to a road, street, bridge or culvert. The work increases the value of the facility and enhances the facility, its traffic operations or its safety beyond the original design. The work would not be so extensive as to be classified as construction or reconstruction, but it could involve rehabilitation, restoration or resurfacing (3R) work.

“*Reconstruction*” means a significant change to the existing type of road, street, bridge or culvert or its geometric or structural features. Some realignment and the use of current design criteria may be involved.

“*Repair or maintenance*” means the preservation of a road, street, bridge or culvert so that it is in sound or proper condition. The work may include minor replacements and additions necessary to restore the road, street, bridge or culvert to its originally built condition with essentially the same design.

[ARC 2425C, IAB 3/2/16, effective 4/6/16]

**761—178.4(314) Detailed instructions furnished to cities and counties.**

**178.4(1)** Each year the department shall provide to cities and counties a set of detailed instructions for reporting the following information:

- a. The cost of day labor and contracts for construction, reconstruction, and improvement projects on the farm-to-market, secondary road and municipal street systems.
- b. The cost of purchasing, leasing, and renting construction and maintenance equipment.
- c. The use of this equipment for construction, reconstruction, and improvement projects on the farm-to-market, secondary road and municipal street systems.

**178.4(2)** These instructions constitute the form, content and method of preparation acceptable to the department. Cities and counties shall include this information in the annual reports they submit to the department under Iowa Code sections 309.22 and 312.14.

[ARC 2425C, IAB 3/2/16, effective 4/6/16]

**761—178.5(314) Project reporting.** Reporting under Iowa Code section 314.1A of projects accomplished by day labor or contract is required for any construction, reconstruction or improvement project that has a total cost of 90 percent or more of the applicable bid threshold. Other reporting requirements set out in the Iowa Code still apply.

**178.5(1) Types of projects.** Project type shall be identified. The project types are:

a. *Bridge.* The definition of “bridge” in Iowa Code section 309.1 applies. This project type includes removal of existing structures and all new construction, reconstruction and improvement of bridges.

b. *Culvert.* The definition of “culvert” in Iowa Code section 309.1 applies. This project type includes new construction or installation of an individual box or pipe culvert with a span or diameter that is greater than four feet but no greater than 20 feet.

c. *Roadway construction.* This project type includes, but is not limited to, all types of excavation, overhaul, clearing and grubbing, removal of pavement, and culverts included with grading.

d. *Surfaces.* This type includes, but is not limited to:

- (1) Hot mix asphalt and Portland cement concrete pavements and overlays on roads, streets and shoulders.
- (2) Stabilized bases and granular surfacing on new grades.

e. *Roadside construction.* This project type includes, but is not limited to:

- (1) Erosion control structures such as check dams and letdown structures.
  - (2) Landscape treatments such as seedbed preparation, seeding, sodding, mulching, fertilizing, and planting of shrubs and trees on newly graded roads.
  - (3) Construction of shoulders on paved roads and rebuilding or raising entrances due to shoulder construction.
- f. Traffic control.* This project type includes, but is not limited to, installation of major signs, traffic signals, railroad crossing signals, guardrail, roadway lighting, construction signing, and pavement markings on newly paved roads and streets.
- g. Miscellaneous.* This project type includes, but is not limited to, construction, reconstruction, or installation of storm sewers, subdrains, retaining walls, noise barriers, and sidewalks.

**178.5(2)** *Contract work.* The cost of contract work on a project is the contract price plus additions and deductions.

**178.5(3)** *Day labor.* The cost of day labor on a project shall include the following expenditures:

- a. Labor.* Labor cost includes the wages of city or county employees for their time devoted to the project, plus corresponding fringe benefits such as, but not limited to, IPERS, FICA and insurance.
- b. Equipment.* Equipment cost is calculated based on the equipment used on the project and the time the equipment is used. If an item of equipment is rented or leased, its rental or lease rate may be used to calculate cost. If an item of equipment is not leased, its cost shall be calculated using the standard rate established by the department for that type of equipment. The department shall establish equipment rates each year based on the latest "Rental Rate Blue Book for Construction Equipment."
- c. Materials.* Materials cost is the cost of materials and supplies consumed or expended on the project. The materials and supplies may be procured directly for the project or charged to the project from stock on hand. The cost of used material is its salvage value.
- d. Overhead.* Overhead cost is the pro-rata share of indirect costs to be allocated to day labor projects. Indirect costs are the city's or county's road- or street-related costs that cannot be charged directly to any project. The city or county may use its records to calculate the cost of overhead, or it may use a standard overhead rate of 10 percent of the labor cost excluding fringe benefits.

[ARC 2425C, IAB 3/2/16, effective 4/6/16]

These rules are intended to implement Iowa Code sections 309.22, 309.93, 312.14, 314.1, and 314.1A.

[Filed 2/15/02, Notice 12/26/01—published 3/20/02, effective 7/1/02]

[Filed ARC 2425C (Notice ARC 2319C, IAB 12/23/15), IAB 3/2/16, effective 4/6/16]

CHAPTER 179  
Reserved



CHAPTER 180  
QUOTATION PROCESS FOR GOVERNMENTAL ENTITIES FOR PUBLIC IMPROVEMENT FOR  
VERTICAL INFRASTRUCTURE

**761—180.1(314) Purpose.** The purpose of these rules is to prescribe the manner by which governmental entities shall administer competitive quotations for contracts pertaining to a public improvement for vertical infrastructure, in accordance with Iowa Code section 26.14.

[ARC 3448C, IAB 11/8/17, effective 12/13/17; ARC 6705C, IAB 11/30/22, effective 1/4/23]

**761—180.2(314) Contact information.** Questions regarding this chapter may be directed to the Support Services Bureau, Iowa Department of Transportation, 800 Lincoln Way, Ames, Iowa 50010; telephone (515)239-1299.

[ARC 3448C, IAB 11/8/17, effective 12/13/17; ARC 5493C, IAB 3/10/21, effective 4/14/21]

**761—180.3(26,314) Definitions.**

*“Estimated total cost”* means the same as defined in Iowa Code section 26.2.

*“Governmental entity”* means the same as defined in Iowa Code section 26.2.

*“Public improvement for vertical infrastructure”* is a “public improvement” as defined in Iowa Code section 26.2(3) “a” and “b” but excludes those improvements in Iowa Code section 26.2(3) “b”(1) to (6).

*“Responsible quotation”* means a quotation submitted by a contractor who is capable of performing the work. To be considered responsible, the contractor must possess the necessary financial and technical capability to perform the work, as well as the ability to complete the work as demonstrated by past performance or other appropriate considerations.

*“Responsive quotation”* means a quotation in which the contractor agrees to do everything required by the governmental entity’s solicitation of quotations and by the plans and specifications and other related documents without any conditions, qualifications or exclusions.

[ARC 3448C, IAB 11/8/17, effective 12/13/17; ARC 5493C, IAB 3/10/21, effective 4/14/21; ARC 6705C, IAB 11/30/22, effective 1/4/23]

**761—180.4(314) Types of projects.** Rescinded ARC 6705C, IAB 11/30/22, effective 1/4/23.

**761—180.5(314) Solicitation of quotations.**

**180.5(1)** A governmental entity shall solicit competitive quotations for a public improvement for vertical infrastructure when the estimated total cost of the public improvement for vertical infrastructure exceeds the competitive quotation threshold established in Iowa Code section 26.14, as adjusted pursuant to Iowa Code section 314.1B, but is less than the competitive bid threshold established in Iowa Code section 26.3, as adjusted pursuant to Iowa Code section 314.1B. The adjusted thresholds are published on the department’s website at [www.iowadot.gov](http://www.iowadot.gov).

**180.5(2)** The governmental entity shall make a good-faith effort to obtain quotations for the work from at least two contractors regularly engaged in such work prior to letting a contract. Quotations shall be obtained by means of either an oral or a written solicitation directed to not less than two contractors.

**180.5(3)** Each solicitation shall include a description of the work to be performed, and plans and specifications for the work prepared by an architect or engineer if required by Iowa Code chapter 542B or 544A. (See 193B—Chapter 5 or rule 193C—1.5(542B) for additional guidelines.) In its solicitation, the governmental entity shall advise each contractor that it has an opportunity to inspect the work site. Each contractor requesting to inspect the work site shall be provided an equal and adequate opportunity to do so.

**180.5(4)** Additional information deemed pertinent by the governmental entity, or requested by a contractor, may be provided by the governmental entity if the same information is provided to all contractors from which quotations are solicited. If the information is provided in written form to a contractor, it shall be provided in the same form to all contractors from which quotations are solicited.

**180.5(5)** In its solicitation, the governmental entity shall:

- a. Specify the required form and content of quotations. (See rule 761—180.7(314).)
- b. Require that quotations be filed by a particular time, at a particular location and with a particular office or representative of the governmental entity.
- c. Establish the acceptable method(s) for delivery of quotations. The governmental entity may specify any or all of the following methods of delivery: mail, facsimile, electronic mail, or delivery in-hand.

**180.5(6)** As required by Iowa Code section 573.2, the governmental entity shall in its solicitation inform quoting contractors of the obligation of the contractor awarded the contract to provide a performance and payment bond to secure the performance and timely completion of the work and to secure the payment of subcontractors and suppliers.

**180.5(7)** In its solicitation, the governmental entity may require each quoting contractor to:

*a.* Provide along with its quotation a quotation bond, or other quotation security or evidence of its responsibility, to assure that it will enter into a contract to perform the work and that it will provide the required performance and payment bond.

*b.* Commit to the execution of a contract for the work in a form required by the governmental entity.

*c.* Commit to commencement and completion dates for the work as directed by the governmental entity.

*d.* File evidence of insurance, as specified by the governmental entity, with its quotation, or commit to filing such evidence of insurance upon award of the contract to perform the work.

**180.5(8)** In its solicitation, the governmental entity may provide that it will issue special sales tax exemption certificates to contractors and subcontractors, pursuant to Iowa Code section 423.3, subsection 80.

[ARC 3448C, IAB 11/8/17, effective 12/13/17; ARC 6705C, IAB 11/30/22, effective 1/4/23]

**761—180.6(314) Submission of competitive quotation by governmental entity.** The governmental entity may itself file a competitive quotation to perform the work. The governmental entity's quotation shall be filed in the same manner as it requires quotations to be filed by contractors except as provided in subrule 180.7(3).

**761—180.7(314) Form and content of competitive quotations.**

**180.7(1)** A competitive quotation filed by a contractor or by the governmental entity shall be in writing and shall include the total price for labor, equipment, materials and supplies required to perform the work. A contractor shall not be required to include in its quotation or in individual quotation items a breakdown of costs for labor, materials, equipment and supplies. Competitive quotations filed by contractors shall include all other information, documentation or commitments required by the governmental entity in its solicitation of quotations.

**180.7(2)** If the governmental entity in its solicitation indicates its intention to file a competing quotation, contractors shall also separately identify in their quotations the premium cost for the required performance and payment bond and an estimate of the sales and fuel taxes they will incur in performing the work. However, if in its solicitation the governmental entity provides for the issuance of sales tax exemption certificates to the contractor and subcontractors performing the work, quoting contractors shall not include or separately identify estimated sales tax in their quotations.

**180.7(3)** A quotation submitted by a governmental entity need not include the information, documents or commitments required of quoting contractors in subrule 180.5(7). A governmental entity is not required to submit a performance and payment bond.

**180.7(4)** The governmental entity may require that quotations from contractors be submitted on a form prescribed by the governmental entity, provided the form complies with the requirements of these rules.

**761—180.8(314) Evaluation of competitive quotations.**

**180.8(1)** If a quoting contractor does not file a quotation in the form required by the governmental entity, or does not provide all information or documentation or make all commitments required by the governmental entity, or does not sign the quotation if required by the governmental entity, the quotation shall be determined to be nonresponsive and shall be rejected by the governmental entity.

**180.8(2)** If the governmental entity submits a quotation to perform the work, paragraphs "a" to "c" of this subrule are applicable. If the governmental entity does not submit a quotation, these paragraphs do not apply.

*a.* Because the governmental entity is not required to pay sales tax or fuel tax or to submit a performance and payment bond in connection with work performed by governmental employees using governmental equipment, each contractor's total quotation shall be adjusted to deduct the amounts identified in the quotation for estimated sales and fuel taxes and the bond premium. The amount of each contractor's adjusted quotation shall then be compared to the amount of the quotation submitted by the governmental entity for the purpose of determining if the governmental entity's quotation is the lowest responsive, responsible quotation.

*b.* If in its solicitation the governmental entity provides for the issuance of sales tax exemption certificates to the contractor and subcontractors performing the work, quoting contractors shall not include or separately identify estimated sales tax in their quotations, and the governmental entity shall not deduct estimated sales tax from the contractors' quotations for the purpose of determining if the governmental entity's quotation is the lowest responsive, responsible quotation.

*c.* The governmental entity may require the contractor to which the work is awarded to provide documentation of the premium cost incurred by it for the performance and payment bond and of all sales and fuel taxes paid by it and its subcontractors in connection with the work. The governmental entity may decline to pay the amounts identified by the contractor in its quotation for the bond premium and estimated sales and fuel taxes if these amounts are not properly documented as having been paid.

**761—180.9(314) Award of contract and subsequent procedures.**

**180.9(1)** Except as provided in subrule 180.9(3), the governmental entity shall award the contract for the work to the contractor submitting the lowest responsive, responsible quotation, subject to Iowa Code section 26.9, or the governmental entity may reject all of the quotations. A contract shall be considered awarded when the governmental entity unconditionally accepts and approves the lowest responsive, responsible quotation. The governing body of the governmental entity shall record the approved quotation in its meeting minutes.

**180.9(2)** The governing body of a governmental entity may delegate the authority to award and execute contracts, or to award contracts and authorize the work to proceed, to an officer or employee of the governmental entity, provided that an award approved outside a meeting of the governing body shall be reported in the meeting minutes of the next regular meeting of the governing body.

**180.9(3)** If no quotations are received from contractors to perform the work or if the governmental entity's estimated cost to do the work with its employees, as reflected in its quotation, is less than the lowest responsive, responsible quotation received from a contractor, the governmental entity may authorize its employees to perform the work.

**180.9(4)** Upon the submission of the required performance and payment bond by the contractor to which the contract has been awarded and upon approval of the bond by the governmental entity, the governmental entity shall execute a contract to perform the work or shall authorize the contractor to proceed with the work.

**180.9(5)** Upon execution of the contract by the contractor and the governmental entity or upon authorization to proceed by the governmental entity and acknowledgment thereof by the contractor, the governmental entity shall release the quotation bonds or other quotation security submitted with the quotations received.

**180.9(6)** If the governmental entity is a city and the cost of the work will exceed the amount provided for in Iowa Code section 380.4, the governing body is required to pass a resolution approving the expenditure.

**761—180.10(314) Retained funds.** In addition to requiring the contractor to submit a performance and payment bond, the governmental entity shall also retain funds from each payment to the contractor for the benefit of subcontractors and suppliers, and apply or release such funds, as required by Iowa Code chapter 573.

[ARC 4342C, IAB 3/13/19, effective 4/17/19]

These rules are intended to implement Iowa Code sections 26.2, 26.14, 314.1A, 314.1B, 573.2, and 573.28.

[Filed 4/16/07, Notice 2/28/07—published 5/9/07, effective 6/13/07]

[Filed ARC 3448C (Notice ARC 3269C, IAB 8/30/17), IAB 11/8/17, effective 12/13/17]

[Filed ARC 4342C (Notice ARC 4228C, IAB 1/16/19), IAB 3/13/19, effective 4/17/19]

[Filed ARC 5493C (Notice ARC 5375C, IAB 1/13/21), IAB 3/10/21, effective 4/14/21]

[Filed ARC 6705C (Notice ARC 6576C, IAB 10/5/22), IAB 11/30/22, effective 1/4/23]



CHAPTER 181  
STATEWIDE STANDARD FOR PERMITTING  
CERTAIN IMPLEMENTS OF HUSBANDRY

**761—181.1(321) Statewide standard.**

**181.1(1)** Special permits.

*a.* A local authority may issue a special permit, based on this rule, allowing the operation over a bridge within its jurisdiction of a fence-line feeder, grain cart, tank wagon or tracked implement of husbandry with a weight in excess of the weights allowed under Iowa Code chapter 321.

*b.* A local authority may issue a special permit, based on this rule, allowing the operation over a bridge within its jurisdiction of a self-propelled implement of husbandry used exclusively for the application of organic or inorganic plant food materials, agricultural limestone or agricultural chemicals with a weight in excess of weight limitations established by the local authority by ordinance or resolution but within the weight limitations imposed by Iowa Code chapter 321.

**181.1(2)** A local authority shall evaluate a bridge according to section 6 of the American Association of State Highway and Transportation Officials (AASHTO) Manual for Bridge Evaluation (MBE), Third Edition (2018). The operating level shall be used for the evaluation of the bridge with only one fence-line feeder, grain cart, tank wagon, self-propelled implement of husbandry as fully described in paragraph 181.1(1)“*b*,” or tracked implement of husbandry on the bridge at a time. The live load to be used in the analysis for permit decisions should be the actual vehicle crossing the bridge, together with a dynamic load allowance in accordance with section 6A.4.4.3 or 6A.4.5.5 of the AASHTO MBE, Third Edition (2018).

**181.1(3)** A local authority is not liable for damage to any vehicle operating within the terms of a permit the local authority issues under this rule, or to the vehicle’s cargo, if the local authority imposes weight limits on a bridge specified in the permit subsequent to the issuance of the permit. The weight limits are effective when signs giving notice of the limits are erected.

**181.1(4)** The AASHTO publication may be ordered from the website [www.transportation.org](http://www.transportation.org). The publication may be inspected at the department’s bridges and structures bureau.

This rule is intended to implement Iowa Code sections 321.1, 321.463(4) and 321.471.

[ARC 1451C, IAB 4/30/14, effective 6/4/14; ARC 4400C, IAB 4/10/19, effective 5/15/19; ARC 5202C, IAB 10/7/20, effective 11/11/20]

[Filed 10/24/01, Notice 9/19/01—published 11/14/01, effective 12/19/01]

[Filed ARC 1451C (Notice ARC 1350C, IAB 3/5/14), IAB 4/30/14, effective 6/4/14]

[Filed ARC 4400C (Notice ARC 4257C, IAB 1/30/19), IAB 4/10/19, effective 5/15/19]

[Filed ARC 5202C (Notice ARC 5081C, IAB 7/15/20), IAB 10/7/20, effective 11/11/20]



CHAPTERS 182 to 200  
Reserved

CHAPTER 201  
INTERMODAL PILOT PROJECT PROGRAM  
Rescinded **ARC 6488C**, IAB 9/7/22, effective 10/12/22

CHAPTERS 202 to 300  
Reserved



## VEHICLES

## CHAPTER 301

## DRIVER'S PRIVACY PROTECTION—MOTOR VEHICLE RECORDS

**761—301.1(321) Applicability.** This chapter applies to personal information and highly restricted personal information in records pertaining to driver's licenses, nonoperator's identification cards, and personal information and highly restricted personal information about vehicle owners in records pertaining to certificates of title, registration receipts and registration renewal receipts issued by the department or a county treasurer. In addition to information on current licensees and cardholders, motor vehicle records include information on individuals who do not currently hold a driver's license or nonoperator's identification card, including, but not limited to, operating records and records of driver sanctions.

This rule is intended to implement Iowa Code section 321.11 and 18 U.S.C. §2721 et seq.  
[ARC 6060C, IAB 12/1/21, effective 1/5/22]

**761—301.2(321) Adoption.** The department adopts the Driver's Privacy Protection Act of 1994 (18 U.S.C. §2721 et seq.) for motor vehicle records.

This rule is intended to implement Iowa Code section 321.11 and 18 U.S.C. §2721 et seq.  
[ARC 6060C, IAB 12/1/21, effective 1/5/22]

**761—301.3(321) Definitions.**

*"Certified abstract of operating record"* means the same as described in Iowa Code section 321A.3(1).

*"Driver's license"* means the same as defined in Iowa Code section 321.1(20A).

*"Driver's Privacy Protection Act"* means the Act adopted in rule 761—301.2(321).

*"Highly restricted personal information"* means an individual's photograph or image, social security number, or medical or disability information.

*"Law enforcement agency"* includes, but is not limited to, county attorneys, federal district attorneys, attorneys general, state and federal departments of justice, and a division or unit of a governmental agency if the division's or unit's primary responsibility is to prevent or detect crime or enforce criminal laws.

*"Motor vehicle record"* as used in the Driver's Privacy Protection Act means any record that pertains to a driver's license, nonoperator's identification card, certificate of title, registration receipt, or registration renewal receipt issued by the department or a county treasurer.

*"Person"* means an individual, organization or entity.

*"Personal information"* means information that identifies an individual, including the items listed in Iowa Code section 321.11 and 18 U.S.C. §2725 of the Driver's Privacy Protection Act adopted in rule 761—301.2(321). "Personal information" also includes information on an individual's nonoperator's identification card.

*"Requester"* means an individual, organization or entity that seeks from the department access to personal information or highly restricted personal information contained in the individual's own or another individual's motor vehicle record. A requester does not include an individual who is an authorized employee of the department or a county treasurer acting within the scope of the employee's office or employment.

*"Sanction"* means the same as defined in rule 761—615.1(321).

*"Vehicle owner"* as used in this chapter means a vehicle owner who is an individual, not a company, organization or other legal entity.

This rule is intended to implement Iowa Code section 321.11 and 18 U.S.C. §2721 et seq.  
[ARC 6060C, IAB 12/1/21, effective 1/5/22]

**761—301.4(17A) Information and addresses.** Information and forms for records pertaining to motor vehicle records may be obtained at any driver's license service center or by mail from the Motor Vehicle Division, Iowa Department of Transportation, P.O. Box 9278, Des Moines, Iowa 50306-9278; in person at 6310 SE Convenience Blvd., Ankeny, Iowa; by telephone at (515)237-3110; by email at [privacy.agreements@iowadot.us](mailto:privacy.agreements@iowadot.us); or on the department's website at [www.iowadot.gov](http://www.iowadot.gov).

This rule is intended to implement Iowa Code section 17A.3.  
[ARC 6060C, IAB 12/1/21, effective 1/5/22]

**761—301.5(321) Requirements and procedures.** Notwithstanding Iowa Code chapter 22 and 761—Chapter 4, the following procedures implement the Driver's Privacy Protection Act and Iowa Code section 321.11 as the provisions pertain to access to records related to driver's licenses, nonoperator's identification cards, certificates of title,

registration receipts and registration renewal receipts. The department does not provide the waiver procedure described in the Driver's Privacy Protection Act (codified as 18 U.S.C. §2721(d)).

**301.5(1)** The department shall require a requester who requests personal information or highly restricted personal information about another individual to:

*a.* Complete Form 431069, "Privacy Act Agreement for Request of Motor Vehicle Records," and submit the form to any driver's license service center or the motor vehicle division at the address in rule 761—301.4(17A).

*b.* Provide proof of identity and authority to access the information by completing Form 431069, "Privacy Act Agreement for Request of Motor Vehicle Records," and including a legible photocopy of the requester's driver's license or nonoperator's identification card.

*c.* Provide proof of authority to secure access to the personal information or highly restricted personal information by completing Part C of Form 431069, "Privacy Act Agreement for Request of Motor Vehicle Records," and providing the department with proof of the requester's status or other additional information the department may request.

*d.* Complete the certification on Part D of Form 431069, "Privacy Act Agreement for Request of Motor Vehicle Records," and provide any proof necessary to establish relevant facts.

**301.5(2)** The department shall require a law enforcement agency that requests personal information or highly restricted personal information about another individual to either follow the process in subrule 301.5(1) or complete and submit Form 431200, "Certified Motor Vehicle Record Request Form for Use by County Attorney's Offices and Law Enforcement Agencies," to any driver's license service center or the motor vehicle division at the address in rule 761—301.4(321). Nothing in this subrule shall preclude a law enforcement agency from completing and submitting Form 431069 or from entering into a memorandum of understanding with the department for the purposes of requesting personal information or highly restricted personal information.

**301.5(3)** The department shall require a requester who requests personal information or highly restricted personal information about themselves to either:

*a.* Complete and submit Part A of Form 431069, "Privacy Act Agreement for Request of Motor Vehicle Records," including a photocopy of the requester's driver's license or nonoperator's identification card to any driver's license service center or the motor vehicle division at the address in rule 761—301.4(321).

*b.* Provide valid proof of the requester's identity to any driver's license service center or the motor vehicle division at the address in rule 761—301.4(321).

**301.5(4)** Personal information and highly restricted personal information, except for an individual's photograph or image, may be disclosed with the express written consent of the individual or vehicle owner to whom such information applies. When the requester has obtained the written consent of the individual or vehicle owner to whom the information applies, the requester must attach that written consent on a completed Form 431069, "Privacy Act Agreement for Request of Motor Vehicle Records," and submit the form to any driver's license service center or the motor vehicle division at the address in rule 761—301.4(321). An individual's signature on the document providing express written consent allowing disclosure of the individual's personal information to another person must be notarized, or in the alternative, the signed written consent document must be accompanied by a copy of the individual's driver's license or nonoperator's identification card.

**301.5(5)** The statutory fee, if applicable, shall accompany the request for a motor vehicle record.

**301.5(6)** The department shall not release any personal information or highly restricted personal information if the request is made by plate number or validation sticker number, except as provided in Iowa Code section 321.11.

**301.5(7)** All requesters who obtain personal information or highly restricted personal information from the department are required to comply with Iowa Code section 321.11 and the Driver's Privacy Protection Act.

**301.5(8)** The department may transmit records to an authorized requester under this chapter by email.

This rule is intended to implement Iowa Code sections 321.10 and 321.11 and 18 U.S.C. §2721 et seq.

[ARC 6060C, IAB 12/1/21, effective 1/5/22]

**761—301.6(321) Electronic motor vehicle records files.** Motor vehicle records files may be made available electronically to authorized requesters under the Driver's Privacy Protection Act upon approval by the department and upon payment of any applicable fees. The department may require the requester to complete and submit Form 431069, "Privacy Act Agreement for Request of Motor Vehicle Records," or Form 431200, "Certified Motor Vehicle Record Request Form for Use by County Attorney's Offices and Law Enforcement Agencies," to any driver's license service center or the motor vehicle division at the address in rule 761—301.4(321), including any required attachments, or may enter into a memorandum of understanding governing the terms of accessing the motor vehicle records files electronically.

This rule is intended to implement Iowa Code section 321.11 and 18 U.S.C. §2721 et seq.

[ARC 6060C, IAB 12/1/21, effective 1/5/22]

**761—301.7(321,321A) Certified abstract of operating records.**

**301.7(1)** In accordance with Iowa Code section 321A.3, a certified abstract of the operating record of an individual is available. The record includes the information that is on the face of the individual's driver's license, plus information on the individual's sanctions, reportable vehicle accidents, and convictions. The certified abstract of operating record does not include the individual's photograph, social security number, or medical or disability information.

**301.7(2)** To obtain a certified abstract of an operating record of another individual, a requester shall complete Form 431069, "Privacy Act Agreement for Request of Motor Vehicle Records," and submit the form to any driver's license service center or the motor vehicle division at the address in rule 761—301.4(17A). Form 431069 must be completed with all required attachments before the department will process a request for a certified abstract of an operating record of another individual. A requester must attach a legible photocopy of the requester's driver's license or nonoperator's identification card to the form.

*a.* Personal information and highly restricted personal information protected by Iowa Code section 321.11 and the Driver's Privacy Protection Act may be released only if all of the following apply:

(1) The requester has complied with each of the following requirements:

1. Completed and submitted Form 431069, "Privacy Act Agreement for Request of Motor Vehicle Records," including proof of authority to secure access to the personal information or highly restricted personal information.

2. Included all required attachments with the form, including a photocopy of the requester's driver's license or nonoperator's identification card.

3. Paid the statutory fee by the methods permitted under Iowa Code section 321A.3, if applicable, for the requested record.

(2) The department is satisfied with the genuineness, regularity, and legality of the application and in any statement made within the application and in any required attachments.

*b.* Reserved.

**301.7(3)** The department shall require a law enforcement agency that requests a certified abstract of an operating record to complete to either follow the process in subrule 301.7(2) or submit Form 431200, "Certified Motor Vehicle Record Request Form for Use by County Attorney's Offices and Law Enforcement Agencies," to any driver's license service center or the motor vehicle division at the address in rule 761—301.4(321). Nothing in this subrule shall preclude a law enforcement agency from completing and submitting Form 431069 or from entering into a memorandum of understanding with the department for the purposes of requesting information under this rule.

**301.7(4)** The department shall require a requester seeking the requester's own operating record to either:

*a.* Complete and submit Part A of Form 431069, "Privacy Act Agreement for Request of Motor Vehicle Records," including a photocopy of the requester's driver's license or nonoperator's identification card to any driver's license service center or the motor vehicle division at the address in rule 761—301.4(321).

*b.* Provide valid proof of the requester's identity to any driver's license service center or the motor vehicle division at the address in rule 761—301.4(321).

**301.7(5)** The statutory fee, if applicable, shall accompany the request for a certified abstract of the operating record. There is no fee for an individual to view the individual's own operating record. Pursuant to the authority in Iowa Code section 321A.3, the department shall comply with the requirements of 781—Chapter 8 for payments accepted by credit card.

**301.7(6)** The single-use restriction in Iowa Code section 321A.3(8) applies only to the certified abstract of operating records and to persons who are subject to the fee listed in Iowa Code section 321A.3(1).

**301.7(7)** Any person who obtains a certified abstract of operating record from the department is required to comply with Iowa Code section 321.11 and the Driver's Privacy Protection Act.

This rule is intended to implement Iowa Code sections 321.11, 321.13 and 321A.3 and 18 U.S.C. §2721 et seq.

[ARC 6060C, IAB 12/1/21, effective 1/5/22]

[Filed ARC 6060C (Notice ARC 5921C, IAB 9/22/21), IAB 12/1/21, effective 1/5/22]



CHAPTERS 302 to 379  
Reserved



CHAPTER 380  
MOTOR VEHICLES OPERATED BY AN AUTOMATED DRIVING SYSTEM

**761—380.1(321) Applicability.** This chapter applies to driverless-capable motor vehicles operated by an automated driving system, which shall be regulated exclusively by the department under Iowa Code section 321.519.

This rule is intended to implement Iowa Code sections 321.514 through 321.519.

[ARC 5893C, IAB 9/8/21, effective 10/13/21]

**761—380.2(321) Definitions.** The definitions in Iowa Code section 321.514 are adopted and incorporated herein. In addition:

“*Conventional human driver*” means the same as defined in Iowa Code section 321.514 but does not include a driverless-capable vehicle user.

“*Driverless-capable vehicle*” as defined in Iowa Code section 321.514 means the vehicle meets one of the following classifications:

1. Level 3—conditional driving automation. The vehicle is capable of achieving the sustained and specific performance of the entire dynamic driving task as provided in the operational design domain. An SAE Level 3 vehicle requires a human operator to respond to a request to intervene issued by the automated driving system, as well as to dynamic driving task performance-relevant system failures in other vehicle systems. However, a driverless-capable Level 3 vehicle can be remotely operated without a human operator present in the vehicle.

2. Level 4—high driving automation. The vehicle is capable of achieving the sustained and specific performance of the entire dynamic driving task as provided in the operational design domain. An SAE Level 4 vehicle does not require a conventional human driver and does not require a driverless-capable vehicle user to be present in the vehicle or to perform remote operation to respond to a request to intervene issued by the automated driving system. A Level 4 vehicle is capable of fallback to a minimal risk condition without human intervention.

3. Level 5—full driving automation. The vehicle is capable of achieving the sustained and unconditional performance of the entire dynamic driving task. An SAE Level 5 vehicle is capable of performing all driving functions under all conditions. A Level 5 vehicle does not require a conventional human driver and does not require a driverless-capable vehicle user to be present in the vehicle or to perform remote operation to respond to a request to intervene issued by the automated driving system. A Level 5 vehicle is capable of fallback to a minimal risk condition without human intervention.

“*Driverless-capable vehicle user*” means a person who does not control the in-vehicle accelerating, braking, steering, and transmission gear selection input devices in order to operate a motor vehicle and who is not otherwise expected to respond to a request to intervene issued by the automated driving system of a driverless-capable vehicle.

“*Functional highway classifications*” means the process by which streets and highways are grouped into classes, or systems, according to the character of service the street or highway is intended to provide, and may include but not be limited to a functional highway classification established under 23 CFR Section 470.105.

“*Operational design domain*” means the same as defined in Iowa Code section 321.514.

“*Public highways*” means the same as “street” or “highway” as defined in Iowa Code section 321.1.

“*SAE*” means the Society of Automotive Engineers, which is an international association reputed for its standards development efforts, including its efforts to standardize definitions of driving automation systems.

This rule is intended to implement Iowa Code sections 321.1 and 321.514 and 23 CFR Section 470.105.

[ARC 5893C, IAB 9/8/21, effective 10/13/21]

**761—380.3(17A) Information and addresses.** Information and forms pertaining to driverless-capable vehicle exemptions and vehicle registration and operational restrictions issued by the department or a county treasurer for a driverless-capable vehicle may be obtained in the form and manner prescribed by the department by mail from the Motor Vehicle Division, Iowa Department of Transportation, P.O. Box 9278, Des Moines, Iowa 50306-9278; in person at 6310 SE Convenience Blvd., Ankeny, Iowa; by telephone at (515)237-3264; by email at [vscusto@iowadot.us](mailto:vscusto@iowadot.us); or on the department’s website at [www.iowadot.gov](http://www.iowadot.gov).

This rule is intended to implement Iowa Code section 17A.3.

[ARC 5893C, IAB 9/8/21, effective 10/13/21]

**761—380.4(321) Identification of driverless-capable vehicles in registration.** The SAE level of automation of a driverless-capable vehicle subject to registration under 761—Chapter 400 shall be listed in the department’s records system established under Iowa Code section 321.31 subject to possible changes to the SAE level of automation if the vehicle’s automated driving system is subsequently upgraded.

This rule is intended to implement Iowa Code sections 321.20, 321.31, 321.515 and 321.519.

[ARC 5893C, IAB 9/8/21, effective 10/13/21]

**761—380.5(321) Operational restrictions.** The department may impose operational restrictions on a driverless-capable vehicle as provided in rule 761—400.21(321) as a condition of registration of the vehicle. The manufacturer shall provide information to the department regarding the vehicle's operational design domain and associated operational restrictions. The manufacturer may subsequently provide information showing changes to the vehicle's operational design domain and associated operational restrictions if there are subsequent automated driving system design upgrades, and the department shall update its records accordingly.

This rule is intended to implement Iowa Code sections 321.515 and 321.519.

[ARC 5893C, IAB 9/8/21, effective 10/13/21]

**761—380.6(321) Identification of driverless-capable vehicle networks.** A person seeking to operate a for-hire driverless-capable vehicle network in Iowa, including an on-demand driverless-capable vehicle network, may be required to submit to the department the operational design domain as part of the application for the applicable permit under rule 761—524.3(325A) or 761—540.4(321N).

This rule is intended to implement Iowa Code sections 321.518 and 321.519.

[ARC 5893C, IAB 9/8/21, effective 10/13/21]

**761—380.7(17A,321) Driverless-capable vehicle exemption.**

**380.7(1) Application.** If a driverless-capable vehicle does not meet the standards set forth in Iowa Code section 321.515(1)“b,” a driverless-capable vehicle manufacturer or entity may apply in the form and manner prescribed by the department for an exemption to allow driverless operation of the vehicle. A manufacturer or entity seeking an exemption under this rule shall do all of the following:

*a.* Disclose in the application which traffic or motor vehicle safety law the driverless-capable vehicle is seeking an exemption from under Iowa Code section 321.515(1)“b.”

*b.* Submit information describing how the manufacturer or entity intends to operate under the exemption without posing a safety risk to the public.

**380.7(2) Issuance and display of exemption.** If all requirements of subrule 380.7(1) are met, and the department has sufficient information to determine a public safety risk does not exist, the department may issue the driverless-capable vehicle exemption. The exemption may include operational restrictions as provided under rule 761—400.21(321). The manufacturer or entity shall maintain a physical or electronic copy of the exemption and make it available for display at all times in the driverless-capable motor vehicle that is subject to the exemption. The copy may be in either a physical or an electronic format as prescribed by the department. The exemption shall be available for display or accessible to any peace officer upon request.

**380.7(3) Suspension or revocation and reinstatement.** The department may suspend or revoke a driverless-capable vehicle exemption if the exemption has been issued in conflict with the statutes or rules governing the exemption's issuance; if the exemption was issued based on false information; if there was a violation of Iowa Code sections 321.514 through 321.519, 761—Chapter 400 or this chapter; if the vehicle operating under the exemption is involved in a contributive motor vehicle accident attributable to the automated driving system performance in this or any other state and that accident results in death or serious injury; or if the vehicle is operated in violation of any of the motor vehicle laws of this or any other state that results in death or serious injury. For incidents occurring outside the state of Iowa, revocation may only occur once the investigation of the incident is completed and the vehicle's automated driving system performance was found to be involved in or contributive to a motor vehicle accident that resulted in a death or serious injury. The effective date of the suspension or revocation shall be 20 days after the department has mailed notice of the revocation to the manufacturer or entity by first class.

**380.7(4) Hearings.** A manufacturer or entity whose driverless-capable vehicle exemption has been suspended or revoked may contest the suspension or revocation in accordance with Iowa Code chapter 17A and 761—Chapter 13. The request for a hearing shall be submitted in writing to the director of the motor vehicle division. The request shall include, as applicable, the manufacturer's or entity's name, exemption number, complete address and telephone number. The request must be submitted within 20 days after the date of the notice of the suspension or revocation. The department shall stay the suspension or revocation of an exemption for the period that the manufacturer or entity is contesting the suspension or revocation under this rule.

This rule is intended to implement Iowa Code sections 321.381, 321.482, 321.515 and 321.519.

[ARC 5893C, IAB 9/8/21, effective 10/13/21]

[Filed ARC 5893C (Notice ARC 5621C, IAB 5/19/21), IAB 9/8/21, effective 10/13/21]

CHAPTERS 381 to 399  
Reserved



CHAPTER 400  
VEHICLE REGISTRATION AND CERTIFICATE OF TITLE  
[Prior to 6/3/87, Transportation Department[820]—(07,D)Ch 11]

**761—400.1(321,322,544) Definitions.** The definitions in Iowa Code section 321.1 are hereby made part of this chapter. In addition, the following words and phrases, when used in Iowa Code chapter 321 or this chapter, shall have the meanings respectively ascribed to them, except when the context otherwise requires.

“*Certificate of title*” means a document issued by the appropriate official which contains a statement of the owner’s title, the name and address of the owner, a description of the vehicle, a statement of all security interests and additional information required under the laws or rules of the jurisdiction in which the document was issued, and which is recognized as a matter of law as a document evidencing ownership of the vehicle described. The terms “title certificate,” “title only,” and “title” shall be synonymous with the term “Certificate of title.”

“*Contiguous county*” means any county in Iowa that directly borders an adjacent Iowa county, including sharing a common corner or corners.

“*Dealer’s or manufacturer’s stock or inventory*” means a vehicle owned by a dealer which is being held for sale or trade and for which the dealer has a duly assigned ownership document as required by Iowa Code section 321.45.

“*Driverless-capable vehicle*” means the same as defined in rule 761—380.2(321).

“*Electric vehicle annual registration fee*” means an annual registration fee for a battery electric or plug-in hybrid electric motor vehicle as provided in Iowa Code sections 321.116 and 321.117. Unless otherwise provided, for purposes of this chapter, any reference to a registration fee shall also include an annual registration fee for a battery electric or plug-in hybrid electric motor vehicle if that vehicle is a battery electric or plug-in hybrid electric motor vehicle as defined in Iowa Code sections 321.116 and 321.117.

“*Electronic*” means as defined in Iowa Code section 554D.103.

“*Electronic lien and title*” or “*ELT*” means an information technology system authorized by the department for the purpose of providing an electronic record of the certificate of title to a security interest holder in order to subject a vehicle to an electronic lien and to allow for the submission and receipt of forms related to security interests through electronic means as described in Iowa Code section 321.50.

“*Electronic record*” means as defined in Iowa Code section 554D.103.

“*Electronic signature*” means as defined in Iowa Code section 554D.103.

“*End user*” means a person or entity that directly uses the services of an electronic registration and titling (ERT) service provider to submit an electronic application for certificate of title or registration of a vehicle.

“*ERT service provider*” means a person or entity authorized by the department under subrule 400.3(17) to submit electronic applications for certificate of title or registration of a vehicle on behalf of an end user to a county treasurer.

“*Farm trailer*” means a trailer used exclusively by a farmer in the conduct of the farmer’s agricultural operation. The term shall not include a “semitrailer.”

“*Final-stage manufacturer*” means as defined in Iowa Code section 322.2.

“*Half-year fee*” means the first semiannual installment of an annual registration fee but does not include an electric vehicle annual registration fee. The term “half-year registration” shall be synonymous with the term “half-year fee.”

“*Hearse*” means a motor vehicle used exclusively to transport a deceased person.

“*Lien*” means an interest in a vehicle which secures payment or performance of an obligation. The term “security interest” shall be synonymous with the term “lien.”

“*Manufacturer’s certificate of origin*” means a certification signed by the manufacturer, distributor or importer that the vehicle described has been transferred to the person or dealer named and that the transfer is the first transfer of the vehicle in ordinary trade and commerce.

1. The terms “manufacturer’s statement,” “importer’s statement or certificate,” “MSO” and “MCO” shall be synonymous with the term “manufacturer’s certificate of origin.”

2. In addition to the requirements of Iowa Code subsection 321.45(1), the certificate shall contain a description of the vehicle which includes the make, model, style and vehicle identification number. The description of a motorized bicycle shall also specify the maximum speed.

3. For 1992 and subsequent model year vehicles, the form used for manufacturers’ certificates of origin shall be the universal form adopted in 1990 by the American Association of Motor Vehicle Administrators (AAMVA). This requirement does not apply to trailer-type vehicles. A copy of this universal form may be obtained from the motor vehicle division at the address in subrule 400.6(1).

“*Model year*,” except where otherwise specified, means the year of original manufacture or the year certified by the manufacturer. For purposes of titling and registration, the model year shall advance one year each January 1.

“*Registered*” means that the appropriate registration fee has been paid for a vehicle and a registration card evidencing payment has been issued to the owner.

“*Registration card*” means a document issued to the owner of a vehicle by the appropriate agency whose duty it is to register vehicles, which contains the name and address of the owner and a description of the vehicle, and which is issued to the owner when the vehicle has been registered. The terms “registration certificate,” “registration receipt” and “registration renewal receipt” are synonymous with the term “registration card.”

“*Security interest*” means an interest in a vehicle which secures payment or performance of an obligation. The term “lien” shall be synonymous with the term “security interest.”

“*Signature*,” unless otherwise specified, shall include a signature in ink or an electronic signature as provided in Iowa Code section 554D.103(9). A requirement to sign a document unless otherwise specified shall allow for a signature in ink or an electronic signature.

“*Social security number*” means a social security number issued by the United States government.

This rule is intended to implement Iowa Code chapter 554D and sections 321.1, 321.8, 321.20, 321.23, 321.24, 321.40, 321.45, 321.50, 321.116, 321.117, 321.123, 321.134, 321.157 and 322.2.

[ARC 9048B, IAB 9/8/10, effective 10/13/10; ARC 3449C, IAB 11/8/17, effective 12/13/17; ARC 3999C, IAB 9/12/18, effective 10/17/18; ARC 4343C, IAB 3/13/19, effective 4/17/19; ARC 4960C, IAB 3/11/20, effective 4/15/20; ARC 5178C, IAB 9/9/20, effective 10/14/20; ARC 5893C, IAB 9/8/21, effective 10/13/21; ARC 6287C, IAB 4/6/22, effective 5/11/22]

### **761—400.2(321,322) Vehicle registration, certificate of title, receipt, validation sticker and registration plates—general provisions.**

**400.2(1)** *Vehicles subject to registration.* A vehicle subject to registration under the laws of Iowa shall be required to be registered at the time the vehicle is first operated or moved upon a highway in this state.

**400.2(2)** *Vehicles exempt from titling or registration.* A certificate of title shall not be issued for a vehicle which is exempt from the titling or registration provisions of Iowa Code chapter 321, unless issuance of a certificate of title is specifically authorized in Iowa Code chapter 321 or as provided in 761—Chapter 410.

**400.2(3)** *Issuance of a certificate of title, receipt, validation sticker and registration plates upon payment of registration fees.* Except as otherwise provided in Iowa Code chapter 321 or this chapter, the current year registration fee and any delinquent registration fees and penalties, if any, shall be paid prior to issuance of a certificate of title, receipt, validation sticker and registration plates.

**400.2(4)** *Trailers with an empty weight of 2000 pounds or less.* Certificates of title shall not be issued for trailers with an empty weight of 2000 pounds or less. However, these trailers shall be subject to the registration fees provided in Iowa Code section 321.123.

**400.2(5)** *Vehicles owned by the government.* A certificate of title shall be issued for a vehicle owned by the government when the vehicle is first registered. However, vehicles owned by the government shall be exempted from registration and titling fees. Also, a certificate of title shall not be issued for a government-owned vehicle if a certificate of title would not be issued if the vehicle were owned by someone other than the government.

**400.2(6)** *Vehicles leased by the government.* Vehicles leased by the government for a period of 60 days or more are exempted from payment of registration fees. A copy of the lease agreement, certificate of lease, or other evidence that the vehicle is being leased by the government shall be required in order to obtain this exemption. However, the lessor is not exempted from the requirements for obtaining a certificate of title as set out in Iowa Code chapter 321 and these rules, including payment of the appropriate certificate of title fee.

**400.2(7)** *Special mobile equipment.* Rescinded IAB 3/7/90, effective 4/11/90.

**400.2(8)** *Private school buses, fire trucks, authorized emergency vehicles, and transit buses.* In accordance with Iowa Code sections 321.18, 321.19 and 321.22, private school buses, fire trucks not owned or operated for a pecuniary profit, certain authorized emergency vehicles owned and operated by nonprofit organizations, and urban and regional transit system buses are exempt from the payment of registration fees. However, these vehicles are not exempt from the requirements for obtaining a certificate of title as set out in Iowa Code chapter 321, including payment of the appropriate certificate of title fee.

**400.2(9)** *Towable recreational vehicles.* For purposes of registration and titling under Iowa Code chapter 321 and this chapter, a towable recreational vehicle as defined in Iowa Code section 322C.2 shall be considered a travel trailer or fifth-wheel travel trailer, as those terms are defined in Iowa Code section 321.1, as applicable.

**400.2(10)** *Plates for exempted vehicles.* Upon application, the department shall issue plates for exempted vehicles under subrules 400.2(5), 400.2(6) and 400.2(8) in accordance with the requirements in Iowa Code sections 321.18, 321.19, 321.22 and 321.170, as applicable, and this chapter. As authorized by Iowa Code sections 8A.361 and 8A.362(7), the Iowa department of administrative services may order the issuance of regular registration plates for

exempted vehicles assigned to the Iowa department of administrative services. The following process applies to regular registration plates issued to an exempted vehicle under Iowa Code section 321.19(1)“c”:

*a.* The requesting agency under Iowa Code section 321.19(1)“c,” other than the Iowa department of administrative services, shall file an application with the department in the form and manner prescribed by the department and shall certify the authorized purpose for which issuance of the registration plates for an exempted vehicle is requested.

*b.* The Iowa department of administrative services or the department may order the issuance of regular registration plates for exempted vehicles as authorized by Iowa Code section 321.19(1)“c.” The plates shall be assigned to a specific vehicle. The requesting agency shall notify the department within ten days of assigning the plate to another vehicle.

*c.* In accordance with Iowa Code section 321.19, the department shall maintain separate records of regular registration plates issued to exempted vehicles, which shall be available in a manner that allows law enforcement and other persons authorized by Iowa Code section 321.11(3) to query vehicle and owner information by the registration plate number.

*d.* If a vehicle to which regular registration plates are assigned under this subrule is no longer used for an exempted purpose, the requesting agency shall surrender the plates to the department and the department shall cancel the plates. The department may revoke the plates and require the agency to surrender the plates pursuant to Iowa Code section 321.103 if the department determines use of the plates is no longer authorized.

This rule is intended to implement Iowa Code sections 321.18 through 321.22, 321.24, 321.34, 321.103, 321.123, 321.170 and 322C.2(19).

[ARC 4960C, IAB 3/11/20, effective 4/15/20; ARC 6287C, IAB 4/6/22, effective 5/11/22]

#### **761—400.3(321) Application for certificate of title or registration for a vehicle.**

**400.3(1)** *Application form.* To apply for a certificate of title or registration for a vehicle, the owner of the vehicle shall complete an application form prescribed by the department, which may be electronic. Application shall be made in accordance with Iowa Code chapter 321, these rules, and other applicable provisions of law.

**400.3(2)** *Full legal name.* Full legal names shall be given on the application. Civilian or military titles and nicknames shall not be used.

**400.3(3)** *Information about owner, lessee and primary user.*

*a.* Iowa Code sections 321.20 and 321.109 list the information that must be disclosed by the owner, lessee and primary user on the application.

*b.* A firm, association, corporation, or trust that is not required to have a federal employer identification number shall disclose the social security number, Iowa driver’s license number or Iowa nonoperator’s identification card number of an authorized representative of the firm, association, corporation, or trust. The authorized representative of a trust is the trustee unless otherwise specified in the trust agreement or the certification of trust as defined in Iowa Code section 633A.4604.

**400.3(4)** *Plate number and validation number.* If the owner has registration plates that have been assigned to the owner and affixed to the vehicle, the owner shall list the plate number on the application form. The validation number from the validation sticker shall also be listed.

**400.3(5)** *Birth or registration month.* If the vehicle is owned by one individual, the individual’s month of birth shall be listed on the application form and shall determine the registration year. If the vehicle is owned by two or three individuals, the month of birth of one of the individuals shall be listed and shall determine the registration year. If the vehicle is owned by a partnership, corporation, association, or governmental subdivision, the birth or registration month shall be left blank on the application; the county treasurer shall determine the month of registration.

**400.3(6)** *Model year.* The application shall include the model year of the vehicle.

**400.3(7)** *Purchase information.* The application shall include the date of purchase or acquisition and, if the vehicle was not purchased from a dealer, the purchase price.

**400.3(8)** *Vehicle color.* The application shall include the vehicle color.

**400.3(9)** *Foreign registered vehicle.* If the vehicle is registered in a foreign jurisdiction, the application shall include the date the vehicle was brought into Iowa.

**400.3(10)** *Signature of applicant.* The owner shall sign the application form. If there are two or more owners, all owner signatures are necessary.

**400.3(11)** *Dealer certification.*

*a.* If the vehicle is a new vehicle which has been sold to the owner by a dealer, as defined in Iowa Code section 321.1, the dealer shall certify the following on the application form: sale price of the vehicle, the amounts allowed for

property traded in, nontaxable charges and rebates, the tax price of the vehicle, the date that a “Registration Applied For” card was issued, and the registration fee collected.

b. The certification shall include the dealer’s number and name and shall be signed by the dealer or an authorized representative of the dealer. The signature may be electronic when the application form is submitted electronically in a manner approved by the department.

**400.3(12) Weigh ticket.** If application is being made to lower the tonnage on any motor truck, bus or truck tractor, the county treasurer may require a copy of a stamped weigh ticket issued by any public scale.

**400.3(13) Credits.** See rule 761—400.60(321) for:

Credit for unexpired registration fee.

Credit for transfer to spouse, parent or child.

Credit from/to apportioned registration.

Assignment of credit and registration plates from lessor to lessee.

**400.3(14) Leased vehicle.** As required by Iowa Code section 423.26, the lessor shall list the lease price of the vehicle and the lessor’s leasing number, if applicable, on the application form.

**400.3(15) Affidavit of correction.** As provided in Iowa Code section 321.23A, the county treasurer or the department may accept an affidavit of correction on a form prescribed by the department.

a. The affidavit may be used only to correct those errors, erasures or alterations listed on the affidavit.

b. The affidavit must contain the signatures of all parties to the original error, erasure or alteration.

c. Only an original, notarized affidavit shall be accepted.

d. The affidavit must be surrendered with the document that contains the error, erasure or alteration to be corrected.

e. The affidavit may be accepted to correct errors, erasures or alterations on either an Iowa title or a foreign title.

**400.3(16) Driverless-capable vehicle.** As provided in Iowa Code sections 321.20 and 321.515 and rule 761—400.21(321), the applicant shall indicate on the application whether the vehicle is a driverless-capable vehicle as defined in rule 761—380.2(321).

**400.3(17) Electronic applications.**

a. Applications for certificate of title or registration of a vehicle may be submitted electronically via web-based services offered and maintained by ERT service providers authorized by the department. To be authorized to serve as an ERT service provider, the ERT service provider must establish to the satisfaction of the department that the ERT service provider has the technical, financial, legal, and administrative capacity to meet the department’s requirements for submission of electronic applications and must execute an agreement, in a form and content determined by the department, that authorizes and permits the ERT service provider to interact with the department’s vehicle title and registration system via an application program interface established by the department and to submit electronic applications on behalf of end users that choose to use the ERT service provider’s services to submit an application electronically. Agreements executed by ERT service providers under this paragraph shall include provisions that address security, financial responsibility, privacy, termination, and any other matters deemed appropriate by the department.

b. An agreement executed by an ERT service provider is a condition of authorization and permission only. An ERT service provider authorized by the department is not a contractor, vendor, employee, or agent for the department, the state of Iowa, or any county treasurer accepting electronic applications, and shall not be entitled to compensation from the department, the state of Iowa, or any county treasurer for any service, transaction, or other act rendered as an ERT service provider. The ERT service provider remains solely liable and responsible for the ERT service provider’s services and activities as an ERT service provider and shall defend, indemnify and hold harmless the department, any county treasurer, the state of Iowa, and its, or their agents, officers, heirs, assigns, and employees of and from any and all damages, claims, penalties, debts owed, or any other form of liability arising from or related to the ERT service provider’s service, performance, errors, acts, or omissions. An ERT service provider that chooses to provide service under the department’s permission and authorization does so at the ERT service provider’s sole risk and has no claim or right against the department, any county treasurer, or the state of Iowa for fees, costs, profits, loss of profits, interruption of business, or any other form of compensation, remuneration, liability, or damages arising from or related to the ERT service provider’s activity as an ERT service provider or inability to serve as an ERT service provider.

c. An ERT service provider authorized by the department may establish web-based services to allow end users to submit applications via an electronic interface established and maintained by the ERT service provider and to submit the applications on behalf of the end user to county treasurers via the department’s vehicle title and registration system and application program interface established by the department. In doing so, the ERT service provider is acting as a contractor or vendor for the end user and not the department, any county treasurer, or the state of Iowa, and remains solely responsible to the end user for any failure to perform or breach of performance or agreement. When the

end user is a motor vehicle dealer licensed by the department under Iowa Code chapter 322 or 322C, “end user” includes the motor vehicle dealer and any person with an interest in the vehicle that is the subject of the application. The ERT service provider may charge the end user a fee for services rendered as an ERT service provider.

*d.* In addition to the documentary fee authorized under Iowa Code section 322.19A, an end user that is a motor vehicle dealer licensed by the department under Iowa Code chapter 322 or 322C may pass and charge to a customer the fees or costs incurred by the motor vehicle dealer to submit the customer’s application through an ERT service provider’s services as a third-party cost or fee, provided that the motor vehicle dealer discloses the charge to the customer before submitting the application. The documentary fee charged by the motor vehicle dealer shall not exceed the amount authorized by Iowa Code section 322.19A. Neither the ERT service provider nor the motor vehicle dealer shall charge a customer for creation or delivery of a “registration applied for” card.

*e.* An ERT service provider authorized by the department has no authority to approve or deny applications. Acceptance of an application by an ERT service provider is not approval of the application. An application is not considered to be formally submitted until it is electronically transmitted by the ERT service provider to the county treasurer via the department’s vehicle title and registration system and the application program interface established by the department. The county treasurer remains responsible for approving or denying the application and may reject the application for any reason permitted or required by state or federal law or regulation.

*f.* An authorized ERT service provider is responsible for the ERT service provider’s payment solution and for all payment transaction security and compliance with all applicable standards associated with the payment solution or solutions offered by the ERT service provider. The ERT service provider shall transfer title and registration fees collected by the ERT service provider directly to an account designated by the county treasurer responsible for the transaction via automated clearing house (ACH) transfer and the fees shall be available to the county treasurer no later than three business days following the submission of a transaction for which the fees were paid. Funds received by the ERT service provider shall be held until transfer to the county treasurer’s account in a bank insured by the Federal Deposit Insurance Corporation. The ERT service provider shall be responsible for reconciling insufficient funds from an end user.

*g.* Fees submitted electronically are not deemed to be received until deposited into the county treasurer’s account via completion of the ACH transfer. The end user remains responsible for fees submitted via an ERT service provider and the end user’s responsibility for payment of any required fees is not waived or excused by the ERT service provider’s failure to complete the transfer. As a condition of authorization and permission to serve as an ERT service provider and before the ERT service provider may offer services, the ERT service provider shall furnish a surety bond executed by the ERT service provider as principal and executed by a corporate surety company, licensed and qualified to do business within the state of Iowa. The bond shall run to the state of Iowa, be in the amount of \$150,000 and be conditioned upon the faithful compliance by the ERT service provider of all obligations imposed upon the ERT service provider by any applicable state or federal law or regulation, including the terms of this chapter, the authorizing agreement executed by the ERT service provider under this chapter, and any terms or conditions existing between the ERT service provider and any end user using the ERT service provider’s services. The ERT service provider shall indemnify any end user that uses the ERT service provider’s services of and from any loss or damage occasioned by the failure of the ERT service provider to so comply, including but not limited to the complete and timely submission to the county treasurer of the title and registration fees required for a given transaction. The bond shall be filed with the department before the ERT service provider may begin or offer services as an ERT service provider. The aggregate liability of the surety shall not exceed the amount of the bond.

*h.* The ERT service provider shall provide accounting reports of all fees received and transferred to each respective county treasurer, in a manner determined by the department.

*i.* The ERT service provider shall submit to audits by the department and the state auditor, which shall be at least yearly but may be more frequently if determined necessary by the department or the state auditor.

*j.* An application submitted electronically must meet all legal requirements for the transaction in question, and no requirement shall be excused or waived as a result of submitting the transaction electronically. However, wherever a signature is required, the signature may be an electronic signature, as determined by the department and according to methods approved by the department. Wherever an electronic solution approved by the department requires the submission of scanned documents, the scanned documents shall be of a quality and resolution determined by the department, which shall at a minimum meet any applicable state or federal standard or requirement, and shall completely capture and represent the original document. The department and any county treasurer processing an application retain the right under Iowa Code section 321.13 to determine the genuineness, regularity, and legality of the application and any scanned document submitted as part of the application and may withhold approval of the application and require presentation of the original document whenever the scanned document is of insufficient quality, content, or appearance to determine the same. An end user that submits a scan of an original document as part

of an electronic application shall retain the original document for a period of six months. An end user shall make all such original documents available for inspection by the department at the department's request. An end user that is a business entity shall retain the documents at the end user's principal place of business in Iowa. Anything in this paragraph notwithstanding, lessors required to retain a damage disclosure statement under Iowa Code section 321.69(4), and authorized vehicle recyclers licensed under Iowa Code chapter 321H and motor vehicle dealers licensed under Iowa Code chapter 322 required to retain damage disclosure statements under Iowa Code section 321.69(6) shall retain the original document for a period of five years from the date of the statement, as required therein.

*k.* An end user that is a motor vehicle dealer licensed by the department under Iowa Code chapter 322 or 322C and that electronically submits an application on behalf of the owner or owners to whom the dealer is transferring or delivering the vehicle shall disclose to all owners or, if there is more than one owner and the title application uses "or" between the names of the owners, at least one owner, that the application will be submitted electronically and shall obtain written authorization from all owners, or if there is more than one owner and the title application uses "or" between the names of the owners, written authorization from at least one owner, to submit the application on the owner's behalf. The written authorization shall be retained at the motor vehicle dealer's principal place of business for a period of six months from the date of application and shall be available for inspection by the department at the department's request. The motor vehicle dealer shall also review with and disclose to the owner or owners all details of the application, before submitting the application, and shall provide a complete, true, and accurate copy of the application to the owner or owners immediately after submitting the application. The written authorization shall be submitted in the form and manner required by the department.

*l.* An authorized ERT service provider shall retain all data, information, records, and electronic records associated with an electronic application or transaction submitted or transacted through the ERT service provider for a period of at least six months, or longer as required by applicable state or federal law or regulation, and shall make all such data, information, and records available to the department at the department's request. This includes but is not limited to the identity of the end user that initiated the electronic application or transaction. Identity information for end users shall be maintained at the entity and individual level, meaning that the ERT service provider must implement and maintain secure profile management that is capable of authenticating and verifying the identity of any entity that initiated the application or transaction and the individual officer, employee, or agent within the entity that was authorized by the entity to initiate the application or transaction.

*m.* The ERT service provider shall hold and protect all personal information as required by Iowa Code section 321.11 and the federal Driver's Privacy Protection Act, 18 U.S.C. §2721 et seq. (the DPPA), shall only use or release such personal information for purposes necessary to perform services as an ERT service provider, and shall release such personal information for no other purposes or use except as required to comply with legal or administrative matters as permitted under the DPPA. The ERT service provider shall immediately advise the department of any suspected or actual unauthorized release of personal information or highly restricted personal information and shall notify the entity and individual whose personal information or highly restricted personal information was released in an unauthorized manner.

This rule is intended to implement Iowa Code sections 321.1, 321.8, 321.20, 321.23 to 321.26, 321.31, 321.34, 321.46, 321.105A, 321.109, 321.122, 321.515, 321.519, 322.19A and 423.26.

[ARC 9048B, IAB 9/8/10, effective 10/13/10; ARC 3449C, IAB 11/8/17, effective 12/13/17; ARC 3999C, IAB 9/12/18, effective 10/17/18; ARC 5893C, IAB 9/8/21, effective 10/13/21; ARC 6219C, IAB 3/9/22, effective 4/13/22; ARC 6287C, IAB 4/6/22, effective 5/11/22]

**761—400.4(321) Supporting documents required.** This rule describes the basic supporting documents to be submitted by an applicant for a certificate of title or registration.

**400.4(1) New vehicle.** If application is made for a new vehicle, a manufacturer's certificate of origin, properly assigned to the applicant, shall be submitted. A manufacturer's certificate of origin shall not be accepted if the assignment to the applicant is made by any person other than the manufacturer, importer or distributor, a licensed motor vehicle dealer franchised to sell that line-make of vehicle, or a final-stage manufacturer motor vehicle dealer licensed under rule 761—425.11(322).

*a.* The first person, including a dealer not franchised to sell that line-make of vehicle, who is assigned the manufacturer's certificate of origin shall obtain a certificate of title and register the vehicle.

*b.* An uncanceled security interest noted on the reverse side of a manufacturer's certificate of origin (MCO) shall be noted as a separate security interest on the certificate of title, in addition to any security interest acknowledged by the applicant, unless the security interest acknowledged by the applicant is the same as the one noted on the reverse side of the MCO.

c. If a 1980 or subsequent model year vehicle is manufactured by a person other than the original manufacturer, both the original manufacturer's certificate of origin and the final-stage manufacturer's certificate of origin shall be submitted if the vehicle's original line-make is changed by the final-stage manufacturer. All assignments or reassignments of ownership of the vehicle shall be made on the final-stage manufacturer's certificate of origin. The face of the original manufacturer's certificate of origin shall be stamped in bold type with the statement: "Final-stage manufacturer's MCO has been issued on this vehicle." The original manufacturer's vehicle identification number shall be listed on the final-stage manufacturer's certificate of origin.

d. If a final-stage manufacturer is a motor vehicle dealer licensed under rule 761—425.11(322), the final-stage manufacturer may reassign the original manufacturer's certificate of origin or an incomplete or intermediate MCO to the retail buyer.

**400.4(2)** *Used vehicle registered or titled in this state.* The last issued certificate of title, properly assigned to the applicant, shall be submitted, unless the applicant is an insurer applying for a salvage certificate of title under Iowa Code section 321.52(4). An uncanceled security interest noted on the face of the certificate of title shall be noted on the face of the certificate of title issued to the applicant, in addition to any security interest acknowledged by the applicant. If the vehicle is not subject to titling provisions, the last issued registration receipt or bill of sale, properly assigned to the applicant, shall be submitted.

**400.4(3)** *Used vehicle from a foreign jurisdiction.* If the vehicle was subject to the issuance of a certificate of title in the foreign jurisdiction, the certificate of title issued by the foreign jurisdiction to the applicant or properly assigned to the applicant shall be submitted, unless the applicant is an insurer applying for a salvage certificate of title under Iowa Code section 321.52(4).

a. A security interest, noted on the face of the foreign certificate of title, which has not been canceled, shall be noted on the face of the certificate of title issued to the applicant, in addition to any security interest acknowledged by the applicant.

b. A certificate of title issued in a foreign jurisdiction may be assigned to a motor vehicle dealer in another jurisdiction, and the dealer may reassign the certificate of title to the applicant. An assignment or reassignment form issued by a foreign jurisdiction may be used with a foreign title to complete an assignment or reassignment of ownership from a foreign motor vehicle dealer to the applicant, provided the ownership chain is complete.

c. An Iowa licensed motor vehicle dealer who acquires a vehicle registered in another state or country may reassign the foreign certificate of title to the applicant, as provided in Iowa Code subsection 321.48(2) and rule 761—400.27(321,322).

d. A person who registers a foreign vehicle under Iowa Code section 321.23(3) shall be issued a nontransferable-nonnegotiable registration. To transfer ownership of the vehicle, the owner must first obtain an Iowa certificate of title except as follows: If ownership is transferred to an Iowa licensed motor vehicle dealer or an insurance carrier authorized to do business in Iowa as provided in Iowa Code section 321.23(3), the foreign certificate of title may be assigned to the dealer or the insurance carrier; the owner is not required to obtain an Iowa title. The dealer may then reassign the foreign title, as provided in Iowa Code section 321.48(2) and rule 761—400.27(321,322).

e. If the vehicle was not subject to the issuance of a certificate of title in the foreign jurisdiction, the registration document issued by the foreign jurisdiction to the applicant or properly assigned to the applicant shall be submitted.

(1) If the foreign registration document is not issued in the applicant's name and does not contain an assignment of ownership form, a bill of sale conveying ownership from the owner as listed on the foreign registration document to the applicant shall be submitted with the foreign registration document.

(2) Upon receipt of the foreign registration document, the county treasurer shall issue a nontransferable—nonnegotiable registration unless the foreign registration document has been approved by the department.

(3) Acceptance of the foreign registration document shall be determined by the department on an individual basis, if the county treasurer of the county where the certificate of title is to be issued cannot determine whether the document is acceptable.

f. If a trailer weighing 2000 lbs. or less is exempt from the issuance of a certificate of title and registration in the foreign jurisdiction, a bill of sale conveying ownership to the applicant, if acquired by a resident from a nonresident, or an affidavit of ownership signed by the applicant, if the applicant is establishing residence in this state, shall be submitted.

g. If a motor vehicle is exempt from the issuance of a certificate of title and registration in the foreign jurisdiction, the bonding procedures as provided in Iowa Code section 321.24 shall be followed.

**400.4(4)** *Used vehicle acquired by a resident of this state from a government agency.* If the vehicle was acquired from an agency of the federal government, the applicant shall surrender the government bill of sale, General Services Administration Form 97, or Internal Revenue Service Form 2435, properly assigned to the applicant. If the vehicle

was acquired from the state of Iowa or a subdivision of government, the applicant shall surrender the Iowa certificate of title issued in the name of the agency, properly assigned to the applicant.

**400.4(5)** *Manufactured or mobile home.* If the vehicle described on the application is a manufactured or mobile home with an Iowa title, the applicant shall submit a tax clearance form to show that no taxes are owing, unless the title has been issued to a manufactured or mobile home retailer licensed under Iowa Code chapter 103A. The form may be obtained by any owner of record of the manufactured or mobile home from the county treasurer.

**400.4(6)** *Vehicle acquired by a resident of this state by operation of law.* If the vehicle was acquired by the applicant by operation of law as specified in Iowa Code section 321.47, the last issued certificate of title shall be submitted by the applicant, or when that is not possible, presentation of satisfactory proof of the applicant's ownership and right of possession to the vehicle shall be submitted by the applicant. Proof of ownership may consist of a foreclosure sale affidavit, artisan's or storage lien affidavit, affidavit of death intestate, abandoned vehicle sales receipt, peace officers bill of sale or court order. See also subrules 400.14(4) and 400.14(5).

**400.4(7)** *Foreign ownership document issued in a language other than English.* A foreign ownership document issued in a language other than English may be required to be reproduced in writing in English and certified to be a correct translation by a person qualified to translate that particular language. The English translation and certification shall be submitted with the foreign ownership document.

**400.4(8)** *Titles from foreign jurisdictions.*

*a.* Except as provided in paragraph "b" of this subrule, a certificate of title issued by a foreign jurisdiction shall not be accepted if the title contains an alteration or erasure.

*b.* An affidavit of correction form issued by a foreign jurisdiction that corrects the certificate of title issued by the foreign jurisdiction shall be accepted only for the reason listed on the affidavit of correction form. However, acceptance of an affidavit of correction form that corrects an odometer statement or a designation shall be determined by the department on an individual basis.

**400.4(9)** *Applications in the name of trusts.* An application in the name of a trust shall be accompanied by a copy of all documents creating or otherwise affecting the trust or by the certification of trust as defined in Iowa Code section 633A.4604.

*a.* The certification of trust may be signed by any trustee or the attorney for any trustee.

*b.* The application shall be signed by the number of trustees as specified in the trust agreement, and the applicant shall provide the department with the document or the certification of trust specifying the required signatories for the trust.

*c.* If a certification of trust is provided, one of the following shall apply:

(1) Any currently acting trustee may sign the application if the certification of trust states that such trustee may act individually.

(2) A majority of the trustees must sign the application if the certification of trust states that the trustees must act by majority decision.

(3) All currently acting trustees must sign the application if the certification of trust states that the trustees must act by unanimous decision.

*d.* A certification of trust must meet the requirements of Iowa Code section 633A.4604, including but not limited to providing the names of all the currently acting trustees. If there are two or more currently acting trustees, the certification of trust must state whether the trustees may act individually, whether the trustees must act by majority decision or whether the trustees must act by unanimous decision. If the certification of trust does not meet said requirements, the certification of trust will be considered invalid for the purposes of the application.

*e.* Each signature on the application shall be followed by the words "as trustee."

**400.4(10)** *Driverless-capable vehicles.* If an application is made for a driverless-capable vehicle, the department may require the application to be accompanied by the operational design domain.

**400.4(11)** *Supporting document retained by county treasurer.* All supporting documents, except those submitted pursuant to subrule 400.3(17), shall be retained by the county treasurer.

This rule is intended to implement Iowa Code sections 321.20, 321.23, 321.24, 321.30, 321.31, 321.45 to 321.50, 321.67, 321.515, 321.519, 322.3 and 633A.4604.

[ARC 9048B, IAB 9/8/10, effective 10/13/10; ARC 3449C, IAB 11/8/17, effective 12/13/17; ARC 3999C, IAB 9/12/18, effective 10/17/18; ARC 4343C, IAB 3/13/19, effective 4/17/19; ARC 4960C, IAB 3/11/20, effective 4/15/20; ARC 5893C, IAB 9/8/21, effective 10/13/21; ARC 6219C, IAB 3/9/22, effective 4/13/22; ARC 6287C, IAB 4/6/22, effective 5/11/22; ARC 6932C, IAB 3/8/23, effective 4/12/23]

#### **761—400.5(321) Where to apply for registration or certificate of title.**

**400.5(1)** Except as otherwise provided, application for the registration of a vehicle or a certificate of title for a vehicle, or transfers thereof, shall be made to the county treasurer as described in Iowa Code chapter 321, including,

when applicable, the county treasurer of a contiguous county to the county designated for the owner under Iowa Code section 321.20(1) for registration and issuance of a certificate of title. When none of the primary users of a non-resident-owned vehicle are located in Iowa, the vehicle may be registered by the county treasurer of any county.

**400.5(2)** Application shall be made to the department's motor vehicle division for the following:

- a. Titling and registration of vehicles owned by the government. This requirement does not apply to manufactured or mobile homes subject to a public bidder sale as explained in Iowa Code subsection 321.46(2).
- b. Registration of vehicles leased by the government for a period of 60 days or more.
- c. Registration of urban and regional transit system buses.
- d. Registration of fire trucks not owned and operated for a pecuniary profit.
- e. Registration of certain authorized emergency vehicles owned and operated by nonprofit organizations.
- f. Registration of private school buses.
- g. Registration of vehicles under the provisions of Iowa Code subsection 321.23(4), relating to restricted-use vehicles.

**400.5(3)** Application for a certificate of title for a vehicle subject to apportioned registration under Iowa Code chapter 326 may be made to either the county treasurer or to the department's motor vehicle division.

**400.5(4)** Application for apportioned registration shall be made to the department's motor vehicle division. See 761—Chapter 500.

This rule is intended to implement Iowa Code sections 321.18 through 321.23, 321.46(2), and 321.170.

[ARC 3999C, IAB 9/12/18, effective 10/17/18; ARC 4960C, IAB 3/11/20, effective 4/15/20; ARC 6287C, IAB 4/6/22, effective 5/11/22]

**761—400.6(17A) Addresses, information and forms.** Assistance under this chapter is available as follows:

**400.6(1)** Information and forms for vehicle registration, certificate of title, or other procedures covered under Iowa Code sections 321.18 through 321.173 may be obtained from the county treasurer or by mail from the Motor Vehicle Division, Iowa Department of Transportation, P.O. Box 9278, Des Moines, Iowa 50306-9278; in person at Iowa Department of Transportation, 6310 SE Convenience Blvd., Ankeny, Iowa 50021; by telephone at (515)237-3110; or on the department's website at [www.iowadot.gov](http://www.iowadot.gov).

**400.6(2)** Information for investigations under this chapter may be obtained from the Bureau of Investigation and Identity Protection, Iowa Department of Transportation, 6310 SE Convenience Blvd., Ankeny, Iowa 50021; by telephone at (515)237-3050; or on the department's website at [www.iowadot.gov](http://www.iowadot.gov).

This rule is intended to implement Iowa Code section 17A.3.

[ARC 9048B, IAB 9/8/10, effective 10/13/10; ARC 3999C, IAB 9/12/18, effective 10/17/18; ARC 4960C, IAB 3/11/20, effective 4/15/20; ARC 6287C, IAB 4/6/22, effective 5/11/22]

**761—400.7(321) Information appearing on title or registration.** In addition to the requirements of Iowa Code sections 321.24, 321.52, 321.69, 321.71 and 322G.12, a certificate of title or registration receipt or both shall contain the following information when applicable:

**400.7(1)** Registration expiration date.

**400.7(2)** Registration month, as explained in rule 761—400.3(321).

**400.7(3)** Name and address of last titled owner.

**400.7(4)** Description of the vehicle, including the following items. These items may be represented on the title and registration by code letters or numbers.

a. Vehicle identification number.

b. Type, such as automobile, trailer, truck, etc.

c. Style.

d. Make, model, and model year.

e. Number of engine cylinders.

f. Color.

g. Weight and registered gross weight.

h. The square footage of floor space of a manufactured or mobile home or travel trailer, as determined by measuring the exterior.

i. The odometer mileage and whether the mileage is "actual," "not actual," or "exceeds mechanical limits."

**400.7(5)** Previous Iowa title number or the name of the foreign jurisdiction if the previous title is a foreign title.

**400.7(6)** Plate number and previous registration number.

**400.7(7)** List price or value.

**400.7(8)** Penalties and title, registration and security interest receipt numbers.

**400.7(9)** The following phrase stamped on the reassignment portion of a manufactured or mobile home title: “Dealer reassignment not authorized on this certificate of title.”

**400.7(10)** The designation required by 761—Chapter 405. A vehicle may have no more than one designation. The referenced rules explain which designation takes precedence when more than one designation could apply.

**400.7(11)** Full legal name of owner.

*a.* When the name of an owner changes from that which is printed on the title or registration issued to the owner, the owner shall submit to the county treasurer one of the following documents:

- (1) Court order for a name change. The court order must contain the full name, date of birth, and court seal.
- (2) Divorce decree.
- (3) Marriage certificate.

*b.* This subrule does not apply to owners that are firms, associations, corporations, or trusts.

*c.* When the name of an owner changes from that which is printed on the registration card, the owner shall apply for a replacement registration card.

**400.7(12)** Driverless-capable vehicle indicator, which may also indicate whether operational restrictions exist.

This rule is intended to implement Iowa Code sections 321.24, 321.31, 321.40, 321.45, 321.52, 321.69, 321.71, 321.124, 321.515, 321.519 and 322G.12.

[ARC 0136C, IAB 5/30/12, effective 7/4/12; ARC 3999C, IAB 9/12/18, effective 10/17/18; ARC 5893C, IAB 9/8/21, effective 10/13/21]

### **761—400.8(321) Release form for cancellation of security interest.**

**400.8(1)** A secured party may use a form prescribed by the department to note the cancellation of a security interest.

**400.8(2)** The secured party may also note the cancellation in a statement written on the secured party’s letterhead if the statement is notarized and contains the following information: county that issued the title; title number; security interest number; vehicle identification number; vehicle owner’s name; secured party’s name, street address, city, state and ZIP code; date the security interest was canceled; and signature of an authorized representative of the secured party.

**400.8(3)** The secured party shall forward the original cancellation form or statement to the department or to the county treasurer of the county where the title was issued. Facsimiles and photocopies are not acceptable.

**400.8(4)** The secured party shall note the cancellation on the face of the title, attach a copy of the release form to the title as evidence of cancellation, and forward the title to the next secured party or, if there is no other secured party, to the person designated by the owner or, if there is no person designated, to the owner.

This rule is intended to implement Iowa Code section 321.50.

[ARC 4343C, IAB 3/13/19, effective 4/17/19]

### **761—400.9(321) Security interest notation, 30-day limit.** Rescinded IAB 11/23/05, effective 12/28/05.

**761—400.10(321) Assignment of security interest.** A security interest noted on a certificate of title may be assigned to another secured party without losing the seniority of the security interest by complying with the procedure in Iowa Code section 321.50 or with the following procedure:

**400.10(1)** *Notice of assignment.* The secured party listed on the title certificate shall make the following notation in the cancellation portion of the certificate of title where security interest is noted “Assigned to (name of assignee).” The date, name of secured party and signature of the person noting the assignment shall be completed in the cancellation portion pertaining to the security interest.

**400.10(2)** *Application for notation of security interest.* The assignee shall complete an application for notation of a security interest on the form provided by the department. The application form shall be signed by the assignee in the space where the signature of the owner is ordinarily required. The signature of the owner shall not be required on an assignment of a security interest.

**400.10(3)** *Submission of documents to county treasurer.* The certificate of title, application for notation of security interest and appropriate notation fee shall be submitted to the county treasurer of the county where the certificate of title was issued or will be issued.

*a.* If there are additional security interests noted on the certificate of title, the seniority of the assignee’s security interest may be preserved by issuance of a certificate of title in lieu of the original, on which the assignee’s security interest shall be noted in the same seniority as the assignor’s.

*b.* A receipt for notation of security interest form shall be processed and the new receipt number shall be listed in the appropriate space provided. The original notation date shall also be listed and the words “by assignment” shall be listed following the name of the assignee.

This rule is intended to implement Iowa Code section 321.50.

**761—400.11(321) Sheriff's levy, restitution lien, and forfeiture lien noted as security interests.**

**400.11(1)** A sheriff's levy may be noted as a security interest on a certificate of title if the sheriff so desires. To apply for a notation of a security interest, the sheriff or the sheriff's deputy shall complete an application form prescribed by the department. The sheriff or sheriff's deputy shall sign the application in the space where the signature of the owner is ordinarily required. The signature of the owner is not required. The appropriate notation fee shall be submitted with the application form to the county treasurer of the county where the certificate of title was issued. If the certificate of title is not surrendered with the application, the county treasurer shall notify the holder of the certificate of title in the manner prescribed in Iowa Code section 321.50.

**400.11(2)** A restitution or forfeiture lien may be noted as a security interest on a certificate of title if the county attorney so desires. To apply for a notation of a security interest, the county attorney or designee shall complete an application form prescribed by the department. The county attorney or designee shall sign the application in the space where the signature of the owner is ordinarily required. The signature of the owner is not required. A lien notation fee is not required. If the certificate of title is not surrendered with the application, the county treasurer shall notify the holder of the certificate of title in the manner prescribed in Iowa Code section 321.50.

This rule is intended to implement Iowa Code section 321.50 and chapter 809A.

[ARC 9048B, IAB 9/8/10, effective 10/13/10]

**761—400.12(321) Replacement certificate of title.**

**400.12(1)** When a certificate of title is lost, destroyed or altered, the owner or lienholder shall apply for a replacement certificate of title. If a security interest noted on the certificate of title was released by the secured party on a separate form, but the secured party has not delivered the original certificate of title to the appropriate party, the owner may apply for a replacement certificate of title as provided in Iowa Code section 321.42.

**400.12(2)** Application for a replacement certificate of title shall be made on a form prescribed by the department. All owners of the vehicle as listed on the certificate of title shall sign the application form. If an owner is deceased, the signatures and documents specified in subrules 400.14(4) and 400.14(5) shall be required in lieu of the deceased owner's signature. A person entitled to vehicle ownership under the laws of descent and distribution shall sign the required forms and shall insert the words "heir at law" following the signature.

This rule is intended to implement Iowa Code section 321.42.

**761—400.13(321) Bond required before title issued.** An applicant for a certificate of title who cannot provide the supporting documents required in rule 761—400.4(321) shall be required to file a bond as a condition to obtaining a title and registration plates.

**400.13(1) Procedures.** This subrule describes the procedures to be followed to obtain a "bonded" certificate of title. The procedures described are in addition to the regular procedures for titling and registering a vehicle.

*a.* The applicant shall submit a bond application to the motor vehicle division on a form prescribed by the department. The application shall be accompanied by evidence of ownership of the vehicle.

*b.* The department shall search the state files to determine if there is an owner of record or security interest for the vehicle and if the vehicle has been reported stolen or embezzled.

(1) If an owner of record is found, the department shall mail a release letter by first-class mail to the owner of record at the owner's last-known address. The release letter shall notify the owner of the right to claim ownership of the vehicle or to waive all rights or claims.

(2) If the owner of record makes a claim, a motor vehicle investigator shall review the claim.

(3) If the department receives no response from the owner of record within ten days after the date of mailing, the owner of record waives all rights or claims; or if the letter is returned as undeliverable, the department shall continue processing the bond application.

(4) If one or more security interests are found and can be identified, the department shall send a certified letter and application for cancellation of security interest to a lienholder to the last-known address of that lienholder. If a lienholder releases the lien, the department shall continue to process the application. If a lienholder responds with a request to claim the vehicle, the department will review the claim. If the certified letter is returned as undeliverable, the department shall continue to process the application.

(5) If one or more security interests is found but a lienholder cannot be identified because the record is held by another jurisdiction, the department shall return the application to the applicant and inform the applicant which jurisdiction holds the record(s) to the vehicle.

c. If the department determines that the applicant has complied with this rule, that there is sufficient evidence to indicate that the applicant is the rightful owner, and that there is no known unsatisfied security interest, the department shall determine the current value of the vehicle and notify the applicant to deposit cash or file a surety bond with the department in an amount equal to one and one-half times the current value of the vehicle.

d. After the cash deposit or surety bond has been deposited, a motor vehicle investigator of the department may examine the vehicle to verify the information submitted on the application is correct. The owner of the vehicle may drive or tow the vehicle to and from the examination location after completing an affidavit to drive on a form provided by the department. The form shall state that the vehicle is reasonably safe for operation, and the form must be signed by the owner. After verifying the information, the investigator shall authorize the county treasurer to issue a title for and register the vehicle. Should the vehicle not meet the equipment requirements of Iowa Code chapter 321, the investigator shall authorize the county treasurer to issue a title and registration but instruct the county treasurer to immediately suspend the registration until such time as the vehicle meets these equipment requirements. If applicable, the investigator shall also affix an assigned vehicle identification number to the vehicle.

e. The applicant shall then make application for a certificate of title and registration.

**400.13(2) Disapproval.** If the department determines that the applicant has not complied with this rule, that there is sufficient evidence to indicate that the applicant may not be the rightful owner, or that there is an unsatisfied security interest, then the department shall not authorize issuance of a certificate of title or registration receipt and shall notify the applicant in writing of the reason(s).

**400.13(3) Junked vehicle.** A certificate of title shall not be reinstated for a vehicle that has been issued a junking certificate unless the junking certificate was issued in error, as explained in rule 761—400.23(321), or the vehicle qualifies as an antique vehicle under Iowa Code subsection 321.115(1).

This rule is intended to implement Iowa Code sections 321.24 and 321.52.

[ARC 9048B, IAB 9/8/10, effective 10/13/10; ARC 0136C, IAB 5/30/12, effective 7/4/12; ARC 3999C, IAB 9/12/18, effective 10/17/18; ARC 4960C, IAB 3/11/20, effective 4/15/20; ARC 6287C, IAB 4/6/22, effective 5/11/22]

**761—400.14(321) Transfer of ownership.** The following procedures shall apply for all titling and registration purposes:

**400.14(1) Transfer of vehicle owned by two or three persons.**

a. If the names of the owners of a vehicle on the certificate of title or on the manufacturer's certificate of origin are joined by the word "or," as in "John Doe, Jane Doe or Mary Doe," then the signature of any of these owners is sufficient to transfer title or to junk the vehicle.

b. If ownership of a vehicle is stated as a name or names followed by the words "Doing Business As" or the initials "DBA" and another name, only the name of an owner followed by the signature of an authorized representative of an owner is required to transfer title or to junk the vehicle.

EXAMPLE: Ownership is stated as "John Smith and Mary Smith DBA Smith Repair." Jane Doe is an authorized representative of John Smith and Mary Smith. To transfer ownership, Jane Doe may sign as "John Smith and Mary Smith DBA Smith Repair, by Jane Doe," "John Smith and Mary Smith by Jane Doe," or "Smith Repair by Jane Doe."

c. In all other cases the signature of each named owner is required.

**400.14(2) Assignment of title to two or three persons.** If a certificate of title or a manufacturer's certificate of origin is assigned to two or three persons with their names joined by the word "or," as in "John Doe, Jane Doe or Mary Doe," then a certificate of title may be issued to any one of these persons, or to any two or all three of these persons with their names joined by the word "or." However, a certificate of title shall only be issued to persons who have signed the application for title.

**400.14(3) Organizational ownership.**

a. When a vehicle is owned by a partnership, corporation, association, governmental unit, or private organization, the signature of its authorized representative is required.

b. When a vehicle is owned by a trust, the title shall be accompanied by a copy of all documents creating or otherwise affecting the trust or by the certification of trust as defined in Iowa Code section 633A.4604.

(1) The certification of trust may be signed by any trustee or the attorney for any trustee.

(2) The title shall be signed by the number of trustees as specified in the trust agreement, and the transferor shall provide the department with the document or the certification of trust specifying the required signatories for the trust.

(3) If a certification of trust is provided, one of the following shall apply:

1. Any currently acting trustee may sign the title if the certification of trust states that such trustee may act individually.

2. A majority of the trustees must sign the title if the certification of trust states that the trustees must act by majority decision.

3. All currently acting trustees must sign the title if the certification of trust states that the trustees must act by unanimous decision.

(4) A certification of trust must meet the requirements of Iowa Code section 633A.4604, including but not limited to providing the names of all the currently acting trustees. If there are two or more currently acting trustees, the certification of trust must state whether the trustees may act individually, whether the trustees must act by majority decision or whether the trustees must act by unanimous decision. If the certification of trust does not meet said requirement, the certification of trust will be considered invalid for the purposes of the transfer.

(5) Each signature on the title shall be followed by the words "as trustee."

**400.14(4) *Death with a will.*** When ownership is transferred according to a decedent's will, a certified copy of the court order or the letter of appointment appointing the person assigning the title as executor of the will shall be required.

**400.14(5) *Death without a will.*** When ownership is transferred from a decedent without a will and there is no administration of the estate, an affidavit of death intestate form signed by the clerk of court shall be required. When ownership is transferred from a decedent without a will but there is an administration of the estate, a copy of the court order or the letter of appointment appointing the person assigning the title as administrator shall be required.

**400.14(6) *Power of attorney.*** An attorney in fact may act for the owner(s) if the appointment is shown on a power of attorney form. Power of attorney forms are available from the department but other forms may be accepted if they contain all necessary information. The power of attorney form or a certified true copy shall be kept by the county treasurer and attached to the document to which it applies.

This rule is intended to implement Iowa Code sections 321.20, 321.24, 321.45, 321.47, 321.49, 321.67 and 633A.4604.

[ARC 9048B, IAB 9/8/10, effective 10/13/10; ARC 4960C, IAB 3/11/20, effective 4/15/20; ARC 6219C, IAB 3/9/22, effective 4/13/22]

#### **761—400.15(321) Cancellation of a certificate of title.**

**400.15(1)** The department shall cancel a certificate of title when authorized by any provision of law or when it has reasonable grounds to believe that the title has not been surrendered to the county treasurer as provided in Iowa Code section 321.52 or when the vehicle has been stolen or embezzled from the rightful owner or seized under the provisions of Iowa Code section 321.84, and the person holding the certificate of title, purportedly issued for the vehicle, has no immediate right to possession of the vehicle.

**400.15(2)** The decision to issue a new certificate of title or to allow the previous title to be reinstated through a replacement title application process or to take any other action regarding ownership of the vehicle for which the current title has been canceled shall be determined after an investigation and recommendation by a motor vehicle investigator of the department.

This rule is intended to implement Iowa Code section 321.101.

#### **761—400.16(321) Application for certificate of title or original registration for a specially constructed, reconstructed, street rod or replica motor vehicle.**

**400.16(1) *Definitions applicable to this rule.***

*a.* "Ownership document for the vehicle" means the certificate of title, the manufacturer's certificate of origin, the junking certificate, or other evidence of ownership acceptable to the department.

*b.* "Ownership documents for essential parts" means bills of sale for all essential parts used to construct or reconstruct the vehicle. Each bill of sale shall contain a description of the part, the manufacturer's identification number of the part, if any, and the name, address, and telephone number of the seller.

**400.16(2) *Procedures.*** This subrule describes the procedures for obtaining department approval to title and register a specially constructed, reconstructed, street rod or replica motor vehicle. The procedures described are in addition to the regular procedures for titling and registering a vehicle.

*a.* The applicant shall apply to the county treasurer for a certificate of title and registration, including, when applicable, the county treasurer of a contiguous county to the county designated for the owner under Iowa Code section 321.20(1) for registration and issuance of a certificate of title. The county treasurer, upon receiving an application that indicates the vehicle is a specially constructed, reconstructed, street rod or replica motor vehicle, shall forward the application to a motor vehicle investigator of the department.

*b.* The investigator shall contact the applicant and schedule a time and place for an examination of the vehicle and the ownership documents. The owner of the vehicle may drive or tow the vehicle to and from the examination location by completing an affidavit to drive on a form provided by the department. The form shall state that the vehicle is reasonably safe for operation and must be signed by the owner. The applicant, when appearing with the vehicle for the examination, shall submit to the investigator the ownership document for the vehicle, the ownership documents for

essential parts, and a weigh ticket indicating the weight of the vehicle. However, a weigh ticket is not required for motorcycles, autocycles, trucks, truck tractors, road tractors or trailer-type vehicles.

c. If the investigator determines that the vehicle complies with 761—Chapter 450, that the integral parts and components have been identified as to ownership, and that the application has been completed properly:

(1) The investigator shall approve the application, affix to the vehicle an assigned vehicle identification number, and return the application and ownership documents to the applicant. The investigator shall authorize the county treasurer to issue a title and registration for the vehicle.

(2) If the vehicle is a passenger-type motor vehicle, the department shall determine its weight and value. The department shall also determine if the vehicle is subject to the electric vehicle annual registration fee. The vehicle weight shall be fixed at the next even 100 pounds above the actual weight of the vehicle fully equipped, as provided in Iowa Code section 321.162. The weight and value shall constitute the basis for determining the annual registration fee under Iowa Code section 321.109, except as provided in Iowa Code section 321.113.

(3) The applicant shall then submit the ownership document for the vehicle to the county treasurer and continue with the regular title and registration process.

**400.16(3) Disapproval.** If the department determines that the vehicle does not comply with 761—Chapter 450, that the integral parts or components have not been identified as to ownership, or that the application has not been completed properly, then the department shall not approve the vehicle for titling and registration.

**400.16(4) Model year.** The model year of a specially constructed or reconstructed motor vehicle is the year the vehicle is approved by the department as a specially constructed or reconstructed motor vehicle.

This rule is intended to implement Iowa Code sections 321.20, 321.23, 321.24, 321.52, 321.109, 321.116, 321.117 and 321.162.

[ARC 9048B, IAB 9/8/10, effective 10/13/10; ARC 0136C, IAB 5/30/12, effective 7/4/12; ARC 2985C, IAB 3/15/17, effective 4/19/17; ARC 3999C, IAB 9/12/18, effective 10/17/18; ARC 5178C, IAB 9/9/20, effective 10/14/20; ARC 6287C, IAB 4/6/22, effective 5/11/22]

**761—400.17(321) Remanufactured vehicle.** Rescinded IAB 11/23/05, effective 12/28/05.

**761—400.18(321)** Rescinded IAB 3/26/97, effective 4/30/97.

**761—400.19(321) Temporary use of vehicle without plates or registration card.**

**400.19(1) Temporary use of vehicle without plates.** A person who acquires a vehicle which is currently registered or in a dealer's inventory at the time of sale and who does not possess registration plates which may be assigned to and displayed on the vehicle may operate or permit the operation of the vehicle not to exceed 30 days from the date of purchase or transfer without registration plates displayed thereon, if ownership evidence is carried in the vehicle.

**400.19(2) Temporary use of vehicle without registration card.** A person who acquires a vehicle which is currently registered or in a dealer's inventory at the time of sale and who has possession of plates which may be attached to the vehicle acquired may operate or permit the operation of the vehicle not to exceed 45 days from the date of delivery or transfer without a registration card, if ownership evidence is carried in the vehicle.

**400.19(3) Ownership evidence.** Ownership evidence under this rule shall consist of the certificate of title or registration receipt, or a photocopy thereof, properly assigned to the person who has acquired the vehicle, or a bill of sale conveying ownership of the vehicle to the person who has acquired the vehicle. The ownership evidence shall be shown to any peace officer upon request.

This rule is intended to implement Iowa Code sections 321.25 and 321.46.

[ARC 6287C, IAB 4/6/22, effective 5/11/22]

**761—400.20(321) Registration of motor vehicle weighing 55,000 pounds or more.** When applying for registration or renewal of registration for a motor vehicle weighing 55,000 pounds or more, the owner shall present to the department or to the county treasurer proof of compliance with the federal heavy vehicle use tax required by 26 U.S.C. Section 4481 and 26 CFR Part 41.

**400.20(1)** If the motor vehicle is used exclusively in the transportation of harvested forest products, the owner may present a written statement certifying that usage and the usage will be recorded.

**400.20(2)** If the motor vehicle is used primarily for farming purposes, the owner may present a written statement certifying that usage and the usage will be recorded.

This rule is intended to implement Iowa Code sections 307.30 and 321.20.

**761—400.21(321) Registration of vehicles on a restricted basis.** The department may register a vehicle which does not meet the equipment requirements of Iowa Code chapter 321, due to the particular use for which it is designed or intended, or which is a driverless-capable vehicle as defined in rule 761—380.2(321). Registration may be

accomplished upon payment of the appropriate fees and after inspection and certification by the department that the vehicle is not in an unsafe condition.

**400.21(1)** Operation of the vehicle may be restricted to a roadway to which a specific lawful speed limit applies, as specified in Iowa Code section 321.285, if the maximum speed of the vehicle is such that the operation of the vehicle would impede or block the normal and reasonable movement of traffic.

**400.21(2)** The department may also restrict the operation of the vehicle to daylight hours if operation of the vehicle during hours other than daylight would create a hazard.

**400.21(3)** A certificate of restriction shall be issued in conjunction with registration of the vehicle, listing the restrictions that apply to the operation of the vehicle.

*a.* Registration laws applicable to motor vehicles in general shall also apply to vehicles registered under a restricted registration.

*b.* The department may approve exceptions to those equipment requirements of Iowa Code chapter 321 which cannot be met due to the particular use for which the vehicle is designed or intended.

**400.21(4)** The department shall not register an all-terrain vehicle. The department shall not register a vehicle built on or after January 1, 1968, unless it was manufactured primarily for use on public streets, roads and highways except a vehicle operated exclusively by a person with a disability, which may be registered if the department, in its discretion, determines that the vehicle is not in an unsafe condition. This subrule does not apply to a specially constructed, reconstructed, street rod or replica motor vehicle as defined in Iowa Code section 321.1.

**400.21(5)** When a vehicle registered in this state is modified to make it a driverless-capable vehicle as defined in rule 761—380.2(321), the person in whose name the vehicle is registered shall within 30 days notify the department upon a form prescribed by the department.

**400.21(6)** As provided in Iowa Code sections 321.515 and 321.519, the department may restrict the operations of a driverless-capable vehicle registered in this state or another state but which operates in this state. The restrictions may include but are not limited to the restrictions provided in subrules 400.21(1) and 400.21(2) and any operational restrictions based on a specific functional highway classification, weather conditions, days of the week, times of day, and other elements of operational design while the automated driving system is engaged. The department may require the vehicle owner to submit to the department the automated driving system's intended operational design domain for the vehicle on a form prescribed by the department. The department may evaluate the automated driving system's intended operational design domain for the vehicle. The department may establish additional operational restrictions to ensure safe operation of the vehicle. The department shall issue a certificate of restriction as provided in subrule 400.21(3) for any restriction established under this subrule, and the certificate shall be carried in the vehicle and made available for inspection by any peace officer upon request.

This rule is intended to implement Iowa Code sections 321.1, 321.23(4), 321.30(2), 321.101(1), 321.234A, 321.515 and 321.519.

[ARC 9048B, IAB 9/8/10, effective 10/13/10; ARC 5893C, IAB 9/8/21, effective 10/13/21]

**761—400.22(321) Transfers of ownership by operation of law.** When ownership of a vehicle is transferred by operation of law under Iowa Code section 321.47, the following, in addition to rule 761—400.4(321), shall apply:

**400.22(1)** The new certificate of title and registration shall be issued, upon receipt of the proper documentation, by the county treasurer of the county where the transferee resides.

**400.22(2)** If the vehicle is not currently registered in this state, the registration fee and penalties due shall be computed in accordance with the following:

*a.* If the vehicle is ordered confiscated or forfeited by a court under a judgment or forfeiture, the fee shall be computed on the remaining unexpired months in the registration year from the date of the court order.

*b.* If the vehicle is sold on a peace officer's bill of sale as an unclaimed, stolen, embezzled or abandoned vehicle, or as a vehicle seized under Iowa Code section 321.84, the fee shall be computed on the remaining unexpired months in the registration year from the date of the sale.

*c.* If the vehicle is sold or transferred under a judgment or order entered by a court in a civil action or proceeding, or is transferred under any provision of Iowa Code section 321.47 which is not covered in this subrule, the fee shall include any delinquent fees which have accrued during previous registration periods and accrued penalties. Penalties shall continue to accrue until paid.

*d.* If the vehicle was last titled or registered in a foreign state, the fee shall be based on the month the vehicle becomes subject to registration in this state, except as provided in paragraphs 400.22(2) "a" and "b" above.

This rule is intended to implement Iowa Code sections 321.47, 321.105, 321.106, 321.134, and 321.135.

**761—400.23(321) Junked vehicle.**

**400.23(1) *Junking certificate.*** The owner of a vehicle that is to be junked or dismantled shall obtain a junking certificate when required by Iowa Code section 321.52.

**400.23(2) *Required verification.***

*a.* One of the following shall satisfy the required verification when a vehicle owner junks or dismantles a vehicle to a licensed vehicle recycler under Iowa Code section 321.52(2) “b” or 321H.4A(2) “b”:

(1) The owner or authorized representative provides information to the licensed vehicle recycler who acquires the vehicle, including, at a minimum, government-issued photo identification and verification of prior reporting to the National Motor Vehicle Title Information System (NMVTIS). For a subsequent transaction with the licensed vehicle recycler, the vehicle owner or authorized representative is not required to provide government-issued photo identification if the licensed vehicle recycler has retained such information from a prior transaction. A licensed vehicle recycler is not required to report a vehicle verified under this subparagraph to the NMVTIS.

(2) The vehicle’s owner is a licensed vehicle recycler or is the authorized representative of an established commercial or industrial business, operating from a fixed location, that is known to the licensed vehicle recycler to be regularly engaged in the junking or dismantling of vehicles or may reasonably be expected to produce vehicles for junking or dismantling and has entered into a written agreement with the licensed vehicle recycler confirming it has reported the vehicles to the NMVTIS. The written agreement shall, at a minimum, contain the owner’s or authorized representative’s name and address. A licensed vehicle recycler is not required to report a vehicle covered under an agreement under this subparagraph to the NMVTIS.

(3) The licensed vehicle recycler obtains the vehicle owner’s or authorized representative’s name and the vehicle identification number for the vehicle being junked or dismantled, and the vehicle recycler reports the vehicle to the NMVTIS.

*b.* A licensed vehicle recycler acquiring a vehicle as described under this subrule shall cooperate with a law enforcement agency during normal business hours when the agency has reason to believe that fraud has occurred in connection with the junking or dismantling of the vehicle. A law enforcement agency shall maintain the information as confidential and shall not disclose the information to a third party, except as may be necessary for the prosecution of a criminal violation.

**400.23(3) *Retitling a junked vehicle.*** The department may authorize issuance of a new certificate of title to the vehicle owner named on the junking certificate only if the department determines that the junking certificate was issued in error.

*a.* The reasons a junking certificate was issued in error include but are not limited to the following:

(1) The owner inadvertently surrendered the wrong certificate of title. The owner shall submit to the department a photocopy of the ownership document for each vehicle and a signed statement explaining the circumstances that resulted in the error.

(2) A junking certificate was obtained in error and the vehicle continues to be registered. The owner shall submit to the department a photocopy of the current registration and a signed statement explaining the circumstances that resulted in the error.

(3) The owner intended to apply for a salvage title under Iowa Code subsection 321.52(4) but inadvertently submitted an application for a junking certificate. The owner shall submit to the department a bill of sale or other documentation from the previous owner stating that the vehicle was rebuildable when purchased and a signed statement explaining the owner’s original intention to obtain a salvage title. The department shall inspect the vehicle to verify the rebuildable condition.

*b.* If the department determines that the junking certificate was issued in error, the department shall authorize the proper county treasurer to issue a certificate of title for the vehicle after payment by the owner of appropriate fees and taxes, including the return of any credit or refund for registration fees paid to the owner because of the error.

*c.* If the department determines that the junking certificate was not issued in error and denies the application for reinstatement of the certificate of title for the vehicle, the owner may apply for a certificate of title under the bonding procedure in rule 761—400.13(321) if the vehicle qualifies as an antique vehicle under Iowa Code subsection 321.115(1).

This rule is intended to implement Iowa Code sections 321.52 and 321H.4A.

[ARC 6489C, IAB 9/7/22, effective 10/12/22]

**761—400.24(321) New vehicle registration fee.** The registration fee shall be computed on the month of purchase of a new vehicle, except that the registration fee on a new vehicle acquired outside of this state shall be based on the month that the vehicle was brought into Iowa.

This rule is intended to implement Iowa Code sections 321.105 and 321.135.

**761—400.25(321) Fees established by the department.** If the department cannot obtain the retail list price and weight for a particular motor vehicle model registered under Iowa Code subsection 321.109(1), the department shall determine a list price and weight.

This rule is intended to implement Iowa Code sections 321.109, 321.157 and 321.159.

**761—400.26(321) Anatomical gift.** Voluntary contributions collected by the county treasurer or the department to the anatomical gift public awareness and transplantation fund shall be in whole dollar amounts. The county treasurer and the department shall remit contributions collected monthly to the funds specified in Iowa Code section 321.44A.

This rule is intended to implement Iowa Code section 321.44A.

[ARC 6287C, IAB 4/6/22, effective 5/11/22]

**761—400.27(321,322) Vehicles held for resale or trade by dealers.** A motor vehicle dealer, as defined in Iowa Code section 321.1, is authorized to hold a motor vehicle for resale or trade under the following conditions.

**400.27(1) Assignment to dealer.** The certificate of title or manufacturer's certificate of origin for the vehicle shall be assigned to the dealer by the seller. The seller shall complete the assignment portion of the form, including the date of sale or trade and the name and address of the dealer, and shall sign the form. The date of the sale or trade shown in the assignment portion of the form shall be the date the dealer acquired the vehicle.

**400.27(2) New certificate of title and registration not required.**

*a.* A motor vehicle currently registered in Iowa may be held by a dealer without obtaining a new certificate of title or a new registration if the dealer holds for that vehicle a certificate of title or a manufacturer's certificate of origin properly assigned to the dealer.

*b.* A motor vehicle may also be held by a dealer without obtaining a new certificate of title or a new registration if the dealer has a title from a state that permits its titles to be reassigned by Iowa dealers and if a vacant reassignment space is available on the title.

**400.27(3) New certificate of title required.** A dealer shall obtain a new certificate of title, but is not required to pay registration fees for a vehicle if:

*a.* The vehicle has been registered in a foreign state or country that does not permit its titles to be reassigned by Iowa dealers.

*b.* The vehicle was assigned to the dealer using an affidavit of foreclosure form prescribed by the department or issued by a foreign jurisdiction.

*c.* The reassignment area of the certificate of title has been used.

*d.* Reserved.

*e.* The vehicle registration fee was delinquent in Iowa at the time the vehicle was acquired by the dealer. The delinquent fees and penalty shall be paid by the dealer from the first day the registration was due to the month the application for title is submitted.

*f.* In accordance with 761—Chapter 405, the dealer is required to obtain a salvage certificate of title.

**400.27(4) New certificate of title and registration fee required.** A dealer shall obtain both a new certificate of title and pay a registration fee for a vehicle if:

*a.* The vehicle has a foreign certificate of title but has never been registered and the dealer is not licensed under Iowa Code chapter 322 to sell that line-make of vehicle. The registration fee due shall be prorated for the remaining unexpired months of the dealer's registration year.

*b.* The vehicle was placed in storage by the previous owner. The registration fee due shall be a full registration year fee.

*c.* The vehicle has been registered in a foreign state or country that does not permit its titles to be reassigned by Iowa dealers or all reassignment spaces on the title are full and the application for a new certificate of title is submitted more than 30 days after the date the vehicle entered Iowa. The registration fee due shall be prorated for the remaining unexpired months of the dealer's registration year.

*d.* The vehicle was in the dealer's inventory and the dealer's license was revoked as provided in Iowa Code chapter 322 or 322C or surrendered in lieu of revocation. The dealer shall obtain title and registration within 30 days from the date of revocation or surrender of the license. The registration fee due shall be prorated for the remaining unexpired months of the registration year.

**400.27(5) Registration fee required.** A vehicle owned by a dealer and used as a work or service vehicle, or offered for lease, rent or hire, shall become subject to a registration fee in the month that the vehicle is first used for that purpose. The registration fee shall be due annually unless the vehicle is transferred to the dealer's inventory. To transfer the vehicle, the dealer shall surrender the registration plates that were issued for the vehicle.

**400.27(6) Violations.**

*a.* Failure to comply with this rule is a violation of Iowa Code subsection 321.104(2).

*b.* Failure to obtain a certificate of title when required shall result in a title penalty of \$10, as specified in Iowa Code subsection 321.49(1).

This rule is intended to implement Iowa Code sections 321.45, 321.46, 321.48, 321.49, 321.67, 321.70, 321.104 and chapter 322.

[ARC 9048B, IAB 9/8/10, effective 10/13/10]

**761—400.28(321) Special trucks.** The owner of a truck tractor registered as a special truck shall certify to the owner's county treasurer annually at the time of renewal that the truck tractor is not operated more than 15,000 miles annually.

This rule is intended to implement Iowa Code sections 321.1(75) and 321.121.

[ARC 3999C, IAB 9/12/18, effective 10/17/18]

**761—400.29(321) Vehicles previously registered under Iowa Code chapter 326.** Rescinded IAB 11/23/05, effective 12/28/05.

**761—400.30(321) Registration of vehicles registered in another state or country.**

**400.30(1)** The registration fee for a vehicle from another state or country shall be due in the month that the vehicle becomes subject to registration in Iowa.

**400.30(2)** A vehicle registered in another state or country shall become subject to registration in Iowa and payment of the Iowa registration fee in:

*a.* The month of sale or transfer to an Iowa resident, or

*b.* The month that a nonresident owner establishes Iowa residency or accepts employment in Iowa of 90 days duration or longer. The county treasurer or the department may require from the applicant a written statement giving the date that the applicant established residency in Iowa.

**400.30(3)** Rescinded IAB 2/6/02, effective 3/13/02.

This rule is intended to implement Iowa Code sections 321.18, 321.20, 321.53 to 321.55, 321.101 and 321.135.

**761—400.31** Rescinded, effective 12/1/83.

**761—400.32(321) Vehicles owned by nonresident members of the armed services.**

**400.32(1)** A vehicle owner who is a nonresident and a member of the armed services shall not be required to register the vehicle in Iowa if it is properly registered in the person's state of residence.

**400.32(2)** A vehicle owner who is a nonresident and a member of the armed services may register the vehicle in Iowa under the following conditions:

*a.* The vehicle is owned entirely by nonresidents.

*b.* The fee for a passenger-type vehicle registered under Iowa Code section 321.109 shall be based only on the weight of the vehicle; the part of the fee based on value shall be excluded. The fees for all other vehicles shall be determined as specified in Iowa Code chapter 321. The registration fee under Iowa Code sections 321.116 and 321.117 shall apply.

*c.* The application for vehicle registration shall include a certification by the person's commanding officer of the person's state of residence and assignment to Iowa.

**400.32(3)** If ownership of a passenger-type vehicle is transferred to another person, the vehicle shall be subject to registration in Iowa.

This rule is intended to implement Iowa Code sections 321.53 to 321.55, 321.109, 321.116 and 321.117.

[ARC 5178C, IAB 9/9/20, effective 10/14/20]

**761—400.33(321) Disabled veterans exemption from payment of registration fees.** Rescinded IAB 11/23/05, effective 12/28/05.

**761—400.34(321) Multipurpose vehicle registration fee.** Rescinded IAB 11/7/07, effective 12/12/07.

**761—400.35(321) Registration of vehicles equipped for persons with disabilities.** The registration fee shall be reduced for an automobile, multipurpose vehicle, or motor truck with an unladen weight of 10,000 pounds or less with permanent equipment for assisting a person with a disability or for an automobile, multipurpose vehicle, or motor truck with an unladen weight of 10,000 pounds or less used by a person who uses a wheelchair as the person's only

means of mobility. To qualify for the reduction, the owner of the vehicle must provide a written self-certification at the first registration and at each renewal:

**400.35(1)** That the automobile, multipurpose vehicle, or motor truck with an unladen weight of 10,000 pounds or less has permanently installed equipment manufactured for and necessary to assist a person with a disability, as defined in Iowa Code section 321L.1, to enter or exit the vehicle, or

**400.35(2)** That the owner or a member of the owner's household uses a wheelchair as the person's only means of mobility.

This rule is intended to implement Iowa Code sections 321.109, 321.124 and 321L.1.

[ARC 9048B, IAB 9/8/10, effective 10/13/10]

**761—400.36(321) Land and water-type travel trailers registration fee.** The registration fee for trailer-type vehicles designed to be used as a travel trailer and for use upon water shall be registered as a travel trailer. The exterior measurements used to determine the registration fee shall not include any pen deck area or area occupied by a trailer hitch.

This rule is intended to implement Iowa Code sections 321.1 and 321.123.

**761—400.37(321) Motorcycle or autocycle primarily designed or converted to transport property.** A motorcycle or autocycle primarily designed or converted to transport less than 1000 pounds of property shall be registered as a motorcycle or autocycle. A motorcycle or autocycle primarily designed or converted to transport 1000 pounds of property or more shall be registered as a motor truck.

This rule is intended to implement Iowa Code sections 321.1 and 321.117.

[ARC 2985C, IAB 3/15/17, effective 4/19/17]

**761—400.38(321)** Rescinded IAB 3/26/97, effective 4/30/97.

**761—400.39(321) Conversion of motor vehicles.**

**400.39(1)** An automobile converted to a truck with a carrying capacity of 1000 pounds or more shall be registered as a reconstructed motor vehicle.

**400.39(2)** A vehicle manufactured as a truck tractor or motor truck shall not be registered as a motor home unless the vehicle has been substantially altered to change its type and mode of operation so that it is a reconstructed vehicle as defined in Iowa Code section 321.1.

This rule is intended to implement Iowa Code sections 321.23, 321.111 and 321.124.

[ARC 9048B, IAB 9/8/10, effective 10/13/10; ARC 0136C, IAB 5/30/12, effective 7/4/12; ARC 3999C, IAB 9/12/18, effective 10/17/18]

**761—400.40(321) Manufactured or mobile home converted to or from real property.**

**400.40(1)** *Conversion to real property.* When a manufactured or mobile home is converted to real property under Iowa Code section 435.26, the process shall be as follows:

*a.* If a security interest is noted on the title and the secured party is given a mortgage for the land on which the home is located, the assessor shall collect the certificate of title as provided in rule 701—74.5(435).

*b.* If a security interest is noted on the title and the secured party is not given a mortgage for the land on which the home is located, the secured party shall retain the certificate of title as provided in Iowa Code section 435.26. At the time the security interest is released, the secured party may surrender the certificate of title to the county treasurer, who shall cancel the title as converted to real estate and destroy the title.

*c.* If there is no security interest noted on the title, the owner shall surrender the certificate of title to the assessor. The assessor shall note the conversion on the face of the certificate of title above the assessor's signature, date the notation and deliver the title to the county treasurer. The county treasurer shall note the conversion on the vehicle record and then cancel the title as converted to real estate and destroy the certificate of title.

*d.* If the assessor identifies in the county records a security interest no longer exists that would prevent the title to the home and the title to the land to merge under Iowa Code section 435.26 and the county treasurer verifies there is no lien on the certificate of title, the title to the home and the title to the land shall merge, and the county treasurer shall cancel the title as converted to real estate and destroy the certificate of title.

**400.40(2)** *Reconversion from real property.*

*a.* When a manufactured or mobile home is reconverted from real property by adding a vehicular frame, the owner may apply to the county treasurer for a certificate of title.

*b.* The owner shall submit a record of existing liens obtained from a local abstractor. The record shall identify the owner of the property, list all liens and encumbrances against the property, and shall be signed by the abstractor.

c. The owner shall also submit written consent to the reconversion from any person holding a mortgage on the real property (mortgagee). An existing mortgage shall be noted as a security interest on the certificate of title.

d. The county treasurer shall submit written notice of the reconversion to the county assessor's office.

**400.40(3) Affidavit for surrender of certificate of title.**

a. As provided in Iowa Code section 435.26B, an owner may effectuate a surrender of the certificate of title by recording with the county recorder Form 411186 if all of the following requirements are met:

(1) There is no record that a certificate of title has been issued or surrendered for a manufactured or mobile home that is located outside a manufactured home community or mobile home park.

(2) The manufactured home or mobile home has been converted to real estate by being placed on a permanent foundation.

(3) The manufactured or mobile home is entered on the tax rolls.

b. The fee for the duties performed by the department pursuant to Iowa Code section 435.26B(1) "i"(2) shall be \$5.

This rule is intended to implement Iowa Code sections 321.1, 435.1, 435.26, 435.26A, 435.26B and 435.27.

[ARC 3999C, IAB 9/12/18, effective 10/17/18; ARC 6287C, IAB 4/6/22, effective 5/11/22]

**761—400.41(321) Special registration plates.** Rescinded IAB 3/1/95, effective 4/5/95.

**761—400.42(321) Church bus registration fee.** The church bus registration fee shall not apply if the bus is used in a manner other than provided by law or if ownership of the bus is transferred to a person who is not entitled to register the vehicle as a church bus.

**400.42(1)** When the church bus registration fee does not apply, the bus shall be registered under the provisions of Iowa Code section 321.122.

**400.42(2)** When Iowa Code section 321.122 applies and the bus is currently registered as a church bus, the registration fee shall be prorated for the remaining unexpired months of the registration year.

This rule is intended to implement Iowa Code sections 321.119 and 321.122.

**761—400.43(321) Storage of vehicles.**

**400.43(1)** The owner of a vehicle upon which the registration fee is not delinquent may surrender all registration plates for the vehicle to the county treasurer where the vehicle is registered and shall have the right to register the vehicle later upon payment of the annual registration fee due at the time of removal of the vehicle from storage. Payment of a registration fee shall not be required when the vehicle is removed from storage within the current registration year provided that registration fees have not been refunded. Plates that have been surrendered shall be destroyed. When a vehicle is removed from storage, the fee is \$5 for a set of replacement plates.

**400.43(2)** The owner of a motor vehicle which is placed in storage when the owner enters the military service of the United States shall comply with Iowa Code section 321.126, and subrule 400.43(1) does not apply.

This rule is intended to implement Iowa Code sections 321.126 and 321.134.

[ARC 9048B, IAB 9/8/10, effective 10/13/10; ARC 3999C, IAB 9/12/18, effective 10/17/18]

**761—400.44(321) Penalty on registration fees.**

**400.44(1) Monthly basis.** The penalty on the delinquent payment of a registration fee shall be computed on a monthly basis, rounded to the nearest whole dollar. If multiple penalties are assessed, the penalties shall be first added together and then the sum shall be rounded to the nearest whole dollar.

**400.44(2) Vehicle purchased.** The penalty on the registration fee shall accrue from the first day of the month following the date of purchase, unless the application for a certificate of title is submitted within 30 days after the date of purchase.

**400.44(3) Vehicle moved into Iowa.** The penalty on the registration fee shall accrue on the first day of the month following 30 days from the date a vehicle is moved into Iowa.

**400.44(4) When delinquency extends beyond the current year.** When the penalty on a delinquent registration fee extends beyond the current year, the penalty shall continue to accrue until paid. Penalty shall only accrue on the fee applicable at the time the delinquency accrued and shall not be applicable to subsequent registration fees which have not been paid.

**400.44(5) Statement of nonuse.** If the owner of a vehicle, on which the registration fees have not been paid for more than three complete registration years, certifies to the county treasurer of the owner's residence, or to the department in a form and manner prescribed by the department if a vehicle is registered under Iowa Code chapter 326,

that the vehicle has not been moved or operated upon the highway since the year it was last registered, the vehicle may be registered upon payment of the current year's registration fee.

**400.44(6)** *Waiver of penalties for military members.* Registration penalties shall be waived as provided in Iowa Code section 321.134, subsection 5, if the owner provides a copy of an official government document verifying that the applicant is in the military service of the United States and has been relocated as a result of being placed on active duty on or after September 11, 2001.

This rule is intended to implement Iowa Code sections 321.39, 321.46, 321.47, 321.49, 321.134 and 321.135.

[ARC 5178C, IAB 9/9/20, effective 10/14/20; ARC 6287C, IAB 4/6/22, effective 5/11/22]

**761—400.45(321) Suspension, revocation or denial of registration.**

**400.45(1)** The department shall suspend or revoke registration and plates under Iowa Code section 321.101 when a written request is received from a peace officer or the county treasurer's office that issued the registration or plates.

a. The notice of suspension or revocation shall contain the following:

(1) The basis of the request for suspension or revocation.

(2) Information regarding how the person may satisfy the violation and have the suspension or revocation removed, if applicable.

(3) Information notifying the person of the right to appeal the suspension or revocation in accordance with rule 761—400.56(321).

b. A request from a peace officer shall be submitted on a form prescribed by the department.

c. A request from a county treasurer's office shall be signed by the county treasurer or designee.

**400.45(2)** When the registration of a vehicle has been revoked as provided in Iowa Code sections 321.101 and 321.101A, the registration fee and penalty shall accrue as if the plates had never been issued, unless waiver of registration fees and penalties is specifically provided for in Iowa Code chapter 321.

**400.45(3)** In accordance with Iowa Code section 252J.8, the department shall suspend or deny the issuance or renewal of registration and plates upon receipt of a certificate of noncompliance from the child support recovery unit.

a. The suspension or denial shall become effective 30 days after notice to the vehicle owner and continue until the department receives a withdrawal of the certificate of noncompliance from the child support recovery unit.

b. If a person who is the named individual on a certificate of noncompliance subsequently purchases a vehicle, the vehicle shall be titled and registered, but the registration shall be immediately suspended.

This rule is intended to implement Iowa Code sections 252J.1, 252J.8, 252J.9, 321.101, 321.101A and 321.127.

[ARC 3999C, IAB 9/12/18, effective 10/17/18; ARC 4758C, IAB 11/6/19, effective 12/11/19; ARC 6287C, IAB 4/6/22, effective 5/11/22]

**761—400.46(321) Termination of suspension of registration.** Upon termination of the suspension of registration of a vehicle, the county treasurer shall issue new plates for the vehicle. If the new plates replace a current series of plates, there shall be a replacement fee as provided in Iowa Code section 321.42. If the vehicle is not currently registered at the time the suspension is lifted, the registration fee and penalties due shall be determined as follows:

**400.46(1)** If the registration fee was delinquent at the time that the suspension became effective, the penalty shall continue to accrue on the registration fee until the suspension became lifted and the registration fee is paid. In addition, if the suspension was for failure to pay an additional registration fee, the additional registration fee shall be paid before the suspension is lifted.

**400.46(2)** If the registration fee was not delinquent when the suspension became effective and the suspension is lifted after the beginning of another registration year, the annual registration fee for that year shall be due in the month the suspension is lifted. The penalty shall accrue on the registration fee the first day of the month following the month that the suspension was lifted. The annual registration fee on a recovered stolen vehicle for which the registration has been suspended shall be prorated for the remaining unexpired months of the registration year.

**400.46(3)** If the registration fee was not delinquent at the time that the suspension became effective and the suspension is lifted during the same registration period, no additional registration fees shall be due unless the suspension was for failure to pay an additional registration fee, in which event the additional registration fee shall be paid before the suspension is lifted.

This rule is intended to implement Iowa Code sections 321.42, 321.105 and 321.134.

**761—400.47(321) Raw farm products.** A vehicle may be operated with a gross weight of 25 percent in excess of the gross weight for which it is registered when transporting a load of raw farm products or soil fertilizers under Iowa Code section 321.466 except that nothing in this rule shall be construed to allow operation of a special truck on the public highways with a gross weight exceeding the maximum gross weight allowed under Iowa Code section

321.463(6). In addition, the following products shall be considered raw farm products. This list shall not be deemed conclusive and shall not exclude other commodities which might be considered raw farm products:

|                                  |                          |
|----------------------------------|--------------------------|
| Animals which are dead           | Hides                    |
| Berries, fresh                   | Honey, comb or extracted |
| Blood                            | Melons                   |
| Corn, ear corn including hybrids | Milk, raw                |
| Corn, shelled                    | Nursery stock            |
| Corn, cobs                       | Potatoes                 |
| Cream, separated                 | Peat                     |
| Eggs, fresh or frozen in shell   | Poultry, live            |
| Flax                             | Saw logs                 |
| Flaxseed                         | Sod                      |
| Fodder                           | Soybeans                 |
| Fruit, fresh                     | Straw, baled or loose    |
| Grain, threshed or unthreshed    | Vegetables, fresh        |
| Hair                             | Wood, cord or stove wood |
| Hay, baled or loose              | Wool                     |

This rule is intended to implement Iowa Code sections 321.466(4) and 321.466(5).

[ARC 3999C, IAB 9/12/18, effective 10/17/18; ARC 4960C, IAB 3/11/20, effective 4/15/20]

**761—400.48(321) Special mobile equipment.** Rescinded IAB 3/7/90, effective 4/11/90.

**761—400.49(321) Special mobile equipment transported on a registered vehicle.** Rescinded IAB 3/7/90, effective 4/11/90.

**761—400.50(321,326) Refund of registration fees.**

**400.50(1) Vehicles registered by county treasurer.**

*a.* The department shall refund annual registration fees for vehicles registered by the county treasurer pursuant to Iowa Code section 321.126.

*b.* Except as provided in Iowa Code section 321.126, the owner may submit a claim for refund to the county treasurer's office in any county.

*c.* Registration plates shall be submitted with the claim if the vehicle is placed in storage or registered for apportioned registration, if the owner of the vehicle moves out of state, or if the plates have not been assigned to a replacement vehicle. If one or both plates have been lost or stolen, the claimant shall certify this fact in writing.

*d.* For a vehicle that was junked, the date on the junking certificate shall determine the date the vehicle was junked.

*e.* If the claim for refund is for excess credit or no replacement vehicle:

(1) The county treasurer shall enter into the state motor vehicle computer system the information required to process the refund. The information shall be entered within three days of receipt of the claim for refund.

(2) The claim for refund shall be approved or denied by the motor vehicle division.

*f.* The county treasurer shall forward all other claims for refund to the motor vehicle division for processing in the form and manner prescribed by the department.

**400.50(2) Vehicles registered by the department.** Forms and instructions for claiming a refund on apportioned registration fees under Iowa Code section 326.15 may be obtained from the motor vehicle division at the address in subrule 400.6(1). The claim for refund shall be filed at the same address.

This rule is intended to implement Iowa Code sections 25.1, 321.126 through 321.129 and 326.15.

[ARC 3999C, IAB 9/12/18, effective 10/17/18; ARC 4960C, IAB 3/11/20, effective 4/15/20; ARC 6287C, IAB 4/6/22, effective 5/11/22]

**761—400.51(321) Assigned identification numbers.** The department is authorized to issue to the owner an assigned vehicle identification number for a vehicle, an assigned component part number for a component part, and an assigned product identification number for a fence-line feeder, grain cart, or tank wagon. An identification number shall be assigned only if the department is satisfied as to the true identity and ownership of the vehicle, component part, fence-line feeder, grain cart or tank wagon. When an assigned vehicle identification number has been issued for a vehicle, the vehicle shall be registered and titled under that number. An assigned component part number or an assigned product identification number shall be used only for identification purposes.

**400.51(1)** *Issuance of an identification number.* The department shall issue an assigned vehicle identification number, assigned component part number or assigned product identification number, as applicable, only if:

*a.* The original number has been destroyed, removed or obliterated.

*b.* The vehicle has had a cab, body, or frame change and the replacement cab, body, or frame is within the manufacturer's interchangeability parts specifications catalog and is compatible with the make, model, and year of the vehicle. If the replacement cab, body, or frame change is not within the manufacturer's interchangeability parts specifications catalog or is not compatible with the make, year, and model of the vehicle, the vehicle shall be considered reconstructed and subject to rule 761—400.16(321).

*c.* The vehicle is a specially constructed, reconstructed, street rod or replica motor vehicle. See rule 761—400.16(321) for the requirements and procedures applicable to specially constructed, reconstructed, street rod or replica motor vehicles.

**400.51(2)** *Procedures.*

*a. Request.* Whenever an assigned identification number is required under subrule 400.51(1) and the request does not apply to a specially constructed, reconstructed, street rod or replica motor vehicle, the owner of the vehicle, component part, fence-line feeder, grain cart or tank wagon, or the person holding lawful custody, shall contact the department's bureau of investigation and identity protection at the address in subrule 400.6(2) and request the assignment of a number.

*b. Examination.* A motor vehicle investigator shall contact the owner and schedule a time and place for examination of the vehicle, component part, fence-line feeder, grain cart or tank wagon and ownership documents. The owner of the vehicle may drive or tow the vehicle to and from the examination location by completing the affidavit to drive section on the certification of compliance form. The affidavit shall state that the vehicle is reasonably safe for operation and must be signed by the owner.

If the vehicle has had a cab, body, or frame change, the owner shall have, for evidence of ownership for the replacement cab, body, or frame, a bill of sale with a description of the part, complete with the manufacturer's identification number, if any, and the name, address, and telephone number of the seller. The bill of sale, the vehicle, and the cab, body, or frame that has been replaced shall be made available for examination at the time and place scheduled.

*c. Assigned vehicle identification number.*

(1) The investigator upon approval of the request shall affix to the vehicle an assigned vehicle identification number and authorize the county treasurer to issue a title and registration for the vehicle.

(2) The owner shall submit the certificate of title and the registration receipt issued for the vehicle to the county treasurer. If the certificate of title is in the possession of a secured party, the county treasurer shall notify the secured party to return the certificate of title to the county treasurer for the purpose of issuing a corrected title. Upon receipt of the notification, the secured party shall submit the certificate of title within ten days. The county treasurer, upon receipt of the certificate of title and the registration receipt, shall issue a corrected title and registration receipt listing as the vehicle identification number the assigned vehicle identification number.

*d. Assigned component part number.* The investigator upon approval of the request shall affix to the component part an assigned component part number and give to the owner a component part form. The owner shall retain the form as a record of issuance and attachment. The form shall be made available on demand by any peace officer for examination.

*e. Assigned product identification number.* The investigator upon approval of the request shall affix an assigned product identification number to the fence-line feeder, grain cart or tank wagon and give to the owner an assigned product identification number form. The owner shall retain the form as a record of issuance and attachment. The form shall be made available on demand by any peace officer for examination.

**400.51(3)** *Fees.* A certificate of title fee and a fee for a notation of a security interest, if applicable, shall be collected by the county treasurer upon issuance of a corrected certificate of title. A corrected certificate of title shall not be required for a name change.

This rule is intended to implement Iowa Code sections 321.1, 321.43 and 321.92.

[ARC 9048B, IAB 9/8/10, effective 10/13/10; ARC 0136C, IAB 5/30/12, effective 7/4/12; ARC 3999C, IAB 9/12/18, effective 10/17/18]

#### **761—400.52(321) Odometer statement.**

**400.52(1)** Pursuant to Iowa Code section 321.71 and 49 U.S.C. Section 32705, an odometer disclosure statement shall be submitted with an application for certificate of title for a motor vehicle. The statement shall provide a current odometer reading and reflect whether the mileage is "actual," "not actual" or "exceeds mechanical limits."

**400.52(2)** If the transferor failed to provide an odometer disclosure statement or if the transferee lost the statement, and the transferee has attempted in good faith to contact the transferor to obtain a statement, the transferee

may file a sworn statement of these facts on a form prescribed by the department. The sworn statement shall be accepted by the county treasurer or the department in lieu of the required odometer disclosure statement. The subsequent title issued from the sworn statement will record “not actual” mileage.

**400.52(3)** As required by 49 CFR Section 580.17, for vehicle transfers that occur through December 31, 2030, any vehicle that is model year 2011 or newer shall require an odometer disclosure statement. For vehicle transfers that occur on or after January 1, 2031, the model year formula for odometer disclosure statements shall be the current year minus 20. The resulting number represents the first model year for which a motor vehicle is exempt from the odometer statement requirements incident to a transfer.

This rule is intended to implement Iowa Code section 321.71.

[ARC 5829C, IAB 8/11/21, effective 9/15/21]

#### **761—400.53(321) Stickers.**

**400.53(1)** *Placement of validation sticker.* The validation sticker shall be affixed to the lower left corner of the rear registration plate. EXCEPTIONS: For motorcycle, autocycle and small trailer plates, the validation sticker shall be affixed to the upper left corner of the plate. For natural resources plates, the sticker may be affixed to the lower right corner of the rear plate.

**400.53(2)** *Special fuel user identification sticker.* If the vehicle uses a special fuel as defined in Iowa Code section 452A.2, a special fuel user identification sticker shall be issued. This sticker shall be displayed on the cover of the fuel inlet of the motor vehicle or on the outside panel of the motor vehicle within 3 inches of the fuel inlet so as to be in view when fuel is delivered into the motor vehicle.

**400.53(3)** *Persons with disabilities parking sticker.* A persons with disabilities special registration plate parking sticker shall be affixed to the lower right corner of the rear registration plate. A flying our colors plate sticker shall be affixed to the lower left corner of the rear registration plate and above the validation sticker to allow for full view of all numerals and letters printed on the plate pursuant to Iowa Code section 321.37.

**400.53(4)** *Special truck sticker.* An owner of a special truck, registered pursuant to Iowa Code section 321.121, who has been issued either regular registration plates or special registration plates other than special truck registration plates must obtain from the county treasurer a sticker which distinguishes the vehicle as a special truck. The sticker shall be affixed to the lower right corner of the rear registration plate. EXCEPTION: If the vehicle displays front and rear plates, two stickers shall be issued with one sticker affixed to the lower right corner of the front plate and rear plate. For natural resources plates and flying our colors plates, the stickers must be affixed to the lower left corner of the front and rear plates.

This rule is intended to implement Iowa Code sections 321.34, 321.37, 321.40, 321.41, 321.121 and 321.166.

[ARC 9833B, IAB 11/2/11, effective 12/7/11; ARC 2985C, IAB 3/15/17, effective 4/19/17; ARC 3999C, IAB 9/12/18, effective 10/17/18; ARC 6287C, IAB 4/6/22, effective 5/11/22]

**761—400.54(321) Registration card issued for trailer-type vehicles.** The registration card issued for trailer-type vehicles shall be carried in the vehicle which is described on the card or the registration card may be carried in the driver’s compartment of the towing vehicle. If the registration card is carried in the vehicle which is described on such card, the registration card shall be enclosed in a registration card holder and the holder shall be attached to the vehicle so that the registration card may be viewed by any peace officer upon request.

This rule is intended to implement Iowa Code section 321.32.

#### **761—400.55(321) Damage disclosure statement.**

**400.55(1)** If the transferor failed to provide a damage disclosure statement or if the transferee lost the statement, and the transferee has attempted in good faith to contact the transferor to obtain a statement, the transferee may file a sworn statement of these facts. The transferee shall also complete section 2 of a separate damage disclosure statement and sign on the buyer’s line. The sworn statement and damage disclosure statement completed by the transferee shall be accepted by the county treasurer or the department in lieu of the damage disclosure statement required from the transferor.

**400.55(2)** A model year formula for damage disclosure statements shall be the current year minus eight. The resulting number represents the first model year for which a motor vehicle is exempt from the damage disclosure statement requirements incident to a transfer.

**400.55(3)** If the transferor completes the damage disclosure on the assignment of title at the time of application for title, a transferor or transferee of a vehicle may submit a separate damage disclosure statement, Form 411108, indicating the damage level of the vehicle and whether the damage level exceeds 70 percent.

*a.* If the transferor signs both the damage disclosure on the assignment of title and the separate damage disclosure statement, Form 411108, the county treasurer shall accept the separate damage disclosure statement.

b. If the transferee signs the separate damage disclosure statement, Form 411108, the county treasurer shall accept the separate damage disclosure statement only if the separate damage disclosure statement indicates the damage level exceeds 70 percent. If the transferee's statement indicates the damage level is less than 70 percent, and there is no evidence that a prior Iowa title or foreign title was issued or designated as salvage, rebuilt or flood, the department shall review the transaction to confirm the damage level using data obtained from the insurance provider, motor vehicle repair facility, or other entity with direct knowledge of the damage.

This rule is intended to implement Iowa Code sections 321.52 and 321.69.

[ARC 6220C, IAB 3/9/22, effective 4/13/22]

**761—400.56(321) Hearings.** The department shall send notice by certified mail to a person whose certificate of title, vehicle registration, license, or permit is to be revoked, suspended, canceled, or denied. The notice shall be mailed to the person's mailing address as shown on departmental records and shall become effective 20 days from the date mailed. A person who is aggrieved by a decision of the department and who is entitled to a hearing may contest the decision in accordance with 761—Chapter 13. The request shall be submitted in writing to the director of the motor vehicle division at the address in subrule 400.6(1). The request for a contested case shall be deemed timely submitted if it is delivered or postmarked on or before the effective date specified in the notice of revocation, suspension, cancellation, or denial.

This rule is intended to implement Iowa Code sections 17A.10 through 17A.19, 321.101 and 321.102.

[ARC 9048B, IAB 9/8/10, effective 10/13/10; ARC 3999C, IAB 9/12/18, effective 10/17/18; ARC 4960C, IAB 3/11/20, effective 4/15/20; ARC 6287C, IAB 4/6/22, effective 5/11/22]

**761—400.57(321) Non-resident-owned vehicles.** Rescinded IAB 2/6/02, effective 3/13/02.

**761—400.58(321) Motorized bicycles.** The following rules shall apply to motorized bicycles.

**400.58(1) Maximum speed.** If the department has reasonable cause to believe that a particular vehicle or model is capable of speeds exceeding 39 miles per hour, the department may conduct independent tests to determine the maximum speed of the vehicle or model. If the department determines that the maximum speed of the particular vehicle or model exceeds 39 miles per hour, the vehicle or model shall not be registered as a motorized bicycle.

**400.58(2) Identification of a vehicle as a motorized bicycle.** Registration plates issued for motorcycles shall also be issued for motorized bicycles.

This rule is intended to implement Iowa Code sections 321.1 and 321.166.

[ARC 2887C, IAB 1/4/17, effective 2/8/17]

**761—400.59(321) Registration documents lost or damaged in transit through the United States postal service.**

To obtain without cost the reissuance of registration documents that were sent by the county treasurer to the owner through the United States postal service and which were lost or damaged in transit, the owner of the vehicle shall file application for reissuance within 60 days of the date the documents were issued by the county treasurer.

This rule is intended to implement Iowa Code section 321.42.

**761—400.60(321) Credit of registration fees.**

**400.60(1) Credit for unexpired registration fee.** The applicant may claim credit, as specified in Iowa Code section 321.46(3), toward the registration fee for one newly acquired replacement vehicle. No credit shall be given for an unexpired electric vehicle annual registration fee; however, an unexpired electric vehicle annual registration fee is eligible for a refund as provided in rule 761—400.50(321,326).

a. The credit may be claimed only when the owner of the newly acquired vehicle is applying for a certificate of title and registration (or just registration if the vehicle is not subject to titling provisions) for the newly acquired vehicle.

b. For a junked vehicle, the date on the junking certificate shall determine the date the vehicle was junked.

c. Excess credit shall not be applied toward the registration fee for a second vehicle.

d. Credit shall be allowed for one or two vehicles which have been sold, traded or junked toward one replacement vehicle. Credit shall be based on the remaining unexpired months of the registration year(s) of the vehicle(s) sold, traded or junked.

**400.60(2) Credit for transfer to spouse, parent or child.** Credit shall be allowed toward a new registration for a vehicle being transferred to the applicant from the applicant's spouse, parent or child, or from a former spouse pursuant to a dissolution of marriage decree, if application for the certificate of title and registration (or just registration if the vehicle is not subject to titling provisions) is made within 30 days after the date of transfer. If the owner is deceased, credit may be transferred under rule 761—400.14(321) of this chapter.

**400.60(3)** *Credit from/to apportioned registration.*

*a.* Pursuant to Iowa Code section 321.46A, an owner may claim credit toward the registration fees due when changing a vehicle's registration from apportioned registration under Iowa Code chapter 326 to registration under Iowa Code chapter 321. The owner shall surrender proof of apportioned registration to the county treasurer. Credit shall be allowed for the unexpired complete calendar months remaining in the registration year from the date the application is filed with the county treasurer.

*b.* Pursuant to Iowa Code sections 321.126 and 321.127, the owner or lessee of a motor vehicle may claim credit for the apportioned registration fees due when changing the vehicle's registration from registration by the county treasurer to apportioned registration. Application for apportioned registration shall be submitted to the department's motor vehicle division; see 761—Chapter 500.

**400.60(4)** *Assignment of credit and registration plates from lessor to lessee.* When a lessee purchases the leased vehicle and within 30 days requests the assignment of the vehicle's fee credit and registration plates, the lessor shall assign the registration fee credit and registration plates for the purchased vehicle to the lessee.

**400.60(5)** *Rounding.* If credit from two registration years or two registration fees, or some combination of both, is available, the credits shall first be added together, then it shall be determined whether the sum meets the minimum required under Iowa Code section 321.46(3) "c," and then the sum shall be rounded to the nearest whole dollar.

This rule is intended to implement Iowa Code sections 321.46, 321.46A, 321.48, 321.116, 321.117, 321.126 and 321.127.

[ARC 3999C, IAB 9/12/18, effective 10/17/18; ARC 4960C, IAB 3/11/20, effective 4/15/20; ARC 5178C, IAB 9/9/20, effective 10/14/20; ARC 6287C, IAB 4/6/22, effective 5/11/22]

**761—400.61(321) Reassignment of registration plates.**

**400.61(1)** Registration plates may be reassigned if one of the owners listed on the registration receipt before the transfer is also a listed owner following the transfer.

**400.61(2)** Registration plates may be reassigned when credit is allowed toward a new registration for a vehicle being transferred to the owner's spouse, parent, or child, or to a former spouse pursuant to a dissolution of marriage decree. If the owner is deceased, plates may be transferred under rule 761—400.14(321).

**400.61(3)** Registration plates shall not be reassigned between a natural person or persons and a corporation, association, copartnership, company, or firm.

**400.61(4)** Registration plates may be reassigned and credit allowed if two or more corporations, associations, partnerships, or firms merge into one corporation, association, partnership or firm.

**400.61(5)** Registration plates may be assigned and credit allowed if an owner listed on the certificate of title and registration transfers ownership of the vehicle to a trust created by that owner.

This rule is intended to implement Iowa Code sections 321.34 and 321.46.

**761—400.62(321) Storage of registration plates, certificate of title forms and registration forms.** Registration plates, certificate of title forms and registration forms which are consigned to county treasurers by the department shall be stored in a secure location. The location may be within the office of the county treasurer which is accessible only to authorized persons or in a storage area located outside the general office area assigned to the county treasurer. Any storage area located outside the general office area assigned to the county treasurer shall be of the construction that it is accessible only to authorized persons, as designated by the county treasurer or department.

This rule is intended to implement Iowa Code sections 321.5, 321.8, and 321.167.

**761—400.63(321) Disposal of surrendered registration plates.** The county treasurer shall return plates that have been surrendered to the county treasurer to Iowa state prison industries for recycling.

This rule is intended to implement Iowa Code sections 321.5 and 321.171.

[ARC 6287C, IAB 4/6/22, effective 5/11/22]

**761—400.64(321) County treasurer's report of motor vehicle collections and funds.** The county treasurer shall file the report provided for in Iowa Code section 321.153 in a manner prescribed by the department.

This rule is intended to implement Iowa Code section 321.153.

**761—400.65 to 400.69** Reserved.

**761—400.70(321) Removal of registration and plates by peace officer under financial liability coverage law.** This rule applies to instances when a peace officer issues a citation and removes the registration receipt and

registration plates of a motor vehicle registered in this state when the driver of the motor vehicle is unable to provide proof of financial liability coverage. This rule applies regardless of whether the vehicle was also impounded.

**400.70(1)** The peace officer shall forward the registration receipt and evidence of the violation to the county treasurer of the county in which the motor vehicle is registered. Evidence of the violation is one of the following:

*a.* A copy of the citation. The citation must either reference Iowa Code subparagraph 321.20B(4)“a”(3) or 321.20B(4)“a”(4), as applicable, or reference Iowa Code section 321.20B and indicate whether or not the vehicle was impounded.

*b.* A written statement from the peace officer listing the plate number of the registration plate removed from the vehicle and the vehicle owner’s name. The statement must either reference Iowa Code subparagraph 321.20B(4)“a”(3) or 321.20B(4)“a”(4), as applicable, or reference Iowa Code section 321.20B and indicate whether or not the vehicle was impounded. The statement must be signed by the peace officer or an employee of the law enforcement agency.

**400.70(2)** The peace officer may either destroy removed plates or deliver the removed plates to the county treasurer for destruction.

This rule is intended to implement Iowa Code section 321.20B.

**761—400.71(321) Lemon law designation.** Rescinded IAB 11/7/07, effective 12/12/07.

**761—400.72(321) Electronic lien and title.**

**400.72(1)** The department may authorize the use of an electronic lien and title (ELT) system to provide an electronic record of the certificate of title to a security interest holder, to subject a vehicle to an electronic lien, and to allow for the submission and receipt of forms related to security interests through electronic means.

*a.* The department shall authorize ELT providers for transmission of vehicle data, title data and forms necessary to process security interest transactions through electronic means. The department may establish application forms and approval processes as necessary for ELT providers.

*b.* The department may authorize an ELT lender to participate in the ELT system if the ELT lender has first established a service relationship with an authorized ELT provider. The department may establish application forms and approval processes as necessary for ELT lenders.

**400.72(2)** For each individual transaction, an authorized ELT lender may choose to use either the ELT process or the paper security interest process as provided in Iowa Code section 321.50 and rules 761—400.8(321) and 761—400.10(321).

**400.72(3)** If a security interest is released through ELT and there are no other secured parties, but the ELT lender does not request a paper title to be printed and provided to the owner, or the ELT lender does not otherwise provide a paper title to the owner, then the owner of the vehicle may apply to the county treasurer or the department for a certificate of title to be printed and provided to the owner by submitting an application form in the form and manner prescribed by the department.

*a.* If there is more than one owner of the vehicle, any owner may apply to the department or the county treasurer, as applicable, for the certificate of title to be printed and provided to whomever the owner specifies.

*b.* If an owner is deceased, the signatures and documents specified in subrules 400.14(4) and 400.14(5) shall be required. A person entitled to vehicle ownership under the laws of descent and distribution shall sign the required forms and shall insert the words “heir at law” following the signature on the application form.

This rule is intended to implement Iowa Code section 321.50.

[ARC 6287C, IAB 4/6/22, effective 5/11/22]

[761—Chapter 400 appeared as Ch 11, Department of Public Safety, 1973 IDR]

[Filed 7/1/75]

[Filed 11/9/77, Notice 9/21/77—published 11/30/77, effective 1/4/78]

[Filed 5/9/78, Notice 3/22/78—published 5/31/78, effective 7/5/78]

[Filed 10/10/78, Notice 8/23/78—published 11/1/78, effective 12/6/78]

[Filed 11/13/78, Notice 9/20/78—published 11/29/78, effective 1/3/79]

[Filed 4/23/79, Notice 3/7/79—published 5/16/79, effective 6/20/79]

[Filed 8/23/79, Notice 7/11/79—published 9/19/79, effective 10/24/79]

[Filed 8/23/79, Notice 7/11/79—published 9/19/79, effective 12/1/79]

[Filed 2/14/80, Notice 12/26/79—published 3/5/80, effective 4/9/80]

[Filed 12/4/80, Notice 10/15/80—published 12/24/80, effective 1/28/81]

[Filed 12/16/81, Notice 10/28/81—published 1/6/82, effective 2/10/82]

[Filed 9/30/82, Notice 8/18/82—published 10/27/82, effective 12/1/82]  
[Filed 1/21/83, Notice 12/8/82—published 2/16/83, effective 3/23/83]  
[Filed emergency 2/17/83—published 3/16/83, effective 3/23/83]  
[Filed 8/4/83, Notice 6/22/83—published 8/31/83, effective 12/1/83]  
[Filed 12/23/83, Notice 11/9/83—published 1/18/84, effective 2/22/84]  
[Filed emergency 7/17/84—published 8/15/84, effective 7/18/84]  
[Filed 9/28/84, Notice 8/15/84—published 10/24/84, effective 11/28/84]  
[Filed emergency 12/6/84—published 1/2/85, effective 12/7/84]  
[Filed 1/9/85, Notice 11/21/84—published 1/30/85, effective 3/6/85]  
[Filed 7/10/85, Notice 5/22/85—published 7/31/85, effective 9/4/85]  
[Filed emergency 9/4/85—published 9/25/85, effective 10/1/85]  
[Filed 11/14/85, Notice 9/25/85—published 12/4/85, effective 1/8/86]  
[Filed emergency 10/9/86—published 11/5/86, effective 10/10/86]  
[Filed 12/18/86, Notice 11/5/86—published 1/14/87, effective 2/18/87]  
[Filed emergency 2/18/87—published 3/11/87, effective 2/18/87]  
[Filed 5/11/87, Notice 3/11/87—published 6/3/87, effective 7/8/87]<sup>o</sup>  
[Filed 11/5/87, Notice 9/23/87—published 12/2/87, effective 1/6/88]  
[Filed 1/6/88, Notice 11/18/87—published 1/27/88, effective 3/2/88]  
[Filed emergency 6/22/88—published 7/13/88, effective 7/1/88]  
[Filed 2/9/89, Notice 12/28/88—published 3/8/89, effective 4/12/89]  
[Filed 10/5/89, Notice 8/23/89—published 11/1/89, effective 12/6/89]  
[Filed 11/1/89, Notice 9/20/89—published 11/29/89, effective 1/3/90]  
[Filed emergency 11/30/89—published 12/27/89, effective 12/1/89]  
[Filed 2/7/90, Notice 12/27/89—published 3/7/90, effective 4/11/90]  
[Filed emergency 7/5/90—published 7/25/90, effective 7/5/90]  
[Filed 12/5/90, Notice 10/17/90—published 12/26/90, effective 1/30/91]  
[Filed 7/17/91, Notice 5/1/91—published 8/7/91, effective 9/11/91]  
[Filed 10/23/91, Notice 9/18/91—published 11/13/91, effective 12/18/91]  
[Filed 11/6/91, Notice 10/2/91—published 11/27/91, effective 1/1/92]  
[Filed 11/22/91, Notice 10/16/91—published 12/11/91, effective 1/15/92]<sup>o</sup>  
[Filed 1/15/92, Notice 12/11/91—published 2/5/92, effective 3/11/92]  
[Filed emergency 3/26/92—published 4/15/92, effective 4/29/92]  
[Filed 12/18/92, Notice 10/28/92—published 1/6/93, effective 2/10/93]  
[Filed 1/14/93, Notice 12/9/92—published 2/3/93, effective 3/10/93]  
[Filed 12/16/93, Notice 11/10/93—published 1/5/94, effective 2/9/94]  
[Filed 2/8/95, Notice 1/4/95—published 3/1/95, effective 4/5/95]  
[Filed 11/29/95, Notice 10/25/95—published 12/20/95, effective 1/24/96]  
[Filed 3/5/97, Notice 1/29/97—published 3/26/97, effective 4/30/97]  
[Filed 3/11/98, Notice 1/28/98—published 4/8/98, effective 5/13/98]  
[Filed 10/28/98, Notice 8/26/98—published 11/18/98, effective 12/23/98]  
[Filed 12/16/98, Notice 11/4/98—published 1/13/99, effective 2/17/99]  
[Filed 3/10/99, Notice 1/13/99—published 4/7/99, effective 5/12/99]  
[Filed 5/12/99, Notice 3/24/99—published 6/2/99, effective 7/7/99]  
[Filed 8/4/99, Notice 6/30/99—published 8/25/99, effective 9/29/99]  
[Filed 10/14/99, Notice 9/8/99—published 11/3/99, effective 12/8/99]<sup>o</sup>  
[Filed 5/3/00, Notice 2/23/00—published 5/31/00, effective 7/5/00]  
[Filed 7/18/01, Notice 5/30/01—published 8/8/01, effective 9/12/01]  
[Filed 1/17/02, Notice 11/28/01—published 2/6/02, effective 3/13/02]  
[Filed 6/19/02, Notice 4/17/02—published 7/10/02, effective 8/14/02]  
[Filed 11/7/02, Notice 10/2/02—published 11/27/02, effective 1/1/03]  
[Filed 11/2/05, Notice 9/14/05—published 11/23/05, effective 12/28/05]  
[Filed 10/11/07, Notice 8/15/07—published 11/7/07, effective 12/12/07]  
[Filed ARC 9048B (Notice ARC 8869B, IAB 6/30/10), IAB 9/8/10, effective 10/13/10]

[Filed ARC 9833B (Notice ARC 9742B, IAB 9/7/11), IAB 11/2/11, effective 12/7/11]  
[Filed ARC 0136C (Notice ARC 0068C, IAB 4/4/12), IAB 5/30/12, effective 7/4/12]  
[Filed ARC 2887C (Notice ARC 2780C, IAB 10/26/16), IAB 1/4/17, effective 2/8/17]  
[Filed ARC 2985C (Notice ARC 2908C, IAB 1/18/17), IAB 3/15/17, effective 4/19/17]  
[Filed ARC 3449C (Notice ARC 3306C, IAB 9/13/17), IAB 11/8/17, effective 12/13/17]  
[Filed ARC 3999C (Notice ARC 3890C, IAB 7/18/18), IAB 9/12/18, effective 10/17/18]  
[Filed ARC 4343C (Notice ARC 4230C, IAB 1/16/19), IAB 3/13/19, effective 4/17/19]  
[Filed ARC 4758C (Notice ARC 4625C, IAB 8/28/19), IAB 11/6/19, effective 12/11/19]  
[Filed ARC 4960C (Notice ARC 4770C, IAB 11/20/19), IAB 3/11/20, effective 4/15/20]  
[Filed ARC 5178C (Notice ARC 5080C, IAB 7/15/20), IAB 9/9/20, effective 10/14/20]  
[Filed ARC 5829C (Notice ARC 5618C, IAB 5/19/21), IAB 8/11/21, effective 9/15/21]  
[Filed ARC 5893C (Notice ARC 5621C, IAB 5/19/21), IAB 9/8/21, effective 10/13/21]  
[Filed ARC 6219C (Notice ARC 6118C, IAB 12/29/21), IAB 3/9/22, effective 4/13/22]  
[Filed ARC 6220C (Notice ARC 6066C, IAB 12/1/21), IAB 3/9/22, effective 4/13/22]  
[Filed ARC 6287C (Notice ARC 6175C, IAB 2/9/22), IAB 4/6/22, effective 5/11/22]  
[Filed ARC 6489C (Notice ARC 6361C, IAB 6/15/22), IAB 9/7/22, effective 10/12/22]  
[Filed ARC 6932C (Notice ARC 6770C, IAB 12/28/22), IAB 3/8/23, effective 4/12/23]

◊ Two or more ARCs



CHAPTER 401  
SPECIAL REGISTRATION PLATES

**761—401.1(321) Definition.** “Special registration plates” means those registration plates issued under Iowa Code sections 321.34 and 321.105 other than regular or sample plates. Special registration plates shall be issued in accordance with Iowa Code sections 321.34 and 321.105, this chapter of rules, and other applicable provisions of law.

**761—401.2(321) Application, issuance and renewal.**

**401.2(1) Original application.**

*a.* Except for collegiate plates, application for letter-number designated special registration plates that do not have eligibility requirements shall be made directly to the county treasurer’s office; no application form is required for these plates.

*b.* Application for blackout plates, collegiate plates, flying our colors plates, personalized plates, and special registration plates that have eligibility requirements must be submitted to the department in a manner prescribed by the department. Unless otherwise specified, completed applications for these plates shall be submitted to the department at the following address: Vehicle and Motor Carrier Services Bureau, Iowa Department of Transportation, P.O. Box 9278, Des Moines, Iowa 50306-9278. Applications may be obtained from the vehicle and motor carrier services bureau or from any county treasurer’s office. Applications are also available on the department’s website at [www.iowadot.gov](http://www.iowadot.gov).

*c.* The issuance fee, if any, shall be submitted with the application.

**401.2(2) Issuance.**

*a.* Special registration plates shall be issued only to a person who is an owner or lessee of the vehicle and is entitled to the special registration plates.

*b.* Special registration plates shall not be issued unless the vehicle is currently registered and the registration plates previously issued are surrendered to the county treasurer. Special registration plates are void if they are not assigned to a vehicle within 90 days after the date the department orders them. A new application and a new issuance fee are required if the plates are reordered after the 90-day period.

*c. and d.* Rescinded IAB 11/7/07, effective 12/12/07.

**401.2(3) Renewal.** Special registration plates are renewed at the office of the county treasurer of the county of residence of the applicant. The renewal fee, if any, is termed a “validation” fee. The validation fee shall be paid when the regular annual registration fee is due and is in addition to the regular annual registration fee. If renewal is delinquent for more than one month:

*a.* A new application and a new issuance fee are required.

*b.* The department may issue the combination of characters on personalized plates to another applicant.

**401.2(4) Fees.** The issuance and validation fees for the various types of special registration plates that are available are set out in Iowa Code section 321.34.

[ARC 9048B, IAB 9/8/10, effective 10/13/10; ARC 3935C, IAB 8/1/18, effective 9/5/18; ARC 4908C, IAB 2/12/20, effective 3/18/20; ARC 5344C, IAB 12/30/20, effective 2/3/21]

**761—401.3** Reserved.

**761—401.4(321) Gift certificates.** Gift certificates for blackout plates, collegiate plates, flying our colors plates, personalized plates, and special registration plates that have eligibility requirements may be purchased using the prescribed plate application. Gift certificates for special registration plates that counties have in their inventories may be purchased from county treasurers’ offices.

[ARC 4908C, IAB 2/12/20, effective 3/18/20; ARC 5344C, IAB 12/30/20, effective 2/3/21]

**761—401.5(321) Amateur radio call letter plates.** Application for amateur radio call letter plates shall be made to the county treasurer in a manner prescribed by the department. The number of the amateur radio license issued by the Federal Communications Commission shall be listed on the application.

[ARC 4908C, IAB 2/12/20, effective 3/18/20]

**761—401.6(321) Personalized plates.**

**401.6(1) Application.** Application for personalized plates shall be submitted to the department in a manner prescribed by the department.

**401.6(2) Characters.** The personalized plates shall consist of no fewer than two nor more than seven characters except that personalized plates for motorcycles, autocycles and small trailers shall consist of no fewer than two nor more than six characters.

- a. The characters "A" to "Z" and "0" to "9" may be used.
- b. The personalized plates shall not duplicate combinations of characters reserved or issued for any other vehicle plate series under Iowa Code chapter 321.
- c. No combination of characters denoting a governmental agency shall be issued.
- d. The department shall not issue any combination of characters it determines is:
  - (1) Sexual in connotation;
  - (2) A term of vulgarity, contempt, prejudice, hostility, insult, or racial or ethnic degradation;
  - (3) Recognized as a swear word;
  - (4) A reference to an illegal substance;
  - (5) A reference to a criminal act;
  - (6) Offensive; or
  - (7) A foreign word falling into any of these categories.

**401.6(3) Renewal.** Rescinded IAB 11/23/05, effective 12/28/05.

**401.6(4) Reassignment.** Rescinded IAB 11/23/05, effective 12/28/05.

**401.6(5) Gift certificate.** Rescinded IAB 11/23/05, effective 12/28/05.

[ARC 2985C, IAB 3/15/17, effective 4/19/17; ARC 4908C, IAB 2/12/20, effective 3/18/20; ARC 5344C, IAB 12/30/20, effective 2/3/21]

#### **761—401.7(321) Collegiate plates.**

**401.7(1) Application.** Application for collegiate plates shall be submitted to the department in a manner prescribed by the department. The applicant may request letter-number designated collegiate plates or personalized collegiate plates. Collegiate plates for motorcycles, autocycles and small trailers are not available.

**401.7(2) Characters.** Personalized collegiate plates shall be issued in accordance with subrule 401.6(2) except that personalized collegiate plates are not available for motorcycles, autocycles and small trailers.

**401.7(3) Renewal.** Rescinded IAB 11/23/05, effective 12/28/05.

**401.7(4) Reassignment.** Rescinded IAB 11/23/05, effective 12/28/05.

**401.7(5) Gift certificate.** Rescinded IAB 11/23/05, effective 12/28/05.

[ARC 2985C, IAB 3/15/17, effective 4/19/17; ARC 4908C, IAB 2/12/20, effective 3/18/20]

#### **761—401.8(321) Medal of Honor plates.**

**401.8(1)** Application for Medal of Honor plates shall be submitted to the department in a manner prescribed by the department. The applicant shall attach a copy of the official government document verifying receipt of the medal of honor.

**401.8(2)** Medal of Honor plates are limited to five characters. Personalized plates are not available.

[ARC 4908C, IAB 2/12/20, effective 3/18/20]

#### **761—401.9(321) Firefighter plates.**

**401.9(1) Initial application for firefighter plates.** Application for firefighter plates shall be submitted to the department in a manner prescribed by the department. Both the fire chief and another fire officer of the paid or volunteer fire department shall sign the application, certifying that the applicant is a current or retired member of the fire department. If the fire chief and fire officer deny an application, the department may conduct an investigation and make a determination to approve or deny the application.

**401.9(2) Renewal of firefighter plates for a current member.** A new application is required in order to renew firefighter plates issued to a current member. The application shall be submitted to the county treasurer's office.

**401.9(3) Renewal of firefighter plates for a retired member.**

a. A new application is not required in order to renew firefighter plates issued to a retired member if the initial application for firefighter plates is made after January 1, 2005.

b. For firefighter plates issued to a retired member prior to January 1, 2005, a new application is required in order to renew firefighter plates until the plates have been renewed once after January 1, 2005. The application shall be submitted to the county treasurer's office.

**401.9(4) Plates.** Firefighter plates are limited to five characters. Personalized plates are not available. When a new series of firefighter plates is issued to replace a current series or the plate has been lost, stolen, or damaged, an applicant may obtain replacement plates containing the applicant's previous plate number upon payment of the statutory fee.

**401.9(5) Definitions.** The following definitions apply to this rule:

“*Current*” means a member who has at least one year of service and is in good standing, as determined by the fire chief.

“*Fire officer*” means a member of the same fire department as the applicant and who is second in command to the fire chief.

“*Retired*” or “*officially retired*” means a former member who has a minimum of ten years’ total service in good standing, as determined by the fire chief.

[ARC 0778C, IAB 6/12/13, effective 7/17/13; ARC 4344C, IAB 3/13/19, effective 4/17/19]

#### **761—401.10(321) Emergency medical services plates.**

**401.10(1)** Application for emergency medical services (EMS) plates shall be submitted to the department in a manner prescribed by the department. The applicant and the applicant’s service director shall sign the application certifying that the applicant is a current member of a paid or volunteer emergency medical services agency. For purposes of this subrule, “service director” means a service director as defined in Iowa department of public health rule 641—132.1(147A).

**401.10(2)** A vehicle owner whose membership in a paid or volunteer emergency medical services agency is terminated shall within 30 days after termination surrender the EMS plates to the county treasurer in exchange for regular registration plates.

**401.10(3)** EMS plates are limited to five characters. Personalized plates are not available. When a new series of EMS plates is issued to replace a current series or the plate has been lost, stolen, or damaged, an applicant may obtain replacement plates containing the applicant’s previous plate number upon payment of the statutory fee.

[ARC 0136C, IAB 5/30/12, effective 7/4/12; ARC 0778C, IAB 6/12/13, effective 7/17/13; ARC 3935C, IAB 8/1/18, effective 9/5/18; ARC 4908C, IAB 2/12/20, effective 3/18/20]

**761—401.11(321) Natural resources plates.** Letter-number designated natural resources plates are limited to five characters. Personalized natural resources plates shall consist of no less than two nor more than five characters and shall be issued in accordance with subrule 401.6(2), paragraphs “a” to “d.”

#### **761—401.12(321) Blackout plates.**

**401.12(1) Application.** Application for blackout plates shall be submitted to the department in a manner prescribed by the department. The applicant may request letter-number designated blackout plates or personalized blackout plates. Blackout plates are available for autocycles, motor trucks, motor homes, multipurpose vehicles, motorcycles, trailers and travel trailers.

**401.12(2) Characters.** Personalized blackout plates shall be issued in accordance with subrule 401.6(2).

[ARC 4908C, IAB 2/12/20, effective 3/18/20]

#### **761—401.13(321) Disabled veteran plates.**

**401.13(1)** Disabled veteran plates are issued in accordance with Iowa Code sections 321.34, 321.105 and 321.166.

**401.13(2)** To apply for disabled veteran plates for a motor vehicle, the disabled veteran shall submit to the county treasurer a certification from the U.S. Department of Veterans Affairs that the United States government has provided or has assisted in providing the motor vehicle to the disabled veteran. The certification is required when the motor vehicle is first registered. Another certification may be required for the first registration of a newly acquired vehicle or when the veteran moves to another county.

**401.13(3)** The disabled veteran plates shall be surrendered to the county treasurer in exchange for regular registration plates within 30 days after the death of the disabled veteran. The motor vehicle to which the plates are assigned shall become subject to the payment of regular registration fees on the first day of the month following the death of the disabled veteran. The registration fees shall be prorated for the remaining unexpired months of the registration year.

#### **761—401.14(321) Flying our colors plates.**

**401.14(1) Application.** Application for flying our colors plates shall be submitted to the department in a manner prescribed by the department. The applicant may request letter-number designated flying our colors plates or personalized flying our colors plates. Flying our colors plates are available for autocycles, motor trucks, motor homes, multipurpose vehicles, motorcycles, trailers and travel trailers.

**401.14(2) Characters.** Personalized flying our colors plates shall be issued in accordance with subrule 401.6(2).

[ARC 5344C, IAB 12/30/20, effective 2/3/21]

**761—401.15(17A,321) Nonprofit organization decal.** The following shall apply to all applications for an organization decal under Iowa Code section 321.34(13).

**401.15(1)** Application to request a new decal shall be submitted to the department on Form 411346. The application shall be subject to the requirements in Iowa Code section 321.34(13) and shall include all of the information and documentation required by Iowa Code section 321.34(13)“c.” An organization applying for approval of a decal shall meet the criteria set forth in Iowa Code section 321.34(13)“b”(1). A group of organizations applying for approval of a decal must have a common purpose as required by Iowa Code section 321.34(13)“b”(2), and each organization within the group must meet the criteria set forth in Iowa Code section 321.34(13)“b”(1).

**401.15(2)** The proposed decal shall be designed to be placed in the space reserved for the placement of an organization decal and shall be limited to dimensions of 2.875" in width and 3" in height. As required by Iowa Code section 321.34(13)“d,” the proposed decal design shall not:

- a. Promote a specific religion, faith or anti-religious sentiment.
- b. Have any sexual connotation.
- c. Be vulgar, prejudiced, hostile, insulting, or racially or ethnically degrading.

**401.15(3)** The vehicle and motor carrier services bureau may consult with other organizations, law enforcement authorities, and the general public concerning the decal design.

**401.15(4)** Within 60 days after receiving the application, the vehicle and motor carrier services bureau shall advise the organization of the department’s approval or denial of the application. The department reserves the right to approve or disapprove any decal design.

**401.15(5)** If the decal is approved and at a later date it is determined that a false application was submitted, or a violation of Iowa Code section 321.34(13) or this chapter occurred, the department shall revoke the decal and the organization shall no longer issue the decal.

**401.15(6)** If the department denies or revokes the decal design, the department shall send notice of the denial or revocation by certified mail to the organization at the address listed on the application. The revocation or denial shall become effective 20 days from the date of mailing. The organization may contest the decision of the department in accordance with 761—Chapter 13. The request shall be deemed timely if it is delivered or postmarked on or before the effective date specified in the notice.

[ARC 9048B, IAB 9/8/10, effective 10/13/10; ARC 3935C, IAB 8/1/18, effective 9/5/18; ARC 4908C, IAB 2/12/20, effective 3/18/20]

**761—401.16(17A,321) Special plates with space reserved for a nonprofit organization decal.**

**401.16(1)** Application for special plates with space reserved for an organization decal shall be subject to the requirements in Iowa Code section 321.34(13).

**401.16(2)** A person shall obtain the decal to display on the special registration plate from an organization approved by the department. A person shall not display a decal on a vehicle registration plate other than a decal approved by the department. An approved decal shall only be affixed to and displayed in the space reserved for placement of the organization decal on the registration plate.

**401.16(3)** Personalized special plates with space reserved for an organization decal shall be limited to no more than five initials, letters, or combinations of numerals and letters.

[ARC 3935C, IAB 8/1/18, effective 9/5/18]

**761—401.17(321) State agency-sponsored processed emblem plates.** Rescinded ARC 3935C, IAB 8/1/18, effective 9/5/18.

**761—401.18(321) Combat infantryman badge, combat action badge, combat action ribbon, air force combat action medal, combat medical badge, fallen peace officers and civil war sesquicentennial plates.** Following is the application and approval process for special plate requests under Iowa Code section 321.34(20C).

**401.18(1) Design.**

a. The plates shall be a standard background plate with a distinguishing processed emblem specific to each plate type.

b. The distinguishing processed emblem shall be limited to 2.875" × 3" on the registration plate.

c. A distinguishing processed emblem owned or subject to legal rights of another person will not be used unless the department receives certification from the person that allows use of the emblem. The certification must include a statement holding the department harmless for using the emblem on a registration plate.

d. The vehicle and motor carrier services bureau may consult with other organizations, law enforcement authorities, and the general public concerning distinguishing processed emblems.

**401.18(2) Production.** None of the special registration plates subject to this rule will be manufactured or issued until 250 paid applications are submitted to the department. This minimum order requirement applies to each of the special registration plates subject to this rule. Each application must be accompanied by a statutory start-up fee.

**401.18(3) Discontinuance.** If 250 paid applications for any special registration plate subject to this rule are not submitted within one year after the date the department makes the plate available for application, the department shall report that fact to the legislature at the next regular session of the general assembly and request authority to discontinue the special registration plate.

**401.18(4) Application process.**

*a.* Applications for either letter-number designated or personalized combat infantryman badge, combat action badge, combat action ribbon, air force combat action medal, or combat medical badge special registration plates shall be submitted to the department in a manner prescribed by the department. The applicant shall attach to the application a copy of an official government document verifying award of the combat infantryman badge, combat action badge, combat action ribbon, air force combat action medal or combat medical badge to the applicant.

*b.* Applications for letter-number designated civil war sesquicentennial or fallen peace officers special registration plates shall be submitted to the county treasurer.

*c.* Applications for personalized civil war sesquicentennial or fallen peace officers special registration plates shall be submitted to the department in a manner prescribed by the department.

**401.18(5) Characters.** Plates are limited to five characters. Personalized plates shall consist of no less than two nor more than five characters and shall be issued in accordance with subrule 401.6(2), paragraphs “a” to “d.”

**401.18(6) Right of approval.** The department reserves the right to approve or disapprove any application.

[ARC 9833B, IAB 11/2/11, effective 12/7/11; ARC 3935C, IAB 8/1/18, effective 9/5/18; ARC 4908C, IAB 2/12/20, effective 3/18/20]

**761—401.19(321) Legion of Merit plates.** Application for special plates with a Legion of Merit processed emblem shall be submitted to the department in a manner prescribed by the department. The applicant shall attach a copy of the official government document verifying receipt of the Legion of Merit. Personalized plates with a Legion of Merit processed emblem are not available. Pursuant to Iowa Code section 321.34, an applicant is eligible for one set of Legion of Merit plates at a reduced annual registration fee of \$15 for one vehicle owned. However, an applicant may obtain additional Legion of Merit plates upon payment of the regular annual registration fee.

[ARC 9048B, IAB 9/8/10, effective 10/13/10; ARC 4908C, IAB 2/12/20, effective 3/18/20]

**761—401.20(321) Persons with disabilities plates.**

**401.20(1) Application.** Application for special plates with a persons with disabilities processed emblem shall be submitted to the county treasurer in a manner prescribed by the department.

*a.* The application shall comply with the requirements of 761—subrule 411.3(2) and shall certify that the owner or the owner’s child is a person with a disability, as defined in Iowa Code section 321L.1, and that the disability is permanent.

*b.* If the person with a disability is a child, the parent or guardian shall complete the proof of residency certification on the application or complete and submit a separate proof of residency Form 411120, certifying that the child resides with the owner.

*c.* In lieu of submitting the statement of disability required in 761—subrule 411.3(2), an individual who is eligible for disabled veteran plates but has not been issued them may submit certification from the U.S. Department of Veterans Affairs that the United States government has provided or assisted in providing a motor vehicle to the individual.

**401.20(2) Definition.**

“Child” includes, but is not limited to, stepchild, foster child, or legally adopted child who is younger than 18 years of age, or a dependent person 18 years of age or older who is unable to maintain the person’s self.

**401.20(3) Renewal.** The owner shall, at renewal time, submit a persons with disabilities parking permit application pursuant to rule 761—411.3(321L) that includes all required documentation and shows the owner or the owner’s child remains permanently disabled and has a continuing need for the plates.

[ARC 0136C, IAB 5/30/12, effective 7/4/12; ARC 3450C, IAB 11/8/17, effective 12/13/17; ARC 4908C, IAB 2/12/20, effective 3/18/20]

**761—401.21(321) Ex-prisoner of war plates.**

**401.21(1)** Application for special plates with an ex-prisoner of war processed emblem shall be submitted to the department in a manner prescribed by the department. The applicant shall attach a copy of an official government document verifying that the applicant was a prisoner of war. If the document is not available, a person who has knowledge that the applicant was a prisoner of war shall sign a statement to that effect on the application .

**401.21(2)** The surviving spouse of a person who was issued ex-prisoner of war plates may continue to use or apply for the plates. If the surviving spouse remarries, the surviving spouse shall surrender the plates to the county treasurer in exchange for regular registration plates within 30 days after the date on the marriage certificate. Ex-prisoner of war plates may not be reissued once this event occurs.

**401.21(3)** Personalized plates with an ex-prisoner of war processed emblem are not available.

[ARC 4908C, IAB 2/12/20, effective 3/18/20]

**761—401.22(321) National guard plates.** Application for special plates with a national guard processed emblem shall be submitted to the department in a manner prescribed by the department. The unit commander of the applicant shall sign the application confirming that the applicant is a member of the Iowa national guard.

[ARC 4908C, IAB 2/12/20, effective 3/18/20]

**761—401.23(321) Pearl Harbor plates.** Application for special plates with a Pearl Harbor processed emblem shall be submitted to the department in a manner prescribed by the department. The applicant shall attach a copy of an official government document verifying that the applicant was stationed at Pearl Harbor, Hawaii, as a member of the armed forces on December 7, 1941.

[ARC 4908C, IAB 2/12/20, effective 3/18/20]

**761—401.24(321) Purple Heart, Silver Star and Bronze Star plates.** Application for special plates with a Purple Heart, Silver Star, or Bronze Star processed emblem shall be submitted to the department in a manner prescribed by the department. To verify receipt of the medal, the applicant shall attach a copy of one of the following:

1. The official military order confirming the medal.
2. The report of discharge or federal Form DD214.
3. Other documentation approved by the Iowa office of the adjutant general.

[ARC 4908C, IAB 2/12/20, effective 3/18/20]

**761—401.25(321) U.S. armed forces retired plates.** Application for special plates with a United States armed forces retired processed emblem shall be submitted to the department in a manner prescribed by the department. A person is considered to be retired if the person is recognized by the United States armed forces as retired from the United States armed forces. To verify retirement from the United States armed forces, the applicant shall attach a copy of one of the following:

1. The official military order confirming retirement from the armed forces.
2. The report of discharge or federal Form DD214.
3. Other documentation approved by the Iowa office of the adjutant general.

[ARC 4908C, IAB 2/12/20, effective 3/18/20]

**761—401.26** Reserved.

**761—401.27(321) Iowa heritage plates.** Rescinded IAB 11/23/05, effective 12/28/05.

**761—401.28(321) Education plates.** Rescinded IAB 11/23/05, effective 12/28/05.

**761—401.29(321) Love our kids plates.** Rescinded IAB 11/23/05, effective 12/28/05.

**761—401.30(321) Motorcycle rider education plates.** Rescinded IAB 11/23/05, effective 12/28/05.

**761—401.31(321) Veteran plates.** Application for special plates with a veteran processed emblem shall be submitted to the commission of veterans affairs on a form prescribed by the department of transportation. The commission of veterans affairs shall determine whether the applicant is a veteran and, if so, certify this fact on the application form.

**761—401.32(321) Surrender of plates.** Special registration plates issued to a person who is no longer eligible for the plates shall be surrendered to the county treasurer in exchange for regular registration plates within 30 days after the date of the event that made the person ineligible. If the vehicle was exempt from the payment of regular registration fees due to the type of special registration plates issued, the vehicle shall become subject to the payment of regular registration fees on the first day of the month following the date of the event that made the person ineligible. The regular registration fees shall be prorated for the remaining unexpired months of the registration year.

**761—401.33(321) Validation fees.** Validation fees shall not be prorated. The annual validation fee is due when there is a change in registration month.

**761—401.34(321) Reassignment of plates.**

**401.34(1)** A vehicle owner or lessee who has special registration plates assigned to a currently registered vehicle may request that the plates be reassigned to another currently registered vehicle owned or leased by that person or owned or leased by another person. However, special registration plates that have eligibility requirements may not be reassigned to a vehicle owned or leased by another person.

**401.34(2)** To reassign plates to a vehicle owned or leased by another person, a written request for reassignment signed by both the assignor and assignee shall be submitted to the county treasurer of the assignee's county of residence. The special registration plates shall be issued to the assignee by the county treasurer of the assignee's county of residence in exchange for the registration plates previously issued.

**401.34(3)** When ownership of a vehicle is transferred to another person, the owner shall, within 30 days after the transfer, either surrender the special registration plates to the county treasurer or request reassignment of the plates, as explained in subrules 401.34(1) and 401.34(2).

**401.34(4)** When the lease for a vehicle is terminated, the lessee shall, within 30 days after the termination, either surrender the special registration plates to the county treasurer or request reassignment of the plates, as explained in subrules 401.34(1) and 401.34(2).

**761—401.35(321) Revocation of special registration plates—appeal.**

**401.35(1)** Special registration plates shall be revoked if they have been issued in conflict with the statutes or rules governing the plates' issuance. Revoked plates shall be surrendered to the department within 30 days of the date of revocation.

**401.35(2)** The department shall send the notice of revocation to a person's mailing address by certified mail, and the revocation shall become effective 20 days from the date of mailing. The person may contest the decision of the department in accordance with 761—Chapter 13. The request shall be deemed timely if it is delivered or postmarked on or before the effective date specified in the notice.

[ARC 3935C, IAB 8/1/18, effective 9/5/18]

**761—401.36(321) Refund of fees.** No refund of fees for special registration plates shall be allowed unless the special plates were issued in conflict with the statutes or rules governing their issuance.

These rules are intended to implement Iowa Code sections 35A.11; 321.34 as amended by 2020 Iowa Acts, House File 2641, section 155; 321.105; 321.166 as amended by 2020 Iowa Acts, House File 2641, section 156; and 321L.1 and chapter 17A.

[Filed 2/8/95, Notice 1/4/95—published 3/1/95, effective 4/5/95]

[Filed 11/25/97, Notice 10/8/97—published 12/17/97, effective 1/21/98]

[Filed 12/16/98, Notice 11/4/98—published 1/13/99, effective 2/17/99]

[Filed 3/10/99, Notice 1/13/99—published 4/7/99, effective 5/12/99]

[Filed 10/14/99, Notice 9/8/99—published 11/3/99, effective 12/8/99]

[Filed 6/19/02, Notice 4/17/02—published 7/10/02, effective 8/14/02]

[Filed 7/13/04, Notice 5/12/04—published 8/4/04, effective 9/8/04]

[Filed 11/2/05, Notice 9/14/05—published 11/23/05, effective 12/28/05]

[Filed 10/11/07, Notice 8/15/07—published 11/7/07, effective 12/12/07]

[Filed ARC 9048B (Notice ARC 8869B, IAB 6/30/10), IAB 9/8/10, effective 10/13/10]

[Filed ARC 9833B (Notice ARC 9742B, IAB 9/7/11), IAB 11/2/11, effective 12/7/11]

[Filed ARC 0136C (Notice ARC 0068C, IAB 4/4/12), IAB 5/30/12, effective 7/4/12]

[Filed ARC 0778C (Notice ARC 0658C, IAB 4/3/13), IAB 6/12/13, effective 7/17/13]

[Filed ARC 2985C (Notice ARC 2908C, IAB 1/18/17), IAB 3/15/17, effective 4/19/17]

[Filed ARC 3450C (Notice ARC 3304C, IAB 9/13/17), IAB 11/8/17, effective 12/13/17]

[Filed ARC 3935C (Notice ARC 3820C, IAB 6/6/18), IAB 8/1/18, effective 9/5/18]

[Filed ARC 4344C (Notice ARC 4232C, IAB 1/16/19), IAB 3/13/19, effective 4/17/19]

[Filed ARC 4908C (Notice ARC 4736C, IAB 11/6/19), IAB 2/12/20, effective 3/18/20]

[Filed ARC 5344C (Notice ARC 5232C, IAB 10/21/20), IAB 12/30/20, effective 2/3/21]



CHAPTERS 402 to 404  
Reserved



CHAPTER 405  
SALVAGE

**761—405.1(321) Applicability.** This chapter supplements 761—Chapter 400. It applies to salvage motor vehicles and foreign motor vehicles brought into Iowa that are or were salvage, rebuilt or junked. This chapter applies only to motor vehicles subject to registration except that owners of vehicles with a gross vehicle weight rating of 30,000 pounds or more are not required to submit a salvage theft examination to convert a salvage title to a regular title.

[ARC 5345C, IAB 12/30/20, effective 2/3/21]

**761—405.2(321,321H) Definitions.**

“*Authorized vehicle recycler*” means a person licensed under Iowa Code chapter 321H.

“*Foreign jurisdiction*” means a jurisdiction other than Iowa.

“*Iowa salvage title*” means an Iowa salvage certificate of title.

“*Junking certificate*” means an Iowa junking certificate.

“*New motor vehicle dealer*” means a dealer licensed under Iowa Code chapter 322 to sell new motor vehicles.

“*Previous owner*” as used in Iowa Code section 321.24 means the last titled owner.

“*Regular foreign title*” means a certificate of title issued by a foreign jurisdiction that allows the vehicle to be driven or moved upon a highway.

“*Regular Iowa title*” means an Iowa certificate of title that is not a salvage title.

“*Salvage theft examination certificate*” means a certificate, including an electronic certificate in the form and manner prescribed by the department, issued by a peace officer who has been specially certified to conduct salvage theft examinations as provided in Iowa Code section 321.52.

[ARC 5345C, IAB 12/30/20, effective 2/3/21; ARC 6220C, IAB 3/9/22, effective 4/13/22]

**761—405.3(321) Salvage title.**

**405.3(1) *Face of title.*** Except for vehicles with a gross vehicle weight rating of 30,000 pounds or more, the following shall be printed on the face of an Iowa salvage title: SALVAGE.

**405.3(2) *Assignment.*** An Iowa or a foreign salvage title may be assigned only as provided in Iowa Code subsection 321.52(4). Except as provided in subrule 405.3(3), the transferee to whom an Iowa or a foreign salvage title is assigned shall apply for a new Iowa salvage title within 30 days after the date of assignment unless, within this time period, application for a regular title is made or a junking certificate is obtained.

**405.3(3) *Reassignment.*** Reassignment of an Iowa or a foreign salvage title by a licensed new motor vehicle dealer or by an authorized vehicle recycler is allowed, and the dealer or recycler is not required to obtain a new Iowa salvage title upon assignment of an Iowa or a foreign salvage title to the dealer or recycler, provided a vacant reassignment space is available on the title. If all reassignment spaces on an Iowa or a foreign salvage title assigned to the dealer or recycler have been used, the dealer or recycler shall obtain a new Iowa salvage title in accordance with subrule 405.3(2). The following shall be printed on the dealer reassignment portion of Iowa salvage titles: ONLY NEW MOTOR VEHICLE DEALERS OR RECYCLERS MAY REASSIGN THIS TITLE.

**405.3(4) *Registration fees.***

*a.* An Iowa salvage title may be obtained without payment of the current registration fees or any delinquent registration fees or registration penalties. If the registration fees are delinquent at the time of issuance of an Iowa salvage title, no additional penalty shall accrue after issuance.

*b.* Any registration fees or registration penalties due at the time of issuance of an Iowa salvage title, together with the current registration fees if not already paid, shall be paid upon issuance of a regular title. However, a dealer is not required to pay current registration fees to obtain a regular title for a vehicle held for resale or trade. See rule 761—400.27(321,322) for any exceptions.

*c.* Notwithstanding any provision of this chapter to the contrary, an Iowa salvage title obtained by an insurer pursuant to the provisions under Iowa Code section 321.52(4) shall be issued free and clear of all liens and claims of ownership, including any outstanding registration fees or registration penalties.

**405.3(5) *Plates.*** Registration plates shall not be assigned when an Iowa salvage title is issued.

[ARC 9048B, IAB 9/8/10, effective 10/13/10; ARC 3999C, IAB 9/12/18, effective 10/17/18; ARC 5345C, IAB 12/30/20, effective 2/3/21]

**761—405.4 and 405.5** Reserved.

**761—405.6(321) Iowa salvage title required.**

**405.6(1) *Wrecked or salvage vehicle.*** A vehicle rebuilder or a person engaged in the business of buying, selling, or exchanging vehicles of a type required to be registered in this state upon acquisition of a wrecked or salvage vehicle shall obtain an Iowa salvage title or a junking certificate for the vehicle except as provided in subrule 405.3(3).

*a.* A wrecked or salvage vehicle is a damaged motor vehicle that:

(1) Has repair costs exceeding 70 percent of its fair market value before it became damaged, and

(2) Had a fair market value of \$500 or more before it became damaged.

*b.* Fair market value is the average retail value found in the National Automobile Dealers Association (NADA) Official Used Car Guide. If there is no value available, the motor vehicle division shall determine the fair market value upon request. The address is: Motor Vehicle Division, Iowa Department of Transportation, P.O. Box 9278, Des Moines, Iowa 50306-9278.

**405.6(2) *Insurer.*** An insurer upon acquisition of a motor vehicle as a result of a settlement with the motor vehicle owner arising out of damage to or unrecovered theft of the motor vehicle shall obtain an Iowa salvage title for the motor vehicle.

**405.6(3) *Application.*** Application for an Iowa salvage title shall be made within 30 days after the date of assignment to the transferee.

[ARC 5345C, IAB 12/30/20, effective 2/3/21; ARC 6220C, IAB 3/9/22, effective 4/13/22]

**761—405.7(321) Converting salvage title to regular title.**

**405.7(1) *General application procedure.***

*a.* To obtain a regular title, the owner in whose name the salvage title is issued or assigned shall pay the appropriate fees and surrender the salvage title when applying for the regular title.

*b.* To obtain a regular title, the applicant shall have completed a salvage theft examination certificate for the vehicle as required by Iowa Code section 321.52. However, a salvage theft examination certificate is not required if the vehicle has a gross vehicle weight rating of 30,000 pounds or more. See rule 761—405.15(321) for salvage theft examination.

*c.* A regular title and registration receipt issued pursuant to this subrule shall bear the designation “REBUILT-IA.”

**405.7(2) *Insurer’s certification.*** An insurer who has title pursuant to Iowa Code section 321.52(4) may submit an insurer’s certification in lieu of a salvage theft examination certificate.

*a.* The insurer’s certification shall:

(1) Include the name and address of the insurance company and the VIN, year and make of the salvage titled vehicle.

(2) Include a statement by the insurer certifying that the retail cost of repairs for all damages to the vehicle is less than \$3000.

(3) Be dated and signed by an authorized representative of the insurer.

*b.* The insurer’s certification is not transferable if the insurer assigns the salvage title to another person.

*c.* A regular title and registration receipt issued pursuant to this subrule is not required to have a designation of “REBUILT-IA.” However, the title and registration receipt shall bear any designation to be carried forward, as explained in rule 761—405.10(321).

[ARC 5345C, IAB 12/30/20, effective 2/3/21]

**761—405.8(321) Foreign vehicles.**

**405.8(1) *Definitions.*** The following definitions apply to foreign titles and the designations shown on them.

“*Junked*” means the vehicle is damaged or dismantled and is prohibited from ever again being driven upon a highway.

“*Rebuilt*” means the vehicle had been designated as salvage but had the designation removed, and the vehicle is permitted to be driven and moved upon a highway. Also, a designation of “salvage” on a regular foreign title means that the vehicle is rebuilt.

“*Salvage*” means the vehicle is damaged and shall not be registered to be driven or moved upon a highway until it is no longer designated as salvage.

**405.8(2) *Foreign title with rebuilt designation.*** If the prior title for a vehicle is a foreign title indicating that the vehicle was rebuilt, the Iowa title and registration receipt issued from the foreign title shall contain the designation of “rebuilt” together with the two-letter abbreviation of the name of the jurisdiction that issued the foreign title.

Exception:

If a records check indicates that the vehicle was previously titled in Iowa with a designation of “prior salvage,” the prior salvage designation shall be redesignated as “REBUILT-IA” and the “REBUILT-IA” designation takes precedence and shall be carried forward to the Iowa title and registration receipt. If a records check indicates that the vehicle was previously titled in Iowa with a designation of “REBUILT-IA,” the “REBUILT-IA” designation takes precedence and shall be carried forward to the Iowa title and registration receipt.

**405.8(3)** *Converting foreign salvage title to Iowa title.* If the prior title for a vehicle is a foreign title indicating that the vehicle is salvage, a regular Iowa title shall not be issued for the vehicle unless an Iowa salvage title is first issued. After an Iowa salvage title is issued for the vehicle, a regular Iowa title may be obtained pursuant to rule 761—405.7(321).

Exception 1:

As provided in 405.3(3), a licensed new motor vehicle dealer or an authorized vehicle recycler is not required to obtain an Iowa salvage title upon assignment of a foreign salvage title to the dealer or recycler, provided a vacant reassignment space is available on the title.

Exception 2:

As provided in Iowa Code section 321.24(5), an owner who surrenders a foreign salvage title and obtains a salvage theft examination pursuant to Iowa Code section 321.52(4) “b” within 30 days of the date the owner was assigned the foreign salvage title is not required to first obtain an Iowa salvage title.

**405.8(4)** *Salvage titled vehicle leaving and reentering Iowa.* If a vehicle leaves Iowa with an Iowa salvage title and reenters Iowa with a regular foreign title, a regular Iowa title may be issued without a salvage theft examination. The regular Iowa title and registration receipt issued from the foreign title will be designated:

- a. “REBUILT-IA” if the foreign title does not indicate that the vehicle was rebuilt.
- b. As specified in subrule 405.8(2) if the foreign title indicates that the vehicle was rebuilt.

**405.8(5)** *Designation carried forward.* If a vehicle leaves Iowa with a regular Iowa title and reenters Iowa with a regular foreign title and if the foreign title does not indicate that the vehicle was rebuilt and if a records check indicates that the vehicle had a designation listed in paragraphs 405.10(1) “a” through “f,” that designation shall be carried forward to the Iowa title and registration receipt issued from the foreign title.

**405.8(6)** *Foreign title with flood, fire, vandalism or theft designation.* If the prior title for a vehicle is a foreign title indicating that the vehicle was damaged by flood, fire or vandalism or is a recovered stolen vehicle and another designation is not required under this rule or rule 761—405.10(321), the Iowa title and registration receipt issued from the foreign title shall contain, as applicable, the designation of “flood,” “fire,” “vandalism” or “theft.”

**405.8(7)** *Foreign title with a lemon buy-back designation.* See rule 761—405.10(321).

**405.8(8)** *Junking certificate.*

a. An Iowa junking certificate shall be issued if:

- (1) The prior title for a vehicle is a foreign title indicating that the vehicle was junked, regardless of any other designation on the title.
- (2) A records check for a vehicle with a foreign title indicates that the vehicle had previously been issued an Iowa junking certificate.

b. This subrule applies to all vehicles subject to Iowa titling laws.

[ARC 3108C, IAB 6/7/17, effective 7/12/17; ARC 5345C, IAB 12/30/20, effective 2/3/21; ARC 6220C, IAB 3/9/22, effective 4/13/22]

**761—405.9(321) Records check.** Before a title is issued in Iowa, a computer records check may be made. The purpose of the records check is to:

**405.9(1)** Determine if the vehicle ever had or should have had a “prior salvage,” “rebuilt,” “damage over 50 percent,” “damage over 70 percent,” “flood,” “fire,” “vandalism,” “theft,” “lemon buy-back,” or equivalent designation(s) on a previous title. If such a designation is or should have been on a previous title, the Iowa title to be issued shall contain the designation required by this chapter.

**405.9(2)** Determine if the vehicle is or was ever a wrecked or salvage vehicle as defined in Iowa Code section 321.52. If a vehicle is a wrecked or salvage vehicle, an Iowa salvage title shall be issued. If the vehicle was a wrecked or salvage vehicle, the Iowa title to be issued shall contain the appropriate designation required by this chapter.

**405.9(3)** Determine if the vehicle should have been or was ever junked as defined in subrule 405.8(1). If the vehicle should have been or was ever junked, an Iowa junking certificate shall be issued.

[ARC 6220C, IAB 3/9/22, effective 4/13/22]

**761—405.10(321,322G) Designations.**

**405.10(1)** The following designations for a vehicle shall be used on Iowa titles and registrations receipts and shall be carried forward to all subsequent Iowa titles and registration receipts issued for the vehicle, unless otherwise specified:

*a.* “REBUILT-IA.” This designation supersedes other designations. When a designation of “REBUILT-IA” is required pursuant to rule 761—405.7(321), it replaces any other designation.

*b.* Rebuilt together with a two-letter abbreviation of the name of a foreign jurisdiction. When this designation is required pursuant to subrule 405.8(2), it replaces any other designation except a “REBUILT-IA” designation.

*c.* Damage over 50 percent. The designation shall be used for applicable vehicle transfers occurring prior to July 1, 2021, and shall be carried forward for applicable vehicle transfers occurring prior to July 1, 2021.

*d.* Damage over 70 percent. As required by Iowa Code section 321.69, a designation of “damage over 70 percent” shall be used when the seller or the buyer indicates on the damage disclosure statement that the person has knowledge that the motor vehicle sustained damage for which the cost of the repair exceeded 70 percent of the fair market value before the motor vehicle became damaged. This designation replaces any other designation except “rebuilt.”

*e.* Flood, fire, vandalism or theft. The most recent designation applies. Unless superseded by a “REBUILT-IA,” “rebuilt,” “damage over 50 percent” or “damage over 70 percent” designation, a designation of “flood,” “fire,” “vandalism” or “theft” shall be used as specified in subrule 405.8(6) and supersedes a “lemon buy-back” designation.

*f.* Lemon buy-back. Unless superseded by a “REBUILT-IA,” “rebuilt,” “damage over 50 percent,” “damage over 70 percent,” “flood,” “fire,” “vandalism” or “theft” designation, a designation of “lemon buy-back” shall be used:

(1) When a certificate of title is issued to a manufacturer of a motor vehicle pursuant to Iowa Code section 322G.12.

(2) When the prior certificate of title for a motor vehicle is a foreign title indicating that the vehicle was returned to the manufacturer pursuant to Iowa Code chapter 322G or a law of another state similar to Iowa Code chapter 322G.

**405.10(2)** An Iowa salvage title will be issued with a designation of “salvage” unless a designation listed in subrule 405.10(1) is required.

[ARC 5345C, IAB 12/30/20, effective 2/3/21; ARC 6220C, IAB 3/9/22, effective 4/13/22]

**761—405.11 to 405.14** Reserved.

**761—405.15(321) Salvage theft examination.** Except for foreign salvage titles assigned to licensed new motor vehicle dealers, authorized vehicle recyclers, or educational institutions, a salvage theft examination may only be conducted on a vehicle with an Iowa salvage title. The vehicle shall not be examined until it has been completely repaired, except for minor body parts such as trim, body marking or paint.

**405.15(1) General procedure.**

*a.* A salvage theft examination shall be conducted by a peace officer who has been specially certified, and recertified when required, by the Iowa law enforcement academy to perform salvage theft examinations.

(1) To arrange for a salvage theft examination by an investigator from the department, the applicant shall contact the Bureau of Investigation and Identity Protection, Iowa Department of Transportation, 6310 SE Convenience Blvd., Ankeny, Iowa 50021; by telephone at (515)237-3050; or on the department’s website at [www.iowadot.gov](http://www.iowadot.gov).

(2) To arrange for a salvage theft examination by any other authorized peace officer, the applicant shall contact the local law enforcement agency for instructions.

*b.* The owner of the vehicle may drive the vehicle to and from the examination location by completing the permit to drive located within the electronic affidavit of salvage vehicle repairs form.

(1) The affidavit shall state that the vehicle is reasonably safe for operation and shall list the parts that have been replaced on the vehicle. The affidavit must be signed by the owner or the owner’s authorized agent.

(2) To be valid, the permit to drive the vehicle to and from the examination location must be signed by the owner or owner’s authorized agent.

*c.* The owner of the vehicle or the owner’s representative must be present for the examination.

*d.* The owner or owner’s representative, when appearing with the vehicle for the examination, shall submit to the peace officer for review the salvage title or a certified copy of the salvage title; the affidavit of salvage vehicle repairs; and, pursuant to subrules 405.15(3) and 405.15(4), bills of sale for all component parts replaced.

*e.* The owner or owner’s representative shall electronically make payment for the salvage theft examination at the time the examination is scheduled, and the fee collected shall be distributed in accordance with Iowa Code section 321.52(4)“c.” The owner shall have three years from the date the affidavit and payment were submitted to complete the salvage theft examination without having to pay a new fee.

*f.* If the vehicle passes the salvage theft examination, the peace officer shall approve the completed salvage theft examination certificate.

*g.* Reserved.

*h.* The peace officer shall return the salvage title or the certified copy of the salvage title, the permit to drive section, if applicable, on the affidavit of salvage vehicle repairs, and the bills of sale to the owner or the owner's representative.

**405.15(2)** *Affidavit of salvage vehicle repairs form and salvage theft examination certificate.*

*a.* The affidavit of salvage vehicle repairs form shall be accessed on the department's website.

*b.* If a peace officer finds it necessary to use a physical salvage theft examination certificate, the salvage theft examination certificate shall be a controlled form and furnished by the department.

*c.* The owner of the vehicle may obtain a duplicate copy of the salvage theft examination certificate upon written request to the department.

*d.* The approved salvage theft examination certificate is not transferable to a different party or owner.

**405.15(3)** *Bill of sale.* A bill of sale is a document from the seller to the buyer containing the name, address and telephone number of the seller, a description and identification number of the component part and, if applicable, the vehicle identification number (VIN) of the vehicle from which it was removed.

**405.15(4)** *Component part.* For salvage theft examinations, the definition of component part as found in Iowa Code section 321.1 shall apply.

[ARC 0136C, IAB 5/30/12, effective 7/4/12; ARC 3108C, IAB 6/7/17, effective 7/12/17; ARC 5345C, IAB 12/30/20, effective 2/3/21]

These rules are intended to implement Iowa Code sections 321.24, 321.52, 321.69 and 322G.12.

[Filed emergency 6/22/88—published 7/13/88, effective 7/1/88]

[Filed 10/10/88, Notice 7/13/88—published 11/2/88, effective 12/7/88]

[Filed emergency 11/30/89—published 12/27/89, effective 12/1/89]

[Filed 1/15/92, Notice 12/11/91—published 2/5/92, effective 3/11/92]

[Filed emergency 3/26/92—published 4/15/92, effective 4/29/92]

[Filed 1/14/93, Notice 12/9/92—published 2/3/93, effective 3/10/93]

[Filed 11/29/95, Notice 10/25/95—published 12/20/95, effective 1/24/96]

[Filed 7/18/01, Notice 5/30/01—published 8/8/01, effective 9/12/01]

[Filed 12/19/01, Notice 11/14/01—published 1/23/02, effective 2/27/02]

[Filed 10/11/07, Notice 8/15/07—published 11/7/07, effective 12/12/07]

[Filed ARC 9048B (Notice ARC 8869B, IAB 6/30/10), IAB 9/8/10, effective 10/13/10]

[Filed ARC 0136C (Notice ARC 0068C, IAB 4/4/12), IAB 5/30/12, effective 7/4/12]

[Filed ARC 3108C (Notice ARC 2989C, IAB 3/29/17), IAB 6/7/17, effective 7/12/17]

[Filed ARC 3999C (Notice ARC 3890C, IAB 7/18/18), IAB 9/12/18, effective 10/17/18]

[Filed ARC 5345C (Notice ARC 5233C, IAB 10/21/20), IAB 12/30/20, effective 2/3/21]

[Filed ARC 6220C (Notice ARC 6066C, IAB 12/1/21), IAB 3/9/22, effective 4/13/22]



CHAPTERS 406 to 409  
Reserved



CHAPTER 410  
SPECIAL MOBILE EQUIPMENT

**761—410.1(321) General.**

**410.1(1)** Special mobile equipment is defined in Iowa Code section 321.1.

**410.1(2)** Special mobile equipment is exempt from the titling and registration provisions of Iowa Code sections 321.18 and 321.20. However, a certificate of title and registration may be obtained in accordance with Iowa Code chapter 321 for a motor truck, trailer or semitrailer with special mobile equipment permanently attached.

**410.1(3)** Questions regarding special mobile equipment may be directed by mail to the Vehicle and Motor Carrier Services Bureau, Iowa Department of Transportation, P.O. Box 10382, Des Moines, Iowa 50306-0382; in person at 6310 SE Convenience Blvd., Ankeny, Iowa; by telephone at (515)237-3268; or by email at [omcs@iowadot.us](mailto:omcs@iowadot.us).

This rule is intended to implement Iowa Code sections 321.1, 321.18 and 321.20.

[ARC 2887C, IAB 1/4/17, effective 2/8/17; ARC 5046C, IAB 6/3/20, effective 7/8/20]

**761—410.2(321E) Special mobile equipment transported on a registered vehicle.** The movement of special mobile equipment or component parts of special mobile equipment transported on a vehicle registered for the gross weight of the vehicle without load, as provided in Iowa Code section 321E.12, is subject to the following:

**410.2(1)** A vehicle registered for its gross weight without load shall not be used to transport special mobile equipment in a for-hire operation.

**410.2(2)** If the special mobile equipment is leased, the lease agreement or a certified copy of the lease agreement shall be carried in the cab of the transporting vehicle.

**410.2(3)** All movements of special mobile equipment shall comply with the size and weight limits in Iowa Code chapter 321 unless a permit to exceed these limits is obtained in accordance with Iowa Code chapter 321E.

This rule is intended to implement Iowa Code section 321E.12.

[ARC 2887C, IAB 1/4/17, effective 2/8/17]

**761—410.3(321E) Special mobile equipment transported on a registered vehicle.** Rescinded IAB 5/31/00, effective 7/5/00.

[Filed 2/7/90, Notice 12/27/89—published 3/7/90, effective 4/11/90]

[Filed emergency 3/26/92—published 4/15/92, effective 4/29/92]

[Filed 4/8/93, Notice 3/3/93—published 4/28/93, effective 6/2/93<sup>1</sup>]

[Filed 12/16/93, Notice 11/10/93—published 1/5/94, effective 2/9/94]

[Filed 5/10/00, Notice 4/5/00—published 5/31/00, effective 7/5/00]

[Filed 12/12/07, Notice 11/7/07—published 1/2/08, effective 2/6/08]

[Filed ARC 2887C (Notice ARC 2780C, IAB 10/26/16), IAB 1/4/17, effective 2/8/17]

[Filed ARC 5046C (Notice ARC 4939C, IAB 2/26/20), IAB 6/3/20, effective 7/8/20]

<sup>1</sup> Effective date of 410.3(2), June 2, 1993, delayed 70 days by the Administrative Rules Review Committee at its meeting held May 12, 1993; delay lifted by this Committee June 8, 1993, effective June 9, 1993.



CHAPTER 411  
PERSONS WITH DISABILITIES PARKING PERMITS

[Prior to 6/3/87, Transportation Department [820]—(07.D) Ch 1]

**761—411.1(321L) Information and applications.** Information and applications regarding persons with disabilities parking permits are available, electronically or otherwise, by mail from the Motor Vehicle Division, Iowa Department of Transportation, P.O. Box 9278, Des Moines, Iowa 50306-9278; in person at 6310 SE Convenience Blvd., Ankeny, Iowa; by telephone at (515)237-3110; by facsimile at (515)237-3056; by email at [vsusto@iowadot.us](mailto:vsusto@iowadot.us); or on the department's website at [www.iowadot.gov](http://www.iowadot.gov).

[ARC 3450C, IAB 11/8/17, effective 12/13/17; ARC 6218C, IAB 3/9/22, effective 4/13/22]

**761—411.2(321L) Definitions.**

**411.2(1)** The definitions in Iowa Code section 321L.1 are hereby made part of and fully incorporated in this chapter.

**411.2(2)** As used in this chapter:

*“Child”* means the same as defined in 761—subrule 401.20(2).

*“Health care provider”* means a physician licensed under Iowa Code chapter 148 or 149, a physician assistant licensed under Iowa Code chapter 148C, an advanced registered nurse practitioner licensed under Iowa Code chapter 152, a chiropractor licensed under Iowa Code chapter 151, an occupational therapist licensed under Iowa Code chapter 148B, a physical therapist licensed under Iowa Code chapter 148A, or a physician, physician assistant, nurse practitioner, chiropractor, occupational therapist, or physical therapist licensed to practice in another state as set forth in Iowa Code section 321L.2(1) as amended by 2022 Iowa Acts, House File 2259, section 2.

*“Nonexpiring removable windshield placard”* means a removable windshield placard issued on or before December 31, 2016, to a person with a permanent disability.

*“Organization”* means an applicant that is a corporation, partnership, sole proprietorship, business trust, estate, trust, limited liability company, association, joint venture, government, governmental subdivision, agency, instrumentality, public corporation, or any other legal or commercial entity lawfully doing business in the state of Iowa that has a program for transporting persons with disabilities or elderly persons.

*“Permanent disability”* means an applicant is a person with a disability as defined in Iowa Code section 321L.1(8) and the disability will continue indefinitely without resolution and is reasonably expected to last the applicant's lifetime.

*“Standard removable windshield placard”* means a removable windshield placard issued on or after January 1, 2017, to a person with a permanent disability.

*“Statement of disability”* means a communication, electronic or otherwise, originating from the applicant's health care provider, which attests that the applicant is a person with a disability as defined in Iowa Code section 321L.1(8). The statement must state the nature of the applicant's disability and indicate whether the applicant's disability is “temporary” or “permanent.” If the disability is temporary, the statement shall state the period of time during which the applicant is expected to be disabled and the period of time for which the permit should be issued, not to exceed six months. The statement must be written on the health care provider's stationery.

*“Stationery”* means any communication, electronic or otherwise, from which the department may reasonably identify, on or within its contents, that it originated from the applicant's health care provider.

*“Temporary disability”* means an applicant is a person with a disability as defined in Iowa Code section 321L.1(8) and the disability is not permanent and is reasonably expected to last for only a limited period of time.

*“Temporary removable windshield placard”* means a removable windshield placard issued to a person with a temporary disability.

[ARC 3450C, IAB 11/8/17, effective 12/13/17; ARC 6218C, IAB 3/9/22, effective 4/13/22; ARC 6615C, IAB 11/2/22, effective 12/7/22]

**761—411.3(321L) Application for persons with disabilities parking permit.**

**411.3(1) General.** An applicant shall submit a completed application for a persons with disabilities parking permit, including required supporting documentation, pursuant to this chapter and Iowa Code section 321L.2.

*a.* An applicant may request one of the following persons with disabilities parking permits by completing Form 411055:

(1) Temporary removable windshield placard.

(2) Standard removable windshield placard.

(3) Persons with disabilities special registration plate parking sticker.

(4) Persons with disabilities special registration plates. An applicant seeking persons with disabilities special registration plates must also submit an application as described in rule 761—401.20(321).

b. An organization seeking a persons with disabilities removable windshield placard shall complete Form 411355. An application made by an organization does not have to include a statement of disability.

**411.3(2) Application requirements.** An application shall include the applicant's full legal name, address, date of birth, social security number or Iowa driver's license number or Iowa nonoperator's identification number, and a statement of disability from the applicant's health care provider. However, if the application is made on behalf of a person who is less than one year old, pursuant to Iowa Code section 321L.2, the department may accept the application without the requirement to include a social security number, Iowa driver's license number, or nonoperator's identification card number for the person. In lieu of a statement of disability from a health care provider, an applicant who is certified by the U.S. Department of Veterans Affairs as having a permanent disability may submit both of the following with an otherwise completed persons with disabilities parking permit application:

a. Proof that the applicant is the subject of a certification of disability from the U.S. Department of Veterans Affairs.

b. A self-certification, verified under penalty of perjury, that states the nature of the applicant's disability and attests that the disability certified by the U.S. Department of Veterans Affairs is a permanent disability that impairs the applicant's mobility to the extent defined in Iowa Code section 321L.1(8). The self-certification must be attested to on the persons with disabilities parking permit application.

**411.3(3) Availability of application.** Applications may be obtained from any of the following:

- a. The department's website as set forth in rule 761—411.1(321L).
- b. The department's motor vehicle division.
- c. A driver's license service center.
- d. A county treasurer's office.

**411.3(4) Application submission.** Completed applications shall be submitted in any of the following ways:

a. By mail to the Motor Vehicle Division, Iowa Department of Transportation, P.O. Box 9278, Des Moines, Iowa 50306-9278; in person at 6310 SE Convenience Blvd., Ankeny, Iowa; by facsimile at (515)237-3056; or by email at [vsusto@iowadot.us](mailto:vsusto@iowadot.us).

- b. In person at a driver's license service center.
- c. To the county treasurer's office.

**411.3(5) Application submitted by an organization.** An application submitted by an organization shall include the name of the organization; the name of its authorized representative; the mailing address, telephone number, and signature of its authorized representative; and if required to obtain one, the organization's federal employer identification number or federal tax identification number.

[ARC 3450C, IAB 11/8/17, effective 12/13/17; ARC 6218C, IAB 3/9/22, effective 4/13/22]

#### **761—411.4(321L) Removable windshield placards.**

**411.4(1) Nonexpiring removable windshield placards.**

a. *Period of validity.* A nonexpiring removable windshield placard issued on or before December 31, 2016, shall remain valid until the occurrence of any condition set forth in Iowa Code section 321L.3(1), the procedure set forth in rule 761—411.8(321L), and as otherwise specified by statute or rule.

b. *Replacement.* A lost, stolen, or damaged nonexpiring removable windshield placard shall be replaced with a standard removable windshield placard.

**411.4(2) Standard removable windshield placards.** A standard removable windshield placard may be issued only to a person with a permanent disability. A standard removable windshield placard shall not be issued to a person with a temporary disability or to an organization.

a. *Period of validity.* A standard removable windshield placard shall be valid for five years, and shall expire on the last day of the last month, five years from the month from which it was issued.

b. *Renewal.*

(1) Submission of application. A person who holds a valid standard removable windshield placard may renew the placard by submitting a persons with disabilities parking permit application pursuant to rule 761—411.3(321L) that includes all required documentation and shows the applicant remains permanently disabled and has a continuing need for the placard.

(2) Timing of renewal application. An application to renew a standard removable windshield placard may be submitted up to 30 days before the current placard's expiration. The renewal or replacement placard shall be valid for five years, and shall expire on the last day of the last month, five years from the month from which it was issued.

**411.4(3) Temporary removable windshield placards.** A temporary removable windshield placard may be issued to the applicant if the application demonstrates the applicant has a temporary disability. A temporary removable windshield placard shall not be issued to an organization.

*a. Period of validity.* A temporary removable windshield placard shall be valid for the period of time during which the applicant is expected to be disabled and the period of time for which the permit should be issued as shown by the statement of disability, but not to exceed six months.

*b. Renewal.*

(1) Submission of application. A person who holds a valid temporary removable windshield placard may renew the placard by submitting a persons with disabilities parking permit application pursuant to rule 761—411.3(321L) that includes all required documentation and shows the applicant remains temporarily disabled.

(2) Timing of renewal application. An application to renew a temporary removable windshield placard may be submitted up to 30 days before the current placard's expiration. The renewal placard shall be valid for the period of time during which the applicant is expected to be disabled and the period of time for which the permit should be issued as shown by the statement of disability, but not to exceed six months.

**411.4(4) Removable windshield placards for an organization.** An organization may be issued a removable windshield placard. A removable windshield placard issued to an organization shall be valid for four years and shall expire on the last day of the last month, four years from the month from which it was issued. The placard shall bear the name of the organization and the signature of its authorized representative. The organization may renew a placard issued to it by submitting a persons with disabilities parking permit application pursuant to rule 761—411.3(321L) provided the organization continues to provide the service for which the placard was issued. If at any time the organization ceases providing the service for which the placard was issued, the organization shall immediately surrender the placard to the department.

**411.4(5) Display of placards.** A removable windshield placard shall only be displayed when the vehicle is parked in a persons with disabilities parking space. The removable windshield placard shall be displayed in a manner that allows the entire placard to be visible through the vehicle's windshield.

[ARC 3450C, IAB 11/8/17, effective 12/13/17]

#### **761—411.5(321L) Persons with disabilities special registration plate parking stickers.**

**411.5(1) Eligibility.** A persons with disabilities special registration plate parking sticker may be issued to a person with a permanent disability who owns a motor vehicle for which the person has been issued disabled veteran plates under Iowa Code section 321.105 or registration plates under Iowa Code section 321.34. A special registration plate parking sticker shall not be issued to a person with a temporary disability or to an organization. In no event shall a special registration plate parking sticker be placed on persons with disabilities special plates issued under Iowa Code section 321.34(14).

**411.5(2) Validity.** The special registration plate parking sticker shall remain valid for such period of time that the registration for the vehicle remains valid.

**411.5(3) Display.** The special registration plate parking sticker shall be affixed to the lower right corner of the rear registration plate, as required by rule 761—400.53(321).

[ARC 3450C, IAB 11/8/17, effective 12/13/17; ARC 6218C, IAB 3/9/22, effective 4/13/22]

#### **761—411.6(321L) Persons with disabilities special registration plates.** See 761—Chapter 401.

[ARC 3450C, IAB 11/8/17, effective 12/13/17]

**761—411.7(321L) Return of persons with disabilities parking permit.** A persons with disabilities parking permit issued pursuant to this chapter and Iowa Code section 321L.2 shall be returned to the department, to a driver's license service center, or to any law enforcement office within ten days of an occurrence of any of the events set forth in Iowa Code section 321L.3(1) and in the manner prescribed in Iowa Code section 321L.3(3).

[ARC 3450C, IAB 11/8/17, effective 12/13/17; ARC 6218C, IAB 3/9/22, effective 4/13/22]

#### **761—411.8(321L) Revocation of a persons with disabilities parking permit.**

**411.8(1) Notice of revocation.** Notice of revocation shall be in writing and shall specify the basis of the department's determination.

**411.8(2) Effective date of permit revocation.** Unless otherwise specified by statute or rule, a permit shall be considered revoked 30 days after the department's notice of revocation is served.

**411.8(3) Service of notice.** The department shall send a notice of revocation by first-class mail to the mailing address as shown on the pertinent application for a persons with disabilities parking permit.

**411.8(4) Departmental verification of service of notice.** The department may prepare an affidavit of mailing verifying the fact that a notice was mailed by first-class mail. To verify the mailing of a notice, the department may use its records in conjunction with U.S. Postal Service records available to the department. The department's affidavit of mailing may be attested to and certified in accordance with Iowa Code section 622.1.

[ARC 3450C, IAB 11/8/17, effective 12/13/17]

**761—411.9(321L) Appeal.**

**411.9(1)** A person or organization whose persons with disabilities parking permit has been revoked may request an informal settlement or a contested case proceeding as provided in 761—Chapter 13 to contest said action.

**411.9(2)** The request shall be submitted in writing, to the director of the motor vehicle division, at the address listed in rule 761—411.1(321L), and may be submitted by email or other means prescribed by the department. To be timely, the request must be submitted within ten days of the receipt of notice of revocation.

**411.9(3)** When the department receives a properly submitted, timely request for an informal settlement or contested case proceeding or an appeal of a presiding officer's proposed decision regarding a revocation, the department shall stay the revocation pending resolution of the informal resolution, contested case, or appeal.

[ARC 3450C, IAB 11/8/17, effective 12/13/17; ARC 6218C, IAB 3/9/22, effective 4/13/22]

These rules are intended to implement Iowa Code sections 321L.1, 321L.2 as amended by 2022 Iowa Acts, House File 2259, section 2, 321L.3, 321L.4 and 321L.8.

[Filed 11/22/76, Notice 10/6/76—published 12/15/76, effective 1/19/77]

[Filed 12/16/81, Notice 10/28/81—published 1/6/82, effective 2/10/82]

[Filed 5/11/87, Notice 3/11/87—published 6/3/87, effective 7/8/87]

[Filed 11/1/89, Notice 9/20/89—published 11/29/89, effective 1/3/90]

[Filed 12/5/90, Notice 10/17/90—published 12/26/90, effective 1/30/91]

[Filed 1/15/92, Notice 12/11/91—published 2/5/92, effective 3/11/92]

[Filed 12/18/92, Notice 10/28/92—published 1/6/93, effective 2/10/93]

[Filed 12/16/93, Notice 11/10/93—published 1/5/94, effective 2/9/94]

[Filed 11/29/95, Notice 10/25/95—published 12/20/95, effective 1/24/96]

[Filed 9/24/97, Notice 8/13/97—published 10/22/97, effective 11/26/97]

[Filed 10/28/98, Notice 8/26/98—published 11/18/98, effective 12/23/98]

[Filed 6/19/02, Notice 4/17/02—published 7/10/02, effective 8/14/02]

[Filed 11/2/05, Notice 9/14/05—published 11/23/05, effective 12/28/05]

[Filed 10/11/07, Notice 8/15/07—published 11/7/07, effective 12/12/07]

[Filed ARC 3450C (Notice ARC 3304C, IAB 9/13/17), IAB 11/8/17, effective 12/13/17]

[Filed ARC 6218C (Notice ARC 6075C, IAB 12/15/21), IAB 3/9/22, effective 4/13/22]

[Filed ARC 6615C (Notice ARC 6465C, IAB 8/10/22), IAB 11/2/22, effective 12/7/22]

CHAPTERS 412 to 414  
Reserved

CHAPTER 415  
DRIVER'S PRIVACY PROTECTION—CERTIFICATES  
OF TITLE AND VEHICLE REGISTRATION  
Rescinded **ARC 6060C**, IAB 12/1/21, effective 1/5/22

CHAPTERS 416 to 419  
Reserved

CHAPTER 420  
MOTOR VEHICLE DEALERS, MANUFACTURERS AND DISTRIBUTORS  
[Prior to 6/3/87, Transportation Department[820]—(07,D) Ch 10]  
Rescinded IAB 7/17/96, effective 8/21/96. See 761—Chapter 425.

CHAPTER 421  
MANUFACTURED OR MOBILE HOME RETAILERS, MANUFACTURERS  
AND DISTRIBUTORS  
[Prior to 6/3/87, Transportation Department[820]—(07,D) Ch 7]  
Rescinded IAB 11/7/07, effective 12/12/07

CHAPTER 422  
TRAVEL TRAILER DEALERS, MANUFACTURERS AND DISTRIBUTORS  
[Prior to 6/3/87, Transportation Department[820]—(07,D) Ch 8]  
Rescinded IAB 7/17/96, effective 8/21/96. See 761—Chapter 425.

CHAPTER 423  
Reserved



CHAPTER 424  
TRANSPORTER PLATES

[Prior to 6/3/87, Transportation Department[820]—(07,D) Ch 5]

**761—424.1(321) General.**

**424.1(1) Information.** Information and blank forms relating to this chapter may be obtained from the Vehicle and Motor Carrier Services Bureau, Iowa Department of Transportation, by mail at P.O. Box 9278, Des Moines, Iowa 50306-9278; in person at 6310 SE Convenience Blvd., Ankeny, Iowa; by telephone at (515)237-3110; by email at [vscto@iowadot.us](mailto:vscto@iowadot.us); or from the department's website at [www.iowadot.gov](http://www.iowadot.gov). Completed forms shall be submitted in the form and manner prescribed by the department.

**424.1(2) Definitions.**

"Dealer plate" means a special plate, other than a transporter plate, as authorized by Iowa Code sections 321.57 to 321.63.

"Department" means the Iowa department of transportation.

"Operating authority" means the authority issued by the department or the Federal Motor Carrier Safety Administration under Iowa Code chapter 325A or 327B that is required for the delivery of a vehicle for compensation.

"Transporter" means a person who is engaged in the business of delivering vehicles owned by the person or delivering vehicles owned by other persons for compensation and who has an established place of business for such purpose in this state. An authorized vehicle recycler under Iowa Code chapter 321H who delivers vehicles in the course of the recycler's business meets this definition.

"Transporter plate" means a special plate for transporters as authorized by Iowa Code sections 321.57 to 321.63.

[ARC 2755C, IAB 10/12/16, effective 11/16/16; ARC 5548C, IAB 4/7/21, effective 5/12/21]

**761—424.2 and 424.3 Reserved.**

**761—424.4(321) Transporter plates.**

**424.4(1) Eligibility for plates.** A transporter, as defined in subrule 424.1(2), may obtain transporter plates from the department.

**424.4(2) Application.** The applicant shall accurately and completely fill out an application for special plates on a form prescribed by the department and submit the application in the manner prescribed by the department with the appropriate fees in accordance with Iowa Code sections 321.58 through 321.60.

*a.* The application shall include the name, bona fide business address, and telephone number under which the applicant will conduct business as a transporter.

*b.* If the owner of the business is an individual, the application shall include the legal name, bona fide address, and telephone number of the individual. If the owner is a partnership, the application shall include the legal name, bona fide address, and telephone number of two partners. If the owner is a corporation, the application shall include the legal name, bona fide address, and telephone number of two corporate officers. In all cases, the telephone number must be a number where the individual, partner, or corporate officer can be reached during normal business hours.

*c.* The application shall include the federal employer identification number of the business. However, if the business is owned by an individual who is not required to have a federal employer identification number, the application shall include the individual's social security number, Iowa nonoperator's identification number or Iowa driver's license number.

*d.* The applicant must certify on the application that it possesses all necessary operating authority to conduct business as a transporter in the state.

**424.4(3) Permitted uses of a transporter plate.** The person delivering the vehicle must carry evidence issued by the owner of the vehicle authorizing the delivery. The evidence shall include the origin and destination of the vehicle delivery, the vehicle owner's name and address, and a description of the vehicle being delivered. Subject to these stipulations, a transporter plate may be displayed on a vehicle being operated or moved on the highway for the purpose of delivery to a place designated by the owner of the vehicle.

**424.4(4) Prohibited uses of a transporter plate.** A transporter plate shall not be displayed on a vehicle that is not being delivered or displayed in any manner not specifically permitted under Iowa Code section 321.57 or subrule 424.4(3).

[ARC 5548C, IAB 4/7/21, effective 5/12/21]

These rules are intended to implement Iowa Code sections 321.1 and 321.57 to 321.63.

[Filed emergency 6/20/86—published 7/16/86, effective 7/1/86]

[Filed 5/11/87, Notice 3/11/87—published 6/3/87, effective 7/8/87]

[Filed emergency 6/22/88—published 7/13/88, effective 7/1/88]

[Filed emergency 11/30/89—published 12/27/89, effective 12/1/89]

[Filed 12/16/93, Notice 11/10/93—published 1/5/94, effective 2/9/94]

[Filed 6/19/02, Notice 4/17/02—published 7/10/02, effective 8/14/02]

[Filed 10/11/07, Notice 8/15/07—published 11/7/07, effective 12/12/07]

[Filed ARC 2755C (Notice ARC 2640C, IAB 8/3/16), IAB 10/12/16, effective 11/16/16]

[Filed ARC 5548C (Notice ARC 5413C, IAB 2/10/21), IAB 4/7/21, effective 5/12/21]

CHAPTER 425  
MOTOR VEHICLE AND TOWABLE RECREATIONAL VEHICLE DEALERS,  
MANUFACTURERS, DISTRIBUTORS AND WHOLESALERS

[Prior to 7/17/96, see 761—Chapters 420 and 422]

**761—425.1(322) Introduction.**

**425.1(1)** This chapter applies to the licensing of motor vehicle and towable recreational vehicle dealers, manufacturers, distributors and wholesalers. Also included in this chapter are the criteria for the issuance and use of dealer plates.

**425.1(2)** The vehicle and motor carrier services bureau administers this chapter. The mailing address is: Vehicle and Motor Carrier Services Bureau, Iowa Department of Transportation, P.O. Box 9278, Des Moines, Iowa 50306-9278.

*a.* Applications required by the chapter shall be submitted to the vehicle and motor carrier services bureau.

*b.* Information about dealer plates and the licensing of motor vehicles and towable recreational vehicle dealers, manufacturers, distributors and wholesalers is available from the vehicle and motor carrier services bureau or on the department's website at [www.iowadot.gov](http://www.iowadot.gov).

[ARC 9048B, IAB 9/8/10, effective 10/13/10; ARC 3687C, IAB 3/14/18, effective 4/18/18; ARC 4960C, IAB 3/11/20, effective 4/15/20]

**761—425.2** Reserved.

**761—425.3(322) Definitions.** The following definitions, in addition to those found in Iowa Code sections 322.2 and 322C.2, apply to this chapter of rules:

*“Certificate of title”* means a document issued by the appropriate official which contains a statement of the owner's title, the name and address of the owner, a description of the vehicle, a statement of all security interests, and additional information required under the laws or rules of the jurisdiction in which the document was issued, and which is recognized as a matter of law as a document evidencing ownership of the vehicle described. The terms “title certificate,” “title only” and “title” shall be synonymous with the term “certificate of title.”

*“Consumer use”* means use of a motor vehicle or towable recreational vehicle for business or pleasure, not for sale at retail, by a person who has obtained a certificate of title and has registered the vehicle under Iowa Code chapter 321.

*“Dealer,”* unless otherwise specified, means a person who is licensed to engage in this state in the business of selling motor vehicles or towable recreational vehicles at retail under Iowa Code chapter 322 or 322C.

*“Engage in this state in the business”* or similar wording means doing any of the following acts for the purpose of selling motor vehicles or towable recreational vehicles at retail: to acquire, sell, exchange, hold, offer, display, broker, accept on consignment or conduct a retail auction, advertise as being engaged in any of those acts, or to act as an agent for the purpose of doing any of those acts. A person selling at retail more than six motor vehicles or six towable recreational vehicles during a 12-month period may be presumed to be engaged in the business. See rule 761—425.20(322) for provisions regarding fleet sales and retail auction sales.

*“Manufacturer's certificate of origin”* means a certification signed by the manufacturer, distributor or importer that the vehicle described has been transferred to the person or dealer named, and that the transfer is the first transfer of the vehicle in ordinary trade and commerce. The terms “manufacturer's statement,” “importer's statement or certificate,” “MSO” and “MCO” shall be synonymous with the term “manufacturer's certificate of origin.” See rule 761—400.1(321) for more information.

*“Principal place of business”* means a building actually occupied where the public and the department may contact the owner or operator during regular business hours. In lieu of a building, a towable recreational vehicle dealer may use a manufactured or mobile home as an office if taxes are current or a towable recreational vehicle as an office if registration fees are current. The principal place of business must be located in this state.

*“Registered dealer”* means a dealer licensed under Iowa Code chapter 322 or 322C who possesses a current dealer certificate under Iowa Code section 321.59.

*“Regular business hours”* means to be consistently open to the public on a weekly basis at hours reported to the vehicle and motor carrier services bureau. Except as provided in Iowa Code section 322.36, regular business hours for a motor vehicle or towable recreational vehicle dealer shall include a minimum of 32 posted hours between 7 a.m. and 9 p.m., Monday through Friday.

*“Salesperson”* means a person employed by a motor vehicle or towable recreational vehicle dealer for the purpose of buying or selling vehicles.

*“Vehicle,”* unless otherwise specified, means a motor vehicle or towable recreational vehicle.

*“Wholesaler”* means a person who sells new vehicles to dealers and not at retail.

This rule is intended to implement Iowa Code chapters 322 and 322C.

[ARC 9048B, IAB 9/8/10, effective 10/13/10; ARC 0136C, IAB 5/30/12, effective 7/4/12; ARC 0778C, IAB 6/12/13, effective 7/17/13; ARC 3687C, IAB 3/14/18, effective 4/18/18; ARC 4960C, IAB 3/11/20, effective 4/15/20]

**761—425.4 to 425.9** Reserved.

**761—425.10(322) Application for dealer's license.**

**425.10(1) Application form.** To apply for a license as a motor vehicle or towable recreational vehicle dealer, the applicant shall complete an application on a form prescribed by the department.

**425.10(2) Surety bond.**

*a.* The applicant shall obtain a surety bond in the following amounts and file the original with the vehicle and motor carrier services bureau:

(1) For a motor vehicle dealer's license, \$75,000. However, an applicant for a motor vehicle dealer's license is not required to file a bond if the person is licensed as a towable recreational vehicle dealer under the same name and at the same principal place of business.

(2) For a towable recreational vehicle dealer's license, \$75,000. However, an applicant for a towable recreational vehicle dealer's license is not required to file a bond if the person is licensed as a motor vehicle dealer under the same name and at the same principal place of business.

*b.* The surety bond shall provide for notice to the vehicle and motor carrier services bureau at least 30 days before cancellation.

*c.* The vehicle and motor carrier services bureau shall notify the bonding company of any conviction of the dealer for a violation of laws related to the operations of the dealership.

*d.* If the bond is canceled, the vehicle and motor carrier services bureau shall notify the dealer by first-class mail that the dealer's license shall be revoked on the same date that the bond is canceled unless the bond is reinstated or a new bond is filed.

*e.* If an applicant whose dealer's license was revoked pursuant to paragraph 425.10(2) "d" establishes that the applicant obtained a reinstated or new bond meeting the requirements of this subrule that was effective on or before the date of cancellation, but due to mistake or inadvertence failed to file the original bond with the vehicle and motor carrier services bureau, the applicant may file the original of the reinstated or new bond. Upon filing, the department will rescind the revocation of the dealer's license.

**425.10(3) Franchise.**

*a.* An applicant who intends to sell new motor vehicles or towable recreational vehicles shall submit to the vehicle and motor carrier services bureau a copy of a signed franchise agreement with the manufacturer or distributor of each make the applicant intends to sell.

*b.* If a signed franchise agreement is not available at the time of application, the department may accept written evidence of a franchise which includes all of the following:

(1) The name and address of the applicant and the manufacturer or distributor.

(2) The make of motor vehicle or towable recreational vehicle that the applicant is authorized to sell.

(3) The applicant's area of responsibility as stipulated in the franchise and certified on a form prescribed by the department.

(4) The signature of the manufacturer or distributor.

*c.* Nothing in this subrule shall be construed to require a franchise agreement from a final-stage manufacturer applying for a motor vehicle dealer license under rule 761—425.11(322).

**425.10(4) Corporate applicants.** If the applicant is a corporation, the applicant shall certify on the application that the corporation complies with all applicable state requirements for incorporation.

**425.10(5) Principal place of business.** The applicant shall maintain a principal place of business, which must be staffed during regular business hours. See rules 761—425.12(322) and 761—425.14(322) for further requirements.

**425.10(6) Zoning.** The applicant shall provide to the vehicle and motor carrier services bureau written evidence, issued by the office responsible for the enforcement of zoning ordinances in the city or county where the applicant's business is located, which states that the applicant's principal place of business and any extensions comply with all applicable zoning provisions or are a legal nonconforming use.

**425.10(7) Separate licenses required.**

*a.* A separate license is required for each city or township in which an applicant for a motor vehicle dealer's license maintains a place of business.

*b.* A separate license is required for each county in which an applicant for a towable recreational vehicle dealer's license maintains a place of business.

**425.10(8) *Financial liability.*** The applicant for a motor vehicle dealer's license shall certify on the application that the applicant has the required financial liability coverage in the limits as set forth in Iowa Code subsection 322.4(1). It is the applicant's responsibility to ensure the required financial liability coverage is continuous with no lapse in coverage as long as the applicant maintains a valid dealer's license.

**425.10(9) *Ownership information.***

*a.* If the owner of the business is an individual, the application shall include the legal name, bona fide address, and telephone number of the individual. If the owner is a partnership, the application shall include the legal name, bona fide address, and telephone number of two partners. If the owner is a corporation, the application shall include the legal name, bona fide address, and telephone number of two corporate officers. In all cases, the telephone number must be a number where the individual, partner, or corporate officer can be reached during normal business hours.

*b.* The application shall include the federal employer identification number of the business. However, if the business is owned by an individual who is not required to have a federal employer identification number, the application shall include the individual's social security number, Iowa nonoperator's identification number or Iowa driver's license number.

**425.10(10) Reserved.**

**425.10(11) *Verification of compliance.*** The department shall verify the applicant's compliance with all statutory and regulatory dealer licensing requirements.

This rule is intended to implement Iowa Code sections 322.1 to 322.15 and 322C.1 to 322C.6.

[ARC 9048B, IAB 9/8/10, effective 10/13/10; ARC 3687C, IAB 3/14/18, effective 4/18/18; ARC 4343C, IAB 3/13/19, effective 4/17/19; ARC 4960C, IAB 3/11/20, effective 4/15/20]

#### **761—425.11(322) Motor vehicle dealer licensing for final-stage manufacturers.**

**425.11(1) *Eligibility.*** A final-stage manufacturer may be licensed as a motor vehicle dealer if the final-stage manufacturer:

- a.* Meets the definition of "final-stage manufacturer" in Iowa Code section 322.2.
- b.* Meets the requirements of a final-stage manufacturer in 49 CFR Section 567.5.
- c.* Is licensed as a manufacturer under Iowa Code chapter 322 and this chapter.

**425.11(2) *Application.*** A final-stage manufacturer shall apply for a motor vehicle dealer license in the manner described in rule 761—425.10(322) and shall certify that the final-stage manufacturer meets the eligibility requirements under subrule 425.11(1).

This rule is intended to implement Iowa Code sections 322.2 and 322.3.

[ARC 4343C, IAB 3/13/19, effective 4/17/19]

#### **761—425.12(322) Motor vehicle dealer's principal place of business.**

**425.12(1) *Verification of compliance.*** Before a motor vehicle dealer's license is issued, a representative of the department may physically inspect an applicant's principal place of business to verify compliance with this rule.

**425.12(2) *Telephone service and office area.*** A motor vehicle dealer's principal place of business shall include telephone service and an adequate office area, separate from other facilities, for keeping business records, manufacturers' certificates of origin, certificates of title or other evidence of ownership for all motor vehicles offered for sale. Telephone service must be a land line and not cellular phone service. Evidence of ownership may include a copy of an original document if the original document is held by a lienholder.

**425.12(3) *Facility for displaying motor vehicles.*** A motor vehicle dealer's principal place of business shall include a suitable space reserved for display purposes where motor vehicles may be viewed by prospective buyers. The facility shall be:

*a.* Within a building. EXCEPTION: For used motor vehicle dealers and for dealers selling new trucks or motor homes exclusively, the display facility may be an outdoor area with an all-weather surface. An all-weather surface does not include grass or exposed soil.

*b.* Of a minimum size.

(1) For display of motorcycles, motorized bicycles and autocycles, the minimum size of the display facility is 10 feet by 15 feet.

(2) For display of other motor vehicles, the minimum size of the display facility is 18 feet by 30 feet.

**425.12(4) *Facility for reconditioning and repairing motor vehicles.*** A motor vehicle dealer's principal place of business shall include a facility for reconditioning and repairing motor vehicles. The facility shall be an area that:

- a.* Is equipped to repair and recondition one or more motor vehicles of a type sold by the dealer.
- b.* Is within a building.
- c.* Has adequate access.

- d. Is separated from the display and office areas by solid, floor-to-ceiling walls and solid, full-length doors.
- e. Is of a minimum size.

(1) The minimum size facility for motorcycles, motorized bicycles and autocycles is an unobstructed rectangular area measuring 10 feet by 15 feet.

(2) The minimum size facility for other types of motor vehicles is an unobstructed rectangular area measuring 14 feet by 24 feet.

**425.12(5) *Motor vehicle dealer who is also a recycler.*** If a motor vehicle dealer also does business as a recycler, there shall be separate parking for motor vehicles being offered for sale at retail from motor vehicles that are salvage.

This rule is intended to implement Iowa Code sections 322.1 to 322.15.

[ARC 9048B, IAB 9/8/10, effective 10/13/10; ARC 0778C, IAB 6/12/13, effective 7/17/13; ARC 2985C, IAB 3/15/17, effective 4/19/17; ARC 4343C, IAB 3/13/19, effective 4/17/19]

**761—425.13(321,322) Business records of a motor vehicle dealer with multiple licenses.**

**425.13(1) *Applicability.*** A motor vehicle dealer licensed under Iowa Code chapter 322 and this chapter who holds more than one motor vehicle dealer license may maintain the dealer's collective business records together at any of the dealer's licensed locations.

**425.13(2) *Separation of records.*** Business records of licensed motor vehicle dealers kept at a single licensed location under this rule shall be stored separately and distinctly, in a manner distinguishable to each licensee, and shall not be commingled.

**425.13(3) *Notification to the department.*** A motor vehicle dealer shall notify the vehicle and motor carrier services bureau in writing no fewer than ten days before moving the dealer's business records to another licensed location.

This rule is intended to implement Iowa Code sections 321.63 and 322.2 to 322.15.

[ARC 4343C, IAB 3/13/19, effective 4/17/19; ARC 4960C, IAB 3/11/20, effective 4/15/20]

**761—425.14(322) Towable recreational vehicle dealer's place of business.**

**425.14(1) *Telephone service and office area.*** A towable recreational vehicle dealer's principal place of business shall include telephone service and an adequate office area, separate from other facilities, for keeping business records, manufacturers' certificates of origin, certificates of title or other evidence of ownership for all towable recreational vehicles offered for sale. Telephone service must be a land line and not cellular phone service. Evidence of ownership may include a copy of an original document if the original document is held by a lienholder.

**425.14(2) *Facility for displaying towable recreational vehicles.*** A towable recreational vehicle dealer's principal place of business shall include a space of sufficient size to permit the display of one or more towable recreational vehicles. The display facility may be an indoor area or an outdoor area with an all-weather surface. An all-weather surface does not include grass or exposed soil. If an outdoor display facility is maintained, it may be used only to display, recondition or repair towable recreational vehicles or to park vehicles.

**425.14(3) *Facility for repairing and reconditioning towable recreational vehicles.*** A towable recreational vehicle dealer's principal place of business shall include a facility for reconditioning and repairing towable recreational vehicles. The facility:

- a. Shall be equipped and of sufficient size to repair and recondition one or more towable recreational vehicles of a type sold by the dealer.
- b. Shall have adequate access.
- c. May be an indoor area or an outdoor area with an all-weather surface. An all-weather surface does not include grass or exposed soil.
- d. May occupy the same area as the display facility.

**425.14(4) *Towable recreational vehicle dealer also licensed as a motor vehicle dealer.*** If a towable recreational vehicle dealer is also licensed as a motor vehicle dealer under the same name and at the same principal place of business, separate facilities for displaying, repairing and reconditioning towable recreational vehicles are not required.

This rule is intended to implement Iowa Code sections 322C.1 to 322C.6.

[ARC 4960C, IAB 3/11/20, effective 4/15/20]

**761—425.15 and 425.16** Reserved.

**761—425.17(322) Extension lot license.** Extension lots of motor vehicle and towable recreational vehicle dealers must be licensed. Application to license an extension lot shall be made on a form prescribed by the department.

**425.17(1)** For a motor vehicle dealer, an extension lot is a car lot for the sale of motor vehicles that is located within the same city or township as, but is not adjacent to, the motor vehicle dealer's principal place of business.

**425.17(2)** For a towable recreational vehicle dealer, an extension lot is a towable recreational vehicle lot for the sale of towable recreational vehicles that is located within the same county as, but is not adjacent to, the towable recreational vehicle dealer's principal place of business.

**425.17(3)** An extension lot must be owned or leased by the dealer.

**425.17(4)** Parcels of property are adjacent if the parcels are owned or leased by the dealer and the parcels are either adjoining or are separated only by an alley, street or highway that is not a fully controlled access facility.

This rule is intended to implement Iowa Code sections 322.1 to 322.15 and 322C.1 to 322C.6.

[ARC 4960C, IAB 3/11/20, effective 4/15/20]

**761—425.18(322) Supplemental statement of changes.** A motor vehicle dealer shall file a written statement with the vehicle and motor carrier services bureau at least ten days before any change of name, location, hours, or method or plan of doing business. A license is not valid until the changes listed in the statement have been approved by the vehicle and motor carrier services bureau.

This rule is intended to implement Iowa Code sections 322.1 to 322.15.

[ARC 3687C, IAB 3/14/18, effective 4/18/18; ARC 4960C, IAB 3/11/20, effective 4/15/20]

**761—425.19** Reserved.

**761—425.20(322) Fleet vehicle sales and retail auction sales.**

**425.20(1) Fleet sales.** Any person who has acquired vehicles for consumer use in a business shall obtain the appropriate dealer's license when more than six vehicles are offered for sale at retail in a 12-month period.

**425.20(2) Retail auction sales.** Any person who sells at public auction more than six vehicles in a 12-month period shall obtain the appropriate dealer's license. All certificates of title for the vehicles offered for sale at public auction shall be duly assigned to the dealer.

**425.20(3) Place of business.** A dealer's license issued under this rule does not require a place of business.

**425.20(4) Exceptions.**

a. The state of Iowa, counties, cities and other governmental subdivisions are not required to obtain a dealer's license to sell their vehicles at retail.

b. This rule does not apply to a vehicle owner, or to an auctioneer representing the owner, selling vehicles at a retail auction if the vehicles were acquired by the owner for consumer use, the vehicles are incidental to the auction, and only one owner's vehicles are sold.

This rule is intended to implement Iowa Code sections 322.1 to 322.15 and 322C.1 to 322C.6.

**761—425.21 to 425.23** Reserved.

**761—425.24(322) Miscellaneous requirements.**

**425.24(1)** The department shall not issue a license under Iowa Code chapter 322 or 322C to any other person at a principal place of business of a person currently licensed under Iowa Code chapter 322 or 322C.

**425.24(2)** A motor vehicle or towable recreational vehicle dealer shall not represent or advertise the dealership under any name or style other than the name which appears on the dealer's license.

**425.24(3)** Other business activities are allowed at a place of business of a dealer, but those activities shall not include the sale of firearms, dangerous weapons as defined in Iowa Code section 702.7, or alcoholic beverages as defined in Iowa Code subsection 123.3(4).

This rule is intended to implement Iowa Code sections 322.1 to 322.15 and 322C.1 to 322C.6.

[ARC 9048B, IAB 9/8/10, effective 10/13/10; ARC 4960C, IAB 3/11/20, effective 4/15/20]

**761—425.25** Reserved.

**761—425.26(322) State fair, fairs, shows and exhibitions.**

**425.26(1) Definitions.** As used in this rule:

"Community" means an area of responsibility as defined in Iowa Code section 322A.1.

"Display" means having new motor vehicles or new towable recreational vehicles available for public viewing at fairs, vehicle shows or vehicle exhibitions. The dealer may also post, display or provide product information through literature or other descriptive media. However, the product information shall not include prices, except for the manufacturer's sticker price. "Display" does not mean offering new vehicles for sale or negotiating sales of new vehicles.

“Fair” means a county fair or a scheduled gathering for a predetermined period of time at a specific location for the exhibition, display or sale of various wares, products, equipment, produce or livestock, but not solely new vehicles, and sponsored by a person other than a single dealer.

“Offer” new vehicles “for sale,” “negotiate sales” of new vehicles, or similar wording, means doing any of the following at the state fair or a fair, vehicle show or vehicle exhibition: posting prices in addition to the manufacturer’s sticker price, discussing prices or trade-ins, arranging for payments or financing, and initiating contracts.

“State fair” means the fair as discussed in Iowa Code chapter 173.

“Vehicle exhibition” means a scheduled event conducted at a specific location where various types, makes or models of new vehicles are displayed either at the same time or consecutively in time, and sponsored by a person other than a single dealer.

“Vehicle show” means a scheduled event conducted for a predetermined period of time at a specific location for the purpose of displaying at the same time various types, makes or models of new vehicles, which may be in conjunction with other events or displays, and sponsored by a person other than a single dealer.

**425.26(2) Permits for dealers of new motor vehicles.**

a. A “display only” fair, vehicle show or vehicle exhibition permit allows a motor vehicle dealer to display new motor vehicles at a specified fair, vehicle show or vehicle exhibition in any Iowa county. The permit is valid on Sundays.

b. A “full” fair, state fair, vehicle show or vehicle exhibition permit allows a motor vehicle dealer to display and offer new motor vehicles for sale and negotiate sales of new motor vehicles at the state fair, or a specified fair, vehicle show or vehicle exhibition that is held within the motor vehicle dealer’s community. EXCEPTION: A motor vehicle dealer who is licensed to sell motor homes may be issued a permit to offer for sale Class “A” and Class “C” motor homes at a specified fair, vehicle show or vehicle exhibition in any Iowa county. A “full” fair, show or exhibition permit is not valid on Sundays.

c. The following restrictions are applicable to both types of permits:

(1) Permits will be issued to motor vehicle dealers only for the state fair, fairs, vehicle shows or vehicle exhibitions where more than one motor vehicle dealer may participate.

(2) A permit is limited to the line makes for which the motor vehicle dealer is licensed in Iowa.

**425.26(3) Reserved.**

**425.26(4) Permits for dealers of new towable recreational vehicles.** A fair, vehicle show or vehicle exhibition permit allows a towable recreational vehicle dealer to display and offer new towable recreational vehicles for sale and negotiate sales of new towable recreational vehicles at a specified fair, vehicle show, or vehicle exhibition in any Iowa county.

a. The permit is valid on Sundays.

b. The permit is limited to the line makes for which the towable recreational vehicle dealer is licensed in Iowa.

c. A towable recreational vehicle dealer who does not have a permit may display vehicles at fairs, vehicle shows and vehicle exhibitions.

**425.26(5) Permit application.** A motor vehicle or towable recreational vehicle dealer shall apply for a permit on an application form prescribed by the department. The application shall include the dealer’s name, address and license number and the following information about the event: name, location, sponsor(s) and duration, including the opening and closing dates.

**425.26(6) Display of permit.** The motor vehicle or towable recreational vehicle dealer shall display the permit in close proximity to the vehicles being exhibited.

This rule is intended to implement Iowa Code sections 322.5(2) and 322C.3(9).

[ARC 3687C, IAB 3/14/18, effective 4/18/18; ARC 4960C, IAB 3/11/20, effective 4/15/20]

**761—425.27 and 425.28** Reserved.

**761—425.29(322) Classic car permit.** A classic car permit allows a motor vehicle dealer to display and sell classic cars at a specified county fair, vehicle show or vehicle exhibition that is held in the same county as the motor vehicle dealer’s principal place of business. “Classic car” is defined in Iowa Code subsection 322.5(3).

**425.29(1)** The permit period is the duration of the event, not to exceed five days. The permit is valid on Sundays. Only one permit may be issued to each motor vehicle dealer for an event. No more than three permits may be issued to a motor vehicle dealer in any one calendar year.

**425.29(2)** Application for a classic car permit shall be made on a form prescribed by the department. The application shall include the dealer’s name, address and license number and the following information about the

county fair, vehicle show or vehicle exhibition: name, location, sponsor(s) and duration, including the opening and closing dates.

**425.29(3)** The motor vehicle dealer shall display the permit in a prominent place at the location of the county fair, vehicle show or vehicle exhibition.

This rule is intended to implement Iowa Code subsection 322.5(3).

**761—425.30(322) Motor truck display permit.** Application for a permit under Iowa Code subsection 322.5(4) shall be made on a form prescribed by the department. The application shall include information or documentation showing that the nonresident motor vehicle dealer is eligible for issuance of a permit and that the event meets the statutory conditions for permit issuance.

This rule is intended to implement Iowa Code subsection 322.5(4).

**761—425.31(322) Firefighting and rescue show permit.**

**425.31(1)** Application for a firefighting and rescue show permit shall be made on a form prescribed by the department. The application shall include the name, address and license number of the applicant, the type of vehicles being displayed, and the following information about the vehicle show or vehicle exhibition: name, location, sponsor(s), and duration, including the opening and closing dates.

**425.31(2)** The permit is not valid on Sundays. Only one permit shall be issued to each licensee for an event.

**425.31(3)** The permit holder shall display the permit in a prominent place at the location of the vehicle show or vehicle exhibition.

This rule is intended to implement Iowa Code section 322.5(5).

[ARC 9048B, IAB 9/8/10, effective 10/13/10; ARC 3687C, IAB 3/14/18, effective 4/18/18]

**761—425.32 to 425.39** Reserved.

**761—425.40(322) Salespersons of dealers.**

**425.40(1)** Every motor vehicle and towable recreational vehicle dealer shall:

*a.* Keep a current written record of all salespersons acting in its behalf. The record shall be open to inspection by any peace officer or any employee of the department.

*b.* Maintain a current record of authorized persons allowed to sign all documents required under Iowa Code chapter 321 for vehicle sales.

**425.40(2)** No person shall either directly or indirectly claim to represent a dealer unless the person is listed as a salesperson by that dealer.

This rule is intended to implement Iowa Code sections 322.3, 322.13, and 322C.4.

[ARC 4960C, IAB 3/11/20, effective 4/15/20]

**761—425.41 to 425.49** Reserved.

**761—425.50(322) Manufacturers, distributors, and wholesalers.** This rule applies to the licensing of manufacturers, distributors, and wholesalers of new motor vehicles and towable recreational vehicles.

**425.50(1)** *Application for license.* To apply for a license, the applicant shall complete an application form prescribed by the department. A list of the applicant's franchised dealers in Iowa and a sample copy of a completed manufacturer's certificate of origin that is issued by the firm shall accompany the application. A distributor or wholesaler shall also provide a copy of written authorization from the manufacturer to act as its distributor or wholesaler.

**425.50(2)** *Licensing requirements.*

*a.* New motor homes delivered to Iowa dealers must contain the systems and meet the standards specified in Iowa Code section 321.1(36C)"d."

*b.* A licensee shall ensure that any new retail outlet is properly licensed as a dealer before any vehicles are delivered to the outlet.

*c.* A licensee shall notify the vehicle and motor carrier services bureau in writing at least ten days prior to any:

(1) Change in name, location or method of doing business, as shown on the license.

(2) Issuance of a franchise to a dealer in this state to sell new vehicles at retail.

(3) Change in the trade name of a towable recreational vehicle manufactured for delivery in this state.

*d.* A licensee shall notify the vehicle and motor carrier services bureau in writing at least ten days before any new make of vehicle is offered for sale at retail in this state.

This rule is intended to implement Iowa Code sections 322.27 to 322.30 and 322C.7 to 322C.9.

[ARC 3687C, IAB 3/14/18, effective 4/18/18; ARC 4960C, IAB 3/11/20, effective 4/15/20]

**761—425.51(322) Factory or distributor representatives.** Rescinded IAB 11/3/99, effective 12/8/99.

**761—425.52(322) Used vehicle wholesalers.** Rescinded IAB 11/7/07, effective 12/12/07.

**761—425.53(322) Wholesaler's financial liability coverage.** A new motor vehicle wholesaler shall certify on the license application that it has the required financial liability coverage in the limits set forth in Iowa Code section 322.27A. It is the wholesaler's responsibility to ensure that the required financial liability coverage is continuous with no lapse in coverage as long as the wholesaler maintains a valid wholesaler's license.

This rule is intended to implement Iowa Code section 322.27A.

**761—425.54 to 425.59** Reserved.

**761—425.60(322) Right of inspection.**

**425.60(1)** Peace officers have the authority to inspect vehicles or component parts of vehicles, business records, and manufacturers' certificates of origin, certificates of title and other evidence of ownership for all vehicles offered for sale.

**425.60(2)** The department has the right at any time to verify compliance of a person licensed under Iowa Code chapter 322 or 322C or issued a certificate under Iowa Code section 321.59 with all statutory and regulatory requirements.

This rule is intended to implement Iowa Code sections 321.62, 321.95, 322.13, and 322C.1.

**761—425.61** Reserved.

**761—425.62(322) Denial, suspension or revocation.**

**425.62(1)** The department may deny an application or suspend or revoke a certificate or license if the applicant, certificate holder or licensee fails to comply with the applicable provisions of this chapter of rules, Iowa Code sections 321.57 to 321.63 or Iowa Code chapter 322 or 322C.

**425.62(2)** The department may deny a dealer's application for the state fair or a fair, vehicle show or vehicle exhibition permit for a period not to exceed six months if the dealer fails to comply with the applicable provisions of rule 761—425.26(322) or Iowa Code section 322.5(2) or 322C.3(9).

**425.62(3)** The department may deny a motor vehicle dealer's application for a demonstration permit for a period not to exceed six months if the dealer fails to comply with rule 761—425.72(321).

**425.62(4)** The department shall send notice by certified mail to a person whose certificate, license or permit is to be revoked, suspended, canceled or denied. The notice shall be mailed to the person's mailing address as shown on departmental records or, if the person is currently licensed, to the principal place of business, and shall become effective 20 days from the date mailed. A person who is aggrieved by a decision of the department and who is entitled to a hearing may contest the decision in accordance with 761—Chapter 13. The request shall be submitted in writing to the director of the vehicle and motor carrier services bureau at the address in subrule 425.1(2). The request shall be deemed timely submitted if it is delivered or postmarked on or before the effective date specified in the notice of revocation, suspension, cancellation or denial.

This rule is intended to implement Iowa Code chapter 17A and sections 321.57 to 321.63, 322.6, 322.9, 322.31, and 322C.6.

[ARC 9048B, IAB 9/8/10, effective 10/13/10; ARC 3687C, IAB 3/14/18, effective 4/18/18; ARC 4960C, IAB 3/11/20, effective 4/15/20]

**761—425.63 to 425.69** Reserved.

**761—425.70(321) Dealer plates.**

**425.70(1)** *Definition.* The definitions of "dealer" and "vehicle" in Iowa Code section 321.1 apply to this rule.

**425.70(2)** *Persons who may be issued dealer plates.* Dealer plates as provided in Iowa Code sections 321.57 to 321.63 may be issued to:

a. Licensed motor vehicle dealers.

b. Licensed towable recreational vehicle dealers.

c. A person engaged in the business of buying, selling or exchanging trailer-type vehicles subject to registration under Iowa Code chapter 321, other than towable recreational vehicles, and who has an established place of business for such purpose in this state.

*d.* Insurers selling vehicles of a type subject to registration under Iowa Code chapter 321 solely for the purpose of disposing of vehicles acquired as a result of a damage settlement or recovered stolen vehicles acquired as a result of a loss settlement. The plates shall display the words “limited use.”

*e.* Persons selling vehicles of a type subject to registration under Iowa Code chapter 321 solely for the purpose of disposing of vehicles acquired or repossessed by them in exercise of powers or rights granted by lien or title-retention instruments or contracts given as security for loans or purchase money obligations, and who are not required to be licensed dealers. The plates shall display the words “limited use.”

*f.* Persons engaged in the business of selling special equipment body units which have been or will be installed on motor vehicle chassis not owned by them, solely for the purpose of delivering, testing or demonstrating the special equipment body and the motor vehicle. The plates shall display the words “limited use.”

*g.* A licensed manufacturer of ambulances, rescue vehicles or fire vehicles, solely for the purpose of transporting, demonstrating, showing or exhibiting the vehicles. The plates shall display the words “limited use.”

*h.* A licensed wholesaler who is also licensed as a motor vehicle dealer as specified in paragraph 425.70(3) “e.”

**425.70(3) Use of dealer plates.**

*a.* Dealer plates shall not be displayed on vehicles that are rented or loaned. However, a dealer plate may be displayed on a motor vehicle, other than a truck or truck tractor, loaned to a customer of a licensed motor vehicle dealer while the customer’s motor vehicle is being serviced or repaired by the dealer.

*b.* Saddle-mounted vehicles being transported shall display dealer plates.

*c.* Dealer plates may be displayed on a trailer carrying a load, provided the motor vehicle towing the trailer is properly registered under Iowa Code section 321.109, 321.120, or 321.122, or is displaying a dealer plate described in paragraph 425.70(3) “e,” or a demonstration permit has been issued as described in rule 761—425.72(321).

*d.* Dealer plates may be used by a dealer licensed as a wholesaler for a new motor vehicle model when operating a new motor vehicle of that model if the motor vehicle is owned by the wholesaler and is operated solely for the purpose of demonstration, show or exhibition.

*e.* A dealer plate issued under Iowa Code section 321.60 for the purpose of hauling a load or towing a trailer shall be marked “HAUL & TOW.” Dealer “HAUL & TOW” plates may only be displayed on vehicles in the dealer’s inventory that are continuously offered for sale at retail.

This rule is intended to implement Iowa Code sections 321.57 to 321.63.

[ARC 3687C, IAB 3/14/18, effective 4/18/18; ARC 4960C, IAB 3/11/20, effective 4/15/20]

**761—425.71** Reserved.

**761—425.72(321) Demonstration permits.**

**425.72(1)** Demonstration permits may be issued by motor vehicle dealers to permit the use of dealer plates for the purpose of demonstrating the load capabilities of motor trucks and truck tractors. A demonstration permit must be issued on a form prescribed by the department.

**425.72(2)** The dealer shall complete the permit. The information to be filled out includes, but is not limited to, the following:

*a.* Date of issuance by the dealer, date of expiration, and the specific dates for which the permit is valid. The expiration date shall be five days or less from the date of issuance.

*b.* Dealer’s name, address and license number.

*c.* Name(s) of the prospective buyer(s) and all prospective drivers.

*d.* Route of the demonstration trip. The points of origin and destination shall be the dealership. The permit is not valid for a route outside Iowa.

*e.* The make, year and vehicle identification number of the motor vehicle being demonstrated.

**425.72(3)** The permit shall at all times be carried in the motor vehicle to which it refers and shall be shown to any peace officer upon request.

**425.72(4)** Only one demonstration permit per motor vehicle shall be issued for a prospective buyer.

**425.72(5)** The demonstration permit is valid only for a movement that does not exceed the legal length, width, height and weight restrictions. The permit is not valid for an overdimensional or overweight movement.

**425.72(6)** A dealer plate issued under Iowa Code section 321.60 for the purpose of hauling a load or towing a trailer may be used in lieu of a demonstration permit.

This rule is intended to implement Iowa Code sections 321.57 to 321.63.

[ARC 3687C, IAB 3/14/18, effective 4/18/18]

[761—Chapter 420 appeared as Ch 10, Department of Public Safety, 1973 IDR]

[Filed 7/1/75]

[Filed 10/28/77, Notice 8/24/77—published 11/16/77, effective 12/21/77]  
[Filed 11/22/77, Notice 10/5/77—published 12/14/77, effective 1/18/78]  
[Filed 5/9/78, Notice 3/22/78—published 5/31/78, effective 7/5/78]  
[Filed 10/10/78, Notice 8/23/78—published 11/1/78, effective 12/6/78]  
[Filed 8/23/79, Notice 7/11/79—published 9/19/79, effective 10/24/79]  
[Filed 2/14/80, Notice 12/26/79—published 3/5/80, effective 4/9/80]  
[Filed 9/9/81, Notice 7/22/81—published 9/30/81, effective 11/4/81]  
[Filed 1/28/82, Notice 12/9/81—published 2/17/82, effective 3/24/82]  
[Filed 1/21/83, Notice 12/8/82—published 2/16/83, effective 3/23/83]  
[Filed emergency 2/17/83—published 3/16/83, effective 3/23/83]  
[Filed 9/4/85, Notice 7/17/85—published 9/25/85, effective 10/30/85]  
[Filed emergency 10/23/86—published 11/19/86, effective 10/24/86]  
[Filed 1/6/87, Notice 11/19/86—published 1/28/87, effective 3/4/87]  
[Filed 5/11/87, Notice 3/11/87—published 6/3/87, effective 7/8/87]  
[Filed 11/3/88, Notice 9/21/88—published 11/30/88, effective 1/4/89]<sup>o</sup>  
[Filed emergency 11/30/89—published 12/27/89, effective 12/1/89]  
[Filed 12/5/90, Notice 10/17/90—published 12/26/90, effective 1/30/91]  
[Filed 1/15/92, Notice 12/11/91—published 2/5/92, effective 3/11/92]  
[Filed 1/14/93, Notice 11/25/92—published 2/3/93, effective 3/10/93]  
[Filed 12/16/93, Notice 11/10/93—published 1/5/94, effective 2/9/94]  
[Filed 6/19/96, Notice 1/17/96—published 7/17/96, effective 8/21/96]  
[Filed 3/5/97, Notice 1/29/97—published 3/26/97, effective 4/30/97]  
[Filed 12/17/97, Notice 11/5/97—published 1/14/98, effective 2/18/98]  
[Filed 10/14/99, Notice 9/8/99—published 11/3/99, effective 12/8/99]  
[Filed 7/20/00, Notice 6/14/00—published 8/9/00, effective 9/13/00]  
[Filed 6/19/02, Notice 4/17/02—published 7/10/02, effective 8/14/02]  
[Filed 11/2/05, Notice 9/14/05—published 11/23/05, effective 12/28/05]  
[Filed 10/11/07, Notice 8/15/07—published 11/7/07, effective 12/12/07]  
[Filed ARC 9048B (Notice ARC 8869B, IAB 6/30/10), IAB 9/8/10, effective 10/13/10]  
[Filed ARC 0136C (Notice ARC 0068C, IAB 4/4/12), IAB 5/30/12, effective 7/4/12]  
[Filed ARC 0778C (Notice ARC 0658C, IAB 4/3/13), IAB 6/12/13, effective 7/17/13]  
[Filed ARC 2985C (Notice ARC 2908C, IAB 1/18/17), IAB 3/15/17, effective 4/19/17]  
[Filed ARC 3687C (Notice ARC 3513C, IAB 12/20/17), IAB 3/14/18, effective 4/18/18]  
[Filed ARC 4343C (Notice ARC 4230C, IAB 1/16/19), IAB 3/13/19, effective 4/17/19]  
[Filed ARC 4960C (Notice ARC 4770C, IAB 11/20/19), IAB 3/11/20, effective 4/15/20]

<sup>o</sup> Two or more ARCs

CHAPTERS 426 to 429  
Reserved



CHAPTER 430  
MOTOR VEHICLE LEASING LICENSES  
[Prior to 6/3/87, Transportation Department[820]—(07,D)Ch9]

**761—430.1(321F) General.**

**430.1(1) Information.** Information and blank forms relating to this chapter may be obtained from the Motor Vehicle Division, Iowa Department of Transportation, by mail at P.O. Box 9278, Des Moines, Iowa 50306-9278; by telephone at (515)237-3110; by email at [vcusto@iowadot.us](mailto:vcusto@iowadot.us); or from the department's website at [www.iowadot.gov](http://www.iowadot.gov). Completed forms shall be submitted to the Motor Vehicle Division, Iowa Department of Transportation, by mail at P.O. Box 9278, Des Moines, Iowa 50306-9278.

**430.1(2) Definition.** “Engage in the business” means leasing two or more motor vehicles that are subject to registration in a 12-month period if the lessee is a resident of this state and first takes possession of the vehicle in this state, or if the lessor's business address is located in this state. A person shall not be considered to be engaged in the business if the business address is located outside of this state and the lessee first takes possession of the motor vehicle outside of this state.

[ARC 2755C, IAB 10/12/16, effective 11/16/16; ARC 6490C, IAB 9/7/22, effective 10/12/22]

**761—430.2(321F) Application.** Application for a motor vehicle leasing license shall be made on a form prescribed by the department.

**430.2(1)** The application shall include the name, bona fide business address, and telephone number under which the applicant will conduct the business of leasing motor vehicles for use by others for compensation.

**430.2(2)** If the owner of the business is an individual, the application shall include the legal name, bona fide address, and telephone number of the individual. If the owner is a partnership, the application shall include the legal name, bona fide address, and telephone number of two partners. If the owner is a corporation, the application shall include the legal name, bona fide address, and telephone number of two corporate officers. In all cases, the telephone number must be a number where the individual, partner, or corporate officer can be reached during normal business hours.

**430.2(3)** The application shall include the federal employer identification number of the business. However, if the business is owned by an individual who is not required to have a federal employer identification number, the application shall include the individual's social security number, Iowa nonoperator's identification number or Iowa driver's license number.

**761—430.3(321F) Supplemental statements.** The licensee shall notify the department, in writing, within ten days, at the address shown in subrule 430.1(1), of any change in the information required on the original application.

**761—430.4(321F) Separate licenses required.** A separate license is required for:

**430.4(1)** Each address under which a single business entity will conduct business under Iowa Code chapter 321F and these rules.

**430.4(2)** Each address that will be used for titling or registering vehicles subject to registration in Iowa. These rules are intended to implement Iowa Code chapter 321F.

[761—Chapter 430 appeared as Ch 6, Department of Public Safety, January 1975 Supplement]

[Filed 10/28/77, Notice 8/24/77—published 11/16/77, effective 12/21/77]

[Filed 9/9/81, Notice 7/22/81—published 9/30/81, effective 11/4/81]

[Filed 5/11/87, Notice 3/11/87—published 6/3/87, effective 7/8/87]

[Filed emergency 11/30/89—published 12/27/89, effective 12/1/89]

[Filed 11/29/95, Notice 10/25/95—published 12/20/95, effective 1/24/96]

[Filed 10/11/07, Notice 8/15/07—published 11/7/07, effective 12/12/07]

[Filed ARC 2755C (Notice ARC 2640C, IAB 8/3/16), IAB 10/12/16, effective 11/16/16]

[Filed ARC 6490C (Notice ARC 6342C, IAB 6/1/22), IAB 9/7/22, effective 10/12/22]



CHAPTER 431  
VEHICLE RECYCLERS

[Prior to 6/3/87, Transportation Department[820]—(07.D)Ch 6]

**761—431.1(321H) General.**

**431.1(1) Information.** Information and blank forms relating to this chapter may be obtained from and completed forms shall be submitted to the Motor Vehicle Division, Iowa Department of Transportation, P.O. Box 9278, Des Moines, Iowa 50306-9278. Information and forms are also available on the department's website at [www.iowadot.gov](http://www.iowadot.gov).

**431.1(2) Definitions.**

"Principal place of business" means a building actually occupied where the public and the department may contact the owner or operator during regular business hours.

"Regular business hours" means to be consistently open to the public on a weekly basis at hours reported to the motor vehicle division. Regular business hours shall include a minimum of 32 posted hours between 7 a.m. and 9 p.m., Monday through Friday.

This rule is intended to implement Iowa Code sections 321H.2 and 321H.4.

[ARC 9048B, IAB 9/8/10, effective 10/13/10; ARC 0136C, IAB 5/30/12, effective 7/4/12; ARC 6489C, IAB 9/7/22, effective 10/12/22]

**761—431.2(321H) Criteria for a vehicle recycler license.**

**431.2(1) General qualifications.** Every authorized vehicle recycler shall:

a. Maintain regular business hours and telephone service at the principal place of business which shall include separate and adequate office space for the recycler's business records. Telephone service must be a land line and not cellular phone service.

b. Comply with local zoning laws.

c. Comply with the provisions of Iowa Code chapter 306C, relating to the Iowa junkyard control law, when applicable.

d. If subject to the requirements of 28 CFR Section 25.56, as adopted in Iowa Code section 321H.4A(2) "a," do all of the following:

(1) Obtain and maintain a registered account with the National Motor Vehicle Title Information System (NMVTIS).

(2) Report, or verify reporting of, inventory to the NMVTIS.

(3) If applicable, verify the seller of a vehicle purchased by the recycler has complied with 28 CFR Section 25.56 and document such verification on a form prescribed by the department if third-party electronic records are insufficient to verify compliance with 28 CFR Section 25.56 because the vehicle has been crushed or flattened by mechanical means, as stated in Iowa Code section 321H.4A.

(4) Retain records of compliance, including verification forms completed under subparagraph 431.2(1) "d"(3), at the vehicle recycler's principal place of business for at least three years after the purchase of the vehicle. Records may be stored either in hard copy or electronically. Records of compliance shall be open for inspection by any peace officer during normal business hours.

**431.2(2) Vehicle rebuilder qualifications.** For every licensed location, a vehicle rebuilder must have:

a. An unobstructed area inside a building for rebuilding and restoring vehicles. The inside measurement of the unobstructed area must be at least 14 feet by 24 feet.

b. Sufficient storage for all vehicles in the rebuilder's inventory.

c. Equipment necessary to perform rebuilding and restoring of vehicles in the inventory, such as frame-straightening equipment, a hydraulic jack, alignment and calibration equipment, and tools.

**431.2(3) Used vehicle parts dealer qualifications.** For every licensed location, a used vehicle parts dealer must have sufficient storage for the vehicle parts in the dealer's inventory.

**431.2(4) Vehicle salvager qualifications.** For every licensed location, a vehicle salvager must have:

a. Sufficient storage for vehicles, vehicle parts, and vehicle bodies included in the salvager's inventory.

b. Sufficient equipment necessary to perform dismantling, scrapping or storing of vehicles and vehicle parts in the inventory.

This rule is intended to implement Iowa Code sections 321H.4 and 321H.4A.

[ARC 9048B, IAB 9/8/10, effective 10/13/10; ARC 6489C, IAB 9/7/22, effective 10/12/22]

**761—431.3(321H) Application.** The application for a vehicle recycler's license shall be made on a form prescribed by the department.

**431.3(1)** The application shall include the name, bona fide business address, and telephone number under which the applicant will conduct business as an authorized vehicle recycler.

**431.3(2)** If the owner of the business is an individual, the application shall include the legal name, bona fide address, and telephone number of the individual. If the owner is a partnership, the application shall include the legal name, bona fide address, and telephone number of two partners. If the owner is a corporation, the application shall include the legal name, bona fide address, and telephone number of two corporate officers. In all cases, the telephone number must be a number where the individual, partner, or corporate officer can be reached during normal business hours.

**431.3(3)** The application shall include the federal employer identification number of the business. However, if the business is owned by an individual who is not required to have a federal employer identification number, the application shall include the individual's social security number, Iowa nonoperator's identification number or Iowa driver's license number.

**431.3(4)** The application shall include the address of any extension of the applicant's place of business.

**431.3(5)** The application shall indicate the type of business the applicant is engaged in and include the applicant's certification that it complies with the requirements for this type of business.

**431.3(6)** A letter issued by the office responsible for the enforcement of zoning ordinances in the city or county where the applicant's place of business is located must accompany the application. The letter shall state that the business complies with all applicable zoning provisions or is a legal nonconforming use. A compliance letter is also required for any extension of the applicant's place of business.

**431.3(7)** The application shall include a statement of the previous criminal history of the applicant. If the applicant is a corporation, the statement shall be required from each officer. If the applicant is a partnership, the statement shall be required from each partner.

**431.3(8)** The applicant shall include the unique NMVTIS identification number as proof of compliance with registration requirements.

This rule is intended to implement Iowa Code sections 321H.4 and 321H.4A.

[ARC 6489C, IAB 9/7/22, effective 10/12/22]

**761—431.4(321H) Firm name.** A recycler shall not represent or advertise the business under any name or style other than that which appears on the recycler's license.

This rule is intended to implement Iowa Code section 321H.4.

**761—431.5(321H) Denial, suspension or revocation of license.**

**431.5(1)** If an applicant fails to comply with rule 761—431.2(321H) or rule 761—431.3(321H), the department shall deny the application.

**431.5(2)** If a recycler fails to comply with any of the provisions of this chapter of rules, the department may suspend or revoke the recycler's license.

**431.5(3)** The department may deny, revoke or suspend a license for any of the reasons stated in Iowa Code section 321H.6.

**431.5(4)** A person who is aggrieved by a decision of the department and who is entitled to a hearing may contest the decision pursuant to 761—Chapter 13.

This rule is intended to implement Iowa Code chapter 17A and section 321H.6.

**761—431.6(321) Right of inspection.** Peace officers shall have the authority to inspect vehicles or component parts of vehicles and the records and documents required to be kept by a recycler.

This rule is intended to implement Iowa Code section 321.95.

[Filed 9/9/81, Notice 7/22/81—published 9/30/81, effective 11/4/81]

[Filed 5/11/87, Notice 3/11/87—published 6/3/87, effective 7/8/87]

[Filed emergency 6/22/88—published 7/13/88, effective 7/1/88]

[Filed emergency 11/30/89—published 12/27/89, effective 12/1/89]

[Filed 1/15/92, Notice 12/11/91—published 2/5/92, effective 3/11/92]

[Filed 1/14/93, Notice 11/25/92—published 2/3/93, effective 3/10/93]

[Filed 6/19/02, Notice 4/17/02—published 7/10/02, effective 8/14/02]

[Filed 10/11/07, Notice 8/15/07—published 11/7/07, effective 12/12/07]

[Filed ARC 9048B (Notice ARC 8869B, IAB 6/30/10), IAB 9/8/10, effective 10/13/10]

[Filed ARC 0136C (Notice ARC 0068C, IAB 4/4/12), IAB 5/30/12, effective 7/4/12]

[Filed ARC 6489C (Notice ARC 6361C, IAB 6/15/22), IAB 9/7/22, effective 10/12/22]

CHAPTERS 432 to 449  
Reserved



CHAPTER 450  
MOTOR VEHICLE EQUIPMENT

[Appeared as Ch 1, Department of Public Safety, 1973 IDR; amended January 1975 IDR Supplement]  
[Prior to 6/3/87, Transportation Department[820]—(07.E)Ch 1]

**761—450.1(321) Addresses, information and forms.** Assistance under this chapter is available as follows:

**450.1(1)** Information and forms for vehicle registration and certificate of title may be obtained from the county treasurer or by mail from the Motor Vehicle Division, Iowa Department of Transportation, P.O. Box 9278, Des Moines, Iowa 50306-9278; in person at Iowa Department of Transportation, 6310 SE Convenience Blvd., Ankeny, Iowa; by telephone at (515)237-3264; or on the department's website at [www.iowadot.gov](http://www.iowadot.gov).

**450.1(2)** Information for inspections may be obtained from the Bureau of Investigation and Identity Protection, Iowa Department of Transportation, 6310 SE Convenience Boulevard, Ankeny, Iowa; by telephone at (515)237-3050; or on the department's website at [www.iowadot.gov](http://www.iowadot.gov).

This rule is intended to implement Iowa Code section 17A.3.

[ARC 5203C, IAB 10/7/20, effective 11/11/20; ARC 6219C, IAB 3/9/22, effective 4/13/22]

**761—450.2(321) Equipment requirements for specially constructed, reconstructed, street rod, and replica motor vehicles, other than autocycles, motorcycles and motorized bicycles.** The following standards are minimum requirements for constructing and equipping specially constructed, reconstructed, street rod, and replica motor vehicles other than autocycles, motorcycles and motorized bicycles.

**450.2(1) Definitions.** The definitions in Iowa Code section 321.1 and rule 761—400.16(321) are hereby made part of this chapter.

**450.2(2) Application.** As outlined in rule 761—400.16(321), the applicant shall submit the required application forms and exhibits to the county treasurer. The vehicle and ownership documents shall be examined by the department. If the department determines that the motor vehicle complies with this rule, that the integral parts and components have been identified as to ownership, and that the application forms have been completed properly, the department shall assign an identification number to the vehicle and certify that the motor vehicle is eligible for titling and registration. If the frame or unibody specified on an application for a specially constructed, reconstructed, street rod, or replica motor vehicle is designated "not for highway use," the application shall not be approved. The exchange of compatible body parts does not constitute a specially constructed, reconstructed, street rod, or replica motor vehicle. The removal, addition, or substitution of reconstructed motor vehicle parts that modifies the vehicle's external appearance so that it does not reflect the original make or manufacturer model for that model does constitute a specially constructed, reconstructed, street rod, or replica motor vehicle.

**450.2(3) Defroster and defogging device.** Every closed motor vehicle shall be equipped with a device capable of defogging or defrosting the windshield area.

**450.2(4) Door latches.** Every motor vehicle that is equipped with doors leading directly into a compartment that contains one or more seating accommodations shall be equipped with mechanically actuated door latches which firmly and automatically secure the door when pushed closed and which allow each door to be opened from the inside by the actuation of a convenient lever, handle or other nonelectric device. Interior handles must be visible.

**450.2(5) Floor pan.** Every motor vehicle shall be equipped with a floor pan under the entire passenger-carrying compartment. The floor pan shall support the weight of the number of occupants that the vehicle is designed to carry. The floor pan shall be so constructed that it prevents the entry of exhaust fumes.

**450.2(6) Glazing.**

*a. Windshields.* Every motor vehicle shall be equipped with a laminated safety glass windshield that complies with and bears the approval marking of the American National Standards Institute (ANSI) Z 26.1 Standard. The windshield shall be in such a position that it affords continuous horizontal frontal protection to the driver and front seat occupants. The minimum vertical height of the unobstructed windshield glass shall be 6 inches. This paragraph does not preclude the use of a windshield that can be folded down to a horizontal position, provided that the windshield can be firmly fastened in both the vertical and horizontal positions.

*b. Side and rear glass.* Side and rear glass is not required in motor vehicles. If present, however, this glass must be either laminated or tempered safety glass bearing the approval of the ANSI Z 26.1 Standard.

**450.2(7) Driver visibility.** Each motor vehicle shall provide the driver with a minimum outward horizontal vision capability of 90 degrees each side of a vertical plane passing through the fore and aft centerline of the vehicle. This plane of vision may be interrupted by window framing and windshield door support posts not exceeding 4 inches in width at each side location.

**450.2(8) Hood latches.** If a motor vehicle is equipped with a front-opening hood, that hood shall be equipped with a primary and secondary latching system to hold the hood in a closed position.

**450.2(9) Instruments and controls.** Each motor vehicle shall be equipped with:

- a. An operating speedometer calibrated to indicate "miles per hour."
- b. An operating odometer calibrated to indicate "total miles driven."
- c. A steering wheel circular or nearly circular in shape, having an outside diameter of not less than 13 inches.
- d. An accelerator control system that returns the engine throttle to an idle position automatically when the driver removes the actuating force from the accelerator control.

**450.2(10) Brakes.**

- a. Every motor vehicle shall be equipped with brakes acting upon all wheels. The service brakes must be capable of meeting or exceeding the stopping requirements of Iowa Code section 321.431. If necessary, the braking system may be tested by a road test on a public roadway by an officer of the motor vehicle division of the department.
- b. Every motor vehicle shall be equipped with a parking brake operating on at least two wheels applied with required effectiveness despite exhaustion of any source of energy or leakage of any kind in the service brake system. The parking brake shall meet the requirements of Iowa Code sections 321.430 and 321.431.

**450.2(11) Rearview mirror.** Every motor vehicle shall be equipped with two rearview mirrors, each having substantial unit magnification. One shall be mounted on the inside of the vehicle in such a position that it affords the driver a clear view to the rear. The other shall be mounted on the outside of the vehicle on the driver's side in such a position that it affords the driver a clear view to the rear. When an inside mirror does not give a clear view to the rear, a right-hand outside mirror shall be required in lieu thereof. The mirror mounting shall provide a stable support for the mirror, and shall provide for mirror adjustment by tilting in both horizontal and vertical directions. Each mirror shall have a minimum of 10 square inches of reflective surface.

**450.2(12) Seat belts.** Every motor vehicle shall be equipped with at least a Type I (lap belt) seat belt for the driver and each passenger seating position. The belts at each location shall comply with DOT Motor Vehicle Safety Standard No. 209, and shall be firmly anchored to the vehicle body.

**450.2(13) Seating.** All bench-type and individual seats in motor vehicles shall be firmly anchored to structural components or body parts.

**450.2(14) and 450.2(15)** Rescinded IAB 9/8/10, effective 10/13/10.

**450.2(16) Exhaust system.** Every motor vehicle shall have an exhaust system meeting the following requirements:

- a. The system shall be free of leaks, including the exhaust manifold (or headers), piping forward of the muffler, the muffler(s), and tail piping.
- b. Exhaust fumes shall be emitted to the extremity of the vehicle, behind the rear wheels, or to the extremity of the vehicle within 6 inches in front of the rear wheels. Exhaust fumes from trucks, other than enclosed vans, may be emitted to the rear of that part of the vehicle designed for and normally used for carrying the driver and passengers.
- c. Each exhaust system must be equipped with a muffler that prevents excessive noise.
- d. No part of the exhaust system shall pass through any area of the vehicle that is used as a passenger-carrying compartment, and shall be so constructed that persons entering the vehicle cannot make contact with the exhaust system.
- e. All exterior side exhaust pipes must be fully shielded and any vertical truck exhaust stacks shall be shielded to the top of the cab.

**450.2(17) Frame.** Every vehicle shall be equipped with a frame consisting of wall box tubing, round tubing, wall channel or unitized construction capable of supporting the vehicle, its load and the torque produced by the power source.

**450.2(18) Fuel system.** Every motor vehicle shall have a fuel system in which all components are securely fastened with fasteners designed for this purpose, including the tank, tubing, hoses, clamps, etc. The filler from the system shall be located in a position not within the passenger-carrying compartment, and shall be capped. The system shall be leakproof, and fuel lines shall be positioned so as not to come in contact with high temperature surfaces or moving parts.

**450.2(19) Steering and suspension.**

- a. Every motor vehicle shall have no parts extending below the wheel rims in their lowest position, except for tires and electrical grounding devices designed for this purpose.
- b. The steering system shall remain unobstructed when turned from lock to lock.
- c. The steering wheel shall have no less than two turns and no more than six turns when turning the road wheels from lock to lock.
- d. While in a sharp turn at a speed between 5 and 15 MPH, release of the steering wheel shall result in a distinct tendency for the vehicle to increase its turning radius.

e. No motor vehicle shall be constructed so that the weight on any axle is less than 20 percent of the gross weight of the vehicle and load.

f. Motor vehicles shall be equipped with a damping device at each wheel location providing a minimum relative motion between the unsprung axle and the chassis of plus or minus 2 inches.

g. When each corner of the vehicle is depressed and released the damping device shall stop vertical body motion within two cycles.

h. There shall be no heating or welding on coil springs, leaf springs, or torsion bars.

**450.2(20) Tires.** Tires shall comply with Iowa Code section 321.440. Each tire shall have a load-bearing capacity in keeping with the size and weight of the vehicle.

**450.2(21) Lighting and electrical system.** Each motor vehicle shall be equipped with approved lighting devices in sufficient number, type, and locations to meet the requirements of Iowa Code sections 321.384 to 321.423, including headlamps, rear lamps, license plate lamp, rear reflectors, parking lamps, stop lamps, turn signals, and high-low beam indicator. In addition, every motor vehicle shall be equipped with:

a. A driver-controlled switch capable of selecting high and low beams (dimmer switch).

b. A motor vehicle more than 40 inches in width shall be equipped with turn signal lamps and have a manually operated switch controlled by the driver that shall cause the turn signal lamps to function. This switch shall be self-canceling.

c. A horn that shall be electrically actuated, and shall emit a sound clearly audible from a distance of 200 feet. The horn shall be actuated with a switch easily accessible to the driver when operating the vehicle.

d. All wiring shall be done in an orderly and workmanlike fashion, with no wiring in contact with high temperature surfaces or moving parts.

e. Headlamps shall be in a plane that is perpendicular to a vertical plane through the longitudinal centerline of the vehicle. The headlamps shall be mounted not less than 24 inches, nor more than 54 inches, above the road surface when measured to the headlamp center.

f. A tail lamp or lamps shall be mounted on the rear of the motor vehicle or vehicle, exhibiting a red light plainly visible from a distance of 500 feet to the rear. The tail lamp or lamps shall be mounted not less than 15 inches, nor more than 72 inches, above the roadway.

g. All original lamps and lighting equipment provided on the motor vehicle by the manufacturer shall be maintained in working condition or shall be replaced with equivalent equipment.

This rule is intended to implement Iowa Code section 321.23.

[ARC 9048B, IAB 9/8/10, effective 10/13/10; ARC 5203C, IAB 10/7/20, effective 11/11/20]

**761—450.3(321) Mud and snow tire.** A mud and snow tire is a tire that is designed to provide additional starting, stopping and driving traction in mud and snow. The tread design shall have ribs, lugs, blocks or knobs which are discontinuous and have a minimum separation of one-eighth of an inch between the ribs, lugs, blocks or knobs. A substantial portion of the rib, lug, block or knob edge in the design of the tread shall be at an angle greater than 30 degrees to the periphery centerline. A mud and snow tire must comply with the tire restrictions expressed in Iowa Code section 321.440.

A tire labeled “Mud and Snow” or any contraction using the letters “M” and “S,” such as “MS,” “M/S,” “M-S” or “M & S” shall be considered a mud and snow tire.

A representation of the distinguishing features of a mud and snow tire is pictured below.

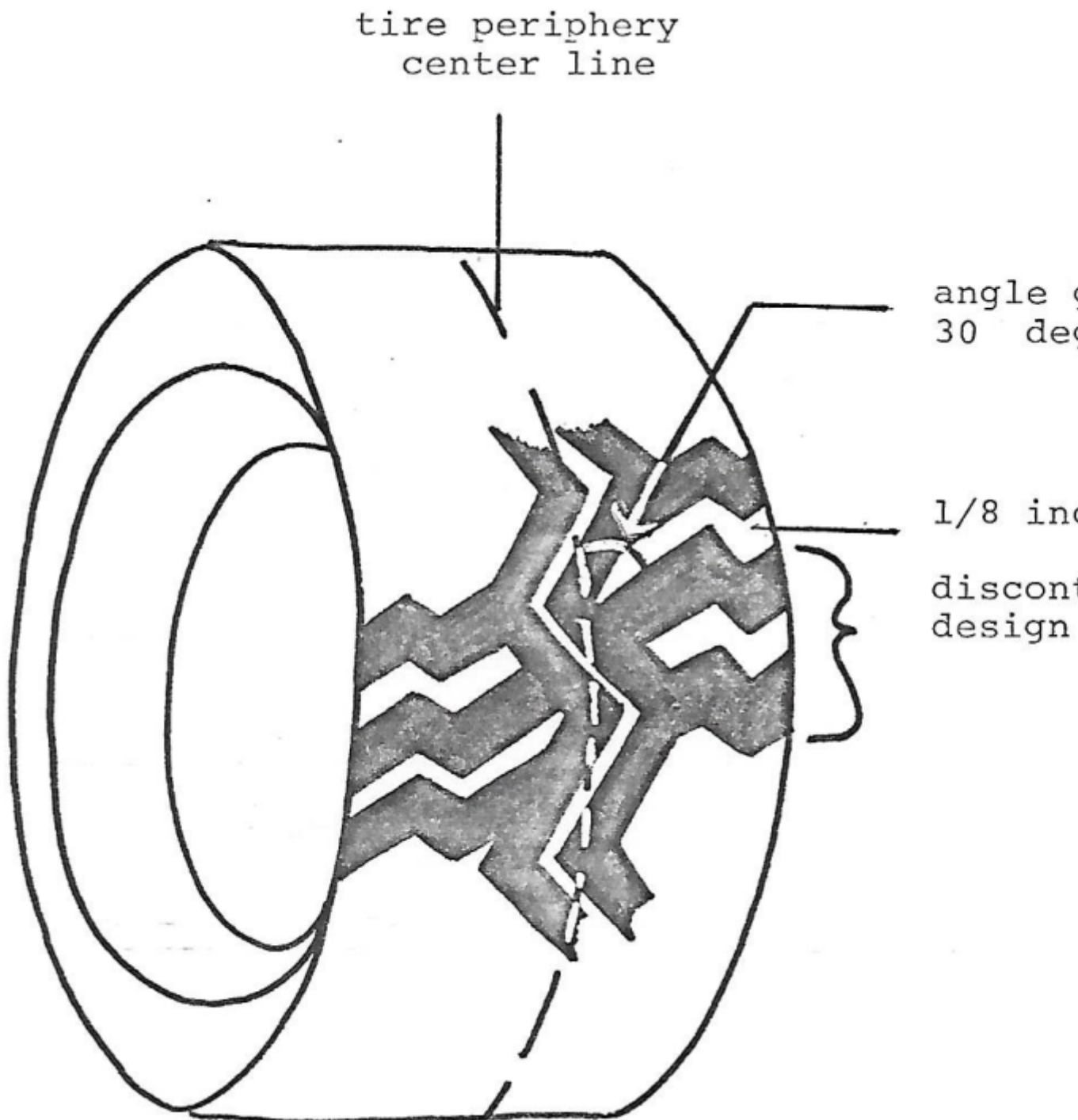

This rule is intended to implement Iowa Code subsection 321.236(12).

**761—450.4(321) Minimum requirements for constructing and equipping specially constructed or reconstructed motorcycles or motorized bicycles.** Minimum requirements for constructing and equipping specially constructed or reconstructed motorcycles or motorized bicycles as defined in Iowa Code section 321.1 are as follows:

**450.4(1) Application.** As outlined in rule 761—400.16(321), the applicant shall submit the required application forms and exhibits to the county treasurer. The vehicle and ownership documents shall be examined by the department. If the department determines that the motor vehicle complies with this rule, that the integral parts and components have been identified as to ownership, and that the application forms have been completed properly, the department shall assign an identification number to the vehicle and certify that the motor vehicle is eligible for titling and registration. If the frame specified on an application for a specially constructed or reconstructed motorcycle or

motorized bicycle is designated “not for highway use,” the application shall not be approved. The exchange of compatible body parts does not constitute a specially constructed or reconstructed motorcycle or motorized bicycle. The removal, addition, or substitution of a reconstructed motorcycle or motorized bicycle part that modifies the vehicle’s external appearance so that it does not reflect the original make or manufacturer model does constitute a specially constructed, reconstructed, street rod, or replica motorcycle or motorized bicycle. EXEMPTION: The conversion of a manufactured motorcycle from two wheels to three-wheel operation by the addition or substitution of a bolt-on conversion kit shall not constitute a reconstructed motorcycle.

**450.4(2) Upgrade pulls—minimum speed.** No motor vehicle or combination of vehicles which cannot proceed up a 3 percent grade, on dry concrete pavement, at a minimum speed of 20 miles per hour, shall be operated upon the highways of this state.

**450.4(3) Engine.** Rescinded IAB 9/8/10, effective 10/13/10.

**450.4(4) Frame/chassis.** A motorcycle or motorized bicycle frame/chassis, including the suspension components and engine mountings, shall be of sufficient strength, capable of supporting the combined weight of all vehicle components and riders for which the vehicle was designed.

**450.4(5) Front end assembly.**

*a. Trail (extended fork measured in inches).* No reconstructed or specially constructed motorcycle or motorized bicycle shall have the front fork so extended as to place the center of the front wheel axle farther than 36 inches from a vertical plane through the steering axis.

*b. Rake (extended fork measured in degrees).* No reconstructed or specially constructed motorcycle or motorized bicycle shall have the front fork so extended as to exceed a 45-degree angle between the fork assembly and a vertical plane through the steering axis.

*c. Extensions.* No reconstructed or specially constructed motorcycle or motorized bicycle shall be equipped with extension slugs. However, one-piece extension tubes and springer units, if approved, are acceptable.

*d. Wheelbase.* No reconstructed or specially constructed motorcycle or motorized bicycle shall have an overall wheelbase, measured from the center of the front axle to the center of the rear axle, of less than 40 inches.

*e. Motorcycle front end geometry.* A representation of the front end geometry of a motorcycle is depicted in the Appendix to this rule.

**450.4(6) Brakes.** Every motorcycle and motorized bicycle shall be equipped with at least a rear brake. If the vehicle is also equipped with a front brake, all control cables, lines and hoses shall be located and secured so as not to become pinched between the fork and frame members when the wheel is turned completely to the left or right. Brake-actuating devices shall be in a readily accessible location, unencumbered by vehicle components. A suitable mechanism shall be provided for the purpose of automatically returning the actuating devices to a normal position upon release.

**450.4(7) Tires, wheels, rims.** Motorcycle tires shall be of pneumatic design with a minimum width of two and twenty-five hundredths inches and designed for highway use. Wheel rim diameters shall not be less than 10 inches and rims shall otherwise comply with applicable federal standards.

**450.4(8) Steering and suspension.**

*a. Stability.* Motorcycle or motorized bicycle steering and suspension shall provide the operator with the means of safely controlling vehicle direction.

*b. Wheel alignment.* The rear wheel of a two-wheel motorcycle or motorized bicycle shall track behind the front wheel within 1 inch with both wheels in a vertical plane when the vehicle is operating on a straight course. On a three-wheel motorcycle or motorized bicycle, the two wheels mounted on the rear axle shall have a wheel track distance not less than 30 inches and the midpoint of the rear wheel track distance shall be within 1 inch of the front wheel track when the vehicle is proceeding on a straight course.

*c. Steering.*

(1) The steering head shall be provided with a bearing or similar device that will allow the steering shaft to turn freely in rotational motion only. All handlebar-mounted control cables, wires, lines and hoses shall be located and secured so as not to become pinched between the fork and frame members when the wheel is turned completely to the right or the left.

(2) A steering wheel may be used on a three-wheel reconstructed or specially constructed motorcycle or motorized bicycle provided:

1. The steering wheel is circular or nearly circular in shape, having an outside diameter of not less than 13 inches.

2. The steering wheel shall have no less than two turns and no more than six turns when the road wheels are turned from lock to lock.

*d. Handlebars.* Handlebars shall be of sturdy construction, adequate in size (length) to provide proper leverage for steering, and capable of withstanding a minimum force of 100 pounds applied to each hand grip in any direction. The handlebars shall provide a minimum distance of 18 inches between grips after final assembly.

*e. Hand grips.* Motorcycles or motorized bicycles shall have handlebars equipped with hand grips of nonslip design or material.

*f. Suspension.* Motorcycles or motorized bicycles shall be equipped with a suspension system, and the suspension system shall be applicable to at least the front wheel. The suspension system(s) shall be designed for the purpose of maximum vehicle stability.

**450.4(9) Fuel system.** All fuel system components, including the tank, pump, tubing, hoses, clamps, etc., shall be securely fastened to the motorcycle or motorized bicycle so as not to interfere with vehicle operation and be leakproof when the vehicle is in its normal operating attitude. Fuel lines and tank shall be positioned in a manner so as to prevent their contact with the engine head, manifold, exhaust system, or other high temperature surfaces or moving components. The fuel system shall be adequately vented and provided with a fuel shutoff valve located between the fuel supply and the engine.

**450.4(10) Exhaust system.** Motorcycles or motorized bicycles with an internal combustion engine shall be equipped with an exhaust system incorporating a muffler or other mechanical device for the purpose of reducing engine noise. Cutouts and bypasses in the exhaust system are prohibited. The system shall be leakproof and all components shall be securely attached to the vehicle and located so as not to interfere with the operation of the motorcycle or motorized bicycle. Shielding shall be provided to prevent inadvertent contact with the exhaust system by the operator and/or passenger during normal operations.

**450.4(11) Mirrors.** Every motorcycle and motorized bicycle shall be equipped with at least one mirror of unit magnification, securely affixed to the handlebar and capable of adjustment within a range that will reflect an image that includes at least the horizon and the road surface to the rear of the motorcycle or motorized bicycle. The mirror shall consist of a minimum reflective surface of 10 square inches. All mirrors shall be regular in shape (circular, oval, rectangular, or square) and shall not contain sharp edges or projections capable of producing injury.

**450.4(12) Fenders.** Rescinded IAB 9/8/10, effective 10/13/10.

**450.4(13) Seat or saddle.** A seat or saddle securely attached to the vehicle shall be provided for the use of the operator. The seat or saddle shall not be less than 20 inches above a level road surface when measured to the lowest point on top of the seat or saddle cushion with the driver seated in a driving position. The seat or saddle adjustment locking device shall prevent relative movement of the seat from its selected and secured position under all normal vehicle operating conditions.

**450.4(14) Horn.** Every motorcycle and motorized bicycle shall be equipped with at least one horn. The horn shall be electrically operated and shall operate from a control device located on the handlebar. When operated the horn shall be audible for at least 200 feet.

**450.4(15) Speedometer and odometer.** Every motorcycle and motorized bicycle shall be equipped with a properly operating speedometer and odometer calibrated in miles per hour and miles respectively and shall be fully illuminated when the headlamp(s) is activated.

**450.4(16) Lighting equipment.** Every motorcycle and motorized bicycle shall be equipped with at least one headlamp but not more than two, mounted securely. Headlamp(s) shall be mounted not less than 24 inches, nor more than 54 inches, above the level road surface. A headlight beam indicator light shall be located within the operator's field of vision and illuminated automatically when the high beam of the headlamp is actuated. Every motorcycle and motorized bicycle shall be equipped with a tail and brake light assembly and a license plate light. All original lamps and lighting equipment provided on the motor vehicle by the manufacturer shall be maintained in working condition or shall be replaced with equivalent equipment.

**450.4(17) Footrest.** Every motorcycle shall be equipped with two footrests, one on each side of the vehicle and shall be provided for each designated seating position. Footrests shall be located so as to provide reasonable accessibility. Footrests shall be able to fold upward if they protrude beyond the side of the motorcycle's fixed items. Every motorized bicycle shall be equipped with either two footrests or two pedals, one on each side of the vehicle, to provide reasonable accessibility.

**450.4(18) Highway bars.** If a motorcycle or motorized bicycle is so equipped, highway bars (alternate footrests) shall be located at a maximum distance of 26 inches from the foot controls and shall not interfere with the operation of the foot controls.

This rule is intended to implement Iowa Code section 321.23.

[ARC 9048B, IAB 9/8/10, effective 10/13/10; ARC 3108C, IAB 6/7/17, effective 7/12/17; ARC 5203C, IAB 10/7/20, effective 11/11/20]

**761—450.5(321) Minimum requirements for constructing and equipping specially constructed or reconstructed autocycles.** Minimum requirements for constructing and equipping specially constructed or reconstructed autocycles as defined in Iowa Code section 321.1 are as follows:

**450.5(1) Application.** As outlined in rule 761—400.16(321), the applicant shall submit the required application forms and exhibits to the county treasurer. The vehicle and ownership documents shall be examined by the department. If the department determines that the autocycle complies with rule 761—450.5(321), that the integral parts and components have been identified as to ownership, and that the application forms have been completed properly, the department shall assign an identification number to the autocycle and certify that the autocycle is eligible for titling and registration. If the frame or unibody specified on an application for a specially constructed, reconstructed, street rod, or replica autocycle is designated “not for highway use,” the application shall not be approved. The exchange of compatible body parts does not constitute a specially constructed, reconstructed, street rod, or replica autocycle. The removal, addition, or substitution of reconstructed autocycle parts that modifies the autocycle’s external appearance so that it does not reflect the original make or manufacturer model for that model does constitute a specially constructed, reconstructed, street rod, or replica autocycle.

**450.5(2) Seat belt.** A seat belt for each seat shall be installed in the autocycle in accordance with Federal Motor Vehicle Safety Standard No. 209.

**450.5(3) Seat.** A seat that is firmly attached to the autocycle and does not require the operator to straddle or sit astride shall be provided for the use of the operator.

**450.5(4) Lighting equipment.** Every autocycle shall be equipped with at least one headlamp, at least one taillight, and either a taillight or a separate white light that illuminates the license plate if a taillight does not. All original lamps and lighting equipment provided on the autocycle by the manufacturer shall be maintained in working condition or shall be replaced with equivalent equipment.

**450.5(5) Warning devices.** Every autocycle shall be equipped with at least one red reflector, either separate or as part of the taillight or taillights.

**450.5(6) Brakes.** Every autocycle shall be equipped with a braking system, other than a parking brake, in accordance with Iowa Code section 321.431.

**450.5(7) Horn.** Every autocycle shall be equipped with a horn that shall be electrically actuated and shall emit a sound clearly audible from a distance of 200 feet.

**450.5(8) Exhaust system.** Each autocycle with an internal combustion engine shall be equipped with a muffler and emission control system in accordance with federal regulation 49 CFR 393.83. When a muffler and emission control system is factory equipped, neither may be removed.

**450.5(9) Mirrors.** Every autocycle shall be equipped with a mirror that shall consist of a minimum reflective surface of 10 square inches. All mirrors shall be regular in shape (circular, oval, rectangular, or square) and shall not contain sharp edges or projections capable of producing injury.

**450.5(10) Tires.** Every autocycle shall be equipped with tires that comply with the requirements of Iowa Code section 321.440.

**450.5(11) Floor pan.** Every autocycle shall be equipped with a floor pan under the entire passenger-carrying compartment. The floor pan shall support the weight of the number of occupants that the autocycle is designed to carry. The floor pan shall be so constructed that it prevents the entry of exhaust fumes.

This rule is intended to implement Iowa Code section 321.23.

[ARC 5203C, IAB 10/7/20, effective 11/11/20]

**761—450.6(321) Safety requirements for the movement of implements of husbandry on a roadway.** Transferred to 661—24.1(321), IAC Supplement 8/7/24.

**761—450.7(321) Front windshields, windows or sidewings.**

**450.7(1) Prohibition.** Except as provided in Iowa Code section 321.438(2), a person shall not operate on the highway a motor vehicle equipped with a front windshield, a side window to the immediate right or left of the driver (front side window) or a sidewing forward of and to the left or right of the driver (front sidewing) which is excessively dark or reflective.

**450.7(2) Standard of transparency.** “Excessively dark or reflective” means that the windshield, front side window or front sidewing does not meet a minimum standard of transparency of 70 percent light transmittance.

**450.7(3) Dark window exemption.**

*a.* Effective July 4, 2012, no exemption shall be granted from the minimum standard of transparency set forth in subrule 450.7(2).

*b.* A motor vehicle fitted with a front windshield, a front side window or a front sidewing with less than 70 percent but not less than 35 percent light transmittance before July 4, 2012, may continue to be maintained and operated with a front windshield, a front side window or a front sidewing with less than 70 percent but not less than 35 percent light transmittance on or after July 4, 2012, so long as the vehicle continues to be used for the transport of a passenger or operator who obtained Form 432020, which documented a medical need for such reduced transparency, and was signed by the person's physician before July 4, 2012. Form 432020 must be carried at all times in the vehicle to which the exemption applies. At such time as the vehicle is no longer used for the transport of the passenger or operator who is the subject of Form 432020, the exemption expires and may not be renewed. The owner of the vehicle to which the exemption applied must return the vehicle to conformance with the minimum standard of transparency set forth in subrule 450.7(2) within 60 days of expiration of the exemption.

*c.* "Physician" as used in this rule means a person licensed under Iowa Code chapter 148, 151 or 154.

This rule is intended to implement Iowa Code section 321.438.

[ARC 0136C, IAB 5/30/12, effective 7/4/12]

[ARC 6219C, IAB 3/9/22, effective 4/13/22]

APPENDIX TO RULE  
761—450.2(321)  
Rescinded IAB 9/8/10, effective 10/13/10

APPENDIX TO RULE  
761—450.4(321)

# MOTORCYCLE FRONT END GEOM

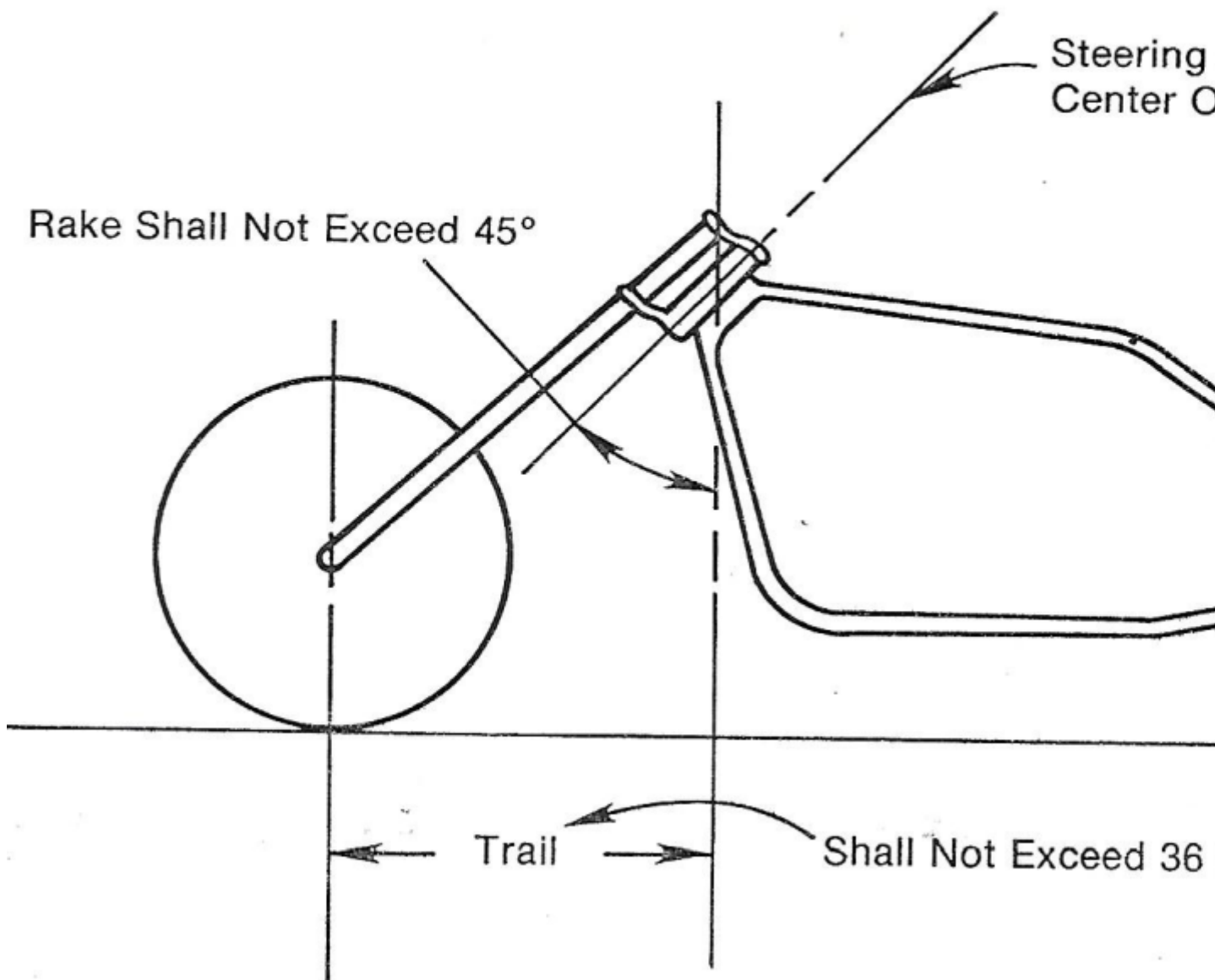

[Filed 6/30/61; amended 6/14/72, 12/9/74;  
Transferred to Department of Transportation 7/1/75]  
[Emergency amendment filed 10/10/75—published 10/20/75, effective 11/1/75]

[Filed 3/17/76, Notice 1/26/76—published 4/5/76, effective 5/10/76]  
[Filed 10/26/79, Notice 9/5/79—published 11/14/79, effective 12/19/79]  
[Filed 1/28/82, Notice 12/9/81—published 2/17/82, effective 3/24/82]  
[Filed 9/8/83, Notice 7/20/83—published 9/28/83, effective 11/2/83]  
[Filed 12/23/83, Notice 11/9/83—published 1/18/84, effective 2/22/84]  
[Filed 1/9/85, Notice 11/21/84—published 1/30/85, effective 3/6/85]  
[Filed 2/7/86, Notice 12/18/85—published 2/26/86, effective 4/2/86]  
[Filed emergency 6/20/86—published 7/16/86, effective 7/1/86]  
[Filed 8/29/86, Notice 7/16/86—published 9/24/86, effective 10/29/86]  
[Filed 5/11/87, Notice 3/11/87—published 6/3/87, effective 7/8/87]  
[Filed emergency 3/30/88—published 4/20/88, effective 4/1/88]  
[Filed 6/22/88, Notice 4/20/88—published 7/13/88, effective 8/17/88]  
[Filed 11/3/88, Notice 9/21/88—published 11/30/88, effective 1/4/89]  
[Filed emergency 11/30/89—published 12/27/89, effective 12/1/89]  
[Filed emergency 8/8/90—published 9/5/90, effective 8/10/90]  
[Filed 11/7/90, Notice 9/5/90—published 11/28/90, effective 1/2/91]  
[Filed 12/18/92, Notice 10/28/92—published 1/6/93, effective 2/10/93]  
[Filed 12/16/93, Notice 11/10/93—published 1/5/94, effective 2/9/94]  
[Filed 11/29/95, Notice 10/25/95—published 12/20/95, effective 1/24/96]  
[Filed 3/5/97, Notice 1/29/97—published 3/26/97, effective 4/30/97]  
[Filed 10/28/98, Notice 8/26/98—published 11/18/98, effective 12/23/98]  
[Filed 6/19/02, Notice 4/17/02—published 7/10/02, effective 8/14/02]  
[Filed ARC 9048B (Notice ARC 8869B, IAB 6/30/10), IAB 9/8/10, effective 10/13/10]  
[Filed ARC 0136C (Notice ARC 0068C, IAB 4/4/12), IAB 5/30/12, effective 7/4/12]  
[Filed ARC 3108C (Notice ARC 2989C, IAB 3/29/17), IAB 6/7/17, effective 7/12/17]  
[Filed ARC 5203C (Notice ARC 5101C, IAB 7/29/20), IAB 10/7/20, effective 11/11/20]  
[Filed ARC 6219C (Notice ARC 6118C, IAB 12/29/21), IAB 3/9/22, effective 4/13/22]  
[Editorial change: IAC Supplement 8/7/24]

CHAPTER 451  
EMERGENCY VEHICLE CERTIFICATE  
[Prior to 6/3/87, see Transportation Department[820]—(07,E) Ch 2]

**761—451.1(321) Information.** Information about certificates of designation for authorized emergency vehicles is available by mail from the Motor Vehicle Division, Iowa Department of Transportation, P.O. Box 9278, Des Moines, Iowa 50306-9278; in person at 6310 SE Convenience Blvd., Ankeny, Iowa; by telephone at (515)237-3110; by email at [vsusto@iowadot.us](mailto:vsusto@iowadot.us); or on the department's website at [www.iowadot.gov](http://www.iowadot.gov).

This rule is intended to implement Iowa Code sections 321.2 and 321.3.

[ARC 2755C, IAB 10/12/16, effective 11/16/16; ARC 6308C, IAB 5/4/22, effective 6/8/22]

**761—451.2(321) Authorized emergency vehicle certificate.**

**451.2(1) Application.** Application for a certificate which designates a privately owned vehicle as an authorized emergency vehicle shall be submitted to the motor vehicle division in the form and manner prescribed by the department. The department shall deny an application if the applicant does not establish for the department that the vehicle will be used as an authorized emergency vehicle, as described in Iowa Code section 321.451, that the vehicle does not otherwise demonstrate necessity for the designation, or that the applicant does not meet the criteria for issuance of a certificate established by Iowa Code section 321.451.

**451.2(2) Expiration.** The certificate of designation expires at midnight on the thirty-first day of December five years from the year in which it was issued.

**451.2(3) Limitation.** In addition to the provisions of Iowa Code sections 321.231(2), 321.231(4), 321.231A, 321.324A(3A) and 321.451, a towing or recovery vehicle with a valid certificate of designation may only display illuminated emergency lights in one of the following circumstances:

*a.* When the vehicle is at the scene of an emergency, which includes an incident dangerous to the public or roadside operations where increased visibility will mitigate risk of traffic hazards.

*b.* When otherwise authorized by a law enforcement officer.

This rule is intended to implement Iowa Code sections 321.231, 321.231A, 321.324A(3A) and 321.451.

[ARC 2755C, IAB 10/12/16, effective 11/16/16; ARC 6308C, IAB 5/4/22, effective 6/8/22; ARC 6845C, IAB 2/8/23, effective 3/15/23]

**761—451.3(17A,321) Application denial or certificate revocation.**

**451.3(1)** The department may deny an application or revoke a certificate of designation if an applicant or certificate holder fails to comply with the applicable provisions of this chapter or Iowa Code section 321.231, 321.231A, 321.324A(3A) or 321.451; or if the certificate holder is no longer eligible for the certificate, or the certificate holder otherwise abuses the certification.

**451.3(2)** The department shall send notice by certified mail to a person whose certificate of designation is to be revoked. The department shall send notice by first-class mail when an application is denied. The notice shall be mailed to the person's mailing address as shown on departmental records, and the revocation or denial shall become effective 20 days from the date mailed. A person who is aggrieved by a decision of the department and who is entitled to a hearing may contest the decision in accordance with 761—Chapter 13. The request shall be submitted in writing to the director of the motor vehicle division. The request shall be deemed timely submitted if it is delivered or postmarked on or before the effective date specified in the notice of revocation or denial.

This rule is intended to implement Iowa Code chapter 17A and sections 321.13, 321.16, 321.231, 321.231A, 321.324A(3A) and 321.451.

[ARC 2755C, IAB 10/12/16, effective 11/16/16; ARC 6308C, IAB 5/4/22, effective 6/8/22; ARC 6845C, IAB 2/8/23, effective 3/15/23]

[761—Chapter 451 appeared as Ch 2, Department of Public Safety, 1973 IDR]

[Filed 11/13/62; transferred to Department of Transportation 7/1/75]

[Filed 2/7/86, Notice 12/18/85—published 2/26/86, effective 4/2/86]

[Filed 5/11/87, Notice 3/11/87—published 6/3/87, effective 7/8/87]

[Filed 11/3/88, Notice 9/21/88—published 11/30/88, effective 1/4/89]

[Filed emergency 11/30/89—published 12/27/89, effective 12/1/89]

[Filed 11/29/95, Notice 10/25/95—published 12/20/95, effective 1/24/96]

[Filed 6/19/02, Notice 4/17/02—published 7/10/02, effective 8/14/02]

[Filed 11/2/05, Notice 9/14/05—published 11/23/05, effective 12/28/05]

[Filed 10/11/07, Notice 8/15/07—published 11/7/07, effective 12/12/07]

[Filed ARC 2755C (Notice ARC 2640C, IAB 8/3/16), IAB 10/12/16, effective 11/16/16]

[Filed ARC 6308C (Notice ARC 6141C, IAB 1/12/22), IAB 5/4/22, effective 6/8/22]

[Filed ARC 6845C (Notice ARC 6702C, IAB 11/30/22), IAB 2/8/23, effective 3/15/23]

CHAPTER 452  
REFLECTIVE DEVICES ON SLOW-MOVING VEHICLES  
[Appeared as Ch 3, Department of Public Safety, 1973 IDR]  
[Prior to 6/3/87, Transportation Department[820]—(07,E) Ch 3]  
Transferred to 661—Chapter 23, IAC Supplement 8/7/24

CHAPTER 453  
WEIGHT EQUALIZING HITCH AND SWAY CONTROL  
DEVICES FOR TRAILERS  
Rescinded IAB 1/23/02, effective 2/27/02



CHAPTER 454  
TOWING WRECKED OR DISABLED VEHICLES

**761—454.1(321) Definitions.** For the purpose of Iowa Code section 321.463, the following definitions are established:

“*Tow*” means the transportation by a vehicle designed to tow or transport wrecked or disabled vehicles directly from the scene of a crash, disablement, or impoundment to any place of repair, storage, or safekeeping.

“*Wrecked or disabled vehicle*” means a vehicle upon a highway involved in a crash or having mechanical failure, broken parts, or other defects, any of which prevent the vehicle from moving safely under its own power, or any vehicle impounded by the order of a peace officer.

This rule is intended to implement Iowa Code section 321.463.

[Filed 2/10/99, Notice 12/30/98—published 3/10/99, effective 4/14/99]

[Filed 12/19/01, Notice 11/14/01—published 1/23/02, effective 2/27/02]



CHAPTERS 455 to 479  
Reserved



CHAPTER 480  
ABANDONED VEHICLES

[Prior to 6/3/87, Transportation Department[820]—(07,D) Ch 2]

**761—480.1(321) Definitions.** The definitions in Iowa Code section 321.1 and subsection 321.89(1) apply to this chapter. In addition:

“*Abandoned vehicle*,” when used in Iowa Code section 321.89 and this chapter of rules, means only those vehicles subject to registration as referred to in Iowa Code section 321.18.

“*Bidder registry*” means a record of all persons who have registered to bid at a public auction.

“*Public auction*,” when used in Iowa Code section 321.89, means an auction open to the general public. A public auction may be by electronic means, by sealed bid, or a conventional oral auction. The highest bidder is awarded the property. When the auction is a conventional oral auction, bidders shall register and bring the bid deposit with them to the auction on the day and at the location and time specified for the sale, if a bid deposit is required. Bidders bid against one another until bidding stops.

[ARC 9048B, IAB 9/8/10, effective 10/13/10; ARC 5257C, IAB 11/4/20, effective 12/9/20]

**761—480.2(321) Location.** Information, forms and instructions are available from: Vehicle and Motor Carrier Services Bureau, Iowa Department of Transportation, P.O. Box 9278, Des Moines, Iowa 50306-9278 or the department’s website at [www.iowadot.gov](http://www.iowadot.gov).

[ARC 9048B, IAB 9/8/10, effective 10/13/10; ARC 5257C, IAB 11/4/20, effective 12/9/20]

**761—480.3(321) General requirements.**

**480.3(1)** A police authority shall report an abandoned vehicle to the department only if it is remitting unclaimed profits or requesting reimbursement.

**480.3(2)** A private entity designated by a police authority to process an abandoned vehicle may request reimbursement of expenses that are in excess of the proceeds of the sale of the abandoned vehicle.

**480.3(3)** To request reimbursement, the police authority or private entity shall complete and submit to the department an abandoned vehicle report on a form and in the manner prescribed by the department. Other forms may be accepted if they contain all information deemed necessary by the department.

**480.3(4)** A police authority shall also complete and submit the prescribed abandoned vehicle report form when remitting unclaimed profits pursuant to rule 761—480.7(321).

**480.3(5)** The department shall reimburse the police authority or private entity only for losses incurred in disposing of a vehicle abandoned on a public highway.

**480.3(6)** If a police authority has designated a private entity to process an abandoned vehicle, the police authority shall provide to the private entity a certificate of disposal form prescribed by the department. On the form, the police authority shall provide a description of the vehicle and list the name and address of the last registered owner, all known lienholders of record, and any other known claimants to the vehicle.

**480.3(7)** If a police authority has designated a private entity to process an abandoned vehicle, the police authority is eligible for reimbursement of only the towing expense.

**480.3(8)** A police authority or a private entity designated by a police authority holding a public auction may set the initial bid at an amount that equals the actual cost of storage and towing.

**480.3(9)** A police authority or private entity processing an abandoned vehicle shall maintain records for three years from the sale at a public auction or transfer of a motor vehicle to a demolisher. The records shall be open to inspection by any peace officer or any employee of the department. The required documents to be made available for inspection shall include:

*a.* The motor vehicle record request results letter issued by the department with lien information or evidence that a motor vehicle record was reviewed for owners and liens through other legal means.

*b.* The National Motor Vehicle Title Information System (NMVTIS) report when no Iowa owner or lienholders are identified.

*c.* The impound report with the date of abandonment.

*d.* One copy of the dated notice sent by the police authority or private entity to each owner and lienholder or proof of publication of notice with the publication date visible.

*e.* One copy of actual newspaper page advertising each public auction with advertisement and date visible.

*f.* A copy of the certificate of disposal for the private entity.

*g.* The bidder registry for the police authority or private entity designated by a police authority holding a public auction.

*h.* A copy of affidavit of sale on a form prescribed by the department.

**480.3(10)** A police authority or private entity shall verify that the provisions of this chapter have been executed, prior to the sale of the abandoned vehicle, on a form prescribed by the department.

**480.3(11)** A police authority or private entity shall be limited to two attempts at selling an abandoned vehicle at a public auction. If the police authority or private entity cannot make a satisfactory sale at two public auctions, or if a sale cannot otherwise be made with enough proceeds to cover the expenses and costs in carrying out the abandoned vehicle process, the police authority or private entity shall sell or dispose of the vehicle to a demolisher for junk.

**480.3(12)** A purchaser in good faith of a motor vehicle sold as a result of the abandoned vehicle process takes the motor vehicle free of all rights of all persons, including holders of preexisting liens, notwithstanding any police authority or private entity's noncompliance with this chapter.

**480.3(13)** Upon presentation of a sales receipt, a county official shall process the registration and issuance of title to the purchaser free of all rights of all persons, including holders of preexisting liens, notwithstanding any police authority or private entity's noncompliance with this chapter.

[ARC 5257C, IAB 11/4/20, effective 12/9/20]

#### **761—480.4(321) Advertising.**

**480.4(1)** A public auction shall be advertised at least seven days in advance within the county where the auction will take place or where the vehicle is physically located. At minimum, the manner of the advertising shall be:

*a.* Published in a newspaper which meets the requirements set forth in Iowa Code section 618.3; and

*b.* Posted in a conspicuous manner viewable to the public at the location where the public auction will occur. If the public auction is to be conducted by electronic means, the location shall be the specific website to be used for the auction.

**480.4(2)** If a vehicle is not sold at the scheduled public auction, any subsequent attempt to sell the vehicle by auction must be preceded by advertising pursuant to this rule.

[ARC 5257C, IAB 11/4/20, effective 12/9/20]

#### **761—480.5(321) Bidder registry.**

**480.5(1)** A police authority or private entity designated by a police authority shall maintain for three years the bidder registry for each auctioned vehicle sold or offered for sale at a public auction. The bidder registry shall be open for inspection by any peace officer or department employee. For each auctioned vehicle, the bidder registry shall contain:

*a.* The full name of the bidder.

*b.* The bona fide address of the bidder.

*c.* A telephone number of the bidder.

*d.* The date of the auction.

*e.* The auctioned vehicle's make, model, model year, and vehicle identification number.

*f.* The location of the auction.

**480.5(2)** Reserved.

[ARC 5257C, IAB 11/4/20, effective 12/9/20]

#### **761—480.6(321) Odometer statement.**

**480.6(1)** When a vehicle is sold at a public auction and the seller cannot attest to the true mileage reading of the vehicle's odometer, the seller shall complete the odometer disclosure statement, when required pursuant to Iowa Code section 321.71, in the following manner:

*a.* The odometer statement shall reflect the odometer mileage reading at the time of sale; and

*b.* The odometer statement shall be marked indicating "odometer discrepancy," certifying the odometer mileage reading is not the actual mileage.

**480.6(2)** The subsequent title issued for the vehicle shall record the vehicle's mileage is "not actual."

[ARC 5257C, IAB 11/4/20, effective 12/9/20]

#### **761—480.7(321) Abandoned vehicle report.**

**480.7(1)** *Impound report.* The police authority or private entity shall submit with the abandoned vehicle report the police authority's impound report showing the date the vehicle was taken into custody and providing a complete description of the vehicle. The date the vehicle was taken into custody is the date of abandonment unless the police authority declares a different date of abandonment. The abandonment date shall be used to calculate the 20-day notification period to the owner and lienholder(s).

**480.7(2) Notice.** The police authority or private entity shall submit with the abandoned vehicle report a copy of the notice sent to the owner and lienholder(s) or proof of publication of notice. The department shall not reimburse any loss unless the notice was sent or published within the required 20 days.

**480.7(3) Certificate of disposal.** A private entity shall submit with the abandoned vehicle report a copy of the completed certificate of disposal.

**480.7(4) Receipts.** The police authority or private entity shall submit with the abandoned vehicle report detailed receipts showing payment for each expense incurred. A receipt must identify the date(s) of occurrence of the expense; for example, a receipt for storage must identify the beginning and ending dates. A receipt for both towing and storage must show separately the towing charge and the storage charge per day. Reimbursement shall be limited as follows:

- a. Towing—\$50 per vehicle.
- b. Notice—actual postage or publication cost.
- c. Storage—\$5 per day, not to exceed 45 days per vehicle.

(1) If a police authority provides its own storage facility for abandoned vehicles, the department shall not reimburse the police authority for use of that facility.

(2) When the vehicle is held for an evidentiary hearing for more than 45 days, the police authority or private entity shall submit proof of the evidentiary hearing to obtain reimbursement.

d. Advertising—up to \$20 per auction, or advertising receipt totals for two auctions, whichever is less, not to exceed \$40 total.

e. Auction expenses—10 percent of the vehicle's sale price or \$10 per vehicle, whichever is less. A receipt is not required for auction expense reimbursement.

**480.7(5) Towing only.** To request reimbursement of only the towing expense, the police authority shall report the abandoned vehicle to the department on the prescribed abandoned vehicle report form. The form shall be accompanied by a receipt showing payment for the towing expense incurred. Reimbursement for towing is limited to \$50 per vehicle.

[ARC 5257C, IAB 11/4/20, effective 12/9/20]

#### **761—480.8(321) Time limits.**

**480.8(1) Report claiming reimbursement.** A claim for reimbursement must be submitted to the department within 90 days after the sale or disposal of the abandoned vehicle.

**480.8(2) Report remitting unclaimed profits.**

a. If proceeds from the sale or disposal of a vehicle are not claimed by the owner or lienholder(s) during the specified 90 days, the police authority shall send the proceeds to the department within 10 days after the claiming period expires.

b. If personal property is disposed of pursuant to Iowa Code section 321.89, the proceeds are exempt from this rule.

[ARC 5257C, IAB 11/4/20, effective 12/9/20]

These rules are intended to implement Iowa Code sections 321.71, 321.89 and 321.90.

[Filed 11/22/77, Notice 10/5/77—published 12/14/77, effective 1/18/78]

[Filed 9/9/81, Notice 7/22/81—published 9/30/81, effective 11/4/81]

[Filed 1/21/83, Notice 12/8/82—published 2/16/83, effective 3/23/83]

[Filed 1/9/85, Notice 11/21/84—published 1/30/85, effective 3/6/85]

[Filed 5/11/87, Notice 3/11/87—published 6/3/87, effective 7/8/87]

[Filed 12/15/88, Notice 11/2/88—published 1/11/89, effective 2/15/89]

[Filed emergency 11/30/89—published 12/27/89, effective 12/1/89]

[Filed 1/15/92, Notice 12/11/91—published 2/5/92, effective 3/11/92]

[Filed 6/28/95, Notice 5/10/95—published 7/19/95, effective 8/23/95]

[Filed 11/20/96, Notice 10/9/96—published 12/18/96, effective 1/22/97]

[Filed 3/11/98, Notice 1/28/98—published 4/8/98, effective 5/13/98]

[Filed 10/11/07, Notice 8/15/07—published 11/7/07, effective 12/12/07]

[Editorial change: IAC Supplement 12/30/09]

[Filed ARC 9048B (Notice ARC 8869B, IAB 6/30/10), IAB 9/8/10, effective 10/13/10]

[Filed ARC 5257C (Notice ARC 5170C, IAB 9/9/20), IAB 11/4/20, effective 12/9/20]



CHAPTERS 481 to 499  
Reserved



## MOTOR CARRIERS

## CHAPTER 500

## INTERSTATE REGISTRATION AND OPERATION OF VEHICLES

[Prior to 6/3/87, Transportation Department[820]—(07,F) Ch 1]

**761—500.1(326) Definitions.** The definitions in Iowa Code sections 326.2 and 326.3 apply to this chapter. In addition:

“*Distance schedule*” means the department form used to report fleet distance.

“*IRP*” means the International Registration Plan as defined in Iowa Code section 326.2.

“*Qualified registrant*” means a motor carrier who has received written approval by the department to self-certify IRP credential destruction.

“*Self-certification of IRP credential destruction*” means a signed statement that is completed by a qualified registrant certifying the date the IRP credentials have been destroyed.

“*Temporary evidence of apportioned registration*” means a document issued by the department that describes the vehicle and lists the weight for each jurisdiction in which the vehicle is registered for operation and allows the vehicle to be operated.

“*Vehicle schedule*” means the department form used to report vehicle registration information.

This rule is intended to implement Iowa Code sections 326.2, 326.3, 326.15 and 326.33.

[ARC 5494C, IAB 3/10/21, effective 4/14/21]

**761—500.2(17A,326) General information.**

**500.2(1) Information and location.** Applications, forms and information on interstate registration and operation of vehicles are available on the department’s website at [www.iowadot.gov](http://www.iowadot.gov), by mail from the Vehicle and Motor Carrier Services Bureau, Iowa Department of Transportation, P.O. Box 10382, Des Moines, Iowa 50306-0382; in person at 6310 SE Convenience Blvd., Ankeny, Iowa; by telephone at (515)237-3268; by facsimile at (515)237-3225; or by email at [omcs@iowadot.us](mailto:omcs@iowadot.us).

**500.2(2) Method of operation.** The operations of the department’s motor vehicle division relating to reciprocity and apportioned registration shall be conducted in accordance with the IRP and Iowa Code chapters 321 and 326.

**500.2(3) Organizational data.** The vehicle and motor carrier services bureau of the motor vehicle division is authorized pursuant to Iowa Code chapter 326 to:

*a.* Enter into reciprocity apportioned registration agreements with other jurisdictions. The department is a member of the IRP. The IRP and any revisions thereto are hereby incorporated into this chapter. A copy of the agreement may be obtained by contacting the vehicle and motor carrier services bureau or at [www.irponline.org](http://www.irponline.org). Under this agreement, the vehicle and motor carrier services bureau shall do all of the following:

(1) Compute and collect apportionable fees due this state under apportioned registration agreements.

(2) Issue registration plates, validation stickers, cab cards, temporary evidence of apportioned registration, and trip permits to qualified registrants.

(3) Enter into reciprocity agreements with other jurisdictions. These agreements exempt nonresidents from the registration and registration fee requirements of Iowa Code chapter 321.

This rule is intended to implement Iowa Code sections 17A.3, 326.5 and 326.6.

[ARC 5494C, IAB 3/10/21, effective 4/14/21]

**761—500.3(17A,326) Waiver of rules.** In accordance with 761—Chapter 11, the director of transportation may, in response to a petition, waive provisions of this chapter. A waiver shall not be granted unless the director finds that special or emergency circumstances exist. “Special or emergency circumstances” means one or more of the following:

**500.3(1)** Circumstances where the movement is necessary to cooperate with cities, counties, other state agencies or other states in response to a national or other disaster.

**500.3(2)** Circumstances where the movement is necessary to cooperate with national defense officials.

**500.3(3)** Circumstances where the movement is necessary to cooperate with public or private utilities in order to maintain their public services.

**500.3(4)** Circumstances where the movement is essential to ensure safety and protection of any person or property due to events such as, but not limited to, pollution of natural resources, a potential fire or explosion.

**500.3(5)** Circumstances where weather or transportation problems create an undue hardship for citizens of the state of Iowa.

**500.3(6)** Circumstances where movement involves emergency-type vehicles.

**500.3(7)** Uncommon or extraordinary circumstances where the movement is essential to the existence of an Iowa business and the move may be accomplished without causing undue hazard to the safety of the traveling public or undue damage to private or public property.

This rule is intended to implement Iowa Code sections 17A.9A and 326.33.

**761—500.4(326) Renewal for IRP registration.** Renewal reminder notices are sent electronically or by mail at least 60 days prior to the registration expiration date to all registrants who maintained an active IRP fleet with Iowa during that year. A registrant may request a renewal reminder notice to be sent by mail. The renewal is made available online at least 60 days prior to the registration expiration date and can be accessed on the department's website.

**500.4(1)** The renewal must include:

*a.* A completed and signed distance schedule and vehicle schedule(s). The schedules can be filed and signed either electronically or on paper.

*b.* Title documentation, if necessary.

*c.* One of the following:

(1) Receipted federal heavy vehicle use tax (Form 2290 Schedule 1) for vehicles with a taxable gross weight of 55,000 pounds or more.

(2) A copy of Form 2290 Schedule 1 and sufficient documentation of payment of the tax due at the time Form 2290 was filed. The documentation can include, but is not limited to, a photocopy of both sides of a canceled check, a bank statement indicating the amount of tax paid and electronic acknowledgment indicating a payment of tax, and an Internal Revenue Service printout of the taxpayer's account showing the amount of tax paid.

**500.4(2)** Additional renewal procedures.

*a.* Vehicles may be deleted from the fleet at the time of renewal. Operating a vehicle with credentials marked as deleted shall result in the registrant being responsible for any fees assessed including any applicable penalty. Operating a vehicle with credentials that were self-certified as destroyed shall result in suspension of the self-certification privilege.

*b.* Units being stored shall be marked "stored" on the renewal vehicle schedule and the plates, cab cards and validation stickers must be returned in accordance with rule 761—500.5(321).

*c.* Vehicles may be added at the time of renewal. Upon payment of required fees, an applicant must apply for a temporary evidence of apportioned registration to be issued to operate a vehicle in accordance with the IRP. The department may extend the temporary evidence of apportioned registration if there are extenuating circumstances beyond the applicant's control.

*d.* When the registrant is seeking a refund in accordance with Iowa Code section 326.15 for vehicles deleted at the time of renewal, the annual and permanent registration plates and validation stickers must be returned to the vehicle and motor carrier services bureau.

This rule is intended to implement Iowa Code sections 326.6, 326.11, 326.12, 326.14 and 326.15.

[ARC 5494C, IAB 3/10/21, effective 4/14/21]

**761—500.5(321) Deadline for placing a vehicle in storage.** The registrant of a currently registered vehicle may at any time request that a vehicle be put into storage. The registrant must complete a vehicle schedule and return it with the plate, cab card and validation sticker to the vehicle and motor carrier services bureau. The vehicle schedule, plate, cab card and sticker must be received or postmarked on or before the registration expiration date to stop the registration fee from being assessed for the renewal year. The vehicle and motor carrier services bureau shall destroy the plate and return the cab card to the registrant with the word "stored" stamped on it. Placing the vehicle in storage stops penalties on registration fees. When the vehicle is taken out of storage, the vehicle shall be assessed for the current annual registration fee.

This rule is intended to implement Iowa Code sections 321.126 and 321.134.

[ARC 5494C, IAB 3/10/21, effective 4/14/21]

**761—500.6(321,326) Payment, delinquency and suspension.**

**500.6(1)** Payment shall be made payable to the Iowa Department of Transportation by cash, check, credit card, or any other means offered by the department. Payment shall be due 30 calendar days from the invoice date. However, renewal invoices shall be due 30 calendar days from the invoice date or by the last day of the registration expiration month, whichever is later.

**500.6(2)** Invoices not paid by the due date shall be assessed a late payment penalty as provided in Iowa Code sections 326.14 and 326.16. The same penalty amount will be assessed the first of each month thereafter until the total invoice and all penalties are paid in full.

**500.6(3)** A delinquency notice shall be sent on invoices 30 calendar days overdue. The department shall send a delinquency notice stating the IRP registration shall be suspended unless payment is received within 30 calendar days from the date of the delinquency notice. If payment is not received in a timely manner, a notice of suspension shall be sent to the registrant. When a registrant is under suspension, all of the registrant's Iowa-based IRP vehicles shall be suspended.

This rule is intended to implement Iowa Code sections 326.10A, 326.14 and 326.16.

[ARC 5494C, IAB 3/10/21, effective 4/14/21]

**761—500.7(326) Self-certification of IRP registration plate and validation sticker destruction.**

**500.7(1)** In order to request a refund for unused registration fees, unless the registrant qualifies to self-certify destruction under this rule, plates and validation stickers must be returned to the department when a vehicle is deleted from the fleet. A registrant must meet all of the following requirements to qualify for department approval to self-certify destruction of IRP credentials:

a. A minimum of five years' experience with IRP registration.

b. A satisfactory IRP payment history. A satisfactory payment history includes, but is not limited to, no suspension of IRP registration in the last five years due to late payment or returned check because of insufficient funds.

c. A satisfactory rating from the U.S. Department of Transportation in the previous five years.

**500.7(2)** A motor carrier subject to a federal out-of-service order in the current year or any of the four prior years shall not be eligible to self-certify IRP credential destruction.

This rule is intended to implement Iowa Code section 326.15.

[ARC 5494C, IAB 3/10/21, effective 4/14/21]

**761—500.8(326) IRP credentials.** Upon payment of appropriate fees and submission of all required documentation, the vehicle and motor carrier services bureau shall issue one IRP plate for each power unit to be mounted on the front of the power unit, one trailer plate to be mounted on the rear of the trailer, and one cab card for each power unit. The cab card may be in either a physical or electronic format.

This rule is intended to implement Iowa Code section 326.14.

[ARC 5494C, IAB 3/10/21, effective 4/14/21]

**761—500.9(326) Nonrenewal vehicle additions.** A registrant may add a vehicle to the fleet at any time after the commencement of the registration year. Upon payment of required fees, temporary evidence of apportioned registration may be issued to operate the vehicle(s). The temporary evidence of apportioned registration shall not exceed 45 days. However, the department may extend the temporary evidence of apportioned registration for up to a total of 60 days if there are extenuating circumstances. Once temporary evidence of apportioned registration is issued and used, fees shall be due and the invoice may only be canceled if an error was made by the department or there were extenuating circumstances for which nonuse can be proven.

This rule is intended to implement Iowa Code section 326.11.

[ARC 5494C, IAB 3/10/21, effective 4/14/21]

**761—500.10(326) Nonrenewal vehicle deletions.** A registrant may delete vehicles from the fleet at any time after the commencement of the registration year. The plates and validation stickers must be returned to the vehicle and motor carrier services bureau at the time of deletion. In lieu of returning the plates and validation stickers, a qualified registrant under rule 761—500.7(326) may submit a self-certification of IRP credential destruction on or before the vehicle(s) deletion date to the vehicle and motor carrier services bureau. Operating a vehicle with credentials that were self-certified as destroyed shall result in suspension of the self-certification privilege, and the registrant shall be responsible for any additional fees that would have been due beyond the stated destruction date.

This rule is intended to implement Iowa Code sections 326.12 and 326.15.

[ARC 5494C, IAB 3/10/21, effective 4/14/21]

**761—500.11(326) Voluntary cancellation of registration.** A registrant may cancel an application for IRP registration if the registrant notifies the vehicle and motor carrier services bureau within 15 days of the invoice date. The notice shall state the reason for cancellation, the licensing status and ownership and be signed by the registrant or its representative. If notice is not received within 15 days or if a temporary evidence of apportioned registration was issued in accordance with 761—500.9(326), all registration fees must be paid in full.

This rule is intended to implement Iowa Code sections 326.6 and 326.11.

[ARC 5494C, IAB 3/10/21, effective 4/14/21]

**761—500.12(326) Policy on registration credit.** If a vehicle is deleted from the IRP fleet and replaced with another vehicle, registration credit may be applied to IRP fees due on the replacement vehicle. The vehicle schedule identifying the added and deleted vehicles must be submitted to the vehicle and motor carrier services bureau. The deletion must take place on or before the effective date of the replacement vehicle's registration. Allowance for credit of deleted vehicles shall be subject to the conditions set forth in Iowa Code section 326.12.

This rule is intended to implement Iowa Code section 326.12.

[ARC 5494C, IAB 3/10/21, effective 4/14/21]

**761—500.13(326) Penalty for late filing of vehicle schedule.**

**500.13(1)** As provided in Iowa Code sections 326.14 and 326.16, a late filing penalty of 5 percent shall be assessed to the vehicle if a vehicle schedule is not filed within 30 days of:

- a. The purchase of a new or used vehicle;
- b. The date a vehicle is brought across state borders into Iowa to be registered; or
- c. A vehicle being first operated with the exemption allowed under Iowa Code section 321.20A.

**500.13(2)** An additional penalty shall be assessed on the first of each month thereafter until the vehicle schedule is filed.

**500.13(3)** The department may collect intrastate registration fees and penalties when registering a delinquent vehicle to bring the vehicle fees current before allowing the IRP registration of the vehicle.

This rule is intended to implement Iowa Code sections 321.20A, 326.11, 326.14 and 326.16.

[ARC 5494C, IAB 3/10/21, effective 4/14/21]

**761—500.14(326) Renewal and vehicle schedule late payment penalty.** Rescinded ARC 5494C, IAB 3/10/21, effective 4/14/21.

**761—500.15(321) Deadline for payment of first-half fee.** Rescinded ARC 5494C, IAB 3/10/21, effective 4/14/21.

**761—500.16(321,326) Second-half late payment penalty.** Rescinded ARC 5494C, IAB 3/10/21, effective 4/14/21.

**761—500.17(326) Duplicate credentials.** The fees for duplicate credentials are as follows:

**500.17(1)** A replacement cab card is \$3.

**500.17(2)** A replacement plate including the cab card is \$8.

**500.17(3)** If applicable, a mailing fee will also be assessed based on the number of plates or cab cards being issued.

This rule is intended to implement Iowa Code section 326.22.

[ARC 5494C, IAB 3/10/21, effective 4/14/21]

**761—500.18(326) Suspension for nonpayment of registration fees.** Rescinded ARC 5494C, IAB 3/10/21, effective 4/14/21.

**761—500.19(326) Suspension of registration if payment is dishonored by a financial institution.** Rescinded ARC 5494C, IAB 3/10/21, effective 4/14/21.

**761—500.20(326) Making claim for refund.** A refund of Iowa fees previously paid for the registration of vehicles may be made in accordance with Iowa Code sections 321.126, 321.127, 321.129 and 326.15. A claim for refund form may be obtained from the vehicle and motor carrier services bureau. In lieu of returning the plates, a qualified registrant may submit a self-certification of IRP credential destruction on or before the vehicle's deletion date to the vehicle and motor carrier services bureau.

This rule is intended to implement Iowa Code sections 321.126, 321.127, 321.129 and 326.15.

[ARC 5494C, IAB 3/10/21, effective 4/14/21]

**761—500.21(326) Registration expiration and enforcement dates.** Rescinded ARC 5494C, IAB 3/10/21, effective 4/14/21.

**761—500.22(326) Registration of vehicles with non-Iowa titles.** Registrants applying for registration for non-Iowa titled vehicles shall submit to the vehicle and motor carrier services bureau with the application or payment as specified in rule 761—500.7(326) either a copy of the non-Iowa title or a copy of the title application if the title has not been issued. If a jurisdiction does not issue titles, a copy of the bill of sale or a copy of the Canadian registration shall accompany the application or payment.

This rule is intended to implement Iowa Code section 326.11.

[ARC 5494C, IAB 3/10/21, effective 4/14/21]

**761—500.23(326) Record retention.**

**500.23(1) *Record retention requirement and penalty.*** Iowa IRP registrants shall preserve the records upon which their registration is based as required by the IRP for the current registration year and the three preceding registration years. On request, the registrant shall make such records available for audit. The department may assess a penalty upon registrants who have failed to maintain proper records.

**500.23(2) *Adequacy of records.*** The records maintained by a registrant shall be adequate to enable the department to verify the distances reported in the registrant's application for apportioned registration and to evaluate the accuracy of the registrant's distance accounting system. The records may be produced through any means and retained in any format or medium available to the registrant and accessible by the department.

*a.* The following records produced by a means other than a vehicle-tracking system shall be considered adequate:

(1) The beginning and ending dates of the trip to which the records pertain.

(2) The origin and destination of the trip.

(3) The route of travel.

(4) The beginning and ending reading from the odometer, hubodometer, engine control module (ECM), or any similar device for the trip.

(5) The total distance of the trip.

(6) The distance traveled in each jurisdiction.

(7) The vehicle identification number or vehicle unit number.

*b.* The following records produced wholly or partly by a vehicle-tracking system, including a system based on a global positioning system (GPS) shall be considered adequate under this subrule:

(1) The original GPS or other location data for the vehicle to which the records pertain.

(2) The date and time of each GPS reading or other system reading.

(3) The location of each GPS reading or other system reading.

(4) The beginning and ending reading from the odometer, hubodometer, engine control module (ECM), or any similar device for the period to which the records pertain.

(5) The calculated distance between each GPS reading or other system reading.

(6) The route of the vehicle's travel.

(7) The total distance traveled by the vehicle.

(8) The distance traveled in each jurisdiction.

(9) The vehicle identification number or vehicle unit number.

**500.23(3) *Summaries.*** The following summaries shall be maintained:

*a.* A summary of the fleet's operations of each month, which includes both the full distance traveled by each apportioned vehicle in the fleet during the calendar month and the distance traveled in the month by each apportioned vehicle in each jurisdiction.

*b.* A summary of the fleet's operations for each calendar quarter, which includes both the full distance traveled by vehicles in the fleet during the calendar quarter and the distance traveled in each jurisdiction by the vehicles in the fleet during the calendar quarter.

This rule is intended to implement Iowa Code section 326.19A.

[ARC 5494C, IAB 3/10/21, effective 4/14/21]

**761—500.24(326) Trip permits.** The registrants may meet the registration requirements of Iowa Code chapter 326 by operating under a trip permit. However, moves that are intrastate or exceed legal dimensions or weight and operate under permit as specified in Iowa Code chapter 321E shall not be allowed.

**500.24(1)** Trip permits may be obtained through the department's website, by mail, or in person from the vehicle and motor carrier services bureau. Such requests shall include the appropriate permit fee remittance.

**500.24(2)** Registrants purchasing trip permits in advance of use may not return unused permits for a refund.

This rule is intended to implement Iowa Code sections 326.23 and 326.46.

[ARC 5494C, IAB 3/10/21, effective 4/14/21]

**761—500.25(326) Electronic information.** To the greatest extent possible, the vehicle and motor carrier services bureau shall maintain in electronic form all records required under this chapter. The retention period for electronic records must follow the guidelines of the IRP.

**500.25(1)** *IRP vehicle transaction.* The vehicle and motor carrier services bureau shall destroy paper copies of IRP vehicle transaction requests 90 days after the IRP invoice is generated.

**500.25(2)** *Federal heavy use tax (Form 2290 Schedule 1).* The vehicle and motor carrier services bureau shall maintain Form 2290 Schedule 1 in accordance with 23 CFR Section 669.9.

This rule is intended to implement Iowa Code section 326.33.

[ARC 5494C, IAB 3/10/21, effective 4/14/21]

[Filed July 1, 1975]

[Filed without Notice, 6/8/76—published 6/28/76, effective 8/2/76]

[Filed 11/22/76, Notice 10/6/76—published 12/15/76, effective 1/19/77]

[Filed 10/17/77, Notice 8/24/77—published 11/2/77, effective 12/7/77]

[Filed 12/19/77, Notice 10/19/77—published 1/11/78, effective 2/15/78]

[Filed 10/5/79, Notice 8/22/79—published 10/31/79, effective 12/5/79]

[Filed 10/17/80, Notices 8/20/80, 9/17/80—published 11/12/80, effective 12/17/80]

[Filed 12/2/81, Notice 9/30/81—published 12/23/81, effective 1/27/82]

[Filed 2/7/83, Notice 12/22/82—published 3/2/83, effective 4/6/83]

[Filed 3/9/84, Notice 1/18/84—published 3/28/84, effective 5/2/84]

[Filed 5/11/87, Notice 3/11/87—published 6/3/87, effective 7/8/87]

[Filed emergency 11/30/89—published 12/27/89, effective 12/1/89]

[Filed emergency 3/26/92—published 4/15/92, effective 4/29/92]

[Filed 4/8/93, Notice 3/3/93—published 4/28/93, effective 6/2/93<sup>1</sup>]

[Filed 11/7/02, Notice 10/2/02—published 11/27/02, effective 1/1/03]

[Filed 9/24/03, Notice 8/20/03—published 10/15/03, effective 11/19/03]

[Filed 11/19/04, Notice 10/13/04—published 12/22/04, effective 1/26/05]

[Filed 6/15/05, Notice 5/11/05—published 7/6/05, effective 8/10/05]

[Filed 9/14/05, Notice 8/3/05—published 10/12/05, effective 11/16/05]

[Filed 12/12/07, Notice 11/7/07—published 1/2/08, effective 2/6/08]

[Filed ARC 5494C (Notice ARC 5340C, IAB 12/30/20), IAB 3/10/21, effective 4/14/21]

<sup>1</sup> Effective date of 500.1, definition of "Power unit," 500.2, 500.3(1), 500.3(3), introductory paragraph, 500.3(3)"a" and "c," 500.3(4)"a," introductory paragraph, 500.3(4)"c," 500.3(5)"a," introductory paragraph, 500.3(5)"a"(2), 500.3(5)"b"(2), 500.3(6), 500.6 to 500.9, 500.11, 500.12, 500.14, 500.17, 500.20, June 2, 1993, delayed 70 days by the Administrative Rules Review Committee at its meeting held May 12, 1993; delay lifted by this Committee June 8, 1993, effective June 9, 1993.

CHAPTERS 501 to 504  
Reserved



CHAPTER 505  
INTERSTATE MOTOR VEHICLE FUEL LICENSES AND PERMITS

[Prior to 6/3/87, Transportation Department[820]—(07,F) Ch7]

**761—505.1(452A) Definitions.**

“*Department*” means the Iowa department of transportation.

“*Electric fuel*” means electrical energy delivered or placed into the battery or other energy storage device of an electric motor vehicle from a source outside the motor vehicle for purposes of propelling the motor vehicle as defined in Iowa Code section 452A.40 as enacted by 2019 Iowa Acts, House File 767, section 23.

“*Fuel supply tank*” means a motor vehicle’s hydrogen fuel cells if the motor vehicle uses hydrogen as a special fuel.

“*Fuel(s)*” means and includes motor fuel and special fuel as defined in Iowa Code section 452A.2.

“*Fuel license*” or “*license*” means an International Fuel Tax License issued pursuant to Iowa Code section 452A.53.

“*Hydrogen gallon*” means a diesel gallon equivalent. A diesel gallon equivalent of hydrogen weighs 2.49 pounds.

“*IFTA member jurisdiction*” means a jurisdiction that is a member of the International Fuel Tax Agreement. A list of jurisdictions and their membership statuses may be obtained by contacting the vehicle and motor carrier services bureau.

“*International Fuel Tax Agreement (IFTA)*” is a multijurisdiction agreement for the administration of motor fuel tax laws for vehicles operated in multiple member jurisdictions.

“*Lease*” means a contract or agreement by which a vehicle owner (lessor) provides a vehicle to a person or company (lessee) for use during a specified period of time.

1. “*Long-term lease*” means a lease for a period of 30 days or more.

2. “*Short-term lease*” means a lease for a period of 29 days or less including trip leases. Back-to-back leases of 29 days or less are considered short-term leases.

“*Licensee*” means any person who holds a valid fuel license.

“*Non-IFTA member jurisdiction*” means a jurisdiction that is not a member of the International Fuel Tax Agreement. A list of jurisdictions and their membership statuses may be obtained by contacting the vehicle and motor carrier services bureau.

“*Permittee*” means any person who holds a valid temporary fuel permit.

“*Qualified motor vehicle*” means a motor vehicle or combination of vehicles used or designed to transport persons or property if any of the following apply:

1. The vehicle or combination of vehicles weighs more than 26,000 pounds.

2. The vehicle or combination of vehicles is registered for more than 26,000 pounds.

3. The power unit has three or more axles.

“Qualified motor vehicle” does not include recreational vehicles.

“*Quarter*” means calendar quarter, January 1 to March 31, April 1 to June 30, July 1 to September 30, and October 1 to December 31.

“*Temporary fuel permit*” or “*temporary permit*” means a single trip fuel permit issued pursuant to Iowa Code section 452A.53.

In addition to the preceding definitions, all of the definitions contained in Iowa Code sections 452A.2 and 452A.57 shall govern the rules in this chapter, where not inconsistent with the above definitions.

This rule is intended to implement Iowa Code sections 452A.2 and 452A.57 and section 452A.40 as enacted by 2019 Iowa Acts, House File 767, section 23.

[ARC 5178C, IAB 9/9/20, effective 10/14/20]

**761—505.2(452A) General information.**

**505.2(1) Information and location.** Applications, forms and information on interstate motor vehicle fuel permits and licenses are available by mail from the Vehicle and Motor Carrier Services Bureau, Iowa Department of Transportation, P.O. Box 10382, Des Moines, Iowa 50306-0382; in person at 6310 SE Convenience Blvd., Ankeny, Iowa; by telephone at (515)237-3268; by facsimile at (515)237-3225; by email at [omcs@iowadot.us](mailto:omcs@iowadot.us); or on the department’s website at [www.iowadot.gov](http://www.iowadot.gov).

**505.2(2) Organizational data.** The vehicle and motor carrier services bureau is authorized, pursuant to Iowa Code chapter 452A, division III, to:

a. Issue fuel licenses or temporary fuel permits.

b. Compute and collect interstate motor fuel taxes.

c. Refund overpayments of interstate fuel taxes.

d. Administer agreements with other jurisdictions for the collection and refund of interstate motor fuel tax. In accordance with this, the department has adopted the International Fuel Tax Agreement (IFTA). Such agreement and any revisions thereto are hereby incorporated into this chapter. International Fuel Tax Agreement governing documents do not create rights in the taxpayer. A copy of the agreement may be reviewed at [www.iftach.org](http://www.iftach.org).

**505.2(3) Waiver of rules.** In accordance with 761—Chapter 11, the director of transportation may, in response to a petition, waive provisions of this chapter. A waiver shall not be granted unless the director finds that special or emergency circumstances exist.

“Special or emergency circumstances” means one or more of the following:

a. Circumstances where the movement is necessary to cooperate with cities, counties, other state agencies or other states in response to a national or other disaster.

b. Circumstances where the movement is necessary to cooperate with national defense officials.

c. Circumstances where the movement is necessary to cooperate with public or private utilities in order to maintain their public services.

d. Circumstances where the movement is essential to ensure safety and protection of any person or property due to events such as, but not limited to, pollution of natural resources, a potential fire or an explosion.

e. Circumstances where weather or transportation problems create an undue hardship for citizens of the state of Iowa.

f. Circumstances where the movement involves emergency-type vehicles.

g. Uncommon or extraordinary circumstances where the movement is essential to the existence of an Iowa business and the move may be accomplished without causing undue hazard to the safety of the traveling public or undue damage to private or public property.

This rule is intended to implement Iowa Code sections 452A.51 and 452A.56.

[ARC 5178C, IAB 9/9/20, effective 10/14/20]

#### **761—505.3(452A) General stipulations.**

**505.3(1) IFTA member requirements.** In order to enter this state and not be in violation of Iowa Code section 452A.52, the operator of the qualified motor vehicle based in an IFTA member jurisdiction must do one of the following:

a. Possess a fuel license pursuant to Iowa Code section 452A.53.

b. Purchase a temporary fuel permit pursuant to Iowa Code section 452A.53 and subrule 505.3(9) when entering or before entering the state.

**505.3(2) Non-IFTA member requirements.** The operator of a qualified motor vehicle based in a non-IFTA member jurisdiction must do one of the following:

a. Possess a fuel license pursuant to Iowa Code section 452A.53.

b. Purchase a temporary fuel permit pursuant to Iowa Code section 452A.53 and subrule 505.3(9) when entering or before entering the state.

c. Enter the state with 30 gallons of fuel or less.

d. On or after July 1, 2023, enter the state with less than 350 kilowatt hours of electric fuel.

e. Enter the state with only Iowa tax paid fuel.

**505.3(3) Determination of fuel supply.**

a. To determine if a vehicle has entered the state with more than 30 gallons of fuel, the total of all fuel in all tanks that could be used to fuel the power source of the vehicle shall be considered to reach a total gallonage, or diesel gallon equivalent. The fuel tank connected to a “reefer unit” which can neither be directly nor indirectly connected to the power source of the vehicle shall not be considered in arriving at the 30-gallon total.

b. To determine if a vehicle has entered the state with more than 350 kilowatt hours of electric fuel, the total of all electric fuel in the batteries or other energy storage devices of a commercial motor vehicle shall be considered to reach total kilowatt hours, regardless of whether the batteries or storage devices are connected to the motor of the vehicle.

**505.3(4) Fuel license.**

a. A fuel license may be obtained from the vehicle and motor carrier services bureau at a cost of \$10. The application must be complete and include the following information:

- (1) Name and address of company, corporation, or owner who operates or controls the qualified motor vehicle(s);
- (2) Name(s) and address(es) of principal or corporate officers;
- (3) Signature and telephone number of contact person;

(4) A power of attorney if someone other than an officer or employee of the company will be completing quarterly reports or requesting information from the department; and

(5) Any other information required by the department.

b. The fuel license remains valid until canceled or revoked. The reporting and computation procedure for a fuel license allows for the payment of taxes due and a refund of any overpayment. All persons holding a valid fuel license must file quarterly reports with the department.

**505.3(5)** *Number of temporary permits or licenses required.* No vehicle may operate under more than one license or temporary permit at a time.

**505.3(6)** *Possession of the license or temporary permit.* A license or temporary permit must be carried in the vehicle to meet the requirements of Iowa Code chapter 452A. More than one vehicle may be operated and reported under the same license by making a photocopy of the license and carrying it in each vehicle operating under said license. A license, copy of a license or temporary permit is void if altered. A duplicate license may be purchased from the vehicle and motor carrier services bureau for 50 cents.

**505.3(7)** *Cancellation and reissuance.*

a. If a qualified motor vehicle operating under a license is consistently operated only within the state or only outside the state, the licensee or the department shall request that the license be canceled for nonuse.

b. A fuel license that has been canceled for cause pursuant to Iowa Code section 452A.68 may be reinstated if a bond is filed.

**505.3(8)** *Bond requirements.*

a. Bonds shall be required in the following situations:

(1) When a previous fuel licensee is reapplying for a fuel license and has two or more outstanding fuel billings due for periods within the three years prior to date of application for a new license;

(2) When a previous fuel licensee is reapplying for a new fuel license and has failed to file two or more reports for a calendar year within the three years prior to date of application for a new license;

(3) When a previous fuel licensee is reapplying for a new license and has filed reports late for two or more reporting periods for a calendar year within the three years prior to date of application for a new fuel license; or

(4) When an audit indicates problems severe enough that a bond is required to protect the interests of member jurisdictions.

b. Bonds required shall be payable to the state of Iowa, in the minimum amount of \$500 or the equivalent to at least twice the estimated average tax liability for the reporting period in which the licensee will be required to file a tax return, whichever is greater.

c. A copy of such bond shall be filed with the vehicle and motor carrier services bureau before a new license shall be issued. The vehicle and motor carrier services bureau shall be notified of bond cancellation 30 days before the cancellation is effective.

**505.3(9)** *Temporary fuel permits.*

a. A temporary fuel permit may be obtained by any person operating a qualified motor vehicle that is not otherwise covered by a license. The temporary permit may be obtained from the vehicle and motor carrier services bureau at a cost of \$20. The temporary permit may also be obtained from permit services or processing agents. An application for a temporary permit may be made by phone, by facsimile or electronically to the vehicle and motor carrier services bureau. Permittees who purchase temporary fuel permits in advance of use may not return unused permits for refund.

b. The temporary fuel permit is valid for 72 consecutive hours from the date and hour appearing on the temporary permit or upon departure from Iowa, whichever occurs first. A new temporary permit is required in order to reenter the state. While a permittee is operating under a temporary permit, unlimited travel is allowed within Iowa. No refund of tax paid on overpurchases of Iowa fuel is allowed.

c. An application for a temporary fuel permit shall include, but is not limited to, the following information:

(1) The name and address of the person who owns or controls the vehicle;

(2) The make, year, serial number, license number, and unit number of the vehicle; and

(3) The address to which the temporary permit is to be sent, if applicable.

d. The temporary permit fee shall also accompany the application unless a method of collection upon delivery is requested.

e. A temporary permit shall not be transferred and is valid only for the carrier and the vehicle that are described on the permit. Once a temporary permit has been issued to a qualified motor vehicle, the purchase price is nonrefundable.

f. The temporary permit must be completed and carried in the qualified motor vehicle for which it is issued.

g. The 72-hour period for which the temporary permit is valid may be extended for “emergencies,” such as extreme weather conditions when travel is not advisable or other instances, at the discretion of the vehicle and motor carrier services bureau.

h. A temporary fuel permit is invalid if the permittee has outstanding IFTA fuel tax bills.

i. Fees for a temporary permit may be paid by cash, company or personal check, or credit card.

**505.3(10) *Qualified motor vehicles on lease.***

a. *Long-term lease.* Under normal circumstances the lessee is responsible for reporting all mileage and fuel activity unless otherwise specified by the lease. Supporting documentation including the lease must be made available to confirm the responsibility.

b. *Short-term lease.* The lessor is responsible for reporting all mileage and fuel activity unless otherwise specified by the lease. Supporting documentation such as a maintenance agreement or lease must be made available to confirm the responsibility.

c. *Purchase receipts.* Purchase receipts must be made out in the name of the lessor, lessee or cash and must identify the vehicle for which the purchase is made by showing one of the following: vehicle license number, full vehicle identification number (VIN) or fleet unit number.

This rule is intended to implement Iowa Code sections 452A.52, 452A.53, 452A.54, 452A.58 and 452A.68.

[ARC 5178C, IAB 9/9/20, effective 10/14/20]

**761—505.4(452A) Quarterly reports.**

**505.4(1) *Failure to file.*** All valid fuel licensees shall file quarterly reports with the department. If a licensee has not traveled in Iowa, the report shall still be filed. Failure to file is cause for revocation of the license and assessment of a penalty.

**505.4(2) *Filing deadline.*** All persons holding a valid fuel license, pursuant to the provisions of Iowa Code section 452A.53, shall file quarterly reports with the department and either remit any tax due no later than the last day of the month following the last day of the quarter covered by the report, or request a refund no later than the last day of the third month following the last day of the quarter covered by the report. If the claim for refund is filed after that date, the refund shall be disallowed.

**505.4(3) *Reporting multiple vehicles on single license.*** The licensee shall select which vehicles may be operated under the license. All miles traveled, interstate and intrastate, and all fuel purchased for those vehicles shall be reported on a consistent basis.

**505.4(4) *Tax refund.*** Refunds shall be computed separately for each fuel type. If a refund for a fuel type does not exceed \$10, it shall not be processed unless there is more than one type of fuel reported on one return and the combined refunds for all fuel types exceed \$10.

**505.4(5) *Refunds of tax on fuel purchased in Iowa and consumed out of Iowa.*** Even though fuel is purchased in Iowa, fuel tax is paid in Iowa, and the excess fuel tax paid is subject to refund under the provisions of Iowa Code chapter 452A, division III, relating to interstate motor vehicle operation, the refund is not subject to state sales tax.

**505.4(6) *Timely filing of report.***

a. The interstate fuel tax report required under Iowa Code section 452A.54 shall be deemed timely filed if received by the vehicle and motor carrier services bureau or postpaid, properly addressed, and postmarked by the United States Postal Service on or before midnight of the filing deadline. If the filing date falls on a Saturday, Sunday, or legal holiday, the next secular or business day shall be the filing deadline.

b. All reports and remittances shall be filed online at the department’s website; mailed to the Vehicle and Motor Carrier Services Bureau, Iowa Department of Transportation, P.O. Box 10382, Des Moines, Iowa 50306-0382; delivered in person to 6310 SE Convenience Blvd., Ankeny, Iowa; or sent by facsimile to (515)237-3225.

c. If a report or remittance is not received by the department and the taxpayer can prove by competent evidence that the return or remittance was timely filed, the report shall be considered timely filed. For the purpose of this rule, competent evidence means evidence in addition to the testimony of the sender sufficient or adequate to prove that the document was mailed on a specific date.

**505.4(7) *Extension of time to file.*** The department may grant an extension for the filing of any required report or tax payment. In order for an extension to be granted, the application requesting such extension must be filed with the department prior to the due date of the report or remittance. In determining whether an application for extension is timely filed, the provisions of subrules 505.4(2) and 505.4(6) shall apply. The application for extension shall be accompanied by an explanation of the circumstances justifying an extension. Any extension granted shall be documented on a form issued by the department indicating the length of the extension. This form shall be attached to the report when it is filed. If an extension is granted, the penalties under Iowa Code section 452A.65 applicable to a late-filed report or remittance shall not accrue until the expiration of the extension period.

**505.4(8) Penalties.**

a. A penalty of \$50 or 10 percent of the total tax due, whichever is greater, shall be assessed against the taxpayer if the report is not filed by the due date in accordance with subrule 505.4(6).

b. If the quarterly report shows no taxes owed or a refund due, the penalty for filing a report after the due date is \$50.

**505.4(9) Reserved.**

**505.4(10) Interest.** Interest at the rate established pursuant to Iowa Code chapter 421 shall be assessed against the taxpayer for each month the tax remains unpaid. The interest shall accrue from the date the return was required to be filed. Interest shall not apply to any penalty. Each fraction of a month shall be considered a full month for the computation of interest.

**505.4(11) Application of remittance.** All payments shall be first applied to the interest, then to the penalty and then the balance, if any, on the amount of tax then due.

If a taxpayer remits a payment on or before the due date, but the payment is insufficient to discharge the tax liability, the entire amount of such payment shall apply to the tax. Any penalty or interest subsequently assessed shall be based on the unpaid portion of the tax.

If the department determines there is additional tax due from a taxpayer, interest and penalty shall accrue on that amount from the date the tax should have been reported and paid.

**505.4(12) Reports, records and variations.** The department shall prescribe and furnish all forms upon which reports, claims for refund, temporary permits, and license applications shall be made under Iowa Code chapter 452A, division III.

a. If the information required in these documents is presented to the department on forms or in a manner other than on the prescribed form, the report, application or claim shall not be deemed "filed."

b. The fact that the reporting party does not have the prescribed form shall not be an acceptable reason for failure to file. The vehicle and motor carrier services bureau may be contacted to request copies of any necessary forms.

**505.4(13) Estimating gallonage or kilowatt hours used.**

a. In the event the taxpayer's records are lacking or inadequate to support any report filed or to determine the tax liability, the department is authorized to estimate the gallonage or kilowatt hours used upon which tax is due. This estimation shall be based upon such factors as, but not limited to, the following:

- (1) Prior experience of the taxpayer,
- (2) Taxpayers in similar situations,
- (3) Industry averages,
- (4) Records of suppliers or customers, or
- (5) Such other pertinent information as the department may possess, obtain or examine.

b. The findings of the department as to the amount of fuel taxes due from any person shall be presumed to be the correct amount and in any litigation which may follow, the certificate of the department shall be admitted in evidence, shall be considered to be true and accurate unless shown otherwise by an objecting party and shall impose upon the other party the burden of showing any error in the department's finding and the extent thereof, or showing that the finding was contrary to law.

**505.4(14) Information confidential.** Iowa Code section 452A.63, which makes all information obtained from reports or records required to be filed or kept under Iowa Code chapter 452A confidential, applies generally to the director, auditors, agents, officers, or other employees of the department. However, any person having acquired information disclosed in a taxpayer's filed report shall be bound by the same rules of confidentiality. The information may only be divulged to the appropriate public officials enumerated in Iowa Code section 452A.63.

**505.4(15) Taxes erroneously or illegally collected.** Any licensee shall be entitled to a refund of taxes, penalties, or interest erroneously or illegally collected by the department or as a result of a computation error. The claim must be filed within a year of payment and accompanied by evidence to support the claim. If the request for refund includes the return of penalties or interest, the interest or penalties shall be refunded in the same proportion as the tax.

**505.4(16) Supplemental billings.** The amount due is payable upon being billed by the vehicle and motor carrier services bureau. Billings shall be generated by the department for the collection of additional amounts due in the following circumstances:

- a. Penalties are assessed under the provisions of subrule 505.4(8).
- b. Interest is assessed under the provisions of subrule 505.4(10).
- c. An error in the computation on the front of the report results in additional tax due.
- d. There is a failure to remit payment for part or all of the tax due with the filed report.
- e. Payment is remitted and subsequently not honored.

*f.* Taxes, penalties or interest are assessed as the result of an audit.

This rule is intended to implement Iowa Code sections 452A.54, 452A.55, 452A.60, 452A.61, 452A.63, 452A.64, and 452A.65.

[ARC 5178C, IAB 9/9/20, effective 10/14/20]

**761—505.5(452A) Audits—required reports.**

**505.5(1)** *Delegation to audit and examine.* Pursuant to Iowa Code sections 452A.53, 452A.55, and 452A.62, the department reserves the right to examine returns and records, perform audits and determine the correct amount of tax due.

**505.5(2)** *Statute of limitations.* Within three years after a return is filed, the department may audit the return to determine the accuracy of taxes paid. There is no time limitation on collection activities for any tax, penalty or interest due the department.

**505.5(3)** *Outstanding tax, penalty, or interest for canceled and inactive licenses.* Any outstanding taxes, penalties, or interest must be paid before reapplying for a fuel license.

**505.5(4)** *Audit period—records—costs.* The statute of limitations on the determination of any additional tax liability shall be three years after a return is filed; therefore, all records must be kept for four years after a return is filed.

*a.* For the purpose of verifying the correctness of a return filed or for estimating the tax liability of any taxpayer, the department shall:

(1) Have the right and duty to examine or cause to be examined the books, papers, records, memoranda, or documents of a taxpayer which relate in any manner to fuel taxes.

(2) Have the authority to require, at a hearing, the attendance of the taxpayer and other witness and the production of books, papers, records, memoranda or documents.

*b.* The cost of an audit shall be at the taxpayer's expense when the records are maintained outside the state of Iowa.

**505.5(5)** *Taxpayers required to keep records.* The records required to be kept by this rule shall be preserved for a period of four years after a return is filed unless otherwise stated and shall be open for examination by the department during this period of time. A licensee shall retain invoices or other proofs of purchase which meet the requirements of subrule 505.5(6). The fact that the tax has been paid shall appear on the proof of purchase.

**505.5(6)** *Records to be kept and preserved.*

*a.* Every person required to file a quarterly report under Iowa Code section 452A.54 shall keep and preserve the following records:

(1) Fuel purchase invoices or documentation of fuel withdrawn from bulk storage.

(2) Trip sheets or other documentation of mileage activity.

*b.* Whenever an invoice is required to be kept or prepared by Iowa Code chapter 452A or these rules, the following shall be the minimal requirements which must be complied with:

(1) It must include the seller's name and address.

(2) It must include the purchaser's name and address.

(3) It must contain a vehicle serial number, fleet unit number or vehicle license number.

(4) It must include the calendar date of purchase.

(5) It must indicate the type of fuel purchased.

(6) It must indicate the quantity of fuel purchased.

(7) It must indicate the total purchase price.

(8) If the purchase is special fuel, the fact that the fuel tax is included in the purchase price must be indicated.

*c.* Whenever an invoice is required to be kept under Iowa Code chapter 452A or these rules, the original or duplicate copy must be kept. If the original or duplicate copy is lost or destroyed, a copy, certified by the seller as being a true copy of the original, shall be acceptable.

*d.* A copy of any invoice, which is required to be kept by the purchaser, must be kept by the seller for the same period of time.

*e.* Credit card invoices are acceptable if they meet all the requirements listed in paragraphs 505.5(6) "b," "c," and "d" above.

**505.5(7)** *New licensees.* When a person is issued a new license, the department may, within one year of issuance of the license, audit the records of the new licensee for a period going back two years from the date of issuance.

**505.5(8)** *Nonlicense and nonpermit holders.* All persons who bring into the state a qualified motor vehicle, upon which the Iowa tax on said fuel has not been paid, are operating within the purview of these rules as stated in Iowa Code section 452A.55. They are therefore subject to audit and must keep the same records required of a fuel licensee.

**505.5(9)** *Interstate—intrastate operators—motor vehicle special fuel holding tanks.* If a person operates one or more qualified motor vehicles under a fuel license and also operates one or more qualified motor vehicles which are not operated under the fuel license, record keeping regarding the fuel consumed from the special holding tank may be performed in either of the following ways:

- a. Operators of interstate vehicles shall be given an invoice that meets the standards set forth in Iowa Code section 452A.17, subsection 3, for each tank fill, and the vehicle operator must then log the mileage; or
- b. The licensee shall report total miles driven and total fuel used from the bulk tank, including both interstate and intrastate vehicles.

This rule is intended to implement Iowa Code sections 452A.53, 452A.55, 452A.60, 452A.62, and 452A.69.

#### **761—505.6(452A) Hearings.**

**505.6(1)** *Conduct of hearings.* Hearings are conducted in accordance with Iowa Code section 452A.69.

**505.6(2)** *Circumstances for holding hearings.*

a. When there is reasonable cause to believe that there is an evasion of fuel taxes, the department may cause a hearing to be held to determine the amount of fuel taxes due, if any. The person who is suspected of evading fuel taxes shall be sent at least ten days' notice of the hearing. The provisions of Iowa Code section 452A.64 and subrule 505.4(13), paragraph "b," shall apply.

b. If a licensee disputes the findings of an investigation or audit by the department, the licensee may request a hearing to present further evidence, information or records to support the claim. The written request for hearing shall be directed to the attention of the director of the vehicle and motor carrier services bureau within 30 days of the date of notice of audit results issued by the department.

This rule is intended to implement Iowa Code sections 452A.64 and 452A.69.

[ARC 5178C, IAB 9/9/20, effective 10/14/20]

[Filed 4/21/80, Notice 3/5/80—published 5/14/80, effective 6/18/80]

[Filed 1/23/81, Notices 11/12/80, 12/24/80—published 2/18/81, effective 3/25/81]

[Filed 12/2/81, Notice 9/30/81—published 12/23/81, effective 1/27/82]

[Filed 2/7/83, Notice 12/22/82—published 3/2/83, effective 4/6/83]

[Filed emergency 4/24/84—published 5/23/84, effective 4/24/84]

[Filed 7/6/84, Notice 5/23/84—published 8/1/84, effective 9/5/84]

[Filed 1/9/85, Notice 11/21/84—published 1/30/85, effective 3/6/85]

[Filed 2/7/86, Notice 12/18/85—published 2/26/86, effective 4/2/86]

[Filed 5/11/87, Notice 3/11/87—published 6/3/87, effective 7/8/87]

[Filed emergency 3/26/92—published 4/15/92, effective 4/29/92]

[Filed 4/8/93, Notice 3/3/93—published 4/28/93, effective 6/2/93]<sup>1</sup>

[Filed 11/7/02, Notice 10/2/02—published 11/27/02, effective 1/1/03]

[Filed 9/14/05, Notice 8/3/05—published 10/12/05, effective 11/16/05]

[Filed 12/12/07, Notice 11/7/07—published 1/2/08, effective 2/6/08]

[Filed ARC 5178C (Notice ARC 5080C, IAB 7/15/20), IAB 9/9/20, effective 10/14/20]

<sup>1</sup> Effective date of 505.2, 505.3(2) "a," 505.3(4) "b," 505.3(5) "b," 505.3(6) "c," 505.3(7) "a" and "c," 505.4(12) "b," 505.6(2) "b," June 2, 1993, delayed 70 days by the Administrative Rules Review Committee at its meeting held May 12, 1993; delay lifted by this Committee June 8, 1993, effective June 9, 1993.



CHAPTERS 506 to 509  
Reserved

CHAPTER 510  
DESIGNATED HIGHWAY SYSTEM  
[Prior to 6/3/87, Transportation Department[820]—(07,A) Ch1]  
Rescinded IAB 7/6/94, effective 6/30/94



CHAPTER 511  
SPECIAL PERMITS FOR OPERATION AND MOVEMENT OF  
VEHICLES AND LOADS OF EXCESS SIZE AND WEIGHT

[Appeared as Ch 2, Highway Commission, 1973 IDR; amended in July 1974 and January and July 1975 Supplements]

[Previously numbered as (07,E) Ch 12, transferred at the request of the department on 10/8/75]

[Prior to 6/3/87, Transportation Department[820]—(07,F) Ch 2]

**761—511.1(321E) Definitions.** As used in this chapter, unless the context otherwise requires:

“*Compacted rubbish vehicle*” means any vehicle hauling rubbish that has been mechanically compacted with a hydraulic, electric, or air-operated ram.

“*Department*” means the Iowa department of transportation.

“*Dimensions*” or “*size*” means length, width or height limits.

“*Emergency interstate permit*” means a permit issued under Iowa Code section 321E.29B.

“*Fluid milk product*” means the same as defined in Iowa Code section 321E.29B(3).

“*Indivisible load*” means any load or vehicle exceeding applicable length or weight limits which, if separated into smaller loads or vehicles, would:

1. Compromise the intended use of the vehicle, i.e., make it unable to perform the function for which it was intended;

2. Destroy the value of the load or vehicle, i.e., make it unusable for its intended purpose; or

3. Require more than eight work hours to dismantle using appropriate equipment. The applicant for an indivisible load permit has the burden of proof as to the number of work hours required to dismantle the load.

“*Overdimensional*” or “*oversize*” means the exceeding of statutory length, width or height limits.

“*Permit*” means a permit issued under Iowa Code chapter 321E for the movement of an overdimensional or overweight vehicle, combination of vehicles, or vehicle with load. The term includes any additions or supplements thereto issued by the permit-issuing authority.

“*Permit-issuing authority*” means the:

1. Department’s motor vehicle division for permits for movement on the primary road system.

2. Authority responsible for the maintenance of a nonprimary system of highways or streets for permits for movement on that system. However, the motor vehicle division may issue single-trip permits on primary road extensions in cities in conjunction with movement on the rural primary road system.

“*Primary roads*” or “*primary road system*” is defined in Iowa Code section 306.3. The primary road system includes the interstate road system.

“*Raw forest products*” means the same as defined in Iowa Code section 321E.26.

“*Rubbish*” means any unwanted or useless material that has no commercial or practical value or use and that would normally be discarded.

“*Special or emergency situation*” means one or more of the following:

1. Circumstances where the movement is necessary to cooperate with cities, counties, other state agencies or other states in response to a national or other disaster.

2. Circumstances where the movement is necessary to cooperate with national defense officials.

3. Circumstances where the movement is necessary to cooperate with public or private utilities in order to maintain their public services.

4. Circumstances where the movement is essential to ensure safety and protection of any person or property due to an event such as, but not limited to, pollution of natural resources, a potential fire or an explosion.

5. Circumstances where weather or transportation problems create an undue hardship for citizens of the state of Iowa.

6. Circumstances where the movement involves emergency-type vehicles.

7. Uncommon or extraordinary circumstances where the movement is essential to the existence of an Iowa business and the move may be accomplished without causing undue hazards to the safety of the traveling public or undue damage to private or public property.

8. Other unique circumstances that warrant the issuance of a permit as determined by the permit-issuing authority.

“*Stafford Act*” means the Robert T. Stafford Disaster Relief and Emergency Assistance Act, Public Law No. 93-288, as amended, 42 U.S.C. §5121 et seq.

“*Statutory*” when used with size or weight limits refers to those limits found in Iowa Code chapter 321.

This rule is intended to implement Iowa Code sections 321E.9, 321E.15, 321E.26, 321E.29, 321E.29B, 321E.30 and 321E.34.

[ARC 3193C, IAB 7/5/17, effective 8/9/17; ARC 4985C, IAB 3/11/20, effective 4/15/20; ARC 6061C, IAB 12/1/21, effective 1/5/22; ARC 6405C, IAB 7/13/22, effective 8/17/22; ARC 7079C, IAB 10/4/23, effective 11/8/23]

### **761—511.2(321E) Location and general information.**

**511.2(1)** Applications, forms, instructions and restrictions are available on the department's website at [www.iowadot.gov](http://www.iowadot.gov) and by mail from the Motor Vehicle Division, Iowa Department of Transportation, P.O. Box 10382, Des Moines, Iowa 50306-0382; in person at 6310 SE Convenience Blvd., Ankeny, Iowa; by telephone at (515)237-3264; or by facsimile at (515)237-3257. Permits may be obtained electronically upon making application to the motor vehicle division.

**511.2(2)** No overdimensional or overweight vehicle, combination of vehicles, or vehicle with load shall be moved on the highways of this state without permit except as provided in Iowa Code section 321.453.

**511.2(3)** Rescinded IAB 2/7/01, effective 3/14/01.

**511.2(4)** Except as provided in rule 761—511.10(321,321E) or 761—511.18(321,321E), permits may be issued only for the transporting of a single article which exceeds statutory size or weight limits or both, and which cannot reasonably be divided or reduced to statutory size and weight limits. However, permits may be issued for the transporting of property consisting of more than one article when:

- a. The statutory weight limits are not exceeded,
- b. One of the articles exceeds the statutory size limits, and
- c. The inclusion of other articles does not cause the statutory size limits to be exceeded by an additional amount.

**511.2(5)** Nothing in the permit shall be construed as waiving any load limits which have been or which might be established on any bridge or any road which is posted with embargo signs, unless specifically stated on the permit.

**511.2(6)** The state of Iowa, the department, and any other permit-issuing authority assume no responsibility for the property of the permit holder. Permit holders shall hold permit-issuing authorities harmless of any damages that may be sustained by the traveling public, adjacent property owners or the highways of this state on account of movements made under permit.

This rule is intended to implement Iowa Code sections 17A.3 and 321E.2.

[ARC 3193C, IAB 7/5/17, effective 8/9/17; ARC 4985C, IAB 3/11/20, effective 4/15/20; ARC 5428C, IAB 2/10/21, effective 3/17/21; ARC 6061C, IAB 12/1/21, effective 1/5/22; ARC 6405C, IAB 7/13/22, effective 8/17/22; ARC 7079C, IAB 10/4/23, effective 11/8/23]

### **761—511.3(321E) Movement under permit.**

**511.3(1)** During the movement of a vehicle or object under permit, the permit holder shall comply with the terms and conditions of the permit and shall take all reasonable precautions to protect and safeguard the lives and property of the traveling public and adjacent property owners.

**511.3(2)** Movement shall be made only when roads are clear of ice and snow and visibility is at least one-quarter mile. Snow removal equipment operating under permit is exempt from this restriction while snow removal operations are conducted. EXCEPTION: Nothing in this subrule shall be construed to mean that the movement of a compacted rubbish vehicle permitted under rule 761—511.12(321E) shall be subject to this restriction.

**511.3(3)** Movement shall be permitted only during the hours from one-half hour before sunrise to one-half hour after sunset unless it is established by the permit-issuing authority that the movement can be better accomplished at another period of time because of traffic volume conditions.

**511.3(4)** Except as provided in Iowa Code section 321.457, no movement shall be permitted on the holidays of Memorial Day, Independence Day and Labor Day, after 12 noon on days preceding these holidays and holiday weekends, during holiday weekends, or during special events when abnormally high traffic volumes can be expected. A holiday weekend occurs when the holiday falls on Friday, Saturday, Sunday or Monday. No movement shall be permitted until one-half hour before sunrise on the day after the holiday or holiday weekend.

**511.3(5)** Continuous moves. Vehicles and loads may travel by permit between one-half hour after sunset and one-half hour before sunrise if, in addition to the general provisions and general requirements specified by the permit, the following conditions are met.

a. Dimensions shall not exceed:

- (1) Width. 11 feet.
- (2) Height. 14 feet, 6 inches.
- (3) Length. 100 feet.
- (4) Weight. Legal axle limits.

b. Travel must be on roadways with a minimum width of 22 feet and minimum lane width of 11 feet.

c. Safety lighting shall be provided at the widest part of a load. The lamps may be placed at the outer ends of the load itself or on appurtenances which are equal in width to the widest part of the load and positioned at both the extreme front and rear of the vehicle or trailer as follows:

- (1) One lighted red lamp on each side at the rear of the load.
- (2) One lighted yellow or amber lamp on each side at the front of the load.

This rule is intended to implement Iowa Code sections 321E.2 and 321E.11.

[ARC 3193C, IAB 7/5/17, effective 8/9/17; ARC 7079C, IAB 10/4/23, effective 11/8/23]

**761—511.4(321E) Permits.** Permits issued shall be in writing or in electronic format and may be either single-trip, multitrip, annual oversize, annual oversize/overweight, annual raw forest products, annual small crane, compacted rubbish, emergency interstate, annual fluid milk products, annual all-systems oversize, or annual all-systems overweight permits.

**511.4(1) Methods of issuance.**

a. Permits for movement on the primary road system may be obtained in person, by facsimile, online, or by mail at the address in subrule 511.2(1).

b. Reserved.

**511.4(2) Forms.**

a. Applications for permits for movement on the primary road system shall be made online or in the form and manner prescribed by the department.

b. Any applications to other permit-issuing authorities made upon department forms shall be sufficient and accepted as properly made by these authorities.

c. Subject to the preceding paragraph, permit-issuing authorities may adopt, amend or modify these forms provided that the amended or modified forms adequately identify the applicant, the hauling vehicle and load, the manner and extent that the vehicle with load exceeds the statutory size and weight limits, the route, and the authorization of the issuing authority. However, the load for a multitrip permit does not have to be identified but the vehicle and load cannot exceed either the weight per axle or the total weight identified on the multitrip permit. Axle spacings cannot change.

**511.4(3) Validity.**

a. Annual oversize, annual oversize/overweight, annual raw forest products, annual small crane, compacted rubbish, annual fluid milk products, annual all-systems oversize, and annual all-systems overweight permits shall expire one year from the date of issuance.

b. A single-trip permit shall be effective for five days.

c. The validity of a multitrip permit shall not exceed 60 calendar days.

d. Emergency interstate permits issued under Iowa Code section 321E.29B shall be effective for 30 calendar days. However, the permit shall not exceed the expiration of the applicable governor's proclamation of disaster emergency issued under Iowa Code section 29C.6 in conjunction with the presidential declaration allowing interstate travel under the Stafford Act or the expiration of the declaration of major disaster under the Stafford Act, whichever expires first.

**511.4(4) Duplicate permit.** If a permit is lost or destroyed before it has expired, a duplicate permit may be issued at the discretion of the permit-issuing authority. The expiration date on the duplicate permit shall be the same as on the original permit.

This rule is intended to implement Iowa Code sections 321E.2, 321E.3, 321E.8, 321E.9 and 321E.29B.

[ARC 0136C, IAB 5/30/12, effective 7/4/12; ARC 3193C, IAB 7/5/17, effective 8/9/17; ARC 4985C, IAB 3/11/20, effective 4/15/20; ARC 5428C, IAB 2/10/21, effective 3/17/21; ARC 6061C, IAB 12/1/21, effective 1/5/22; ARC 6405C, IAB 7/13/22, effective 8/17/22; ARC 7079C, IAB 10/4/23, effective 11/8/23; ARC 7747C, IAB 4/3/24, effective 5/8/24]

**761—511.5(321,321E) Fees and charges.**

**511.5(1) Annual oversize permit.** A fee of \$50 shall be charged for each annual oversize permit issued pursuant to Iowa Code section 321E.8, payable prior to the issuance of the permit. Carriers purchasing annual oversize permits in advance of use cannot return unused permits for refunds.

**511.5(2) Special or emergency oversize permit for certain divisible loads.** A fee of \$25 may be charged for each single-trip permit issued pursuant to Iowa Code section 321E.29, payable prior to the issuance of the permit.

**511.5(3) Annual raw forest products permit.** A fee of \$175 shall be charged for each annual raw forest products permit issued pursuant to Iowa Code section 321E.26 for divisible loads of raw forest products, payable prior to the issuance of the permit.

**511.5(4) Annual oversize/overweight permit.** A fee of \$400 shall be charged for each annual oversize/overweight permit, payable prior to the issuance of the permit. Transfer of current annual oversize/overweight permit to a replacement vehicle may be allowed when the original vehicle has been damaged in an accident, junked or sold.

**511.5(5) Annual all-systems oversize permit.** A fee of \$160 shall be charged for each annual all-systems oversize permit issued pursuant to Iowa Code section 321E.8(1), payable prior to the issuance of the permit.

**511.5(6)** *Annual all-systems overweight permit.* A fee of \$500 shall be charged for each annual all-systems overweight permit issued pursuant to Iowa Code section 321E.8(2), payable prior to the issuance of the permit. Transfer of current annual all-systems overweight permit to a replacement vehicle may be allowed when the original vehicle has been damaged in an accident, junked or sold.

**511.5(7)** *Bridge-exempt permit.* A fee of \$25 shall be charged for each bridge-exempt permit issued pursuant to Iowa Code section 321E.7, payable prior to the issuance of the permit.

**511.5(8)** *Multitrip permit.* A fee of \$200 shall be charged for each multitrip permit, payable prior to the issuance of the permit.

**511.5(9)** *Raw milk permit.* A fee of \$25 shall be charged for each raw milk permit issued pursuant to Iowa Code section 321E.29A, payable prior to the issuance of the permit.

**511.5(10)** *Single-trip permit.* A fee of \$35 shall be charged for each single-trip permit, payable prior to the issuance of the permit.

**511.5(11)** *Special alternative energy multitrip permit.* A fee of \$600 shall be charged for each special alternative energy multitrip permit issued pursuant to Iowa Code section 321E.9B, payable prior to the issuance of the permit.

**511.5(12)** *Compacted rubbish permit.* A fee of \$100 shall be charged for each compacted rubbish permit, payable prior to the issuance of the permit.

**511.5(13)** *Annual fluid milk products permit.* A fee of \$400 shall be charged for each annual fluid milk products permit issued pursuant to Iowa Code section 321E.29B, payable prior to issuance of the permit.

**511.5(14)** *Annual small crane permit.* A fee of \$400 shall be charged for each annual small crane permit issued pursuant to Iowa Code section 321E.8(4), payable prior to issuance of the permit. Transfer of current annual small crane permit to a replacement vehicle may be allowed when the original vehicle has been damaged in an accident, junked or sold.

**511.5(15)** *Duplicate permit.* A fee of \$2 shall be charged for each duplicate permit, payable prior to the issuance of the permit.

**511.5(16)** *Registration fee.* A registration fee shall be charged for vehicles transporting buildings, except mobile homes and factory-built structures, on a single-trip basis. The vehicle shall be registered for the combined gross weight of the vehicle and load. The fee shall be 5 cents per ton exceeding the weight registered under Iowa Code section 321.122 per mile of travel and shall be payable prior to the issuance of the permit. Fees shall not be prorated for fractions of miles.

**511.5(17)** *Fair and reasonable costs.* Permit-issuing authorities may charge any permit applicant:

*a.* A fair and reasonable cost for the removal and replacement of natural obstructions or official signs and signals.

*b.* A fair and reasonable cost for measures necessary to avoid damage to public property including structures and bridges.

**511.5(18)** *Methods of payment.* Fees and costs required under this chapter shall be paid in the form and manner prescribed by the department.

This rule is intended to implement Iowa Code sections 321.12, 321.122, 321E.8, 321E.9, 321E.14, 321E.29, 321E.29A and 321E.30.

[ARC 3193C, IAB 7/5/17, effective 8/9/17; ARC 4985C, IAB 3/11/20, effective 4/15/20; ARC 5428C, IAB 2/10/21, effective 3/17/21; ARC 6405C, IAB 7/13/22, effective 8/17/22; ARC 7079C, IAB 10/4/23, effective 11/8/23; ARC 7747C, IAB 4/3/24, effective 5/8/24]

## **761—511.6(321E) Insurance and bonds.**

### **511.6(1)** *Insurance.*

*a.* Public liability insurance in the amounts of \$100,000 bodily injury each person, \$200,000 bodily injury each occurrence, and \$50,000 property damage with an expiration date to cover the tenure of the annual oversize, annual oversize/overweight, annual raw forest products, annual small crane, annual all-systems oversize, annual all-systems overweight, multitrip, emergency interstate, annual fluid milk products or single-trip permit shall be required. In lieu of filing with the permit-issuing authority, a copy of the current certificate of public liability insurance in these amounts shall be carried in the vehicle for which the permit has been issued. Proof of liability insurance may be either in writing or in electronic format.

*b.* Notwithstanding paragraph “a” of this subrule, a carrier may act as a self-insurer if an application for self-insurance is filed with and approved by the department.

### **511.6(2)** *Bond.*

*a.* The permit-issuing authority may require the applicant to file a bond, certified check or other assurance in an amount sufficient to cover the reasonably anticipated cost of damage or loss to private property, either real or personal,

likely to be caused by or arising out of the movement of the vehicle and load or to ensure compliance with permit provisions.

*b.* The amount in the preceding paragraph may be reduced either in whole or in part by the applicant's submission to the permit-issuing authority of written permission from an affected third party stating in substance that the third party either owns or has the right of exclusive possession and control over the affected property, does by the party's signature consent to the move and that the applicant has in hand paid or secured the payment of the anticipated cost of loss or damage to the party's property.

This rule is intended to implement Iowa Code sections 321E.8, 321E.9, 321E.13 and 321E.29B.

[ARC 3193C, IAB 7/5/17, effective 8/9/17; ARC 4985C, IAB 3/11/20, effective 4/15/20; ARC 6061C, IAB 12/1/21, effective 1/5/22; ARC 6405C, IAB 7/13/22, effective 8/17/22; ARC 7079C, IAB 10/4/23, effective 11/8/23; ARC 7747C, IAB 4/3/24, effective 5/8/24]

**761—511.7(321,321E) Annual oversize permits.** Annual oversize permits are issued for indivisible vehicles or indivisible loads for travel when the dimensions of the vehicle or load exceed statutory limits but the weight is within statutory limits. Routing is subject to embargoed bridges and roads and posted speed limits. The owner or operator shall select a route using the vertical clearance map and road construction and travel restrictions map provided by the department. Route, detour and road embargo information may be found online at [www.511ia.org](http://www.511ia.org) or the department's website for the embargo bridge maps. Annual oversize permits are issued for the following:

**511.7(1)** Vehicles with indivisible loads, including special mobile equipment, mobile homes and factory-built structures, provided the following are not exceeded:

- a. Width.* 12 feet 5 inches including appurtenances.
- b. Length.* 120 feet 0 inches overall.
- c. Height.* 13 feet 10 inches.
- d. Weight.* See rule 761—511.17(321,321E).

*e. Distance.* Movement is allowed for unlimited distance; routing through the motor vehicle division is not required.

**511.7(2)** Vehicles with indivisible loads, including special mobile equipment, mobile homes and factory-built structures, provided the following are not exceeded:

- a. Width.* 14 feet 6 inches.
- b. Length.* 120 feet 0 inches overall.
- c. Height.* 15 feet 5 inches.
- d. Weight.* See rule 761—511.17(321,321E).

*e. Distance.* Movement is restricted to 50 miles unless trip routes are obtained from the motor vehicle division or the route continues on at least four-lane roads. Trip routes are valid for five days.

**511.7(3)** Vehicles with indivisible loads, including special mobile equipment, mobile homes and factory-built structures, provided the following are not exceeded:

- a. Width.* 16 feet 0 inches.
- b. Length.* 120 feet 0 inches.
- c. Height.* 15 feet 5 inches.
- d. Weight.* See rule 761—511.17(321,321E).
- e. Distance.* Trip routes must be obtained from the motor vehicle division.

**511.7(4)** Truck trailers manufactured or assembled in the state of Iowa provided the following are met:

- a. Width.* Not to exceed 10 feet 0 inches.
- b. Length.* Overall combination length must comply with Iowa Code section 321.457.
- c. Height.* Statutory: Not to exceed 13 feet 6 inches.
- d. Weight.* See rule 761—511.17(321,321E).
- e. Roadway width.* At least 24 feet 0 inches.

*f. Limited movement.* Movement shall be solely for the purpose of delivery or transfer from the point of manufacture or assembly to another point of manufacture or assembly within the state or to a point outside the state and shall be on the most direct route necessary for the movement.

This rule is intended to implement Iowa Code sections 321.454, 321.456, 321.457, 321.463, 321E.2, 321E.3, 321E.8, 321E.10 and 321E.29A.

[ARC 3193C, IAB 7/5/17, effective 8/9/17; ARC 4985C, IAB 3/11/20, effective 4/15/20; ARC 5428C, IAB 2/10/21, effective 3/17/21; ARC 6061C, IAB 12/1/21, effective 1/5/22; ARC 6405C, IAB 7/13/22, effective 8/17/22; ARC 7079C, IAB 10/4/23, effective 11/8/23]

**761—511.8(321,321E) Annual oversize/overweight permits.** Annual oversize/overweight permits are issued for indivisible vehicles or indivisible loads for travel when either the dimensions or the weight or both the dimensions and the weight exceed statutory limits. Travel is not allowed on the interstate. However, a carrier moving under this annual

oversize/overweight permit may operate under the same restrictions as an annual oversize permit under rule 761—511.7(321,321E) when the vehicle meets the dimensions required by that rule. Routing is subject to embargoed bridges and roads and posted speed limits. Annual oversize/overweight permits are issued for the following:

**511.8(1)** Vehicles with indivisible loads, including special mobile equipment, mobile homes and factory-built structures, provided the following are not exceeded:

- a. *Width.* 13 feet 5 inches.
- b. *Length.* 120 feet 0 inches.
- c. *Height.* 15 feet 5 inches.
- d. *Weight.* See rule 761—511.17(321,321E).
- e. *Routing.* The owner or operator shall select a route using a vertical clearance map, bridge embargo map, pavement restrictions map, and construction and travel restrictions map provided by the department. Route, detour and road embargo information may be found online at [www.511ia.org](http://www.511ia.org) or the department's website for the embargo bridge maps.

**511.8(2)** Reserved.

This rule is intended to implement Iowa Code sections 321.454, 321.456, 321.457, 321.463, 321E.2, 321E.3, 321E.8 and 321E.9.

[ARC 3193C, IAB 7/5/17, effective 8/9/17; ARC 4985C, IAB 3/11/20, effective 4/15/20; ARC 5428C, IAB 2/10/21, effective 3/17/21; ARC 6061C, IAB 12/1/21, effective 1/5/22; ARC 6405C, IAB 7/13/22, effective 8/17/22; ARC 7079C, IAB 10/4/23, effective 11/8/23]

**761—511.9(321,321E) Annual all-systems oversize permits.** Annual all-systems oversize permits are issued by the motor vehicle division for indivisible vehicles or indivisible loads for travel on the primary road system and specified city streets and county roads when the dimensions of the vehicle or load exceed statutory limits but the weight is within statutory limits. Routing is subject to embargoed bridges and roads and posted speed limits. The department will provide a map of the authorized city streets and county roads. Permit holders shall consult with local officials when traveling on county roads or city streets for bridge embargo, vertical clearance, detour, and road construction information. These permits are issued for the following:

**511.9(1)** Vehicles with indivisible loads, including special mobile equipment, mobile homes and factory-built structures, provided the following are not exceeded:

- a. *Width.* 12 feet 5 inches including appurtenances.
- b. *Length.* 120 feet 0 inches overall.
- c. *Height.* 13 feet 10 inches.
- d. *Weight.* See rule 761—511.17(321,321E).
- e. *Distance.* Movement is allowed for unlimited distance; routing through the motor vehicle division and city and county jurisdictions is not required.

**511.9(2)** Vehicles with indivisible loads, including special mobile equipment, mobile homes and factory-built structures, provided the following are not exceeded:

- a. *Width.* 14 feet 6 inches.
- b. *Length.* 120 feet 0 inches overall.
- c. *Height.* 15 feet 5 inches.
- d. *Weight.* See rule 761—511.17(321,321E).
- e. *Distance.* Movement is restricted to 50 miles unless trip routes are obtained from the motor vehicle division and city and county jurisdictions or the route continues on at least four-lane roads. Trip routes are valid for five days.

**511.9(3)** Vehicles with indivisible loads, including special mobile equipment, mobile homes and factory-built structures, provided the following are not exceeded:

- a. *Width.* 16 feet 0 inches.
- b. *Length.* 120 feet 0 inches.
- c. *Height.* 15 feet 5 inches.
- d. *Weight.* See rule 761—511.17(321,321E).
- e. *Distance.* Trip routes must be obtained from the motor vehicle division and city and county jurisdictions.

**511.9(4)** Truck trailers manufactured or assembled in the state of Iowa provided the following are met:

- a. *Width.* Not to exceed 10 feet 0 inches.
- b. *Length.* Overall combination length must comply with Iowa Code section 321.457.
- c. *Height.* Statutory: Not to exceed 13 feet 6 inches.
- d. *Weight.* See rule 761—511.17(321,321E).
- e. *Roadway width.* At least 24 feet 0 inches.

*f. Limited movement.* Movement shall be solely for the purpose of delivery or transfer from the point of manufacture or assembly to another point of manufacture or assembly within the state or to a point outside the state and shall be on the most direct route necessary for the movement.

**511.9(5)** Necessary trip routes must be obtained from the appropriate city and county jurisdictions.

This rule is intended to implement Iowa Code sections 321.454, 321.456, 321.457, 321.463, 321E.2, 321E.3, 321E.8 and 321E.10.

[ARC 3193C, IAB 7/5/17, effective 8/9/17; ARC 4985C, IAB 3/11/20, effective 4/15/20; ARC 5428C, IAB 2/10/21, effective 3/17/21; ARC 6061C, IAB 12/1/21, effective 1/5/22; ARC 6405C, IAB 7/13/22, effective 8/17/22; ARC 7079C, IAB 10/4/23, effective 11/8/23]

**761—511.10(321,321E) Annual all-systems overweight permits.**

**511.10(1)** *Issuance.* Annual all-systems overweight permits are issued by the department for indivisible vehicles or indivisible or divisible loads for travel on the primary road system and specified city streets and county roads when the weight of the vehicle or load exceeds statutory limits but the dimensions are within statutory limits. Routing is subject to embargoed bridges and roads and posted speed limits. The department will provide a map of the authorized city streets and county roads. Permit holders shall consult with local officials when traveling on county roads or city streets for bridge embargo, vertical clearance, detour, and road construction information. These permits are issued for vehicles with divisible or indivisible loads provided the following are not exceeded:

*a. Width.* Statutory: 8 feet 6 inches including appurtenances.

*b. Length.* Statutory: 75 feet 0 inches overall.

*c. Height.* Statutory: 13 feet 6 inches.

*d. Weight.* See rule 761—511.17(321,321E).

*e. Distance.* Movement is allowed for unlimited distance; routing through the motor vehicle division and city and county jurisdictions is not required.

**511.10(2)** *Distribution of monthly credit.* In accordance with Iowa Code section 312.2(18), the department shall allocate the monthly credit as follows:

*a.* The department shall maintain a list of participating counties. The list shall be updated on a monthly basis as determined by the department after consultation with county officials through their representative organizations.

*b.* The monthly credit shall be divided among the participating counties as determined by the department after consultation with county officials through their representative organizations.

*c.* The funds from the monthly credit shall be distributed to each participating county based on the list of participating counties for the applicable month.

This rule is intended to implement Iowa Code sections 312.2, 321.454, 321.456, 321.457, 321.463, 321E.2, 321E.3, 321E.8 and 321E.10.

[ARC 7079C, IAB 10/4/23, effective 11/8/23]

**761—511.11(321,321E) Multitrip permits.** Multitrip permits are issued for indivisible vehicles or indivisible loads for travel when either the dimensions or the weight or both the dimensions and the weight exceed statutory limits. The permit shall be for unlimited trips along a specific route between one point of origin and one point of destination. Additional routes will require a new permit. Multitrip permits are issued for the following:

**511.11(1)** Multitrip permits may be issued for vehicles with indivisible loads, including special mobile equipment, mobile homes and factory-built structures, provided the following are not exceeded:

*a. Width.* 16 feet.

*b. Length.* 120 feet.

*c. Height.* 15 feet 5 inches.

*d. Weight.* 156,000 pounds total gross weight.

*e. Distance.* On routes specified by the permit-issuing authority.

**511.11(2)** Multitrip permits may be issued for all movements allowed under the single-trip permit provisions of rule 761—511.13(321,321E) provided the movement is within the size and weight limitations of subrule 511.10(1) 511.11(1).

**511.11(3)** The dimensions listed on the permit are considered maximums. The movement is legal as long as the vehicle and load do not exceed these dimensions and the movement meets all other requirements of Iowa Code chapter 321E and this chapter of rules.

This rule is intended to implement Iowa Code sections 321.454, 321.456, 321.457, 321.463, 321E.2, 321E.3 and 321E.9A.

[ARC 3193C, IAB 7/5/17, effective 8/9/17; ARC 7079C, IAB 10/4/23, effective 11/8/23]

**761—511.12(321E) Compacted rubbish vehicle permits.** All compacted rubbish vehicle permits issued by the department shall be subject to the following:

**511.12(1)** Permits issued shall be in writing or in an electronic format, shall be carried in the vehicle for which the permit has been issued and shall be available for inspection by any peace officer or authorized agent of any permit-granting authority.

**511.12(2)** Movements by permit shall be allowed day and night, seven days a week including holidays.

**511.12(3)** Vehicles traveling under permit shall be registered for the gross weight or combined gross weight of the vehicle and load.

**511.12(4)** Vehicles under permit must be in compliance with posted bridge and road embargoes and speed limits.

**511.12(5)** Maximum axle weight allowed on the interstate system shall be 20,000 pounds on a single axle and 34,000 pounds on a tandem axle.

This rule is intended to implement Iowa Code section 321E.30.

[ARC 3193C, IAB 7/5/17, effective 8/9/17; ARC 7079C, IAB 10/4/23, effective 11/8/23]

**761—511.13(321,321E) Single-trip permits.** Single-trip permits are issued for indivisible vehicles or indivisible loads for travel when either the dimensions or the weight or both the dimensions and the weight exceed statutory limits. The permit shall be for a specific route between an origin and destination. Single-trip permits are issued for the following:

**511.13(1)** Vehicles with indivisible loads, including special mobile equipment, mobile homes and factory-built structures, provided the following are not exceeded:

*a. Width.* Limited to the maximum physical limitations and clearances of the roadway and infrastructure along the intended route of travel.

*b. Length.* Limited to the maximum physical limitations and clearances of the roadway along the intended route of travel.

*c. Height.* Limited only to the height of underpasses, bridges, power lines, and other established height restrictions. The carrier shall be required to contact affected public utilities when the height of the vehicle with load exceeds 16 feet 0 inches. At the discretion of the permit-issuing authority, a written verification may be required from the affected utility.

*d. Weight.* See rule 761—511.17(321,321E).

*e. Distance.* Limited at the discretion of the permit-issuing authority. The following factors shall be considered:

Road conditions; road width; traffic volume; weather conditions; and roadside obstructions, including bridges, signs and overhead obstructions.

**511.13(2)** Reserved.

This rule is intended to implement Iowa Code sections 321.454, 321.456, 321.457, 321.463, 321E.2, 321E.3 and 321E.9.

[ARC 3193C, IAB 7/5/17, effective 8/9/17; ARC 4985C, IAB 3/11/20, effective 4/15/20; ARC 5428C, IAB 2/10/21, effective 3/17/21; ARC 6061C, IAB 12/1/21, effective 1/5/22; ARC 6405C, IAB 7/13/22, effective 8/17/22; ARC 7079C, IAB 10/4/23, effective 11/8/23]

**761—511.14(321,321E) Annual raw forest products permits.** Annual raw forest products permits are issued for vehicles transporting divisible loads of raw forest products when the weight exceeds statutory limits. Travel is not allowed on the interstate. The owner or operator shall select a route using the vertical clearance map, bridge embargo map, pavement restrictions map, and construction and travel restrictions map provided by the department. The owner or operator must contact the appropriate local authority for route approval to use this permit on county roads or city streets. Detour and road embargo information may be found online at: [www.511ia.org](http://www.511ia.org). Routing is subject to embargoed bridges and roads and posted speed limits. Annual raw forest products permits are issued for the following:

**511.14(1)** Vehicles with divisible loads of raw forest products provided the following are not exceeded:

*a. Width.* Statutory: 8 feet 6 inches.

*b. Length.* Limited to the maximum dimensions in Iowa Code section 321.457.

*c. Height.* Statutory: 13 feet 6 inches.

*d. Weight.* See rule 761—511.17(321,321E).

*e. Distance.* Unlimited.

**511.14(2)** Reserved.

This rule is intended to implement Iowa Code sections 321.463, 321E.2, 321E.3 and 321E.26.

[ARC 4985C, IAB 3/11/20, effective 4/15/20; ARC 6061C, IAB 12/1/21, effective 1/5/22; ARC 6405C, IAB 7/13/22, effective 8/17/22; ARC 7079C, IAB 10/4/23, effective 11/8/23]

**761—511.15(29C,321,321E) Emergency interstate permit.** Emergency interstate permits are issued for vehicles transporting divisible loads of relief supplies when the weight exceeds statutory limits. Routing is subject to embargoed bridges and roads and posted speed limits. The owner or operator shall select a route using the vertical clearance map and road construction and travel restrictions map provided by the department. Route, detour, and road embargo information may be found online at [www.511ia.org](http://www.511ia.org) or the department's website for the embargo bridge maps. The owner or operator must contact the appropriate local authority for route approval to determine if additional permits are necessary for county roads or city streets. Emergency interstate permits are issued for the following:

**511.15(1)** Vehicles with divisible loads of relief supplies, which may exceed the weight limits established under Iowa Code section 321.463 on the interstate highway system, provided the following are not exceeded:

- a. *Width.* Statutory: 8 feet 6 inches including appurtenances.
- b. *Length.* Limited to the maximum dimensions in Iowa Code section 321.457.
- c. *Height.* Statutory: 13 feet 6 inches.
- d. *Weight.* See rule 761—511.17(321,321E).
- e. *Distance.* Movement is allowed for unlimited distance on the interstate for 30 days not to exceed the expiration of the applicable governor's proclamation issued in conjunction with the applicable declaration under the Stafford Act, or expiration of the applicable declaration under the Stafford Act, whichever expires sooner. In the event that more than one proclamation issued under Iowa Code section 29C.6 is in effect, only the proclamation issued in conjunction with the same event that caused the major disaster declaration under the Stafford Act shall govern the expiration date. Separate permits may be required for roads other than the interstate unless the governor, under the authority in Iowa Code section 29C.6, suspends applicable permitting provisions under proclamation for the same event.

**511.15(2)** Reserved.

This rule is intended to implement Iowa Code sections 29C.6, 321.457, 321.463 and 321E.29B.

[ARC 6061C, IAB 12/1/21, effective 1/5/22; ARC 6405C, IAB 7/13/22, effective 8/17/22; ARC 7079C, IAB 10/4/23, effective 11/8/23]

**761—511.16(321,321E) Annual fluid milk products permits.** Annual fluid milk products permits are issued for indivisible loads of fluid milk products for travel when the weight of the vehicle or load exceeds statutory limits. Routing is subject to embargoed bridges and roads and posted speed limits. The owner or operator shall select a route using the vertical clearance map and road construction and travel restrictions map provided by the department. Route, detour, road embargo and bridge embargo for fluid milk products information may be found online at [www.511ia.org](http://www.511ia.org) and the department's website.

**511.16(1)** The following shall not be exceeded:

- a. *Width.* Statutory: 8 feet 6 inches including appurtenances.
- b. *Length.* Statutory: 75 feet 0 inches overall.
- c. *Height.* Statutory: 13 feet 6 inches.
- d. *Weight.* See rule 761—511.17(321,321E).
- e. *Distance.* Movement is allowed for unlimited distance on the primary road system, including the interstate, provided the vehicle is transporting fluid milk products to or from a milk plant, receiving station, or transfer station; routing through the motor vehicle division is not required.

**511.16(2)** Reserved.

This rule is intended to implement Iowa Code sections 321.454, 321.456, 321.457, 321.463, 321E.2, 321E.3, 321E.8, 321E.10 and 321E.29A.

[ARC 6405C, IAB 7/13/22, effective 8/17/22; ARC 7079C, IAB 10/4/23, effective 11/8/23]

**761—511.17(321,321E) Maximum axle weights and maximum gross weights for vehicles and loads moved under permit.**

**511.17(1)** *Annual oversize, annual all-systems oversize, and annual all-systems overweight permits.*

- a. For movement under an annual oversize or annual all-systems oversize permit, the axle weight and combined gross weight shall not exceed the limits found in Iowa Code section 321.463(3).
- b. For movement under an all-systems overweight permit, the axle weight shall not exceed the limits found in Iowa Code sections 321.463(3) and 321E.8. The combined gross weight shall not exceed the gross weight authorized under Iowa Code section 321E.8(2).
- c. See subrule 511.16(7) 511.17(8) for exceptions for special mobile equipment.

**511.17(2)** *Annual oversize/overweight permits or annual raw forest products permits.*

- a. For movement under an annual oversize/overweight permit or an annual raw forest products permit, the gross weight on any axle shall not exceed 20,000 pounds, with a maximum of 156,000 pounds total gross weight.

*b.* See subrule 511.17(8) for exceptions for special mobile equipment.

**511.17(3) *Multitrip permits.***

*a.* For movement under a multitrip permit, the gross weight on any axle shall not exceed 20,000 pounds with a maximum of 156,000 pounds total gross weight.

*b.* See subrule 511.17(8) for exceptions for special mobile equipment.

**511.17(4) *Single-trip permits.***

*a.* For movement under a single-trip permit, the gross weight on any axle shall not exceed 20,000 pounds unless authorized under Iowa Code section 321E.9(2).

*b.* If the combined gross weight exceeds 100,000 pounds, a single-trip permit may be issued for the movement only if the permit-issuing authority determines that it would not cause undue damage to the road and is in the best interest of the public.

*c.* Cranes may have a maximum of 24,000 pounds per axle for movement under a single-trip permit. Routes must be reviewed by the permit-issuing authority prior to issuance.

*d.* See subrule 511.17(8) for exceptions for special mobile equipment.

**511.17(5) *Emergency interstate permits.***

*a.* For movement under this permit, the gross weight on any axle shall not exceed 20,000 pounds with a maximum of 90,000 pounds total gross weight.

*b.* The maximum weight on any single axle shall not exceed by more than 12.5 percent the maximum axle weight limit in the nonprimary highway maximum gross weight table in Iowa Code section 321.463(6)“*b*” and must comply with posted limits on roads and bridges.

**511.17(6) *Annual fluid milk products permits.*** For movement under an annual fluid milk products permit, the gross weight on any axle shall not exceed 20,000 pounds with a maximum of 96,000 pounds total gross weight.

**511.17(7) *Annual small crane permit.*** For movement under an annual small crane permit, the gross weight on any axle shall not exceed 24,000 pounds with a maximum of 80,000 pounds total gross weight.

**511.17(8) *Special mobile equipment.*** Special mobile equipment may have a gross weight of 36,000 pounds on any single axle equipped with minimum size 26.5-inch by 25-inch flotation pneumatic tires and a maximum gross weight of 20,000 pounds on any single axle equipped with minimum size 18-inch by 25-inch flotation pneumatic tires, provided that the total gross weight of the vehicle or a combination of vehicles does not exceed a maximum of 80,000 pounds for movement under an annual oversize or all-systems oversize permit and 126,000 pounds for movement under a single-trip, multitrip or annual oversize/overweight permit.

For tire sizes and weights allowed between the maximum and minimum indicated, the following formula shall apply: Axle weight = 20,000 pounds + (tire width - 18) × 1,882 pounds.

**511.17(9) *Permitted tandem axle weights.***

*a.* Vehicles operating under an annual oversize permit, annual oversize/overweight permit, annual raw forest products permit, single-trip permit, or multitrip permit may have a gross weight not to exceed 46,000 pounds on a single-tandem axle of the truck tractor and a gross weight not to exceed 46,000 pounds on a single-tandem axle of the trailer or semitrailer if each axle of each tandem group has at least four tires.

*b.* The maximum weight of any single axle within a permitted tandem axle group shall be 24,000 pounds.

*c.* A permitted tandem axle shall not be a part of a larger group of axles whose centers are greater than 96 inches apart.

This rule is intended to implement Iowa Code sections 321.463, 321E.7, 321E.8, 321E.9, 321E.9A, 321E.26, 321E.29B and 321E.32.

[ARC 3193C, IAB 7/5/17, effective 8/9/17; ARC 4345C, IAB 3/13/19, effective 4/17/19; ARC 4985C, IAB 3/11/20, effective 4/15/20; ARC 6061C, IAB 12/1/21, effective 1/5/22; ARC 6405C, IAB 7/13/22, effective 8/17/22; ARC 7079C, IAB 10/4/23, effective 11/8/23; ARC 7747C, IAB 4/3/24, effective 5/8/24]

**761—511.18(321,321E) Movement of vehicles with divisible loads exceeding statutory size or weight limits.**

**511.18(1)** Vehicles with divisible loads exceeding statutory size or weight limits may be moved under a single-trip permit if the permit-issuing authority determines that a special or emergency situation warrants its issuance.

**511.18(2)** At the discretion of the permit-issuing authority, the combined gross weight may exceed the statutory weight, but the axle weights shall be subject to rule 761—511.17(321,321E).

**511.18(3)** Movement shall be subject to the routes established by the permit-issuing authority.

This rule is intended to implement Iowa Code sections 321.463 and 321E.29.

[ARC 3193C, IAB 7/5/17, effective 8/9/17; ARC 4985C, IAB 3/11/20, effective 4/15/20; ARC 5428C, IAB 2/10/21, effective 3/17/21; ARC 6061C, IAB 12/1/21, effective 1/5/22; ARC 6405C, IAB 7/13/22, effective 8/17/22; ARC 7079C, IAB 10/4/23, effective 11/8/23]

**761—511.19(321E) Towing units.** The towing unit shall be a truck or truck tractor with dual wheels and with a gross vehicle weight rating of at least 10,000 pounds when towing mobile homes or loads exceeding 10,000 pounds.

This rule is intended to implement Iowa Code section 321.457.

[ARC 3193C, IAB 7/5/17, effective 8/9/17; ARC 4985C, IAB 3/11/20, effective 4/15/20; ARC 6061C, IAB 12/1/21, effective 1/5/22; ARC 6405C, IAB 7/13/22, effective 8/17/22; ARC 7079C, IAB 10/4/23, effective 11/8/23]

**761—511.20(321E) Escorting.**

**511.20(1) Escort qualification.** An escort shall be a person aged 18 or over who possesses a valid driver’s license which allows driving unaccompanied and who carries proof of public liability insurance in the amounts of \$100,000/\$200,000/\$50,000.

**511.20(2) Escorting responsibilities.**

a. The escorting vehicle shall be a mid-size automobile or motor truck with sufficient mobility to be able to assist in an emergency and designed to afford clear and unobstructed vision both front and rear. The escorting vehicle shall not be used to tow a trailer while performing escorting duties. In questionable cases the permit-issuing authority shall determine if a vehicle meets these conditions.

b. The escorting vehicle shall have a flashing or strobe amber light that is visible for at least 500 feet and provides 360° warning. While escorting a permit load, the light shall be mounted on top of the escort vehicle and shall be burning. Additional escort vehicle markings may be approved or required by the permit-issuing authority.

c. An 18-inch by 18-inch red or orange fluorescent flag shall be mounted on each corner of the front bumper of the escort vehicle.

d. The escort shall remain a distance of approximately 300 feet in front or to the rear of the load. However, when traveling within the corporate limits of a city, the escort shall maintain a reasonable and proper distance consistent with existing traffic conditions.

e. A separate escort shall be provided for each load hauled under escort.

f. All traffic laws and provisions of the oversize permit for the load shall be obeyed.

g. The escort shall not assume responsibility for stopping traffic. An on-duty peace officer, as defined in Iowa Code section 321.1, shall be contacted to provide any traffic control needed.

h. Immediately prior to an escorting trip, the escort shall determine that the escorting vehicle is in a safe operational condition and that the dimensions of the vehicle and load are in compliance with the permit issued.

i. Escort fees charged by state and local authorities shall not exceed \$250 per day per escort vehicle.

j. A pole used for measuring vertical clearances shall be mounted on the front escort vehicle. The escort shall be required to measure all vertical clearances whenever the height of the permitted vehicle exceeds 14 feet 6 inches up to and including 20 feet.

**511.20(3) Requirements for escorts, flags, signs and lights.** The following chart explains the minimum escort and warning devices required for vehicles operating under permit.

Minimum Warning Devices and Escort Requirements  
For Vehicles Operating Under Permit

|                                       | Flags/Signs  | Lights       | Escorts                  |                          |
|---------------------------------------|--------------|--------------|--------------------------|--------------------------|
|                                       |              |              | 4-Lane                   | 2-Lane                   |
| <b>Length</b>                         |              |              |                          |                          |
| 75'1" up to and including 85'         | yes          | not required | not required             | not required             |
| Over 85' up to and including 120'     | yes          | yes          | not required             | not required             |
| Over 120'                             | yes          | not required | rear                     | rear                     |
| <b>Projections</b>                    |              |              |                          |                          |
| Front: over 25'                       | not required | yes          | not required             | not required             |
| Rear: over 4' up to and including 10' | flags only   | not required | not required             | not required             |
| Rear: over 10'                        | flags only   | yes          | not required             | not required             |
| <b>Height</b>                         |              |              |                          |                          |
| Over 14'6" up to and including 20'    | yes          | not required | front with a height pole | front with a height pole |
| <b>Weight</b>                         |              |              |                          |                          |
| Over 80,000 lbs.                      | not required | not required | not required             | not required             |

| Width                                |     |              |              |              |
|--------------------------------------|-----|--------------|--------------|--------------|
| Over 8'6" up to 12'0"                | yes | not required | not required | not required |
| Over 12'0" up to and including 14'6" | yes | not required | rear *       | front *      |
| Over 14'6" up to and including 16'6" | yes | not required | rear *       | front        |
| Over 16'6" up to and including 18'   | yes | not required | rear         | front        |

\*In lieu of an escort, a carrier can display an amber light or strobe light on the power unit and on the rear extremity of the vehicle or load.

yes = required

Definitions:

Flags - Red or orange fluorescent flags at least 18" square must be mounted as follows: one flag at each front corner of the towing unit and one flag at each rear corner of the load. In addition, there must be a flag at any additional protrusion in the width of the load.

Signs - A sign reading "Oversize Load" must be used. The sign must be at least 18" high by 7' long with a minimum of 10" black letters, with a 1/2" stroke, on a yellow background, and mounted on the front bumper and on the rear of the load. The rear sign for mobile homes and factory-built structures must be mounted at least 7' above the highway surface, measuring from the bottom of the sign.

Lights - A flashing or strobe amber light that is visible for at least 500 feet and provides 360° warning must be mounted on the towing unit and be visible from front and rear. More than one light may be necessary.

The permit-issuing authority may require additional escorts when deemed necessary. The signs or warning devices must be removed or covered when the vehicle is within legal dimensions.

This rule is intended to implement Iowa Code sections 321E.8, 321E.14, 321E.24 and 321E.34.

[ARC 3193C, IAB 7/5/17, effective 8/9/17; ARC 4985C, IAB 3/11/20, effective 4/15/20; ARC 6061C, IAB 12/1/21, effective 1/5/22; ARC 6405C, IAB 7/13/22, effective 8/17/22; ARC 7079C, IAB 10/4/23, effective 11/8/23]

**761—511.21(321,321E) Permit violations.** Permit violations are to be reported to the permit-issuing authority by the arresting officer and the permit holder. If a permit holder is found to have willfully violated permit provisions, the motor vehicle division may, after notice and hearing, suspend, modify or revoke the permit privileges of the permit holder consistent with Iowa Code section 321E.20. If the permit that is suspended, modified, or revoked is an emergency interstate permit that is issued for a fleet operating under the permit holder's interstate or intrastate motor carrier number, the department may issue emergency interstate permits to individual vehicles operating under the interstate or intrastate motor carrier number.

This rule is intended to implement Iowa Code sections 321.492, 321E.16, 321E.20 and 321E.29B.

[ARC 3193C, IAB 7/5/17, effective 8/9/17; ARC 4985C, IAB 3/11/20, effective 4/15/20; ARC 6061C, IAB 12/1/21, effective 1/5/22; ARC 6405C, IAB 7/13/22, effective 8/17/22; ARC 7079C, IAB 10/4/23, effective 11/8/23]

**761—511.22(321) Movement of combination vehicles on economic export corridors.**

**511.22(1) Designation of economic export corridors.**

a. The department may in its discretion establish economic export corridors for the transportation of goods or products manufactured in Iowa to or through the state of South Dakota and for the return of unladen semitrailers or unladen full trailers used for the transportation of those goods or products. An economic export corridor shall not include any segment of the interstate system or any part of the national network of highways identified pursuant to 23 CFR Part 658. However, if appropriate, the department may petition the Federal Highway Administration to remove a road or road segment from the national network of highways for the purpose of including it in an economic export corridor.

b. The department may initiate designation of economic export corridors, or a request for economic export corridor designation may be submitted to the department by an interested party. If a proposed economic export corridor includes any roads or road segments that are under the jurisdiction of a city or a county, a resolution from all relevant local jurisdictions must be submitted to the department indicating their support for economic export corridor designation. The resolution must include a description of the proposed economic export corridor under local jurisdiction.

c. The department shall exercise due regard for the safety of the traveling public and the protection of the highway surfaces and structures when establishing an economic export corridor. Factors to be considered include ability of the proposed economic export corridor to safely accommodate combinations of vehicles described in subrule

511.21(2) 511.22(2), taking into account physical configurations and restrictions and traffic demands and capacity, as well as connection to markets that will benefit from the established economic export corridor.

d. The department will post established economic export corridors on the department's website.

**511.22(2) *Combination vehicles that may be operated on an economic export corridor.***

a. In addition to combinations of vehicles lawful for operation on roads or road segments not designated as an economic export corridor, the following combinations of vehicles may be operated on an economic export corridor designated under subrule 511.22(1) if the combinations of vehicles meet the requirements in paragraph 511.22(2) "b":

(1) A truck tractor-semitrailer-semitrailer converted to a full trailer by use of a dolly equipped with a fifth wheel which is considered a part of the trailer for all purposes, and not a separate unit; or

(2) A truck tractor-semitrailer-full trailer; or

(3) A truck tractor-semitrailer-semitrailer combination, where the semitrailers are connected by a rigid frame extension including a fifth wheel connection point attached to the rear frame of the first semitrailer.

b. The combination of vehicles shall meet all of the following requirements:

(1) The length of the combination of vehicles, excluding the length of the truck tractor, shall not exceed 81½ feet.

(2) The length of either semitrailer or full trailer shall not exceed 45 feet.

(3) The weight of the second semitrailer or full trailer shall not exceed the weight of the first semitrailer by more than 3,000 pounds.

(4) The gross weight of the combination of vehicles shall not exceed 80,000 pounds and the combination of vehicles shall not exceed the gross axle weight limits of Iowa Code section 321.463(2).

(5) The load on each semitrailer or full trailer in the combination shall be an indivisible load. For the purpose of issuing permits for height or width under Iowa Code chapter 321E, the combination of vehicles shall be considered an indivisible load so long as the load on each semitrailer or full trailer in the combination remains an indivisible load.

c. The length of the frame extension shall not be included when determining the overall length of the first semitrailer in a truck tractor-semitrailer-semitrailer combination in which the semitrailers are connected by a rigid frame extension including a fifth wheel connection point attached to the rear frame of the first semitrailer.

d. For purposes of this subrule, "full trailer" means as defined in 49 CFR Section 390.5.

This rule is intended to implement Iowa Code section 321.457(2) "n."

[ARC 3193C, IAB 7/5/17, effective 8/9/17; ARC 4985C, IAB 3/11/20, effective 4/15/20; ARC 6061C, IAB 12/1/21, effective 1/5/22; ARC 6405C, IAB 7/13/22, effective 8/17/22; ARC 7079C, IAB 10/4/23, effective 11/8/23]

[Filed February 5, 1969; amended May 1, 1969, October 14, 1969,

April 30, 1970, October 15, 1971, April 15, 1974, December 4, 1974,

May 14, 1975; transferred to Department of Transportation, July 1, 1975]

[Filed 5/26/76, Notice 4/5/76—published 6/14/76, effective 7/19/76]

[Filed 9/16/77, Notice 7/13/77—published 10/5/77, effective 11/9/77]

[Filed 9/8/78, Notice 7/26/78—published 10/4/78, effective 11/8/78]

[Filed emergency 6/21/79—published 7/11/79, effective 6/21/79]

[Filed emergency 9/20/79—published 10/17/79, effective 9/20/79]

[Filed 1/28/80, Notice 12/12/79—published 2/20/80, effective 3/26/80]

[Filed emergency 2/14/80 after Notice 12/12/79—published 3/5/80, effective 3/26/80]

[Filed 6/2/81, Notice 4/15/81—published 6/24/81, effective 7/29/81]

[Filed 12/2/81, Notice 9/30/81—published 12/23/81, effective 1/27/82]

[Filed 12/16/82, Notice 10/27/82—published 1/5/83, effective 2/9/83]

[Filed emergency 3/31/83—published 4/27/83, effective 3/31/83]

[Filed 12/11/85, Notice 10/23/85—published 1/1/86, effective 2/5/86]

[Filed 5/11/87, Notice 3/11/87—published 6/3/87, effective 7/8/87]

[Filed 5/13/87, Notice 3/25/87—published 6/3/87, effective 7/8/87]

[Filed emergency 3/26/92—published 4/15/92, effective 4/29/92]

[Filed 4/8/93, Notice 3/3/93—published 4/28/93, effective 6/2/93]<sup>1</sup>

[Filed emergency 7/8/94—published 8/3/94, effective 7/8/94]

[Filed 9/8/94, Notice 8/3/94—published 9/28/94, effective 11/2/94]

[Filed 3/5/97, Notice 1/15/97—published 3/26/97, effective 4/30/97]

[Filed emergency 6/26/97—published 7/16/97, effective 7/1/97]

[Filed 8/27/97, Notice 7/16/97—published 9/24/97, effective 10/29/97]

[Filed 1/16/01, Notice 11/29/00—published 2/7/01, effective 3/14/01]

[Filed 12/19/01, Notice 11/14/01—published 1/23/02, effective 2/27/02]

[Filed 9/11/02, Notice 7/10/02—published 10/2/02, effective 11/6/02]

[Filed 9/14/05, Notice 8/3/05—published 10/12/05, effective 11/16/05]

[Filed 12/13/06, Notice 11/8/06—published 1/3/07, effective 2/7/07]

[Filed 12/12/07, Notice 11/7/07—published 1/2/08, effective 2/6/08]

[Filed ARC 0136C (Notice ARC 0068C, IAB 4/4/12), IAB 5/30/12, effective 7/4/12]

[Filed ARC 3193C (Notice ARC 3045C, IAB 5/10/17), IAB 7/5/17, effective 8/9/17]

[Filed ARC 4345C (Notice ARC 4231C, IAB 1/16/19), IAB 3/13/19, effective 4/17/19]

[Filed ARC 4985C (Notice ARC 4869C, IAB 1/15/20), IAB 3/11/20, effective 4/15/20]

[Filed ARC 5428C (Notice ARC 5292C, IAB 12/2/20), IAB 2/10/21, effective 3/17/21]

[Filed ARC 6061C (Notice ARC 5923C, IAB 9/22/21), IAB 12/1/21, effective 1/5/22]

[Filed ARC 6405C (Notice ARC 6311C, IAB 5/4/22), IAB 7/13/22, effective 8/17/22]

[Filed ARC 7079C (Notice ARC 7046C, IAB 7/12/23), IAB 10/4/23, effective 11/8/23]

[Filed ARC 7747C (Notice ARC 7491C, IAB 1/10/24), IAB 4/3/24, effective 5/8/24]

<sup>1</sup> Effective date of 511.2(1), 511.4(1)“a,” 511.4(2)“a” and “b,” 511.5(1), 511.5(6)“b”(3), 511.7, 511.8, 511.9(1) to 511.9(5), 511.14(2)“g” and “i,” 511.14(3)“e,” delayed 70 days by the Administrative Rules Review Committee at its meeting held May 12, 1993; delay lifted by this Committee June 8, 1993, effective June 9, 1993.

CHAPTER 512

Reserved

CHAPTER 513

COMPACTED RUBBISH VEHICLE PERMITS

[Prior to 6/3/87, Transportation Department[820]—(07,F) Ch 6]

Rescinded **ARC 3193C**, IAB 7/5/17, effective 8/9/17

CHAPTERS 514 to 519

Reserved

CHAPTER 520

REGULATIONS APPLICABLE TO CARRIERS

[Prior to 6/3/87, Transportation Department[820]—(07,F) Ch 8]

Transferred to 661—Chapter 22, IAC Supplement 7/26/23

CHAPTERS 521 and 522

Reserved

CHAPTER 523

TRUCK OPERATORS AND CONTRACT CARRIERS

[Transferred from IDR 1973, Commerce Commission, Ch 3, 7/1/75]

[Prior to 6/3/87, Transportation Department[820]—(07,F)Ch 3]

Rescinded IAB 8/11/99, effective 9/15/99



CHAPTER 524  
FOR-HIRE INTRASTATE MOTOR CARRIER AUTHORITY

**761—524.1(325A) Purpose and applicability.**

**524.1(1)** This chapter establishes requirements concerning for-hire intrastate motor carriers as authorized by Iowa Code chapter 325A.

**524.1(2)** This chapter applies to motor carriers of household goods, bulk liquid commodities, all other property, and passengers being transported for hire on any highway of this state other than a transportation network company or transportation network company driver as both are defined in Iowa Code section 321N.1 and provided for in 761—Chapter 540.

[ARC 4346C, IAB 3/13/19, effective 4/17/19]

**761—524.2(325A) General information.**

**524.2(1)** *Information and location.* Applications, forms and information on motor carrier permits and motor carrier certificates are available by mail from the Vehicle and Motor Carrier Services Bureau, Iowa Department of Transportation, P.O. Box 10382, Des Moines, Iowa 50306-0382; in person at 6310 SE Convenience Blvd., Ankeny, Iowa; by telephone at (515)237-3268; by facsimile at (515)237-3225; or by email at [omcs@iowadot.us](mailto:omcs@iowadot.us).

**524.2(2)** *Waiver of rules.* In accordance with 761—Chapter 11, the director of transportation may, in response to a petition, waive provisions of this chapter. A waiver shall not be granted unless the director finds that special or emergency circumstances exist.

“*Special or emergency circumstances*” means one or more of the following:

1. Circumstances where the movement is necessary to cooperate with cities, counties, other state agencies or other states in response to a national or other disaster.
2. Circumstances where the movement is necessary to cooperate with national defense officials.
3. Circumstances where the movement is necessary to cooperate with public or private utilities in order to maintain their public services.
4. Circumstances where the movement is essential to ensure safety and protection of any person or property due to events such as, but not limited to, pollution of natural resources, a potential fire or an explosion.
5. Circumstances where weather or transportation problems create an undue hardship for citizens of the state of Iowa.
6. Circumstances where movement involves emergency-type vehicles.
7. Uncommon or extraordinary circumstances where the movement is essential to the existence of an Iowa business and the move may be accomplished without causing undue hazards to the safety of the traveling public or undue damage to private or public property.

**524.2(3)** *Complaints.* Complaints against motor carriers pertaining to the provisions of this chapter shall be submitted in writing to the vehicle and motor carrier services bureau.

[ARC 4346C, IAB 3/13/19, effective 4/17/19; ARC 5047C, IAB 6/3/20, effective 7/8/20]

**761—524.3(325A) Applications and supporting documents.**

**524.3(1)** *Application.* An application for a motor carrier permit or motor carrier certificate shall be made to the vehicle and motor carrier services bureau in the form and manner prescribed by the department.

**524.3(2)** *Application fee.* An application for a motor carrier permit or motor carrier certificate shall be accompanied by the statutory application fee. This fee shall be paid by credit card or by cash, check or money order made payable to the Iowa Department of Transportation.

**524.3(3)** *Supporting documents.* An application for a motor carrier permit or motor carrier certificate must be accompanied by the following supporting documentation in the form and manner prescribed by the department:

- a. Proof of insurance.
- b. Safety self-certification. (See rule 761—524.9(325A).)
- c. A U.S. DOT number if required by the Federal Motor Carrier Safety Administration.
- d. Financial statement, only for motor carriers of bulk liquid commodities (nondairy) and regular-route passengers. (See rule 761—524.10(325A).)
- e. Tariff, only for motor carriers of household goods.
- f. All applicable documents identified in 761—subrule 380.7(2) and any other documentation, if required by the department, necessary to assess the operational capabilities of any driverless-capable vehicles the motor carrier intends to operate, including for the purpose of determining whether to impose operational restrictions as authorized under rule 761—400.21(321).

[ARC 4346C, IAB 3/13/19, effective 4/17/19; ARC 5047C, IAB 6/3/20, effective 7/8/20; ARC 5893C, IAB 9/8/21, effective 10/13/21]

**761—524.4(325A) Issuance of motor carrier permit or motor carrier certificate.** When all requirements are met, the department shall issue the motor carrier permit or certificate. The motor carrier shall make a copy of the permit or certificate and carry it in each motor vehicle at all times. The copy may be in either a physical or an electronic format as prescribed by the department. The permit or certificate shall be available for display to any peace officer upon request.

[ARC 4346C, IAB 3/13/19, effective 4/17/19; ARC 5047C, IAB 6/3/20, effective 7/8/20]

**761—524.5(325A) Duplicate motor carrier permit or motor carrier certificate.** Written requests for a duplicate motor carrier permit or motor carrier certificate shall be sent to the vehicle and motor carrier services bureau. Requests shall include the carrier name and the carrier permit number, certificate number, or U.S. DOT number. Any motor carrier in good standing shall be issued a duplicate document upon payment of the required fee.

[ARC 4346C, IAB 3/13/19, effective 4/17/19; ARC 5047C, IAB 6/3/20, effective 7/8/20]

**761—524.6(325A) Amendment to a motor carrier permit or motor carrier certificate.**

**524.6(1) Update to a motor carrier permit.** To change the commodities being transported under a permit, an updated application must be submitted to the vehicle and motor carrier services bureau. The updated application shall include the permit number and the required fee for a duplicate permit. Transporting of commodities not listed on the permit shall not commence until a new permit or temporary permit has been issued and is carried in the vehicle.

**524.6(2) Change of name or address for a motor carrier permit or certificate.** To change the name or address, an updated application shall be sent to the vehicle and motor carrier services bureau within 30 days after the change. The updated application shall include the permit or certificate number, old name or address, new name or address, and the required fee.

[ARC 4346C, IAB 3/13/19, effective 4/17/19; ARC 5047C, IAB 6/3/20, effective 7/8/20]

**761—524.7(325A) Insurance—suspension.**

**524.7(1) Insurance.** Each motor carrier shall at all times maintain on file with the department the effective certificate(s) of insurance or a surety bond on a form prescribed by the department.

a. The insurance or the surety bond shall be written for a period of one year or more.

b. The department shall be given written notice 30 days prior to the cancellation of the insurance or the surety bond.

c. Prior to July 1, 2021, the certificate of insurance may be submitted electronically in a format approved by the department. An insurance carrier that submits the certificate of insurance under this rule shall implement electronic submission of such certificate no later than July 1, 2021. As of July 1, 2021, no paper submissions of such certificates shall be accepted, and all certificates of insurance shall be submitted electronically in a format approved by the department.

**524.7(2) Self-insurance.** In lieu of maintaining the above insurance, intrastate carriers that also operate interstate and have been approved by a federal agency to self-insure may apply to the department to self-insure by submitting a written request to the vehicle and motor carrier services bureau. The written request shall include a copy of the federal agency's approval. The department shall allow self-insurance as long as a federal agency has approved the carrier to self-insure and the motor carrier provides the department with copies of any information required by that federal agency. The department must be notified immediately by the motor carrier if there is any change in the status of the self-insurance for interstate operation.

**524.7(3) Suspension for no insurance.** If a motor carrier fails to maintain the required insurance on file with the department, the department shall suspend the motor carrier's permit or certificate in accordance with Iowa Code chapter 325A and rule 761—524.17(325A). The suspension shall remain in effect until the requirements are met and a reinstatement fee is paid. A motor carrier shall not continue operation without proper insurance.

[ARC 4346C, IAB 3/13/19, effective 4/17/19; ARC 4803C, IAB 12/4/19, effective 1/8/20; ARC 5047C, IAB 6/3/20, effective 7/8/20]

**761—524.8(325A) Self-insurance for motor carriers of passengers.**

**524.8(1) Applications for self-insurance.** A motor carrier of passengers with more than 25 motor vehicles may request self-insurance by submitting a written request to the vehicle and motor carrier services bureau. The written request shall include a copy of the most recent audited financial statement and a vehicle list.

**524.8(2) Review by the department.** The department may request additional information. The department shall deny the request to self-insure or suspend existing approval if the motor carrier fails to meet the self-insurance standard. Approval of self-insurance is continuous. However, the motor carrier shall annually file audited financial

statements with the vehicle and motor carrier services bureau within 60 days after the end of the motor carrier's fiscal year.

**524.8(3) Cancellation of self-insurance approval.** The department may cancel approval of self-insurance on reasonable grounds. Reasonable grounds include, but are not limited to, the following: failure to pay a final judgment within 30 days or failure to file an annual, audited financial statement. The department shall give five days' notice to the motor carrier prior to any hearing to cancel approval of self-insurance.

[ARC 4346C, IAB 3/13/19, effective 4/17/19; ARC 5047C, IAB 6/3/20, effective 7/8/20]

**761—524.9(325A) Safety self-certification.** All motor carriers shall follow the safety regulations as stated in 661—Chapter 22 concerning operation, maintenance and inspection of vehicles used in the business. Motor carriers shall submit on a form prescribed by the department a self-certification stating knowledge, understanding and willingness to follow these safety regulations.

[Editorial change: IAC Supplement 7/26/23]

**761—524.10(325A) Financial statement.** An application by a motor carrier of bulk liquid commodities (nondairy) or regular-route passengers must include a statement signed by an authorized agent of a lending institution or a certified public accountant attesting to the financial capability of that carrier. At a minimum, the certification shall be based on meeting the following ratios:

Current Ratio: Minimum of 1.2:1

Current Assets

Current Liabilities = \_\_\_\_\_

Projected Operating Ratio: Maximum of 95

1. New Operation

(Use 5-Year Projection)  $\frac{\text{Operating Expenses}}{\text{Operating Revenue}} \times 100 =$  \_\_\_\_\_

2. Existing Operation  $\frac{\text{Operating Expenses}}{\text{Operating Revenue}}$

(Use 1-Year Projection)

Working Capital Ratio: Minimum 12 days Capital

Current Assets Less Current Liabilities

Average Daily Operating Expenses = \_\_\_\_\_

**761—524.11(325A) Safety education seminar.**

**524.11(1) Requirement.** Motor carriers of bulk liquid commodities (nondairy) and passengers shall attend an approved safety education seminar within six months of issuance of the permit or certificate except as provided in subrule 524.11(4). The individuals in attendance shall be the persons responsible for the safety records and driver training. Failure to attend an approved safety education seminar within the time provided shall result in suspension of the motor carrier permit or certificate.

**524.11(2) Availability.** The department shall provide an approved safety education seminar periodically. Information on the seminar schedule is available by mail from the Vehicle and Motor Carrier Services Bureau, Iowa Department of Transportation, P.O. Box 10382, Des Moines, Iowa 50306-0382; in person at 6310 SE Convenience Blvd., Ankeny, Iowa; by telephone at (515)237-3268; or by email at [omcs@iowadot.us](mailto:omcs@iowadot.us).

**524.11(3) Third-party safety education seminar approval.** The motor vehicle division shall approve the course curriculum before approving individuals outside the department to conduct safety education seminars. The course curriculum shall be submitted for approval to the motor vehicle division. At a minimum, the safety course curriculum shall include the following information:

a. Commercial driver's license regulations.

b. A general overview of the U.S. DOT's motor carrier safety regulations and hazardous materials regulations which are adopted annually by the department.

c. Iowa Code sections 321.449 and 321.450 and all associated administrative rules.

d. Iowa Code section 321.463 and all associated administrative rules.

e. Out-of-service criteria.

f. A general overview of the U.S. DOT's Emergency Response Guide Book.

**524.11(4) Exemption.** Passenger carriers with vehicles not meeting the definition of a commercial vehicle as defined in Iowa Code section 321.1 are exempt from attending the safety education seminar and paying the seminar fee. A motor carrier certificate issued for such a carrier contains the statement: "limited to noncommercial vehicles only." If a motor carrier wishes to start operating vehicles that meet the definition of a commercial motor vehicle, the motor carrier must update its authority with the vehicle and motor carrier services bureau. A motor carrier must pay

the seminar fee and attend the seminar within six months of updating the certificate. A new motor carrier certificate removing the limitation would then be issued.

[ARC 0136C, IAB 5/30/12, effective 7/4/12; ARC 4346C, IAB 3/13/19, effective 4/17/19; ARC 5047C, IAB 6/3/20, effective 7/8/20; Editorial change: IAC Supplement 7/26/23]

**761—524.12(325A) Marking of motor vehicles.** Transferred to 661—22.9(325A), IAC Supplement 7/26/23.

**761—524.13(325A) Bills of lading or freight receipts.** Transferred to 661—22.10(325A), IAC Supplement 7/26/23.

**761—524.14(325A) Lease of a vehicle.**

**524.14(1) Lease defined.** “Lease,” for the purpose of these rules, means a written document providing for the exclusive possession, control and responsibility over the operation of a vehicle by the lessee for a specific period of time as if the lessee were the owner. A copy of the lease must be carried in the leased vehicle at all times. No motor carrier may have more than one lease covering a specific vehicle in effect at a given time.

**524.14(2) Lease of a vehicle to a shipper or a receiver.** No motor carrier shall lease a vehicle with or without a driver to a shipper or a receiver.

**524.14(3) Marking of a motor vehicle.** Each lessee shall properly identify each motor vehicle during the period of the lease as specified in rule 661—22.9(325A).

**524.14(4) Lease requirements.** Any lease of a vehicle by any motor carrier except under the following conditions is prohibited:

a. Every lease must be in writing and signed by the parties or their regular employees or agents duly authorized to act for them.

b. Every lease shall specify the time that the lease begins and the time or circumstances on which it ends.

[Editorial change: IAC Supplement 7/26/23]

**761—524.15(325A) Tariffs.**

**524.15(1) Requirements.** All motor carriers of household goods shall maintain on file with the vehicle and motor carrier services bureau a tariff stating the rates and charges that apply for the services performed under the permit.

**524.15(2) Printing.** All tariffs and amendments or supplements must be in book, pamphlet or loose-leaf form. They must be plainly printed or reproduced. No alteration in writing or erasure shall be made in any tariff or supplement.

**524.15(3) Filing date.** All changes to tariffs and supplements must be filed with the vehicle and motor carrier services bureau at least seven days prior to the effective date. Tariffs or supplements issued in connection with applications for motor carriers of household goods may become effective on the date the permits are issued.

**524.15(4) Copy to department.** To file a tariff with the vehicle and motor carrier services bureau, motor carriers of household goods or their agents shall submit a transmittal letter listing all the enclosed tariffs and include one copy of each tariff, supplement or revised page.

**524.15(5) Title page.** The title page of every tariff and supplement shall include the following:

a. Each tariff shall be numbered in the upper right-hand corner, beginning with number 1. The number shall be shown as follows: Ia. DOT No. ....

When a tariff is issued canceling a tariff previously filed, the Ia. DOT number that has been canceled must be shown in the right-hand corner under the Ia. DOT number of the new tariff.

b. Supplements or changes to a tariff shall be numbered beginning with number 1, and this information shall be shown in the upper right-hand corner along with the number of any previous supplements canceled or changed by the supplement.

c. The name of each motor carrier of household goods must be the same as it appears on the permit. If the motor carrier of household goods is not a corporation and uses a trade name, the name of the individual or partners must precede the trade name.

d. Each tariff shall include a brief description of the territory or points from which and to which the tariff applies.

e. Each tariff shall contain the issue and effective dates.

f. Each tariff shall include the name, title and street address of the motor carrier of household goods or the agent by whom the tariff is issued.

**524.15(6) Contents of tariff.** Each tariff shall include the following:

a. A table of contents that is arranged alphabetically.

b. A complete index of all commodities including the page number. However, no index or table of contents is needed in tariffs of less than five pages or if the rates are alphabetically arranged by commodities.

c. An explanation of all abbreviations, symbols and reference marks used.

d. All rates in the tariff explicitly stated in cents or in dollars and cents per one hundred pounds, per mile, per hour, per ton or two thousand pounds, per truck load (of stated amount) or other definable measure. Where rates are stated in amounts per package or bundle, definite specifications of the packages or bundles must be shown and ambiguous terms, rates, descriptions or plans for determining charges shall not be accepted.

**524.15(7) *Duplication of rates.*** Motor carriers of household goods or their agents shall not publish duplicate or conflicting rates.

**524.15(8) *Tariff changes.*** All rates and charges which have been filed with the vehicle and motor carrier services bureau must be allowed to become effective and remain in effect for a period of at least seven days before being changed, canceled or withdrawn. All tariffs, supplements and revised pages shall indicate changes from the previous tariff. Changes may be indicated by providing a summary or by use of the following symbols:

(R) to denote reductions

(A) to denote increases

(C) to denote changes, the result of which is neither an increase nor a reduction.

**524.15(9) *Posting regulations.*** Each motor carrier of household goods must post and file at its principal place of business all of its tariffs and supplements. All tariffs must be kept available for public inspection.

**524.15(10) *Application for special permission.*** Motor carriers of household goods and agents when making application for permission to establish rates, charges, or rules of the tariff on less than the statutory seven days' notice shall use the form prescribed by the department or other form containing all of the required information.

**524.15(11) *Powers of attorney.***

a. Whenever a motor carrier of household goods desires to give authority to an agent or to another motor carrier of household goods to issue and file tariffs and supplements in its stead, a power of attorney shall be provided to the department.

b. The original power of attorney shall be filed with the vehicle and motor carrier services bureau and a copy sent to the agent or motor carrier of household goods on whose behalf the document was issued.

c. Whenever a motor carrier of household goods desires to cancel the authority granted an agent or another motor carrier of household goods by power of attorney, this may be done by a letter addressed to the department revoking the authority on 60 days' notice. For good cause, the department may authorize less than 60 days' notice. Copies of the notice must also be mailed to all interested parties by the motor carrier.

**524.15(12) *Nonconforming tariffs.*** The vehicle and motor carrier services bureau shall review tariffs that do not conform with subrules 524.15(1) to 524.15(11) to determine if the tariffs contain the necessary information and are acceptable. Tariffs that are unacceptable shall be returned with an explanation.

[ARC 4346C, IAB 3/13/19, effective 4/17/19; ARC 5047C, IAB 6/3/20, effective 7/8/20]

**761—524.16(325A) Transfer of motor carrier regular-route passenger certificate or motor carrier permit for household goods.** Rescinded IAB 5/30/12, effective 7/4/12.

**761—524.17(325A) Suspension, revocation or reinstatement.** The department may suspend or revoke a motor carrier permit or certificate for a violation of Iowa Code chapter 325A or this chapter. The suspension or revocation shall continue until the motor carrier is no longer in violation and the reinstatement fee is paid. A new permit or certificate shall be issued upon reinstatement.

**761—524.18(325A) Hearings.** A person whose application for a motor carrier permit or certificate has been denied for a reason other than noncompliance with insurance requirements or whose motor carrier permit or certificate has been suspended or revoked for a reason other than noncompliance with insurance requirements may contest the decision in accordance with Iowa Code chapter 17A and 761—Chapter 13. The request for a hearing shall be submitted in writing to the director of the vehicle and motor carrier services bureau. The request shall include, as applicable, the motor carrier's name, permit or certificate number, complete address and telephone number. The request must be submitted within 20 days after the date of the notice of suspension, revocation or denial.

[ARC 4346C, IAB 3/13/19, effective 4/17/19; ARC 5047C, IAB 6/3/20, effective 7/8/20]

These rules are intended to implement Iowa Code sections 321.515 and 321.519 and chapter 325A.

[Filed 7/14/99, Notice 5/19/99—published 8/11/99, effective 9/15/99]

[Filed 3/7/01, Notice 1/10/01—published 4/4/01, effective 5/9/01]

[Filed 5/8/02, Notice 3/20/02—published 5/29/02, effective 7/3/02]

[Filed 9/14/05, Notice 8/3/05—published 10/12/05, effective 11/16/05]

[Filed 12/12/07, Notice 11/7/07—published 1/2/08, effective 2/6/08]

[Filed ARC 0136C (Notice ARC 0068C, IAB 4/4/12), IAB 5/30/12, effective 7/4/12]  
[Filed ARC 4346C (Notice ARC 4233C, IAB 1/16/19), IAB 3/13/19, effective 4/17/19]  
[Filed ARC 4803C (Notice ARC 4681C, IAB 10/9/19), IAB 12/4/19, effective 1/8/20]  
[Filed ARC 5047C (Notice ARC 4994C, IAB 3/25/20), IAB 6/3/20, effective 7/8/20]  
[Filed ARC 5893C (Notice ARC 5621C, IAB 5/19/21), IAB 9/8/21, effective 10/13/21]  
[Editorial change: IAC Supplement 7/26/23]

CHAPTER 525  
MOTOR CARRIERS AND CHARTER CARRIERS  
[Prior to 6/3/87, Transportation Department [820]—(07F)Ch 4]  
Rescinded IAB 8/11/99, effective 9/15/99

CHAPTERS 526 and 527  
Reserved

CHAPTER 528  
LIQUID TRANSPORT CARRIERS  
[Prior to 6/3/87, Transportation Department[820]—(07,F)Ch 13]  
Rescinded IAB 8/11/99, effective 9/15/99



CHAPTER 529  
FOR-HIRE INTERSTATE MOTOR CARRIER AUTHORITY  
[Prior to 6/3/87, Transportation Department[820]—(07,F)Ch 5]

**761—529.1(327B) Motor carrier regulations.** The Iowa department of transportation adopts the Code of Federal Regulations, 49 CFR Parts 365-368 and 370-379, dated October 1, 2023 for regulating interstate for-hire carriers.

Copies of this publication are available from the state law library or at [www.fmcsa.dot.gov](http://www.fmcsa.dot.gov).

[ARC 7901B, IAB 7/1/09, effective 8/5/09; ARC 8837B, IAB 6/16/10, effective 7/21/10; ARC 0136C, IAB 5/30/12, effective 7/4/12; ARC 2986C, IAB 3/15/17, effective 4/19/17; ARC 3840C, IAB 6/6/18, effective 7/11/18; ARC 4401C, IAB 4/10/19, effective 5/15/19; ARC 5018C, IAB 4/8/20, effective 5/13/20; ARC 5547C, IAB 4/7/21, effective 5/12/21; ARC 6307C, IAB 5/4/22, effective 6/8/22; ARC 6970C, IAB 4/5/23, effective 5/10/23; ARC 8055C, IAB 6/12/24, effective 7/17/24]

**761—529.2(327B) Registering interstate authority in Iowa.** Registration for interstate exempt and nonexempt authority shall be either mailed to the Office of Vehicle and Motor Carrier Services, Iowa Department of Transportation, P.O. Box 10382, Des Moines, Iowa 50306-0382; delivered in person to 6310 SE Convenience Blvd., Ankeny, Iowa; or sent by facsimile to (515)237-3257.

[ARC 3840C, IAB 6/6/18, effective 7/11/18]

**761—529.3(327B) Waiver of rules.** In accordance with 761—Chapter 11, the director of transportation may, in response to a petition, waive provisions of this chapter. A waiver shall not be granted unless the director finds that special or emergency circumstances exist.

“*Special or emergency circumstances*” means one or more of the following:

1. Circumstances where the movement is necessary to cooperate with cities, counties, other state agencies or other states in response to a national or other disaster.
2. Circumstances where the movement is necessary to cooperate with national defense officials.
3. Circumstances where the movement is necessary to cooperate with public or private utilities in order to maintain their public services.
4. Circumstances where the movement is essential to ensure safety and protection of any person or property due to events such as, but not limited to, pollution of natural resources, a potential fire or explosion.
5. Circumstances where weather or transportation problems create an undue hardship for citizens of the state of Iowa.
6. Circumstances where movement involves emergency-type vehicles.
7. Uncommon or extraordinary circumstances where the movement is essential to the existence of an Iowa business and the move may be accomplished without causing undue hazard to the safety of the traveling public or undue damage to private or public property.

These rules are intended to implement Iowa Code section 307.27 and chapter 327B.

[Filed 7/15/75]

[Filed 10/17/80, Notice 8/20/80—published 11/12/80, effective 12/17/80]

[Filed emergency 7/18/85—published 8/14/85, effective 7/19/85]

[Filed 5/11/87, Notice 3/11/87—published 6/3/87, effective 7/8/87]

[Filed emergency 3/26/92—published 4/15/92, effective 4/29/92]

[Filed 7/14/99, Notice 5/19/99—published 8/11/99, effective 9/15/99]

[Filed 5/10/00, Notice 4/5/00—published 5/31/00, effective 7/5/00]

[Filed 3/7/01, Notice 1/10/01—published 4/4/01, effective 5/9/01]

[Filed 12/19/01, Notice 11/14/01—published 1/23/02, effective 2/27/02]

[Filed 3/13/02, Notice 2/6/02—published 4/3/02, effective 5/8/02]

[Filed 3/26/03, Notice 2/5/03—published 4/16/03, effective 5/21/03]

[Filed 4/21/04, Notice 3/17/04—published 5/12/04, effective 6/16/04]

[Filed 4/15/05, Notice 2/16/05—published 5/11/05, effective 6/15/05]

[Filed 9/14/05, Notice 8/3/05—published 10/12/05, effective 11/16/05]

[Filed 4/19/06, Notice 3/15/06—published 5/10/06, effective 6/14/06]

[Filed 3/21/07, Notice 2/14/07—published 4/11/07, effective 5/16/07]

[Filed 12/12/07, Notice 11/7/07—published 1/2/08, effective 2/6/08]

[Filed 5/14/08, Notice 4/9/08—published 6/4/08, effective 7/9/08]

[Filed ARC 7901B (Notice ARC 7716B, IAB 4/22/09), IAB 7/1/09, effective 8/5/09]

[Filed ARC 8837B (Notice ARC 8668B, IAB 4/7/10), IAB 6/16/10, effective 7/21/10]

[Filed ARC 0136C (Notice ARC 0068C, IAB 4/4/12), IAB 5/30/12, effective 7/4/12]  
[Filed ARC 2986C (Notice ARC 2878C, IAB 1/4/17), IAB 3/15/17, effective 4/19/17]  
[Filed ARC 3840C (Notice ARC 3700C, IAB 3/28/18), IAB 6/6/18, effective 7/11/18]  
[Filed ARC 4401C (Notice ARC 4256C, IAB 1/30/19), IAB 4/10/19, effective 5/15/19]  
[Filed ARC 5018C (Notice ARC 4895C, IAB 2/12/20), IAB 4/8/20, effective 5/13/20]  
[Filed ARC 5547C (Notice ARC 5411C, IAB 2/10/21), IAB 4/7/21, effective 5/12/21]  
[Filed ARC 6307C (Notice ARC 6207C, IAB 2/23/22), IAB 5/4/22, effective 6/8/22]  
[Filed ARC 6970C (Notice ARC 6822C, IAB 1/11/23), IAB 4/5/23, effective 5/10/23]  
[Filed ARC 8055C (Notice ARC 7745C, IAB 4/3/24), IAB 6/12/24, effective 7/17/24]

CHAPTERS 530 to 539  
Reserved



CHAPTER 540  
TRANSPORTATION NETWORK COMPANIES

**761—540.1(321N) Purpose and applicability.** This chapter implements the permitting and regulation requirements of Iowa Code chapter 321N, and applies to transportation network companies and transportation network company drivers.

[ARC 2987C, IAB 3/15/17, effective 4/19/17]

**761—540.2(321N) Definitions.** The definitions in Iowa Code section 321N.1 are hereby made part of and fully incorporated in this chapter.

[ARC 2987C, IAB 3/15/17, effective 4/19/17]

**761—540.3(321N) General information.**

**540.3(1) Information and location.** Applications, forms, electronic or otherwise, and information regarding transportation network company permits are available by mail from the Motor Vehicle Division, Iowa Department of Transportation, P.O. Box 10382, Des Moines, Iowa 50306-0382; in person at 6310 SE Convenience Blvd., Ankeny, Iowa; by telephone at (515)237-3156; by email at [central.vehicle@iowadot.us](mailto:central.vehicle@iowadot.us); or on the department's website at [www.iowadot.gov](http://www.iowadot.gov).

**540.3(2) Complaints.** Complaints against transportation network companies pertaining to the provisions of Iowa Code chapter 321N and this chapter that are within the regulation and jurisdiction of the department shall be submitted in writing to the motor vehicle division via the methods listed in subrule 540.3(1).

[ARC 2987C, IAB 3/15/17, effective 4/19/17; Editorial change: IAC Supplement 8/11/21; ARC 6491C, IAB 9/7/22, effective 10/12/22]

**761—540.4(321N) Application for transportation network company permit and supporting documents.**

**540.4(1) Application.** An application for a transportation network company permit shall be made to the motor vehicle division in the form and manner prescribed by the department. The form shall require all of the following:

- a. The transportation network company's full legal name and tax identification number.
- b. The address of the transportation network company's principal place of business.
- c. If incorporated or otherwise organized, the transportation network company's state of incorporation or organization.
- d. The name, address, telephone number and email address of the person submitting the application on behalf of the transportation network company.
- e. A statement confirming the transportation network company's agreement to comply with all applicable requirements of Iowa Code chapter 321N and this chapter, signed by the transportation network company's authorized representative.
- f. The name and address of the transportation network company's agent for service of process in the state of Iowa.
- g. The name by which the transportation network company will do business in the state of Iowa, if different from the transportation network company's full legal name.
- h. A description of the transportation network company's digital network and the means or manner by which it may be accessed by the transportation network company's drivers and riders. This paragraph is not intended to and shall not be construed as requiring the disclosure of information proprietary to the transportation network company.
- i. The name, address, telephone number and email address of the person through whom the department may coordinate examination of the transportation network company's records as required by Iowa Code section 321N.2(5).
- j. Such other information as may be required by the department.

**540.4(2) Application fee.** An application for a transportation network company permit shall be accompanied by the fee required by Iowa Code section 321N.2. The fee shall be made payable to the Iowa Department of Transportation in the form and manner prescribed by the department.

**540.4(3) Supporting documents.** An application for a transportation network company permit shall be accompanied by the following:

- a. Proof of compliance with the financial responsibility requirements of Iowa Code section 321N.4. Proof of compliance shall be submitted by providing a valid certificate of coverage from an insurer governed by Iowa Code chapter 515, or by a surplus lines insurer governed by Iowa Code chapter 515I. The certificate of coverage shall demonstrate coverage in the amounts and circumstances required by Iowa Code section 321N.4, and shall certify that if insurance maintained by a transportation network company driver under Iowa Code chapter 321N lapses or does not provide coverage in the amounts or types required by Iowa Code section 321N.4, subsection 2 or 3, the insurance certified in the certificate of coverage shall provide coverage in the amounts and types required by Iowa Code section

321N.4, subsection 2 or 3, beginning with the first dollar of the claim, and the insurer providing such coverage shall defend the claim. The certificate of coverage shall also certify that the coverage therein is not dependent on the insurer of a transportation network company driver's personal vehicle first denying a claim, and does not require the insurer of a personal automobile insurance policy to first deny a claim to trigger coverage and defense under the coverage certified.

*b.* Proof that the transportation network company has established a zero tolerance policy for the use of drugs and alcohol as provided in Iowa Code section 321N.3(5). The transportation network company shall provide a written copy of the applicable policy and an explanation of the manner or means by which the policy is made known to transportation network company drivers and the manner or means by which the policy is enforced.

*c.* Proof that the transportation network company has adopted and is enforcing nondiscrimination and accessibility policies. As used herein, "nondiscrimination policy" means a policy that prohibits discrimination against transportation network company riders on the basis of race, age, disability, religion, color, sex, or national origin. "Accessibility policy" means a policy that prohibits discrimination against and assures equal opportunity and access to transportation network company riders who are persons with disabilities under the Americans with Disabilities Act of 1990 (ADA) as amended by the ADA Amendments Act of 2008 (P.L. 110-325) codified at 42 U.S.C. 12101 et. seq. The transportation network company shall provide a written copy of the applicable policy and an explanation of the manner or means by which the policy is made known to transportation network company drivers and the manner or means by which the policy is enforced.

*d.* Proof that the transportation network company has established record retention guidelines that comply with the requirements of Iowa Code section 321N.2(2). The transportation network company shall provide a written copy of the applicable policy and an explanation of the manner or means by which the policy is made known to the designated records retention officer or responsible staff and the manner or means by which the policy is enforced.

*e.* Proof that the transportation network company has established a means for informing persons seeking approval to serve as transportation network company drivers of their notification obligations under Iowa Code section 321N.3(2). The transportation network company shall provide a copy of the disclosure form used by the transportation network company to inform such persons of the notification obligations under Iowa Code section 321N.3(2) and an explanation of the manner or means by which the disclosure form is made known to and signed by such persons.

*f.* Proof that the transportation network company has established a means for making the automobile insurance disclosures required by Iowa Code section 321N.5 to persons serving as transportation network company drivers. The transportation network company shall provide a copy of the written disclosure used by the transportation network company and an explanation of the manner or means by which the written disclosure is made known to transportation network company drivers.

*g.* Proof that the transportation network company has established a means for making the driver and vehicle disclosures required by Iowa Code section 321N.7 to transportation network company riders. The transportation network company shall provide an explanation of the manner or means by which the disclosure is made known to transportation network company riders.

*h.* Proof that the transportation network company has established a means for transmitting an electronic receipt to transportation network company riders as required by Iowa Code section 321N.8. The transportation network company shall include a sample, representative receipt and an explanation of the manner or means by which the receipt is delivered and the time frame within which the receipt is delivered.

*i.* If incorporated or organized, a current copy of the transportation network company's certificate of good standing from the transportation network company's state of incorporation or organization.

*j.* All applicable documents identified in 761—subrule 380.7(2) and any other documentation, if required by the department, necessary to assess the operational capabilities of any driverless-capable vehicles the transportation network company intends to operate, including for the purpose of determining whether to impose operational restrictions as authorized under rule 761—400.21(321).

*k.* Other such documents as requested by the department.

[ARC 2987C, IAB 3/15/17, effective 4/19/17; ARC 3688C, IAB 3/14/18, effective 4/18/18; Editorial change: IAC Supplement 8/11/21; ARC 5893C, IAB 9/8/21, effective 10/13/21; ARC 6491C, IAB 9/7/22, effective 10/12/22]

**761—540.5(321N) Issuance of permit.** A transportation network company shall not operate or conduct business in the state of Iowa without a valid permit issued under this chapter. Upon submission of a completed application package as set forth in rule 761—540.4(321N), the department shall process the package and shall inform the transportation network company of the package's status no later than 30 days after the department receives the package. Application package statuses for the purpose of this rule are as follows: "in process," "granted," and "denied." If the department informs a transportation network company that the application is "in process," then the

department shall also inform the transportation network company of the reason for the status. If the department determines that the transportation network company is in compliance with the provisions of Iowa Code chapter 321N and this chapter, the department shall issue a permit to the transportation network company. A permit, when issued, shall be valid for one year. The department may deny issuance of the permit if the department determines, and evidence demonstrates, that the transportation network company is not in compliance or is not able to comply with the provisions of Iowa Code chapter 321N or this chapter.

[ARC 2987C, IAB 3/15/17, effective 4/19/17]

**761—540.6(321N) Amendment to transportation network company permit.** If during the period the permit is valid any information required and presented in the application under paragraph 540.4(1) “a,” “b,” “c,” “f,” “g” or “i” changes, the transportation network company shall notify the motor vehicle division of the change in writing within 30 days after the change. Notification shall include the permit number and a recitation of the information that has changed and that should be updated in the department’s records. Submission of amended information is not a request for a new permit or for permit approval and shall not extend the period the permit is valid. Upon determination that the information submitted is complete and correct, the department shall update its records and issue an amended permit, if the department determines it is necessary.

[ARC 2987C, IAB 3/15/17, effective 4/19/17; ARC 6491C, IAB 9/7/22, effective 10/12/22]

**761—540.7(321N) Suspension.** If the department determines that the transportation network company has violated Iowa Code chapter 321N or this chapter and the violation is more than an isolated event and remains uncorrected, the department shall issue to the transportation network company a written notice of the violation. The written notice shall specify the violation and shall advise the transportation network company that failure to remedy the violation and to comply with the applicable requirements within 30 days shall result in the issuance of a written notice of suspension of the permit and the privilege to operate or conduct business as a transportation network company in the state of Iowa. If the transportation network company fails to remedy the violation within 30 days, the department shall issue to the transportation network company a written notice of suspension of the permit and the privilege to operate or conduct business as a transportation network company in the state of Iowa, which shall be effective 30 days after service of the written notice of suspension. Once effective, the suspension shall remain in effect until the transportation network company demonstrates to the department that it is in compliance with the applicable requirements or the permit is revoked or expires, whichever occurs first.

[ARC 2987C, IAB 3/15/17, effective 4/19/17]

**761—540.8(321N) Revocation.** If the department determines that the transportation network company is in continued noncompliance with Iowa Code chapter 321N or this chapter, the department shall revoke the transportation network company’s permit and the privilege to operate or conduct business as a transportation network company in the state of Iowa. Notice of revocation shall be in writing, shall specify the continued noncompliance, and shall be effective 30 days after service of the written notice of revocation. The period of revocation shall be for at least 90 days, and shall continue thereafter until the following criteria are satisfied: (1) The transportation network company submits a new application, application fee, and supporting documents under rule 761—540.4(321N), and (2) the department determines a new permit should be issued, pursuant to rule 761—540.5(321N). As used in this rule, “continued noncompliance” means a violation of Iowa Code chapter 321N or this chapter for which a notice of suspension has become effective and has remained in effect for a period of at least 180 days.

[ARC 2987C, IAB 3/15/17, effective 4/19/17]

#### **761—540.9(321N) Appeal.**

**540.9(1)** A transportation network company whose permit has been suspended, revoked, or denied may request an informal settlement or a contested case proceeding as provided in 761—Chapter 13 to contest said action.

**540.9(2)** The request shall be submitted in writing to the director of the motor vehicle division at the address indicated in subrule 540.3(1), and may be submitted electronically by facsimile, email or other means prescribed by the department. To be timely, the request must be submitted within 20 days of service of the notice of suspension, revocation or denial. Failure to contest denial of a permit application does not preclude the transportation network company from submitting a new application for a permit at any time after the denial.

**540.9(3)** When the department receives a properly submitted, timely request for an informal settlement or contested case proceeding or an appeal of a presiding officer’s proposed decision regarding a suspension or revocation, the department shall stay the suspension or revocation pending resolution of the informal resolution, contested case, or appeal.

[ARC 2987C, IAB 3/15/17, effective 4/19/17; Editorial change: IAC Supplement 8/11/21; ARC 6491C, IAB 9/7/22, effective 10/12/22]

**761—540.10(321N) Renewal.**

**540.10(1)** A transportation network company that has been issued and holds a valid permit may renew the permit by submitting, at minimum, the following: (1) the application, (2) the application fee and (3) the supporting documents as set forth in rule 761—540.4(321N). The application for renewal must be submitted no more than 60 days before the expiration date of the existing permit and no fewer than 30 days before the expiration date of the existing permit.

**540.10(2)** Pursuant to Iowa Code section 17A.18(2), when a transportation network company has made a timely and sufficient application for the renewal of a valid permit, the existing permit does not expire until the application has been finally determined by the department, and, in case the application is denied or the terms of the new permit are limited, until the last day for seeking judicial review of the department's order or a later date fixed by order of the department or the reviewing court.

**540.10(3)** If the application for renewal is submitted fewer than 30 days before the expiration date of the existing permit, then the application shall be considered a new application and Iowa Code section 17A.18(2) shall not apply. If a transportation network company does not file a renewal application pursuant to this rule, then the original application shall expire on the expiration date set forth on the original permit.

**540.10(4)** If a transportation network company initiates an appeal, informal settlement, or contested case proceeding pursuant to rule 761—540.9(321N) and the original application expires pursuant to the expiration date of the application, then the transportation network company shall be required to submit a renewal application pursuant to subrule 540.10(1) if the transportation network company intends to hold a valid permit under this chapter once the appeal, informal settlement, or contested case proceeding has been finally determined.

[ARC 2987C, IAB 3/15/17, effective 4/19/17]

**761—540.11(321N) Record review.**

**540.11(1)** When the department examines the records of a transportation network company as authorized under Iowa Code section 321N.2(5), the department may request the transportation network company to provide a list of all prearranged rides for a seven-day period or all transportation network company drivers in Iowa for a specific date. The transportation network company shall provide the required information to the department within 30 days of the request.

**540.11(2)** For the records provided under subrule 540.11(1), the department may identify a random sample of rides or drivers, or rides and drivers, for review for the specified period. The transportation network company shall provide additional information for each driver and each rider for each ride as requested by the department.

*a.* Additional information requested for the transportation network company driver shall include the following:

(1) A copy of the driver's license for the transportation network company driver.

(2) A copy of the driver's state-issued vehicle registration, including year, make, model, VIN and license plate number.

(3) A copy of proof of the driver's financial liability coverage. The copy shall include the driver's insurance company name, address, and policy number. In addition, a copy of proof of financial liability coverage maintained to comply with Iowa Code sections 321N.4(2) and 321N.4(3) that includes coverages and limits may be satisfied by any of the following:

1. Insurance maintained by the transportation network company driver.

2. Insurance maintained by the transportation network company.

3. A combination of numbered paragraphs 1 and 2.

(4) A copy of or a verification that all necessary disclosures were supplied to the driver by the transportation network company, including the lienholder, vehicle owner, insurance and motor vehicle equipment requirements.

(5) A copy of all complaints received by the transportation network company from any rider who received a ride from the driver. This includes, but is not limited to, complaints related to drug or alcohol use, vehicle safety, motor vehicle equipment safety, driver behavior, driver ability or operation of the vehicle.

(6) A summary or other documentation that shows how the transportation network company resolved any complaint from a rider.

(7) Documentation or verification of the background and sex offender registry check on the driver.

*b.* Additional information for each transportation network company rider shall include the electronic ride receipt provided to the rider.

**540.11(3)** Notwithstanding any provision of subrule 540.11(1) to the contrary, the department and the transportation network company may agree to an alternative process or format for the transportation network company to provide the requested records if the records otherwise include the information required in subrule 540.11(2).

**540.11(4)** Records submitted by the transportation network company to the department pursuant to this rule shall maintain the same status, including confidentiality and disclosure requirements as provided in Iowa Code section 321N.2(5).

[ARC 6491C, IAB 9/7/22, effective 10/12/22]

These rules are intended to implement Iowa Code sections 321.515 and 321.519 and chapter 321N.

[Filed ARC 2987C (Notice ARC 2907C, IAB 1/18/17), IAB 3/15/17, effective 4/19/17]

[Filed ARC 3688C (Notice ARC 3572C, IAB 1/17/18), IAB 3/14/18, effective 4/18/18]

[Editorial change: IAC Supplement 8/11/21]

[Filed ARC 5893C (Notice ARC 5621C, IAB 5/19/21), IAB 9/8/21, effective 10/13/21]

[Filed ARC 6491C (Notice ARC 6312C, IAB 5/4/22), IAB 9/7/22, effective 10/12/22]



CHAPTERS 541 to 599  
Reserved



*DRIVER LICENSES*  
CHAPTER 600  
GENERAL INFORMATION

[Prior to 6/3/87, Transportation Department[820]—(07,C)Ch 13]

**761—600.1(321) Definitions.** The definitions in Iowa Code section 321.1 and the following definitions apply to the rules in 761—Chapters 600 to 699.

“*Director of the motor vehicle division*” includes the director’s designee.

“*License*” means “driver’s license” as defined in Iowa Code section 321.1(20A) unless the context otherwise requires.

This rule is intended to implement Iowa Code section 321.1.

[ARC 0661C, IAB 4/3/13, effective 5/8/13; ARC 4586C, IAB 7/31/19, effective 9/4/19; Editorial change: IAC Supplement 12/28/22]

**761—600.2(17A) Information and location.** Applications, forms and information concerning driver’s licensing are available at any driver’s license service center. Assistance is also available by mail from the Motor Vehicle Division, Iowa Department of Transportation, P.O. Box 9204, Des Moines, Iowa 50306-9204; in person at 6310 SE Convenience Blvd., Ankeny, Iowa; by telephone at (515)244-8725; by facsimile at (515)239-1837; or on the department’s website at [www.iowadot.gov](http://www.iowadot.gov).

This rule is intended to implement Iowa Code section 17A.3.

[ARC 4586C, IAB 7/31/19, effective 9/4/19; Editorial change: IAC Supplement 12/28/22]

**761—600.3(321) Seat belt exemptions.**

**600.3(1)** A person who is unable to wear a safety belt or safety harness for physical or medical reasons may obtain a form to be signed by the person’s health care provider licensed under Iowa Code chapter 148 or 151. Form No. 432017, “Iowa Medical Safety Belt Exemption,” is available from the motor vehicle division.

**600.3(2)** Iowa Code sections 321.445(1) and 321.445(2) shall not apply to the front seats and front seat passengers of motor vehicles owned, leased, rented or primarily used by a person with a physical disability who uses a collapsible wheelchair.

This rule is intended to implement Iowa Code section 321.445.

[ARC 9991B, IAB 2/8/12, effective 3/14/12; ARC 4586C, IAB 7/31/19, effective 9/4/19; Editorial change: IAC Supplement 12/28/22]

**761—600.4(252J,261,321) Persons not to be licensed.** Rescinded ARC 4586C, IAB 7/31/19, effective 9/4/19. See rule 761—605.4(252J,321).

[761—Chapter 600 appeared as Ch 13, Department of Public Safety, 1973 IDR;  
amended July 1973, January 1974 and July 1974 Supplements]

[Filed 7/1/75]

[Filed 12/28/76, Notice 11/3/76—published 1/12/77, effective 2/16/77]

[Filed emergency 7/28/78—published 8/23/78, effective 8/1/78]

[Filed 2/8/79, Notice 12/27/78—published 3/7/79, effective 4/11/79]

[Filed 2/12/80, Notice 12/26/79—published 3/5/80, effective 4/9/80]

[Filed 2/27/80, Notice 1/9/80—published 3/19/80, effective 4/23/80]

[Filed 8/25/80, Notice 7/9/80—published 9/17/80, effective 10/22/80]

[Filed 4/17/81, Notice 3/4/81—published 5/13/81, effective 6/17/81]

[Filed 5/19/81, Notice 4/1/81—published 6/10/81, effective 7/15/81]

[Filed emergency 9/17/81—published 10/14/81, effective 9/17/81]

[Filed 10/2/81, Notice 8/19/81—published 10/28/81, effective 12/2/81]

[Filed emergency 5/27/82—published 6/23/82, effective 7/1/82]

[Filed 12/1/82, Notice 6/23/82—published 12/22/82, effective 1/26/83]

[Filed 12/1/82, Notice 10/13/82—published 12/22/82, effective 1/26/83]◊

[Filed emergency 6/20/84—published 7/18/84, effective 7/1/84]

[Filed 4/17/85, Notice 2/27/85—published 5/8/85, effective 6/12/85]

[Filed 11/27/85, Notice 10/9/85—published 12/18/85, effective 1/22/86]

[Filed emergency 6/20/86—published 7/16/86, effective 7/1/86]

[Filed 5/11/87, Notice 3/11/87—published 6/3/87, effective 7/8/87]◊

[Filed 9/25/87, Notice 7/29/87—published 10/21/87, effective 11/25/87]

[Filed 1/20/88, Notice 12/2/87—published 2/10/88, effective 3/16/88]◊

[Filed 9/21/89, Notice 7/26/89—published 10/18/89, effective 11/22/89]  
[Filed emergency 11/30/89—published 12/27/89, effective 12/1/89]  
[Filed emergency 6/7/90—published 6/27/90, effective 7/1/90]  
[Filed emergency 8/8/90—published 9/5/90, effective 8/10/90]  
[Filed 12/18/91, Notice 11/13/91—published 1/8/92, effective 2/12/92]  
[Filed 11/4/93, Notice 9/29/93—published 11/24/93, effective 12/29/93]  
[Filed 11/1/95, Notice 9/27/95—published 11/22/95, effective 12/27/95]  
[Filed 10/30/96, Notice 9/25/96—published 11/20/96, effective 12/25/96]  
[Filed 1/21/98, Notice 12/17/97—published 2/11/98, effective 3/18/98]  
[Filed 10/28/98, Notice 9/23/98—published 11/18/98, effective 12/23/98]<sup>1</sup>  
[Filed 6/19/02, Notice 4/17/02—published 7/10/02, effective 8/14/02]  
[Filed 3/10/04, Notice 2/4/04—published 3/31/04, effective 5/5/04]  
[Filed 12/12/07, Notice 11/7/07—published 1/2/08, effective 2/6/08]  
[Filed ARC 9991B (Notice ARC 9874B, IAB 11/30/11), IAB 2/8/12, effective 3/14/12]  
[Filed ARC 0661C (Notice ARC 0571C, IAB 1/23/13), IAB 4/3/13, effective 5/8/13]  
[Filed ARC 4586C (Notice ARC 4476C, IAB 6/5/19), IAB 7/31/19, effective 9/4/19]  
[Editorial change: IAC Supplement 12/28/22]

◇ Two or more ARCs

<sup>1</sup> Effective date of 761—600.13(321) delayed 70 days by the Administrative Rules Review Committee at its meeting held December 9, 1998. At its meeting held January 5, 1999, the Committee delayed the effective date until adjournment of the 1999 Session of the General Assembly.

CHAPTER 601  
APPLICATION FOR LICENSE

**761—601.1(321) Application for license.**

**601.1(1) General.** In addition to the information required under Iowa Code sections 321.182 and 321.196, the information in this rule is required from an applicant for a driver's license. Additional requirements for a commercial driver's license are found in 761—Chapter 607.

**601.1(2) Name.** The applicant's full legal name shall be given on the application. Full legal name means an individual's first name, middle name(s), and last name, without use of initials or nicknames. Civilian and military titles, initials and nicknames shall not be given and shall not be used on the applicant's license or in the applicant's record. This prohibition on the use of initials does not apply where a portion of an individual's legal name, whether first, middle or last, consists of a single character, whether followed by a period or not.

**601.1(3) Out-of-state verification.** Upon application for a driver's license, the department shall ascertain whether the applicant has ever held, or is the holder of, a driver's license issued by any other state.

*a.* The department shall not issue a driver's license to the applicant if:

(1) The applicant has held a driver's license issued by any other state, but the driver's license has been suspended by reason, in whole or part, of a violation and if such suspension period has not terminated.

(2) The applicant has held a driver's license issued by any other state, but the driver's license has been revoked by reason, in whole or part, of a violation and if such revocation has not terminated, except that after the expiration of one year from the date the license was revoked, the applicant may make application for a new license if permitted by law. The department may refuse to issue a license to any such applicant if, after investigation, the department determines that it will not be safe to grant such applicant the privilege of driving a motor vehicle on the highways.

(3) The applicant is the holder of a driver's license issued by another state and currently in force, unless the applicant surrenders such license.

*b.* If the applicant is subject to subparagraph 601.1(3)"a"(2) or has committed an offense or acted in a manner in another state which in Iowa would be grounds for revocation and it has been more than one year from the date the license or driving privilege was revoked, the department may issue the applicant a driver's license only upon such terms and conditions and subject to such restrictions or limitations as if the violation had been committed and the revocation imposed in Iowa. The department shall delay licensing or restrict licensing for such period of time that the applicant would be ineligible for a driving privilege or subject to a restricted driving privilege if the violation had been committed and the revocation imposed in Iowa.

(1) For purposes of determining whether it is safe to grant the applicant a driving privilege, an applicant may be determined to be safe only if the department determines all of the following:

1. The applicant has satisfied the same requirements for the grant of a driving privilege if the violation had been committed and the revocation imposed in Iowa.

2. The applicant is otherwise physically and mentally capable of safely operating a motor vehicle.

(2) However, the department shall not assess a civil penalty to the applicant as a condition of licensing under this subrule.

(3) Pursuant to Iowa Code section 321.13, the department may make further investigation or require further information necessary to determine whether it is safe to grant the applicant a driving privilege.

*c.* If the applicant is licensed in another state but does not have a current out-of-state license to surrender, the department may require verification of the applicant's driving record from the state of record, which may be accomplished electronically where possible, to assist the department in determining whether it is safe to grant the applicant a license.

**601.1(4) Disabilities.** The applicant shall indicate and explain any mental or physical disabilities which might affect the applicant's ability to operate a motor vehicle safely. The department may make further inquiries of the applicant or require further information necessary to determine whether it is safe to grant the applicant a driving privilege, including but not limited to requesting an examination authorized under Iowa Code section 321.186.

**601.1(5) Physical description.** The applicant shall provide the applicant's physical description, which shall consist of the applicant's sex, height to the nearest inch, weight to the nearest pound, and eye color.

**601.1(6) Address.** The applicant shall provide the applicant's current residential address and the applicant's current mailing address, if different from the applicant's current residential address. The applicant shall not provide as a mailing address an address for which a forwarding order with the United States Postal Service is in place. Notwithstanding anything in subrule 601.1(6), an applicant who is a participant in the "safe at home" address confidentiality program administered by the Iowa secretary of state may submit a designated address issued to the applicant by the Iowa secretary of state as the applicant's residential and mailing address.

**601.1(7) Signature.**

*a.* The applicant's signature shall be without qualification and shall contain only the applicant's usual signature without any other titles, characters or symbols.

*b.* The applicant's signature certifies, under penalty of perjury and pursuant to the laws of the state of Iowa, that the statements made and information provided in the applicant's application are true and correct.

*c.* The applicant's signature further certifies that the fee collected and the change returned, if any, is correct and acknowledges that the applicant is aware of the requirement to notify the department of a change in mailing address within 30 days of the change.

*d.* The applicant's signature will be captured electronically.

This rule is intended to implement Iowa Code sections 321.13, 321.177, 321.182, 321.186, 321.196 and 321C.1; Article V, the REAL ID Act of 2005 (49 U.S.C. Section 30301 note); and 6 CFR Part 37.

[ARC 0347C, IAB 10/3/12, effective 11/7/12; ARC 3451C, IAB 11/8/17, effective 12/13/17; ARC 6059C, IAB 12/1/21, effective 1/5/22]

**761—601.2(321) Surrender of license and nonoperator's identification card.** An applicant for a driver's license shall surrender all other driver's licenses and nonoperator's identification cards. This includes those issued by a state other than Iowa or a foreign jurisdiction, unless otherwise provided in a letter of understanding or other written memorialization of reciprocity or understanding. An applicant who renews a driver's license electronically pursuant to 761—subrule 605.25(7) shall destroy the previous driver's license upon receipt of the renewed driver's license.

This rule is intended to implement Iowa Code section 321.182.

[ARC 0895C, IAB 8/7/13, effective 7/9/13; ARC 1073C, IAB 10/2/13, effective 11/6/13; ARC 3451C, IAB 11/8/17, effective 12/13/17]

**761—601.3(321) Emergency contact information.** Pursuant to Iowa Code section 321.197, a person may voluntarily provide the department with emergency contact information.

**601.3(1) Form and submission.**

*a.* Emergency contact information provided to the department shall meet the requirements and be used in the circumstances set forth in Iowa Code section 321.197(2) "b."

*b.* Emergency contact information may be provided to the department through any of the following methods:

(1) By submitting Form 430305 via mail to the Motor Vehicle Division, Iowa Department of Transportation, P.O. Box 9204, Des Moines, Iowa 50306-9204; by email at [emergencyinfo.contact@iowadot.us](mailto:emergencyinfo.contact@iowadot.us); or on the department's website at [www.iowadot.gov](http://www.iowadot.gov).

(2) In person at a driver's license service center.

(3) In person at a county treasurer's office that issues driver's licenses under Iowa Code chapter 321M.

*c.* Pursuant to Iowa Code section 321.197(2) "c," an unemancipated person under 18 years of age choosing to provide emergency contact information shall include a parent, guardian or custodian as an emergency contact.

*d.* The department shall not require submission of emergency contact information as a condition of issuing, renewing or replacing a driver's license.

*e.* In accordance with Iowa Code section 321.197(2) "b," the department will not verify the emergency contact information provided.

**601.3(2) Disclosure and use.** Information provided to the department under subrule 601.3(1) shall be provided to and used by law enforcement in accordance with the provisions of Iowa Code section 321.197.

**601.3(3) Modifications.**

*a.* A person may request changes to the person's emergency contact information by entering those changes on the department's website or by submitting Form 430305 to the department using any of the methods provided in paragraph 601.3(1) "b."

*b.* A person may request to be removed from being listed as an emergency contact by submitting Form 430306 to the department via mail at Motor Vehicle Division, Iowa Department of Transportation, P.O. Box 9204, Des Moines, Iowa 50306-9204, or by email at [emergencyinfo.contact@iowadot.us](mailto:emergencyinfo.contact@iowadot.us). Any person removed from being listed as an emergency contact shall not be re-added as a potential emergency contact unless such person follows the opt-in process in paragraph 601.3(3) "c."

*c.* A person who requested to be removed from being listed as an emergency contact under paragraph 601.3(3) "b" may request to again be listed as a person's emergency contact by submitting Form 430306 to the department via mail at Motor Vehicle Division, Iowa Department of Transportation, P.O. Box 9204, Des Moines, Iowa 50306-9204, or by email at [emergencyinfo.contact@iowadot.us](mailto:emergencyinfo.contact@iowadot.us).

This rule is intended to implement Iowa Code section 321.197.

[ARC 6306C, IAB 5/4/22, effective 6/8/22]

**761—601.4** Reserved.

**761—601.5(321) Proofs submitted with application.** A person who applies for a new Iowa driver's license or nonoperator's identification card, including a person who currently holds a license or card issued by another state or foreign jurisdiction, shall submit proof of identity, date of birth, social security number, Iowa residency and current residential address, and lawful status in the United States.

**601.5(1) Verification of identity and date of birth.** To establish identity and date of birth, an applicant must submit at least one of the following documents. The department may require additional documentation if the department believes that the documentation submitted is questionable or if the department has reason to believe that the person is not who the person claims to be.

- a. A valid, unexpired U.S. passport or U.S. passport card.
- b. A certified copy of a birth certificate and, if applicable, a certified amended or new birth certificate showing a change in name, date of birth, or sex, filed with a state office of vital statistics or equivalent agency in the applicant's state of birth. The birth certificate must bear the issuing authority's certification of authenticity. A hospital-issued certificate is not acceptable. As used herein, "state" means a state of the United States, the District of Columbia, Puerto Rico, the Virgin Islands, Guam, American Samoa, and the Commonwealth of the Northern Mariana Islands.
- c. A Consular Report of Birth Abroad issued by the U.S. Department of State (Form FS-240, DS-1350 or FS-545).
- d. A valid, unexpired Permanent Resident Card (Form I-551) issued by the U.S. Department of Homeland Security or U.S. Immigration and Naturalization Service.
- e. An unexpired employment authorization document issued by the U.S. Department of Homeland Security (Form I-766 or Form I-688B).
- f. An unexpired foreign passport with a U.S. visa affixed, accompanied by the approved I-94 form documenting the applicant's most recent admittance into the United States.
- g. A Certificate of Naturalization issued by the U.S. Department of Homeland Security (Form N-550 or Form N-570).
- h. A Certificate of Citizenship (Form N-560 or Form N-561) issued by the U.S. Department of Homeland Security.
- i. A REAL ID driver's license or identification card issued in compliance with the standards established by 6 CFR Part 37.
- j. Such other documents as the U.S. Department of Homeland Security may designate as acceptable proof of identity and date of birth for REAL ID purposes by notice published in the Federal Register.
- k. An Inmate Descriptor Inquiry, Client Information Inquiry or Offender Snapshot document issued by the Iowa department of corrections or the United States District Court, Northern and Southern Districts of Iowa. The document must contain the applicant's full legal name and date of birth and be notarized. An applicant who provides only a document listed in this paragraph shall not be eligible for a driver's license or nonoperator's identification card marked as acceptable for federal purposes under 6 CFR Part 37.

**601.5(2) Verification of social security number.**

- a. Except as provided in paragraph 601.5(2)"b," an applicant must present proof of the applicant's Social Security Administration's account number.
- b. An applicant who establishes identity by presenting the identity document listed in paragraph 601.5(1)"f" (unexpired foreign passport with a valid, unexpired U.S. visa affixed and accompanied by the approved I-94 form documenting the applicant's most recent admittance into the United States) must present proof of the applicant's social security number or demonstrate non-work authorized status.

**601.5(3) Verification of Iowa residency and current residential address.**

- a. To document Iowa residency and current residential address, an applicant must present two documents that include the applicant's name and current Iowa residential address and that demonstrate residency in the state of Iowa. Acceptable documents are documents issued by a person, organization, or entity other than the applicant, that include the issuer's name and address, include the applicant's name and current residential address, and demonstrate residency in the state of Iowa. The documents must be reasonable, authentic documents capable of verification by the department.
- b. The address must be a street or highway address, and may not be a post office box. In areas where a number and street name have not been assigned, an address convention used by the U.S. Postal Service is acceptable. The current residence of a person with more than one dwelling is the dwelling for which the person claims a homestead tax credit under Iowa Code chapter 425, if applicable.
- c. An applicant who is a member of the armed forces and is an Iowa resident stationed in another state may use the applicant's address in the state of station as the applicant's current residential address if the applicant does not maintain an Iowa residence during the applicant's deployment outside the state of Iowa. The applicant must provide

official documentation confirming the applicant's residential address in the state of station and that the applicant is stationed in that state. The applicant's mailing address may be the applicant's current residential address or another address at which the applicant receives mail.

*d.* An applicant who is a dependent family member of and resides with a member of the armed forces who is an Iowa resident stationed in another state may use the applicant's address in the state of station as the applicant's current residential address if the applicant does not maintain an Iowa residence during the applicant's deployment outside the state of Iowa. The applicant must provide official documentation confirming the applicant's residential address in the state of station and that the applicant is a dependent family member of a member of the armed forces stationed in that state. The applicant's mailing address may be the applicant's current residential address or another address at which the applicant receives mail.

**601.5(4)** *Verification of lawful status in the United States.*

*a.* If an applicant presents one of the identity documents listed under subrule 601.5(1), the department's verification of that identity document is satisfactory evidence of lawful status.

*b.* An applicant who presents only a document listed under subrule 601.5(1), paragraph "e," "f," or "i," is not eligible to receive a driver's license or nonoperator's identification card marked as REAL ID compliant unless the applicant also provides one of the other documents listed in subrule 601.5(1), or another United States Department of Homeland Security-approved document.

**601.5(5)** *Verification of name change.* The name listed on the driver's license or nonoperator's identification card that is issued shall be identical to the name listed on the identity document submitted unless the applicant submits the chain of legal documents necessary to show the legal change of the applicant's name from the identity document submitted to the applicant's current legal name under paragraph 601.5(5) "a" or "b." Alternatively, an applicant who is an existing Iowa licensee or cardholder may confirm the applicant's current legal name as displayed on the applicant's license or card under the requirements of paragraph 601.5(5) "c." The following documents are acceptable:

*a.* Court-ordered name change. A court order must contain the applicant's prior legal name, the applicant's court-ordered legal name, and the court's certification of authenticity. Acceptable court orders include orders under petition for name change, orders for name change set forth in a decree of dissolution, and orders for name change set forth in a decree of adoption.

*b.* Certified copy of marriage certificate. The marriage certificate must be filed with a state office of vital statistics or equivalent agency in the person's state or country of marriage. The certificate must bear the issuing authority's certification of authenticity. A church, chapel or similarly issued certificate is not acceptable. As used herein, "state" means a state of the United States, the District of Columbia, Puerto Rico, the Virgin Islands, Guam, American Samoa, and the Commonwealth of the Northern Mariana Islands.

*c.* Social security records match. The applicant must establish that the applicant's Social Security Administration's account number is issued in the applicant's current legal name as verified by the department with the Social Security Online Verification (SSOLV) system in accordance with 6 CFR Section 37.13(b)(2).

**601.5(6)** *Verification of change of date of birth.* The date of birth listed on the driver's license or nonoperator's identification card that is issued shall be identical to the date of birth listed on the identity document submitted unless the applicant submits a certified amended or new birth certificate that documents the change of date of birth and that meets the requirements of paragraph 601.5(1) "b."

**601.5(7)** *Verification of change of sex designation.* The sex designation listed on the driver's license or nonoperator's identification card that is issued shall be identical to the sex designation listed on the identity document submitted unless the applicant does one of the following:

*a. Applicants born in Iowa.* An applicant born in Iowa must submit a certified amended or new Iowa birth certificate that documents the change of sex designation and that meets the requirements of paragraph 601.5(1) "b."

*b. Applicants born outside of Iowa.*

(1) An applicant born outside of Iowa may document the change of sex designation by any of the following methods:

1. Submit a certified amended or new birth certificate from a state other than Iowa that documents the change of sex designation and that meets the requirements of paragraph 601.5(1) "b."

2. Submit an amended or new Consular Report of Birth Abroad that documents the change of sex designation and meets the requirements of paragraph 601.5(1) "c."

3. Submit an amended or new Certificate of Citizenship that documents the change of sex designation and meets the requirements of paragraph 601.5(1) "h."

4. Submit a notarized affidavit from a physician and surgeon or osteopathic physician and surgeon that documents all of the following:

- The physician and surgeon or osteopathic physician and surgeon completed sex designation treatment for the applicant.

- A description of the medical procedures that constituted the treatment.

- As a result of the treatment, the applicant's sex designation was permanently changed by surgery or other treatment.

- The physician and surgeon or osteopathic physician and surgeon's full name, address, state of medical license, and medical license number.

(2) Pursuant to Iowa Code section 321.13, the department may make further investigation or require further information necessary to determine whether a change of sex designation occurred.

*c. Documentation.* Documentation provided under this subrule shall be submitted to the Motor Vehicle Division, Iowa Department of Transportation, P.O. Box 9204, Des Moines, Iowa 50306-9204.

*d. Name change.* A change of sex designation shall not effect a name change unless the applicant verifies a name change pursuant to subrule 601.5(5).

**601.5(8) Exception process.** As provided in 6 CFR Section 37.11(h) (REAL ID exceptions process), and notwithstanding any other provisions of this chapter or 761—Chapter 11 to the contrary, an applicant who, for reasons beyond the applicant's control, is unable to present a necessary document under this rule may apply to the department for an exception as provided in this subrule.

*a.* To apply for an exception under this rule, an applicant shall do all of the following:

(1) Submit an application to the department in a manner prescribed by the department. The application shall contain all of the following:

1. The applicant's name, address, date of birth and contact information.

2. Whether the applicant is applying for a driver's license or nonoperator's identification card.

3. A description of the necessary verification of identity and date of birth or verification of name change documents under this rule that the applicant is unable to provide and the reason why it is beyond the applicant's control to provide the document.

4. Any alternate document or other proof that exists to verify the facts contained in the missing document, which may include an approved I-94 form documenting the applicant's most recent admittance into the United States as verified by the U.S. Department of Homeland Security in accordance with 6 CFR Section 37.13.

5. Any other information or proof required by the department.

*b.* The motor vehicle division director or the director's designee may grant an exception under this rule if all of the following apply:

(1) The applicant has submitted an application with all of the required documentation under paragraph "a."

(2) The applicant, as determined by the department, has sufficiently demonstrated that the applicant is unable to provide a necessary document under this rule due to reasons beyond the applicant's control.

(3) The application of the subject rule will pose an undue hardship on the applicant, as determined by the department.

(4) Granting the exception will not prejudice the substantial legal rights of any person, as determined by the department.

*c.* The department may place any condition on an exception issued under this rule that the department finds necessary to carry out the department's functions under the REAL ID Act of 2005 as amended by the REAL ID Modernization Act, H.R. 133, Division U, Title X.

*d.* An exception under this subrule shall not apply to a required document under subrule 601.5(2).

*e.* An alternate document accepted under this exception process to satisfy the requirements of subrule 601.5(4) is only allowed if the document demonstrates United States citizenship as required by 6 CFR Section 37.11(h).

*f.* An applicant's inability to pay for a necessary document under this rule does not meet the criteria for an exception under this subrule.

*g.* Nothing in this subrule shall require the department to issue a driver's license or nonoperator's identification card if the applicant is not otherwise eligible for a license or card. The department reserves the right to modify or cancel an exception at any time if the department finds that anything in the exception application or accompanying documentation was based on fraud or misrepresentation by the applicant, or if the modification or cancellation is necessary based on a change in circumstances of the applicant.

*h.* The application and documentation provided under this subrule shall be submitted to the Motor Vehicle Division, Iowa Department of Transportation, P.O. Box 9204, Des Moines, Iowa 50306-9204, or through electronic means determined by the department. The director of the motor vehicle division or the director's designee may, in response to an application submitted under this subrule, grant or deny an application for exception in accordance with this subrule.

*i.* An applicant whose application for exception under this rule has been denied may contest the decision in accordance with Iowa Code chapter 17A and 761—Chapter 13. The request for a hearing shall be submitted in writing to the motor vehicle division. The request shall include, as applicable, the applicant's name, driver's license or nonoperator's identification number, date of birth, complete address and telephone number. The request must be submitted within 20 days after the date of the notice of exception denial.

This rule is intended to implement Iowa Code chapter 17A and sections 321.13, 321.182 and 321.189; the REAL ID Act of 2005 (49 U.S.C. Section 30301 note) as amended by the REAL ID Modernization Act, H.R. 133, Division U, Title X; and 6 CFR Part 37.

[ARC 7902B, IAB 7/1/09, effective 8/5/09; ARC 0347C, IAB 10/3/12, effective 11/7/12; ARC 3451C, IAB 11/8/17, effective 12/13/17; ARC 6059C, IAB 12/1/21, effective 1/5/22]

**761—601.6(321) Parent's, guardian's or custodian's consent.** The application of an unmarried person under the age of 18 years shall contain the verified consent and confirmation of the applicant's birthday and shall be signed by either parent of the applicant, the guardian of the applicant, or a person having custody of the applicant under Iowa Code chapter 232 or 600A. Consent and confirmation shall be proved by submission of Form 430018, Parent's, Guardian's or Custodian's Consent to Issue Driver's License or Permit, or its equivalent in an electronic format to be determined by the department. The signature, which may be electronic, shall be dated and shall be subject to the following verification or its equivalent: "I certify under penalty of perjury and pursuant to the laws of the state of Iowa that the preceding is true and correct." No exception shall be made for the parent's, guardian's or custodian's absence from Iowa. A married person under the age of 18 years shall submit a marriage certificate that meets the requirements of paragraph 601.5(5) "b" to avoid submission of the consent form.

This rule is intended to implement Iowa Code section 321.184.

[ARC 7902B, IAB 7/1/09, effective 8/5/09; ARC 3451C, IAB 11/8/17, effective 12/13/17]

**761—601.7(321) REAL ID driver's license.** A person who seeks a driver's license that is compliant with the REAL ID Act of 2005, 49 U.S.C. §30301 note, as further defined in 6 CFR Part 37 ("REAL ID driver's license"), must meet and comply with all lawful requirements for an Iowa driver's license, and must also meet and comply with all application and documentation requirements set forth at 6 CFR Part 37, including but not limited to documentation of identity, date of birth, social security number, address of principal residence, and evidence of lawful status in the United States. Documents and information provided to fulfill REAL ID requirements must be verified as required in 6 CFR 37.13. An applicant for a REAL ID driver's license is subject to a mandatory facial image capture that meets the requirements of 6 CFR 37.11(a). A REAL ID driver's license may not be issued, reissued, or renewed except as permitted in 6 CFR Part 37 and may not be issued, reissued, or renewed by any procedure, in any circumstance, to any person, or for any term prohibited under 6 CFR Part 37. The information on the front of any REAL ID driver's license must include all information and markings required by 6 CFR 37.17. Nothing in this rule requires a person to obtain a REAL ID driver's license.

This rule is intended to implement Iowa Code chapter 321, the REAL ID Act of 2005 (49 U.S.C. Section 30301 note), and 6 CFR Part 37.

[ARC 8339B, IAB 12/2/09, effective 12/21/09; ARC 8514B, IAB 2/10/10, effective 3/17/10]

[Filed emergency 6/7/90—published 6/27/90, effective 7/1/90]

[Filed 12/18/91, Notice 11/13/91—published 1/8/92, effective 2/12/92]

[Filed 11/1/95, Notice 9/27/95—published 11/22/95, effective 12/27/95]

[Filed 10/30/96, Notice 9/25/96—published 11/20/96, effective 12/25/96]

[Filed emergency 4/3/97—published 4/23/97, effective 4/3/97]

[Filed 1/21/98, Notice 12/17/97—published 2/11/98, effective 3/18/98]

[Filed 10/28/98, Notice 9/23/98—published 11/18/98, effective 12/23/98]

[Filed 2/15/02, Notice 12/26/01—published 3/20/02, effective 4/24/02]

[Filed 6/19/02, Notice 4/17/02—published 7/10/02, effective 8/14/02]

[Filed ARC 7902B (Notice ARC 7721B, IAB 4/22/09), IAB 7/1/09, effective 8/5/09]

[Filed Emergency ARC 8339B, IAB 12/2/09, effective 12/21/09]

[Filed ARC 8514B (Notice ARC 8342B, IAB 12/2/09), IAB 2/10/10, effective 3/17/10]

[Filed ARC 0347C (Notice ARC 0201C, IAB 7/11/12), IAB 10/3/12, effective 11/7/12]

[Filed Emergency ARC 0895C, IAB 8/7/13, effective 7/9/13]

[Filed ARC 1073C (Notice ARC 0894C, IAB 8/7/13), IAB 10/2/13, effective 11/6/13]

[Filed ARC 3451C (Notice ARC 3307C, IAB 9/13/17), IAB 11/8/17, effective 12/13/17]

[Filed ARC 6059C (Notice ARC 5924C, IAB 9/22/21), IAB 12/1/21, effective 1/5/22]

[Filed ARC 6306C (Notice ARC 6200C, IAB 2/23/22), IAB 5/4/22, effective 6/8/22]



CHAPTER 602  
CLASSES OF DRIVER'S LICENSES

**761—602.1(321) Driver's licenses.**

**602.1(1) *Classes.*** The department issues the following classes of driver's licenses. All licenses issued, including special licenses and permits, shall carry a class designation. A license shall be issued for only one class, except that Class M may be issued in combination with another class.

- Class A—commercial driver's license (CDL)
- Class B—commercial driver's license (CDL)
- Class C—commercial driver's license (CDL)
- Class C—noncommercial driver's license
- Class D—noncommercial driver's license (chauffeur)
- Class M—noncommercial driver's license (motorcycle)

**602.1(2) *Special licenses and permits.*** The department issues the following special licenses and permits. More than one type of special license or permit may be issued to an applicant. On the driver's license, a restriction number designates the type of special license or permit issued, as follows:

- 1—Motorcycle instruction permit—includes motorcycle instruction permits issued under Iowa Code subsections 321.180(1) and 321.180B(1)
- 2—Noncommercial instruction permit (vehicle less than 16,001 gross vehicle weight rating)—includes instruction permits, other than motorcycle instruction permits, issued under Iowa Code subsection 321.180(1), section 321.180A and subsection 321.180B(1)
- 3—Commercial learner's permit
- 4—Chauffeur's instruction permit
- 5—Motorized bicycle license
- 6—Minor's restricted license
- 7—Minor's school license

**602.1(3) *Commercial driver's license (CDL).*** See 761—Chapter 607 for information on the procedures, requirements and validity of a commercial driver's license (Classes A, B and C) and a commercial learner's permit, and their restrictions and endorsements.

This rule is intended to implement Iowa Code sections 321.178, 321.180, 321.180A, 321.180B, 321.189, and 321.194.

[ARC 2071C, IAB 8/5/15, effective 7/14/15; ARC 2337C, IAB 1/6/16, effective 2/10/16; ARC 2644C, IAB 8/3/16, effective 9/7/16]

**761—602.2(321) Information and forms.** Applications, forms and information about driver's licensing are available at any driver's license service center. Assistance is also available by mail from the Motor Vehicle Division, Iowa Department of Transportation, P.O. Box 9204, Des Moines, Iowa 50306-9204; in person at 6310 SE Convenience Blvd., Ankeny, Iowa; by telephone at (515)244-8725; by facsimile at (515)239-1837; or on the department's website at [www.iowadot.gov](http://www.iowadot.gov).

**602.2(1) *Certificate of completion.*** Proof of successful completion of an Iowa-approved course in driver education, motorcycle rider education, or motorized bicycle education shall be submitted to the department on Form 430036 or through an online reporting system used by participating Iowa-approved driver education, motorcycle rider education, or motorized bicycle rider education providers.

*a.* If a student completed a course in another state, a public or licensed commercial or private provider of the Iowa-approved course may issue the form or online completion, if applicable, for the student if the provider determines that the out-of-state course is comparable to the Iowa-approved course.

*b.* If the out-of-state course is comparable but lacks certain components of the Iowa-approved course, the provider may issue the form or online completion, if applicable, after the student completes the missing components.

**602.2(2) *Affidavit for school license.*** Form 430021 shall be used for submitting the required statements, affidavits and parental consent for a minor's school license. See rule 761—602.26(321).

**602.2(3) *Waiver of accompanying driver for intermediate licensee.*** Form 431170 is the waiver described in Iowa Code subsection 321.180B(2). This form allows an intermediate licensee to drive unaccompanied between the hours of 12:30 a.m. and 5 a.m. and must be in the licensee's possession when the licensee is driving during the hours to which the waiver applies.

*a.* If the waiver is for employment, the form must be signed by the licensee's employer.

*b.* If the licensee attends a public school and the waiver is for school-related extracurricular activities, the form must be signed by the chairperson of the school board, the superintendent of the school, or the principal of the school

if authorized by the superintendent. If the licensee attends an accredited nonpublic school and the waiver is for school-related extracurricular activities, the form must be signed by an authority in charge of the accredited nonpublic school or a duly authorized representative of the authority.

c. The form must be signed by the licensee's parent or guardian. However, the parent's or guardian's signature is not required if the licensee is married and the original or a certified copy of the marriage certificate is in the licensee's possession when the licensee is driving during the hours to which the waiver applies.

**602.2(4) Passenger restriction for intermediate licensee.** The passenger restriction required by Iowa Code section 321.180B(2) will be added to an intermediate license unless waived by the licensee's parent or guardian at the time the license is issued. If the restriction is not waived at the time the license is issued, the intermediate license will be designated with a "9" restriction with the following notation: "Only 1 unrelated minor passenger allowed until [six months from the date the license is issued]." The licensee must obey the restriction for the first six months after the intermediate license is issued. If a parent or guardian wishes to waive the passenger restriction after the license has already been issued, the licensee and the parent or guardian must apply for a duplicate license and pay the replacement fee pursuant to 761—subrule 605.11(4).

This rule is intended to implement Iowa Code sections 321.8, 321.178, 321.180B, 321.184, 321.189, and 321.194. [ARC 7902B, IAB 7/1/09, effective 8/5/09; ARC 2644C, IAB 8/3/16, effective 9/7/16; ARC 4271C, IAB 1/30/19, effective 3/6/19; ARC 4759C, IAB 11/6/19, effective 12/11/19; ARC 4851C, IAB 1/1/20, effective 2/5/20; ARC 5204C, IAB 10/7/20, effective 11/11/20; ARC 5258C, IAB 11/4/20, effective 12/9/20; Editorial change: IAC Supplement 12/28/22]

**761—602.3** Reserved.

**761—602.4(321) Definitions of immediate family.**

**602.4(1)** A "member of the permittee's immediate family" as used in Iowa Code subsection 321.180(1) means the permittee's parent or guardian or a brother, sister or other relative of the permittee who resides at the permittee's residence.

**602.4(2)** A "member of the permittee's immediate family" as used in Iowa Code section 321.180B, subsections 1 and 2, means a brother, sister or other relative of the permittee who resides at the permittee's residence.

This rule is intended to implement Iowa Code sections 321.180 and 321.180B.

**761—602.5 to 602.10** Reserved.

**761—602.11(321) Class C noncommercial driver's license.** This rule describes a noncommercial Class C driver's license that is not a special license or permit.

**602.11(1) Validity and issuance.**

a. The license is valid for operating:

(1) A motor vehicle, including an autocycle as defined in Iowa Code section 321.1, that does not require a commercial driver's license or a Class D driver's license for its operation.

(2) A motorized bicycle.

(3) A motorcycle only if the license has a motorcycle endorsement.

b. The license is issued for either two years or eight years.

(1) A qualified applicant who is at least 17 years, 11 months of age but not yet 78 years of age shall be issued an eight-year license. However, the expiration date of the license issued shall not exceed the licensee's 80th birthday.

(2) A two-year license shall be issued to a qualified applicant who is under 17 years, 11 months of age or who is 78 years of age or older.

(3) A two-year license may also be issued, at the discretion of the department, to an applicant whose license is restricted due to vision or other physical disabilities.

**602.11(2) Requirements.**

a. An applicant shall be at least 16 years of age.

b. Except as otherwise provided in Iowa Code subsection 321.178(3), an applicant under 18 years of age must meet the requirements of Iowa Code section 321.180B and submit proof of successful completion of an Iowa-approved course in driver education.

c. For purposes of determining eligibility for an intermediate license issued to a person 16 or 17 years of age under Iowa Code subsection 321.180B(2):

(1) The 12-month period during which the applicant is required to possess an instruction permit before applying for an intermediate license shall be calculated cumulatively and shall include any period of time during which the applicant has held a valid instruction permit issued under Iowa Code subsection 321.180B(1), a minor's school license issued under Iowa Code section 321.194, or comparable instruction permit or license issued by another state, but shall

exclude any period of time during which the permit or license is suspended, revoked, or canceled, or the applicant otherwise did not have a valid driving privilege.

(2) The six-month period during which the applicant is required to remain accident and violation free shall be calculated continuously and must encompass without interruption the six-month period of time immediately preceding the application. The applicant must hold a valid instruction permit issued under Iowa Code subsection 321.180B(1), a minor's school license issued under Iowa Code section 321.194, or a comparable instruction permit or license issued by another state and maintain a valid driving privilege without interruption throughout the continuous six-month period.

d. For purposes of determining eligibility for a full license issued to a person 17 years of age under Iowa Code subsection 321.180B(4), the 12-month period during which the applicant is required to possess an intermediate license and to remain accident and violation free before applying for a full license shall be calculated together and continuously and must encompass without interruption the 12-month period of time immediately preceding the application. The applicant must hold a valid intermediate license issued under Iowa Code subsection 321.180B(2) or a comparable license issued by another state and maintain a valid driving privilege without interruption throughout the continuous 12-month period.

This rule is intended to implement Iowa Code sections 321.1, 321.177, 321.178, 321.180B, 321.189 and 321.196.

[ARC 1714C, IAB 11/12/14, effective 12/17/14; ARC 2644C, IAB 8/3/16, effective 9/7/16; ARC 2985C, IAB 3/15/17, effective 4/19/17; ARC 5495C, IAB 3/10/21, effective 4/14/21]

**761—602.12(321) Class D noncommercial driver's license (chauffeur).** This rule describes a noncommercial Class D driver's license.

**602.12(1) Validity and issuance.**

a. The license is valid for operating:

(1) A motor vehicle as a chauffeur as specified by the endorsement on the license, unless the type of vehicle or type of operation requires a commercial driver's license.

(2) A motor vehicle that may be legally operated under a noncommercial Class C driver's license, including a motorized bicycle.

(3) A motorcycle only if the license has a motorcycle endorsement.

b. The license shall have one endorsement authorizing a specific type of motor vehicle or type of operation, as listed in 761—subrule 605.7(3).

c. The license is issued for either two years or eight years.

(1) A qualified applicant who is at least 18 years of age but not yet 78 years of age shall be issued an eight-year license. However, the expiration date of the license issued shall not exceed the licensee's 80th birthday.

(2) A two-year license shall be issued to a qualified applicant who is 78 years of age or older.

(3) A two-year license may also be issued, at the discretion of the department, to an applicant whose license is restricted due to vision or other physical disabilities.

**602.12(2) Requirements.**

a. An applicant shall be at least 18 years of age.

b. Reserved.

This rule is intended to implement Iowa Code sections 321.1 as amended by 2021 Iowa Acts, House File 389, 321.177, 321.189, and 321.196.

[ARC 1714C, IAB 11/12/14, effective 12/17/14; ARC 2071C, IAB 8/5/15, effective 7/14/15; ARC 2337C, IAB 1/6/16, effective 2/10/16; ARC 4586C, IAB 7/31/19, effective 9/4/19; ARC 5495C, IAB 3/10/21, effective 4/14/21; ARC 5942C, IAB 10/6/21, effective 11/10/21]

**761—602.13(321) Class M noncommercial driver's license (motorcycle).** This rule describes a noncommercial Class M driver's license that is not a special license or permit.

**602.13(1) Validity and issuance.**

a. The license is valid for operating:

(1) A motorcycle. However, the license may have a restriction which limits operation to a three-wheel motorcycle.

(2) A motorized bicycle.

b. The license is issued for either two years or eight years.

(1) A qualified applicant who is at least 17 years, 11 months of age but not yet 78 years of age shall be issued an eight-year license. However, the expiration date of the license issued shall not exceed the licensee's 80th birthday.

(2) A two-year license shall be issued to a qualified applicant who is under 17 years, 11 months of age or who is 78 years of age or older.

(3) A two-year license may also be issued, at the discretion of the department, to an applicant whose license is restricted due to vision or other physical disabilities.

c. An Iowa driver's license issued before March 15, 1968, which is still valid because of an extension, is valid for motorcycles. An Iowa driver's license issued from March 15, 1968, through June 30, 1972, which is still valid because of an extension, is valid for motorcycles unless the back of the license is stamped "Not valid for motorcycles."

**602.13(2) Requirements.**

a. An applicant shall be at least 16 years of age.

b. Except as otherwise provided in Iowa Code subsection 321.178(3), an applicant under 18 years of age must meet the requirements of Iowa Code section 321.180B and submit proof of successful completion of an Iowa-approved course in driver education.

c. An applicant under 18 years of age must submit proof of successful completion of an Iowa-approved course in motorcycle rider education.

This rule is intended to implement Iowa Code sections 321.177, 321.178, 321.180B, 321.189 and 321.196.

[ARC 1714C, IAB 11/12/14, effective 12/17/14; ARC 5495C, IAB 3/10/21, effective 4/14/21]

**761—602.14(321) Transition from five-year to eight-year licenses.** During the period January 1, 2014, to December 31, 2018, the department shall issue qualified applicants otherwise eligible for an eight-year license a five-year, six-year, seven-year, or eight-year license, subject to all applicable limitations for age and ability. The applicable period shall be randomly assigned to the applicant by the department's computerized issuance system based on a distribution formula intended to spread renewal volumes as equally as practical over the eight-year period beginning January 1, 2019, and ending December 31, 2026.

This rule is intended to implement Iowa Code section 321.196.

[ARC 1714C, IAB 11/12/14, effective 12/17/14; ARC 4271C, IAB 1/30/19, effective 3/6/19]

**761—602.15 to 602.17** Reserved.

**761—602.18(321) Motorcycle instruction permit.** This rule describes a motorcycle instruction permit issued under Iowa Code subsection 321.180(1) or 321.180B(1).

**602.18(1) Validity and issuance.**

a. The motorcycle instruction permit is a permit that is added to another driver's license.

b. The permit is valid for operating a motorcycle when the permittee is accompanied by a person specified in Iowa Code subsection 321.180(1) or 321.180B(1), as applicable to the age of the permittee.

c. The permit is not valid for operating a motorized bicycle.

d. The permit is issued for four years and is not renewable.

**602.18(2) Requirement.** An applicant shall be at least 14 years of age.

This rule is intended to implement Iowa Code sections 321.177, 321.180 and 321.180B.

**761—602.19(321) Noncommercial instruction permit.** This rule describes a noncommercial instruction permit, other than a motorcycle instruction permit, issued under Iowa Code subsection 321.180(1) or 321.180B(1).

**602.19(1) Validity and issuance.**

a. The permit is a restricted, noncommercial Class C driver's license.

b. The permit is valid for operating a motor vehicle that may be legally operated under a noncommercial Class C driver's license when the permittee is accompanied by a person specified in Iowa Code subsection 321.180(1) or 321.180B(1), as applicable to the age of the permittee.

c. The permit is not valid for operating a motorized bicycle.

d. The permit is not valid as a motorcycle instruction permit.

e. The permit is issued for four years.

**602.19(2) Requirement.** An applicant shall be at least 14 years of age.

This rule is intended to implement Iowa Code sections 321.177, 321.180 and 321.180B.

**761—602.20** Reserved.

**761—602.21(321) Special noncommercial instruction permit.** This rule describes a special noncommercial instruction permit issued under Iowa Code section 321.180A.

**602.21(1) Validity and issuance.**

*a.* The permit is a restricted, noncommercial Class C driver's license that is issued to a person whose application for driver's license renewal has been denied or whose driver's license has been suspended for incapability due to a physical disability.

*b.* The permit is valid for operating a motor vehicle that may be legally operated under a noncommercial Class C driver's license when the permittee is accompanied by a person specified in Iowa Code section 321.180A.

*c.* The permit is not valid for operating a motorized bicycle.

*d.* The permit is not valid as a motorcycle instruction permit.

*e.* The permit is valid for six months from the date of issuance. It is invalid after the expiration date on the permit.

*f.* The permit may be reissued for one additional six-month period.

**602.21(2) Requirement.** An applicant must submit a medical report as referenced in 761—subrule 605.4(6).

This rule is intended to implement Iowa Code section 321.180A.

[ARC 4586C, IAB 7/31/19, effective 9/4/19]

**761—602.22** Reserved.

**761—602.23(321) Chauffeur's instruction permit.**

**602.23(1) Validity and issuance.**

*a.* A chauffeur's instruction permit is a permit that is added to a Class D license or a noncommercial Class C license that is not a special license or permit.

*b.* The license with the permit is valid for operating:

(1) A motor vehicle that may be legally operated under the class of license (and for Class D, the endorsement) held by the licensee, including a motorized bicycle.

(2) A motor vehicle, other than a commercial motor vehicle or a motorcycle, as a chauffeur if accompanied by a person with a valid Class D license or a commercial driver's license valid for the vehicle being operated.

*c.* The permit is issued for two years.

**602.23(2) Requirements.**

*a.* An applicant shall be at least 18 years of age.

*b.* Reserved.

This rule is intended to implement Iowa Code sections 321.1, 321.177 and 321.180.

**761—602.24(321) Motorized bicycle license.**

**602.24(1) Validity and issuance.**

*a.* A motorized bicycle license is a restricted, noncommercial Class C license.

*b.* The license is valid for operating a motorized bicycle.

*c.* The license is issued for two years.

**602.24(2) Requirements.**

*a.* An applicant shall be at least 14 years of age.

*b.* An applicant under 16 years of age must submit proof of successful completion of an Iowa-approved course in motorized bicycle education.

This rule is intended to implement Iowa Code sections 321.177 and 321.189.

**761—602.25(321) Minor's restricted license.**

**602.25(1) Validity and issuance.**

*a.* A minor's restricted license is a restricted, noncommercial Class C or Class M driver's license.

*b.* The license is valid for driving to and from the licensee's place of employment or to transport dependents to and from temporary care facilities, if necessary to maintain the licensee's present employment.

*c.* The type of motor vehicle that may be operated is controlled by the class of driver's license issued. A Class C minor's restricted license is valid for operating a motorcycle only if the license has a motorcycle endorsement. A minor's restricted license is valid for operating a motorized bicycle only for the purposes specified in paragraph "b" of this subrule.

*d.* The license is issued for two years.

**602.25(2) Requirements.**

*a.* The applicant shall be at least 16 years of age but not yet 18.

*b.* The applicant shall submit to the department a statement from the employer confirming the applicant's employment.

c. Proof of nonattendance is required. Proof of nonattendance is receipt of notification from the appropriate school authority that the applicant does not attend school, as set out in 761—subrule 615.23(2).

d. The applicant shall submit proof of successful completion of an Iowa-approved course in driver education.

e. For a Class M minor's restricted license or a motorcycle endorsement, the applicant shall also submit proof of successful completion of an Iowa-approved course in motorcycle rider education.

This rule is intended to implement Iowa Code sections 299.1B, 321.178, 321.180B, 321.189, 321.196 and 321.213B.

#### **761—602.26(321) Minor's school license.**

##### **602.26(1) *Validity and issuance.***

a. A minor's school license is a restricted, noncommercial Class C or Class M driver's license.

b. The license is valid during the times and for the purposes set forth in Iowa Code section 321.194 and at any time when the licensee is accompanied in accordance with Iowa Code section 321.180B(1).

c. The type of motor vehicle that may be operated is controlled by the class of driver's license issued, except that Iowa Code section 321.194 as amended by 2021 Iowa Acts, Senate File 231, section 1, prohibits a licensee from operating a motor vehicle with more than two axles or a motor vehicle towing another vehicle. A Class C minor's school license is valid for operating a motorcycle only if the license has a motorcycle endorsement. A minor's school license is valid for operating a motorized bicycle.

d. The license is issued for two years.

##### **602.26(2) *Requirements.***

a. An applicant shall be at least 14 years of age but not yet 18 and meet the requirements of Iowa Code section 321.194.

b. An applicant who attends a public school shall submit a statement of necessity signed by the chairperson of the school board, the superintendent of the school, or the principal of the school if authorized by the superintendent. An applicant who attends an accredited nonpublic school shall submit a statement of necessity signed by an authority in charge of the accredited nonpublic school or a duly authorized representative of the authority. The statement shall be on Form 430021. The requirements of this paragraph apply to any applicant seeking to use the license for the purposes set forth in Iowa Code section 321.194(2) "a" as amended by 2021 Iowa Acts, Senate File 231, section 2.

c. An applicant shall submit proof of successful completion of an Iowa-approved course in driver education.

d. For a Class M minor's school license or a motorcycle endorsement, an applicant shall also submit proof of successful completion of an Iowa-approved course in motorcycle rider education.

##### **602.26(3) *Exemption.***

a. An applicant is not required to have completed an approved driver education course if the applicant demonstrates to the satisfaction of the department that completion of the course would impose a hardship upon the applicant; however, the applicant must meet all other requirements for a school license. "Hardship" means:

(1) If the applicant is 14 years old, that a driver education course will not begin at the applicant's school(s) of enrollment or at a public school in the applicant's district of residence within one year following the applicant's fourteenth birthday; or

(2) If the applicant is 15 years old, that a driver education course will not begin at the applicant's school(s) of enrollment or at a public school in the applicant's district of residence within six months following the applicant's fifteenth birthday; or

(3) If the applicant is between 16 and 18 years old, that a driver education course is not offered at the applicant's school(s) of enrollment or at a public school in the applicant's district of residence at the time the request for hardship status is submitted to the department; or

(4) That the applicant is a person with a disability. In this rule, "person with a disability" means that, because of a disability or impairment, the applicant is unable to walk in excess of 200 feet unassisted or cannot walk without causing serious detriment or injury to the applicant's health.

b. "Demonstrates to the satisfaction of the department" means that the department has received written proof that a hardship exists. An applicant who attends a public school shall submit written proof of hardship signed by the applicant's parent, custodian or guardian and by the superintendent, the chairperson of the school board, or the principal, if authorized by the superintendent, of the applicant's school or school district of residence. An applicant who attends an accredited nonpublic school shall submit written proof of hardship signed by the applicant's parent, custodian or guardian and by either an authority in charge of the accredited nonpublic school or a duly authorized representative of the authority, or by the superintendent, the chairperson of the school board, or the principal, if authorized by the superintendent, of the applicant's school district of residence.

##### **602.26(4) *Multiple residences.***

*a.* An applicant whose parents are divorced or separated and who as a result of shared custody maintains more than one residence may be authorized to operate a motor vehicle from either residence during the times and for the purposes set forth in Iowa Code section 321.194 if one of the following applies:

(1) If the applicant attends a public school, the statement of necessity provided to the department certifies that a need exists to drive from each residence, that the school of enrollment identified in the statement of necessity meets the geographic requirements for an applicant attending a public school set forth in Iowa Code section 321.194 as determined by the primary residence identified in the statement of necessity, and that the secondary residence identified in the statement of necessity is either within the school district that includes the applicant's school of enrollment or within an Iowa school district contiguous to the applicant's school of enrollment.

(2) If the applicant attends an accredited nonpublic school, the statement of necessity provided to the department certifies that a need exists to drive from each residence, that the school of enrollment identified in the statement of necessity meets the geographic requirements for an applicant attending an accredited nonpublic school set forth in Iowa Code section 321.194 as determined by the primary residence identified in the statement of necessity, and that the secondary residence identified in the statement of necessity is no more than 50 miles driving distance from the school of enrollment.

*b.* The fact that either residence is less than one mile from the applicant's school of enrollment shall not preclude travel to and from each residence at the times and for the purposes set forth in Iowa Code section 321.194 provided that need is otherwise demonstrated.

*c.* A minor's school license approved for travel to and from two residences for the purposes set forth in Iowa Code section 321.194 shall not be valid for travel directly between each residence unless the licensee is accompanied in accordance with Iowa Code section 321.180B(1) or unless the travel is for the purposes set forth in and subject to the limitations of Iowa Code section 321.194(2) "a" as amended by 2021 Iowa Acts, Senate File 231, section 2.

*d.* The primary residential address listed in the statement of necessity shall appear on the face of the license. A minor's school license approved for travel to and from two residences shall include a "J" restriction on the face of the license, and the secondary address listed in the statement of necessity shall be listed on the reverse side of the license as part of the "J" restriction, with the following notation: "Also valid to drive to and from [secondary residential address] in compliance with 321.194."

This rule is intended to implement Iowa Code sections 321.177, 321.180B, 321.189, 321.194 as amended by 2021 Iowa Acts, Senate File 231, and 321.196.

[ARC 2644C, IAB 8/3/16, effective 9/7/16; ARC 4271C, IAB 1/30/19, effective 3/6/19; ARC 4759C, IAB 11/6/19, effective 12/11/19; ARC 5258C, IAB 11/4/20, effective 12/9/20; ARC 5942C, IAB 10/6/21, effective 11/10/21]

[Filed 1/20/88, Notice 12/2/87—published 2/10/88, effective 3/16/88]

[Filed 11/3/88, Notice 9/21/88—published 11/30/88, effective 1/4/89]

[Filed emergency 6/29/89—published 7/26/89, effective 7/31/89]

[Filed 9/21/89, Notice 7/26/89—published 10/18/89, effective 11/22/89]

[Filed 11/1/89, Notice 7/26/89—published 11/29/89, effective 1/3/90]

[Filed emergency 11/30/89—published 12/27/89, effective 12/1/89]

[Filed emergency 6/7/90—published 6/27/90, effective 7/1/90]

[Filed 12/18/91, Notice 11/13/91—published 1/8/92, effective 2/12/92]

[Filed 10/30/96, Notice 9/25/96—published 11/20/96, effective 12/25/96]

[Filed 10/28/98, Notice 9/23/98—published 11/18/98, effective 12/23/98]

[Filed emergency 7/20/00 after Notice 6/14/00—published 8/9/00, effective 7/24/00]

[Filed 6/19/02, Notice 4/17/02—published 7/10/02, effective 8/14/02]

[Filed 10/11/06, Notice 8/30/06—published 11/8/06, effective 12/13/06]

[Filed ARC 7902B (Notice ARC 7721B, IAB 4/22/09), IAB 7/1/09, effective 8/5/09]

[Filed ARC 1714C (Notice ARC 1601C, IAB 9/3/14), IAB 11/12/14, effective 12/17/14]

[Filed Emergency ARC 2071C, IAB 8/5/15, effective 7/14/15]

[Filed ARC 2337C (Notice ARC 2070C, IAB 8/5/15), IAB 1/6/16, effective 2/10/16]

[Filed ARC 2644C (Notice ARC 2544C, IAB 5/25/16), IAB 8/3/16, effective 9/7/16]

[Filed ARC 2985C (Notice ARC 2908C, IAB 1/18/17), IAB 3/15/17, effective 4/19/17]

[Filed ARC 4271C (Notice ARC 4161C, IAB 12/5/18), IAB 1/30/19, effective 3/6/19]

[Filed ARC 4586C (Notice ARC 4476C, IAB 6/5/19), IAB 7/31/19, effective 9/4/19]

[Filed ARC 4759C (Notice ARC 4624C, IAB 8/28/19), IAB 11/6/19, effective 12/11/19]

[Filed ARC 4851C (Notice ARC 4715C, IAB 10/23/19), IAB 1/1/20, effective 2/5/20]

[Filed ARC 5204C (Notice ARC 5102C, IAB 7/29/20), IAB 10/7/20, effective 11/11/20]

[Filed ARC 5258C (Notice ARC 5154C, IAB 8/26/20), IAB 11/4/20, effective 12/9/20]  
[Filed ARC 5495C (Notice ARC 5384C, IAB 1/13/21), IAB 3/10/21, effective 4/14/21]  
[Filed ARC 5942C (Notice ARC 5804C, IAB 7/28/21), IAB 10/6/21, effective 11/10/21]  
[Editorial change: IAC Supplement 12/28/22]

<sup>1</sup> Effective date delayed 70 days by the Administrative Rules Review Committee at its March 9, 1988, meeting. Delay lifted by ARRC, April 21, 1988.

CHAPTER 603  
Reserved



CHAPTER 604  
LICENSE EXAMINATION

[Prior to 6/3/87, see Transportation Department[820]—(07,C)rules 13.3 and 13.17]

**761—604.1(321) Authority and scope.**

**604.1(1)** The department is authorized to determine by examination an applicant's ability to operate motor vehicles safely upon the highways and to issue all driver's licenses.

**604.1(2)** This chapter of rules shall apply to the examination for all driver's licenses. Information on the additional examination procedures and requirements for a commercial driver's license or commercial learner's permit is given in 761—Chapter 607.

This rule is intended to implement Iowa Code sections 321.2, 321.3, 321.13, 321.177, and 321.186.

[ARC 2071C, IAB 8/5/15, effective 7/14/15; ARC 2337C, IAB 1/6/16, effective 2/10/16]

**761—604.2(321) Definitions.**

*"Binocular field of vision"* is the sum of the temporal measurements or the sum of the nasal measurements.

*"Monocular field of vision"* is the sum of the temporal measurement and the nasal measurement for one eye.

*"Representative vehicle"* is a vehicle which is characteristic of and requires operating skills comparable to those vehicles that may legally be operated under the class of license or endorsement desired.

This rule is intended to implement Iowa Code sections 321.174 and 321.186.

[ARC 9991B, IAB 2/8/12, effective 3/14/12]

**761—604.3(17A) Information and forms.**

**604.3(1)** Applications, forms, and information about driver's license examinations are available at any driver's license service center. Assistance is also available from the motor vehicle division by mail at Motor Vehicle Division, Iowa Department of Transportation, P.O. Box 9204, Des Moines, Iowa 50306-9204; in person at 6310 SE Convenience Blvd., Ankeny, Iowa; by telephone at (515)244-8725; by facsimile at (515)239-1837; or on the department's website at [www.iowadot.gov](http://www.iowadot.gov).

**604.3(2)** The "Iowa Driver Manual" and the "Iowa Motorcycle Operator Manual" are also available from the department and on the department's website at [www.iowadot.gov](http://www.iowadot.gov).

This rule is intended to implement Iowa Code section 17A.3.

[ARC 5048C, IAB 6/3/20, effective 7/8/20; Editorial change: IAC Supplement 12/28/22]

**761—604.4 to 604.6** Reserved.

**761—604.7(321) Examination.**

**604.7(1)** An examination shall include:

- a. A vision screening if the person has not filed a vision report.
- b. A knowledge test of Iowa traffic laws and highway signs.
- c. A driving test of the person's ability to operate a motor vehicle.

**604.7(2)** The examination required for a driver's license depends upon the class of license requested, applicable endorsements, and the qualifications of the applicant.

This rule is intended to implement Iowa Code sections 321.186 and 321.186A.

**761—604.8 and 604.9** Reserved.

**761—604.10(321) Vision screening.**

**604.10(1) Requirement.** Vision screening or a vision report is required of an applicant for a driver's license.

**604.10(2) Method.** At driver's license service centers, a vision screening instrument shall be used to screen the applicant's vision. An applicant who has corrective lenses may be screened with or without the corrective lenses.

**604.10(3) Report.** A vision report shall be submitted on Form 430032 signed by a licensed vision specialist and shall report the person's visual acuity level and field of vision as measured within 30 days prior to the date of the application. In lieu of Form 430032, a vision report signed by a licensed vision specialist on the specialist's letterhead may be accepted if it contains all the information specified on Form 430032.

**604.10(4) Exception for persons renewing electronically.** An applicant renewing a driver's license electronically pursuant to 761—subrule 605.25(7) is not required to complete a vision screen or submit a vision report to complete the renewal. This subrule does not preclude the department from requiring a vision screen or vision report of a person

who has renewed a driver's license electronically when the department has reason to believe that the person is not capable of operating a motor vehicle safely.

This rule is intended to implement Iowa Code sections 321.186, 321.186A and 321.196.

[ARC 9991B, IAB 2/8/12, effective 3/14/12; ARC 0895C, IAB 8/7/13, effective 7/9/13; ARC 1073C, IAB 10/2/13, effective 11/6/13; ARC 5048C, IAB 6/3/20, effective 7/8/20]

**761—604.11(321) Vision standards.** The visual acuity and field of vision standards for licensing and the applicable restrictions are as follows.

**604.11(1) Visual acuity standards.**

*a. When the applicant is screened without corrective lenses.* If the visual acuity is 20/40 or better with both eyes or with the better eye, no restriction will be imposed. If the visual acuity is less than 20/40 but at least 20/70 with both eyes or with the better eye, the applicant shall be restricted from driving when headlights are required.

*b. When the applicant is screened with corrective lenses.* If the visual acuity is 20/40 or better with both eyes or with the better eye, the applicant shall be required to wear corrective lenses. If the visual acuity is less than 20/40 but at least 20/70 with both eyes or with the better eye, the applicant shall be required to wear corrective lenses and shall be restricted from driving when headlights are required.

*c. Other standards.* If the visual acuity in the left eye is less than 20/100, the applicant shall be restricted to driving a vehicle with both left and right outside rearview mirrors. However, if the applicant has a visual acuity of 20/40 in the right eye and less than 20/100 in the left eye without corrective lenses and has corrective lenses that improve the vision in the left eye to better than 20/100, the applicant shall have the option of being restricted to driving with corrective lenses or driving a vehicle with both left and right outside rearview mirrors.

**604.11(2) Field of vision standards.**

*a.* If the binocular field of vision is at least 140 degrees, no restriction will be imposed.

*b.* If the binocular field of vision is less than 140 degrees but at least 110 degrees, or one eye has a monocular field of vision of at least 100 degrees, the applicant shall be restricted to driving a vehicle with both left and right outside rearview mirrors.

This rule is intended to implement Iowa Code sections 321.186, 321.193, and 321.196.

[ARC 9991B, IAB 2/8/12, effective 3/14/12]

**761—604.12(321) Vision referrals.**

**604.12(1) Referral.**

*a.* If during any vision screening, an applicant cannot attain 20/40 with at least one eye but can attain 20/70 with at least one eye, the department shall not issue a license to the applicant. Instead, the department shall advise the applicant to consult a licensed vision specialist.

*b.* A vision report, pursuant to subrule 604.10(3), shall be required before the department will reconsider licensing.

**604.12(2) License.** If the applicant's license is valid, the department may issue a temporary driving permit with restrictions appropriate to the applicant's visual acuity level and field of vision. If the applicant's license is valid for less than 30 days, the temporary driving permit shall not be valid for more than 60 days from the end of the current license validity.

**604.12(3) Report.** If the vision report recommends a restriction, the department shall issue a restricted license even though it would not be required by departmental standards.

**604.12(4) Applicant refusal.** If an applicant refuses to consult a licensed vision specialist, the department shall issue or deny the license based on the results achieved on the vision screening.

This rule is intended to implement Iowa Code sections 321.181, 321.186, 321.186A, 321.193 and 321.196.

[ARC 5048C, IAB 6/3/20, effective 7/8/20]

**761—604.13(321) Vision screening results.**

**604.13(1) Two-year license.** An applicant who cannot attain a visual acuity of 20/40 with both eyes or with the better eye shall be issued a two-year license.

**604.13(2) License denied.**

*a.* An applicant who cannot attain a visual acuity of 20/70 with both eyes or with the better eye shall not be licensed, subject to discretionary issuance under subrule 604.13(4).

*b.* If the applicant's binocular field of vision is less than 110 degrees, or the monocular field of vision is less than 100 degrees, the applicant shall not be licensed, subject to discretionary issuance under subrule 604.13(4).

**604.13(3) Reapplication.** An applicant who cannot meet the vision standards in subrule 604.13(2) may reapply when the vision improves and the applicant meets the vision standards. If a suspension or denial notice was served,

reapplication must be made to the motor vehicle division at the address in subrule 604.3(1), or at a driver's license service center.

**604.13(4) Discretionary issuance.**

*a.* An applicant whose license is restricted under rule 761—604.11(321) or who cannot meet the vision standards in subrule 604.13(2) may submit a written request for review by an informal settlement officer.

*b.* Based upon consideration of the applicant's vision report, driving test and driving record, the written recommendation of the applicant's licensed vision specialist, and traffic conditions in the vicinity of the applicant's residence, the officer may recommend issuing a license with restrictions suitable to the applicant's capabilities. However:

(1) An applicant who cannot attain a visual acuity of 20/100 with both eyes or with the better eye may be considered for licensing only after recommendation by the medical advisory board.

(2) An applicant who cannot attain a visual acuity of 20/199 with both eyes or with the better eye shall not be licensed.

(3) If an applicant's binocular field of vision or monocular field of vision is less than 75 degrees, the applicant may be considered for licensing only after recommendation by the medical advisory board.

(4) An applicant who cannot attain a binocular or monocular field of vision of 21 degrees shall not be licensed.

*c.* The officer's recommendation denying discretionary issuance or regarding the extent and nature of restrictions is subject to reversal or modification upon review or appeal only if it is clearly characterized by an abuse of discretion.

This rule is intended to implement Iowa Code sections 321.186, 321.186A, 321.193 and 321.196.

[ARC 9991B, IAB 2/8/12, effective 3/14/12; ARC 5048C, IAB 6/3/20, effective 7/8/20; Editorial change: IAC Supplement 12/28/22]

**761—604.14 to 604.19** Reserved.

**761—604.20(321) Knowledge test.**

**604.20(1) Written test.** A knowledge test is a written test to determine an applicant's ability to read and understand Iowa traffic laws and the highway signs that regulate, warn, and direct traffic. A test may be revised at any time but each test states the minimum passing score.

**604.20(2) Three types of tests.** There are three types of knowledge tests: an operator's test, a chauffeur's test, and a motorcycle test. The requirement for a license depends upon the class of license desired, applicable endorsements, and the qualifications of the applicant.

**604.20(3) Oral test.** An applicant who is unable to read or understand a written test may request an oral test. The oral test may be administered by an examiner or by an automated testing device.

**604.20(4) Test score.** The test score result is valid for 180 days.

**604.20(5) Retesting.** An applicant who fails a knowledge test may repeat the test at the discretion of the examiner.

This rule is intended to implement Iowa Code section 321.186.

[ARC 5048C, IAB 6/3/20, effective 7/8/20; ARC 6059C, IAB 12/1/21, effective 1/5/22]

**761—604.21(321) Knowledge test requirements and waivers.**

**604.21(1) Knowledge test requirements.** The knowledge test requirements are as follows:

*a. Operator's test.* An operator's knowledge test is required for all classes of driver's licenses and all types of special driver's licenses and permits.

*b. Motorcycle test.* A motorcycle knowledge test is required for all:

- (1) Motorcycle instruction permits.
- (2) Class M driver's licenses.
- (3) Motorcycle endorsements.

*c. Chauffeur's test.* A chauffeur's knowledge test is required for all chauffeur's instruction permits.

**604.21(2) Knowledge test waivers.** The department may waive a knowledge test listed in subrule 604.21(1) if the applicant meets one of the following qualifications:

*a.* The applicant has passed the same type of test for another Iowa driver's license or an equivalent out-of-state license that is still valid or has expired within the past year.

*b.* The applicant has a valid, equivalent driver's license issued by a foreign jurisdiction with which Iowa has a nonbinding reciprocity agreement.

*c.* The applicant has a military extension and is renewing the applicant's Iowa driver's license within six months following separation from active duty.

*d.* The applicant is renewing an Iowa driver's license or endorsement within a period of one year after the expiration date of the license or endorsement.

*e.* The applicant is reinstating from a denial, cancellation, suspension, revocation, disqualification or bar of an Iowa driver's license or endorsement within a period of one year after the expiration date of the denial, cancellation, suspension, revocation, disqualification or bar.

This rule is intended to implement Iowa Code sections 321.1(8) as amended by 2021 Iowa Acts, House File 389, 321.180, 321.180A, 321.180B, 321.186, 321.189, 321.196 and 321.198.

[ARC 5048C, IAB 6/3/20, effective 7/8/20; ARC 5942C, IAB 10/6/21, effective 11/10/21]

**761—604.22(321) Knowledge test results.** Rescinded ARC 5048C, IAB 6/3/20, effective 7/8/20.

**761—604.23 to 604.29** Reserved.

**761—604.30(321) Driving test.** A driving test is a demonstration of an applicant's ability to exercise ordinary and reasonable control in the operation of a motor vehicle under actual traffic conditions. The test is also called a road test, field test, or driving demonstration. A motorcycle skill test is an off-street demonstration of an applicant's ability to control the motorcycle in a set of standard maneuvers, and a motorcycle driving test is an on-street demonstration.

**604.30(1) Vehicle type and safety.**

*a.* For the driving test, the applicant shall provide a representative vehicle as defined in 761—604.2(321) and proof of financial responsibility for the representative vehicle.

*b.* The examiner or other authorized personnel shall visually inspect the vehicle. If a vehicle is illegal or unsafe, or is not a representative vehicle, the examiner shall refuse to administer the test until corrections are made or an acceptable vehicle is provided.

**604.30(2) Criteria and route.** Form 430024, "Your Driving Test," explains the criteria for passing the test and shall be given to the applicant before any required test, except a motorcycle skill test. The applicant shall be directed over one of the routes which have been preselected by the examiner to test driving skills and maneuvers.

**604.30(3) Test score.** The examiner shall use the standard departmental score sheet and shall enter the test score and the licensing decision in the spaces provided. At the end of the test, the examiner shall explain the test score. The test score result is valid for 180 days.

**604.30(4) Retesting.** An applicant who fails a driving test may repeat the test at the discretion of the examiner.

This rule is intended to implement Iowa Code sections 321.174 and 321.186.

[ARC 9991B, IAB 2/8/12, effective 3/14/12; ARC 5048C, IAB 6/3/20, effective 7/8/20; ARC 6059C, IAB 12/1/21, effective 1/5/22]

**761—604.31(321) Driving test requirements and waivers for noncommercial driver's licenses.**

**604.31(1) Driving test requirements.** The driving test requirements for noncommercial driver's licenses are as follows:

*a. Instruction permits.* A driving test is not required to obtain an instruction permit.

*b. Class C driver's licenses.* For a Class C driver's license other than an instruction permit or a motorized bicycle license, an operator's driving test in a representative vehicle is required, except that an autocycle as defined in Iowa Code section 321.1 shall not be used for the driving test.

*c. Class D driver's licenses.* For a Class D driver's license, a driving test in a representative vehicle for the endorsement requested, as set out in 761—subrule 605.7(3), is required.

*d. Class M driver's licenses and motorcycle endorsements.* The driving test for a Class M driver's license or motorcycle endorsement consists of two parts: an off-street motorcycle skill test and an on-street driving test.

(1) The off-street motorcycle skill test is required. The on-street motorcycle driving test is also required if the applicant does not have another driver's license that permits unaccompanied driving. Neither motorcycle test is required for the purposes of operating an autocycle.

(2) A motorcycle shall be used for these tests. If a three-wheeled motorcycle is used, the driver's license shall be restricted: "Not valid for 2-wheel vehicle." An autocycle is not considered a motorcycle or a three-wheeled motorcycle for testing purposes.

*e. Motorized bicycle licenses.* For a motorized bicycle license, an off-street or on-street driving test may be required. A motorized bicycle shall be used for the test.

**604.31(2) Driving test waivers.** The department may waive a required driving test listed in subrule 604.31(1) if the applicant meets one of the following qualifications:

*a.* The applicant has successfully completed the appropriate Iowa-approved course or courses. The appropriate Iowa-approved courses are the following: driver education, other than driver education by a teaching parent under rule

761—634.11(321), for an applicant's first Class C driver's license that permits unaccompanied driving other than motorized bicycle; motorcycle rider education for a Class M driver's license or motorcycle endorsement; and motorized bicycle education for a motorized bicycle license. However, if an applicant is under the age of 18, a driving test is required if so requested by the applicant's parent, guardian, or instructor.

*b.* The applicant is renewing a Class C, Class D or Class M Iowa driver's license or endorsement within a period of one year after the expiration date of the license or endorsement.

*c.* The applicant is reinstating from a denial, cancellation, suspension, revocation, disqualification or bar of an Iowa driver's license or endorsement within a period of one year after the expiration date of the denial, cancellation, suspension, revocation, disqualification or bar.

*d.* The applicant has passed the same type of driving test for another Iowa driver's license or endorsement that is still valid or has expired within the past year.

*e.* The applicant has a military extension and is renewing the applicant's Iowa driver's license within six months following separation from active duty.

*f.* The applicant is applying for a Class C Iowa driver's license that permits unaccompanied driving and has an equivalent out-of-state license that is valid or has expired within the past year.

*g.* The applicant is applying for a Class D Iowa driver's license and has an equivalent out-of-state license that is valid or has expired within the past year.

*h.* The applicant is applying for a Class M driver's license or a motorcycle endorsement and has an equivalent out-of-state Class M driver's license or motorcycle endorsement that is valid or has expired within the past year.

*i.* The applicant has a valid, equivalent driver's license issued by a foreign jurisdiction with which Iowa has a nonbinding reciprocity agreement.

This rule is intended to implement Iowa Code sections 321.1, 321.174, 321.178, 321.178A, 321.180, 321.180A, 321.180B, 321.186, 321.189, 321.193, 321.196 and 321.198.

[ARC 7902B, IAB 7/1/09, effective 8/5/09; ARC 1612C, IAB 9/3/14, effective 10/8/14; ARC 2071C, IAB 8/5/15, effective 7/14/15; ARC 2337C, IAB 1/6/16, effective 2/10/16; ARC 2985C, IAB 3/15/17, effective 4/19/17; ARC 4586C, IAB 7/31/19, effective 9/4/19; ARC 5048C, IAB 6/3/20, effective 7/8/20]

**761—604.32 to 604.34** Reserved.

**761—604.35(321) Determination of gross vehicle weight rating.** For a vehicle that has no legible manufacturer's certification label, the applicant may provide documentation of the gross vehicle weight rating, such as a manufacturer's certificate of origin, a title, a vehicle registration document, or the vehicle identification number information for the vehicle. In the absence of the above documentation, the registered weight of the vehicle shall be presumed to be the gross vehicle weight rating.

This rule is intended to implement Iowa Code section 321.1.

**761—604.36 to 604.39** Reserved.

**761—604.40(321) Failure to pass examination.**

**604.40(1)** An applicant who fails to pass a required examination or reexamination shall not be licensed.

*a.* If the applicant does not have a valid Iowa license, the department shall deny the applicant a license.

*b.* If the applicant has a valid Iowa license, the department shall suspend the license for incapability. However, if the applicant's license is valid for less than 30 days, the department shall deny further licensing. The department shall serve a notice of suspension or denial.

*c.* See 761—615.4(321) for further information on denials and 761—615.14(321) for further information on suspensions for incapability.

*d.* An applicant may contest a denial or suspension in accordance with 761—615.38(321).

**604.40(2)** Limitations on the hearing and appeal process.

*a.* After a suspension or denial for failure to pass a required knowledge or driving test, a person who contests the suspension or denial shall be deemed to have exhausted the person's administrative remedies after three unsuccessful attempts to pass the required test.

*b.* After the three unsuccessful attempts, no further testing shall be allowed until six months have elapsed from the date of the last test failure, and then only if the applicant demonstrates a significant change or improvement in those physical or mental factors that resulted in the original decision. A request for further testing must be submitted in writing to the motor vehicle division at the address in subrule 604.3(1).

*c.* Notwithstanding paragraphs "a" and "b" of this subrule, no testing shall occur if the director determines that it is unsafe to allow testing.

This rule is intended to implement Iowa Code chapter 17A and sections 321.177, 321.180A and 321.210.  
[ARC 5048C, IAB 6/3/20, effective 7/8/20; Editorial change: IAC Supplement 12/28/22]

**761—604.41 to 604.44** Reserved.

**761—604.45(321) Reinstatement.** A person whose license has been suspended or denied for failure to pass a required examination or reexamination shall meet the vision standards for licensing, pass the required knowledge examination(s), and pass the required driving test(s) before an Iowa license will be issued.

This rule is intended to implement Iowa Code sections 321.177 and 321.186.

**761—604.46 to 604.49** Reserved.

**761—604.50(321) Special reexaminations.**

**604.50(1)** As provided in Iowa Code section 321.186, the department may require a special reexamination of any licensee. The reexamination may consist of one or more of the following:

- a. Medical report.
- b. Vision report.
- c. Vision screening.
- d. Cognitive screening.
- e. Knowledge test.
- f. Driving test.

**604.50(2)** The department may require a special reexamination when a licensee has been involved in a fatal motor vehicle accident and the investigating officer's report of the accident indicates the licensee contributed to the accident.

**604.50(3)** The department may require a special reexamination when a licensee has been involved in two accidents within a three-year period and the investigating officer's report of each accident lists one of the following "Driver/Vehicle Related Contributing Circumstances" for the licensee:

- a. Ran traffic signal.
- b. Ran stop sign.
- c. Passing, interfered with other vehicle.
- d. Left of center, not passing.
- e. Failure to yield right-of-way at uncontrolled intersection.
- f. Failure to yield right-of-way from stop sign.
- g. Failure to yield right-of-way from yield sign.
- h. Failure to yield right-of-way making left turn.
- i. Failure to yield right-of-way to pedestrian.
- j. Failure to have control.

**604.50(4)** The department may require a special reexamination when a licensee has been involved in an accident and the investigating officer's report lists a driver condition for the licensee of "fatigue or asleep."

**604.50(5)** The department may require a special reexamination when a licensee who is 65 years of age or older has been involved in an accident and information in the investigating officer's or the person's own report of the accident indicates the need for reexamination. A circumstance that may indicate a need for reexamination includes, but is not limited to, any one of the following:

- a. The licensee made a left turn that resulted in the accident.
- b. The licensee failed to yield the right-of-way at a stop sign.
- c. The licensee failed to yield the right-of-way at a yield sign.
- d. The licensee failed to yield the right-of-way at an uncontrolled intersection.
- e. The licensee failed to yield the right-of-way at a traffic control signal.
- f. The licensee's vision may be a contributing factor to an accident.
- g. The licensee has a physical disability-related license restriction other than "corrective lenses" and the accident involved one of the circumstances listed in paragraphs "a" to "f" above.
- h. The investigating officer's report lists a driver condition for the licensee of "loss of consciousness."
- i. The investigating officer's report lists a driver condition for the licensee of "illness which resulted in the accident."

**604.50(6)** The department may require a special reexamination when the department receives an accident report or a recommendation by a peace officer, a court, or a properly documented citizen's request. A factor that may indicate a need for reexamination includes, but is not limited to, any one of the following:

- a. Loss of consciousness.
- b. Confusion, disorientation or dementia.
- c. Inability to maintain a vehicle in the proper lane.
- d. Repeatedly ignoring traffic control devices in a nonchase setting.
- e. Inability to interact safely with other vehicles.
- f. Inability to maintain consistent speed when no reaction to other vehicles or pedestrians is required.
- g. Illness which resulted in an accident.

This rule is intended to implement Iowa Code sections 321.177, 321.186 and 321.210.

[ARC 5048C, IAB 6/3/20, effective 7/8/20; ARC 5495C, IAB 3/10/21, effective 4/14/21]

[Filed 7/1/75]

[Filed 12/28/76, Notice 11/3/76—published 1/12/77, effective 2/16/77]

[Filed 8/25/80, Notice 7/9/80—published 9/17/80, effective 10/22/80]

[Filed 5/11/87, Notice 3/11/87—published 6/3/87, effective 7/8/87]<sup>1</sup>

[Filed 1/20/88, Notice 12/2/87—published 2/10/88, effective 3/16/88]

[Filed emergency 11/30/89—published 12/27/89, effective 12/1/89]

[Filed emergency 6/7/90—published 6/27/90, effective 7/1/90]

[Filed 12/18/91, Notice 11/13/91—published 1/8/92, effective 2/12/92]

[Filed 11/4/93, Notice 9/29/93—published 11/24/93, effective 12/29/93]

[Filed 1/11/95, Notice 11/23/94—published 2/1/95, effective 3/8/95]

[Filed 1/21/98, Notice 12/17/97—published 2/11/98, effective 3/18/98]

[Filed 10/28/98, Notice 9/23/98—published 11/18/98, effective 12/23/98]

[Filed emergency 4/12/00 after Notice 2/23/00—published 5/3/00, effective 4/14/00]

[Filed 5/3/00, Notice 3/8/00—published 5/31/00, effective 7/5/00]

[Filed 10/11/06, Notice 8/30/06—published 11/8/06, effective 12/13/06]

[Filed ARC 7902B (Notice ARC 7721B, IAB 4/22/09), IAB 7/1/09, effective 8/5/09]

[Filed ARC 9991B (Notice ARC 9874B, IAB 11/30/11), IAB 2/8/12, effective 3/14/12]

[Filed Emergency ARC 0895C, IAB 8/7/13, effective 7/9/13]

[Filed ARC 1073C (Notice ARC 0894C, IAB 8/7/13), IAB 10/2/13, effective 11/6/13]

[Filed ARC 1612C (Notice ARC 1526C, IAB 7/9/14), IAB 9/3/14, effective 10/8/14]

[Filed Emergency ARC 2071C, IAB 8/5/15, effective 7/14/15]

[Filed ARC 2337C (Notice ARC 2070C, IAB 8/5/15), IAB 1/6/16, effective 2/10/16]

[Filed ARC 2985C (Notice ARC 2908C, IAB 1/18/17), IAB 3/15/17, effective 4/19/17]

[Filed ARC 4586C (Notice ARC 4476C, IAB 6/5/19), IAB 7/31/19, effective 9/4/19]

[Filed ARC 5048C (Notice ARC 4995C, IAB 3/25/20), IAB 6/3/20, effective 7/8/20]

[Filed ARC 5495C (Notice ARC 5384C, IAB 1/13/21), IAB 3/10/21, effective 4/14/21]

[Filed ARC 5942C (Notice ARC 5804C, IAB 7/28/21), IAB 10/6/21, effective 11/10/21]

[Filed ARC 6059C (Notice ARC 5924C, IAB 9/22/21), IAB 12/1/21, effective 1/5/22]

[Editorial change: IAC Supplement 12/28/22]

<sup>1</sup> Effective date of 604.11(2) and 604.13(2) "b" delayed until adjournment of the 1988 Session of the General Assembly pursuant to Iowa Code section 17A.8(9) by the Administrative Rules Review Committee at its June 1987 meeting.



CHAPTER 605  
LICENSE ISSUANCE

**761—605.1(321) Scope.** This chapter of rules applies to the issuance of all Iowa driver's licenses. Additional information on the issuance of a commercial driver's license or a commercial learner's permit is given in 761—Chapter 607.

This rule is intended to implement Iowa Code section 321.174.

[ARC 2071C, IAB 8/5/15, effective 7/14/15; ARC 2337C, IAB 1/6/16, effective 2/10/16]

**761—605.2(321) Definitions.** The definitions in Iowa Code section 321.1 and the following definitions apply to this chapter.

*“License”* means “driver's license” as defined in Iowa Code section 321.1(20A) unless the context otherwise requires.

*“Medical report”* means a report from a qualified medical professional attesting to a person's physical or mental capability to operate a motor vehicle safely. The report should be submitted on Form 430031, “Medical Report.” In lieu of Form 430031, a report signed by a qualified medical professional on the qualified medical professional's letterhead may be accepted if it contains all the information specified on Form 430031.

*“Qualified medical professional”* means a person licensed as a physician under Iowa Code chapter 148, a person licensed as an advanced registered nurse practitioner under Iowa Code chapter 152 and licensed with the board of nursing, or a person licensed as a physician assistant under Iowa Code chapter 148C, when practicing within the scope of the person's professional licensure.

This rule is intended to implement Iowa Code section 321.1.

[ARC 4586C, IAB 7/31/19, effective 9/4/19]

**761—605.3(321) Persons exempt.**

**605.3(1)** Persons listed in Iowa Code section 321.176 are exempt from driver's licensing requirements.

**605.3(2)** “Nearby” in Iowa Code section 321.176(2) shall mean a distance of not more than two miles.

This rule is intended to implement Iowa Code section 321.176.

[ARC 4586C, IAB 7/31/19, effective 9/4/19]

**761—605.4(252J,321) Persons not to be licensed.**

**605.4(1)** The department shall not knowingly issue a license to any person who is ineligible for licensing.

**605.4(2)** The department shall not knowingly license any person who is unable to operate a motor vehicle safely because of physical or mental disability until that person submits a medical report or vision report stating that the person is physically and mentally capable of operating a vehicle safely and passes the applicable examinations if required under 761—Chapter 604 or 607.

**605.4(3)** The department shall not knowingly license any person who has been specifically adjudged incompetent, pursuant to Iowa Code chapter 229, on or after January 1, 1976, including anyone admitted to a mental health facility prior to that date and not released until after, until the department receives specific adjudication that the person is competent. A medical report stating that the person is physically qualified to operate a motor vehicle safely shall also be required.

**605.4(4)** The department shall not knowingly license any person who suffers from syncope of any cause, any type of periodic or episodic loss of consciousness, or any paroxysmal disturbances of consciousness, including but not limited to epilepsy, until that person has not had an episode of loss of consciousness or loss of voluntary control for six months, and then only upon receipt of a medical report favorable toward licensing.

*a.* If a medical report indicates a pattern of only syncope, the department may license without a six-month episode-free period after favorable recommendation by the medical advisory board.

*b.* If a medical report indicates a pattern of such episodes only when the person is asleep or is sequestered for sleep, the department may license without a six-month episode-free period.

*c.* If an episode occurs when medications are withdrawn by a qualified medical professional, but the person is episode-free when placed back on medications, the department may license without a six-month episode-free period with a favorable recommendation from a neurologist.

*d.* If a medical report indicates the person experienced a single nonrecurring episode, the cause has been identified, the qualified medical professional is not treating the person for the episode or a contributing health condition, and the qualified medical professional believes the episode is unlikely to recur, the department may license without the six-month episode-free period with a favorable recommendation from a qualified medical professional. As

used in this paragraph, a “single nonrecurring episode” means an incident that is not caused by a health condition and there is no history of prior episodes or a health condition that may cause such an episode.

**605.4(5)** The department shall not license any person who must wear bioptic telescopic lenses to meet the visual acuity standard required for a license.

**605.4(6)** When a medical report is required, a license shall be issued only if the report indicates that the person is qualified to operate a motor vehicle safely. The department may submit the report to the medical advisory board for an additional opinion.

**605.4(7)** When the department receives evidence that an Iowa licensed driver has been adjudged incompetent or is not physically or mentally qualified to operate a motor vehicle safely, the department shall suspend the license for incapability, as explained in rule 761—615.14(321), or shall deny further licensing, as explained in rule 761—615.4(321).

**605.4(8)** The department shall not knowingly issue a license to a person who is the named individual on a certificate of noncompliance that has been received from the child support services, until the department receives a withdrawal of the certificate of noncompliance or unless an application has been filed pursuant to Iowa Code section 252J.9.

This rule is intended to implement Iowa Code sections 252J.8, 252J.9, 321.13, 321.177, 321.186, 321.193, 321.210, and 321.212.

[ARC 4586C, IAB 7/31/19, effective 9/4/19; ARC 6969C, IAB 4/5/23, effective 5/10/23; Editorial change: IAC Supplement 11/29/23]

**761—605.5(321) Contents of license.** In addition to the information specified in Iowa Code section 321.189(2), the following information shall be shown on a driver’s license.

**605.5(1) Name.** The licensee’s full legal name shall be listed as established according to 761—subrule 601.5(1) and 761—subrule 601.5(5) and shall conform to the requirements of 761—subrule 601.1(2).

**605.5(2) Current residential address.** The licensee’s current residential address shall be listed as established according to the requirements of 761—subrule 601.1(6) and 761—subrule 601.5(3).

**605.5(3) Physical description.** The physical description of the licensee on the face of the driver’s license shall include the following as established according to the requirements of 761—subrule 601.1(5):

*a.* The licensee’s eye color using these abbreviations: Blk-black, Blu-blue, Bro-brown, Dic-dichromatic, Gry-gray, Grn-green, Haz-hazel, Pnk-pink and Unk-unknown.

*b.* The licensee’s height in feet and inches.

**605.5(4) Date of birth.** The licensee’s date of birth shall be listed as established according to 761—subrule 601.5(1) and 761—subrule 601.5(6).

**605.5(5) Sex.** The licensee’s sex designation shall be listed as established according to the requirements of 761—subrule 601.5(7).

**605.5(6) REAL ID markings.**

*a.* A driver’s license that is issued as a REAL ID license as defined in 761—601.7(321) shall include a security marking as required by 6 CFR 37.17(n).

*b.* A driver’s license that is not issued as a REAL ID license as defined in 761—601.7(321) may be marked as required by 6 CFR 37.71 and any subsequent guidance issued by the U.S. Department of Homeland Security.

*c.* A driver’s license issued to a foreign national with temporary lawful status shall include the following statement on the face of the license: “limited term.”

**605.5(7) Voluntary markings.** Upon the request of the licensee, the department shall indicate on the driver’s license any of the following:

*a.* The presence of a medical condition.

*b.* That the licensee is a donor under the uniform anatomical gift law.

*c.* That the licensee has in effect a medical advance directive.

*d.* That the licensee is hard of hearing or deaf.

*e.* That the licensee is a veteran.

(1) To be eligible for a veteran designation, the licensee must be an honorably discharged veteran of the armed forces of the United States, the national guard or reserve forces. A licensee who requests a veteran designation shall submit Form 432035, properly completed by the licensee and a designee of the Iowa department of veterans affairs, or the licensee shall present certification of release or discharge from active duty, DD form 214, to the department indicating that the licensee was honorably discharged from active duty. A licensee who was a member of the national guard or reserve forces and who applies directly to the department must present a DD form 214 which indicates that the licensee was honorably discharged after serving for at least a minimum aggregate (total) of 90 days of active duty service for purposes other than training. A licensee who was a member of the national guard or reserve forces and who

has a discharge document other than a DD form 214 must have the licensee's eligibility for a veteran designation determined by a designee of the Iowa department of veterans affairs and shall apply to the department for a veteran designation by submitting Form 432035, properly completed by the licensee and a designee of the Iowa department of veterans affairs.

(2) The department may consult with and defer to the Iowa department of veterans affairs regarding what constitutes a properly completed DD form 214 and veteran status in general.

(3) If the department denies issuance of a license with a veteran designation upon presentation of the DD form 214 to the department, the licensee may obtain a license with a veteran designation if the licensee submits Form 432035, properly completed by the licensee and a designee of the Iowa department of veterans affairs.

(4) If the department issues a veteran designation in error or as the result of fraud on the part of the licensee, the driver's license with a veteran designation shall be canceled, and a duplicate license without the designation may be issued to the licensee. There shall be no charge to issue a duplicate license if the license was issued in error, unless the error was the result of fraud on the part of the licensee.

*f.* That the licensee has autism spectrum disorder.

This rule is intended to implement Iowa Code sections 142C.3 and 321.189, the REAL ID Act of 2005 (49 U.S.C. Section 30301 note), and 6 CFR Part 37.

[ARC 0347C, IAB 10/3/12, effective 11/7/12; ARC 1714C, IAB 11/12/14, effective 12/17/14; ARC 2888C, IAB 1/4/17, effective 2/8/17; ARC 4000C, IAB 9/12/18, effective 10/17/18; ARC 4000C, IAB 9/12/18, effective 10/17/18; ARC 4586C, IAB 7/31/19, effective 9/4/19; ARC 5302C, IAB 12/2/20, effective 1/6/21; ARC 6969C, IAB 4/5/23, effective 5/10/23]

**761—605.6(321) License class.** The driver's license class shall be coded on the face of the driver's license using these codes:

Class A—commercial driver's license

Class B—commercial driver's license

Class C—commercial driver's license

Class C—noncommercial driver's license

Class D—noncommercial driver's license, chauffeur

Class M—noncommercial driver's license, motorcycle only

This rule is intended to implement Iowa Code section 321.189.

[ARC 0347C, IAB 10/3/12, effective 11/7/12; ARC 4586C, IAB 7/31/19, effective 9/4/19]

**761—605.7(321) Endorsements.** The endorsements shall be coded on the face of the driver's license and explained in text on the back of the driver's license.

**605.7(1)** *For a commercial driver's license.* The following endorsements may be added to a Class A, B or C commercial driver's license using these letter codes:

H—Hazardous material

P—Passenger

N—Tank

X—Hazardous material and tank

T—Double/triple trailers

S—School bus

**605.7(2)** *For a commercial learner's permit.* The following endorsements are the only endorsements that may be added to a commercial learner's permit using these letter codes. All other endorsements are prohibited on a commercial learner's permit.

P—Passenger

N—Tank

S—School bus

**605.7(3)** *For a Class D driver's license (chauffeur).* The following endorsement may be added to a Class D driver's license using this number code:

3—Passenger vehicle less than 16-passenger design

**605.7(4)** *Motorcycle endorsement.* A motorcycle endorsement may be added to any driver's license that permits unaccompanied driving, other than a Class M driver's license or a motorized bicycle license, using the following letter code:

L—Motorcycle

This rule is intended to implement Iowa Code sections 321.1(8), 321.180 and 321.189.

[ARC 2071C, IAB 8/5/15, effective 7/14/15; ARC 2337C, IAB 1/6/16, effective 2/10/16; ARC 4000C, IAB 9/12/18, effective 10/17/18; ARC 4586C, IAB 7/31/19, effective 9/4/19; ARC 5942C, IAB 10/6/21, effective 11/10/21; ARC 6969C, IAB 4/5/23, effective 5/10/23]

**761—605.8(321) Restrictions.** Restrictions shall be coded on the face of the driver's license and explained in text on the back of the driver's license. For purposes of this rule, "CMV" means commercial motor vehicle.

**605.8(1)** *For all licenses.* The following restrictions may apply to any driver's license:

- B—Corrective lenses required
- C—Mechanical aid (as detailed in the restriction on the back of the card)
- D—Prosthetic aid (as detailed in the restriction on the back of the card)
- F—Left and right outside rearview mirrors
- G—No driving when headlights required
- H—Temporary restricted license or permit (work permit)
- I—Ignition interlock required
- J—Restrictions on the back of card
- S—SR required (proof of financial responsibility for the future)
- T—Medical report required at renewal
- U—Not valid for 2-wheel vehicle
- W—Restricted commercial driver's license (CDL)
- Y—Intermediate license

**605.8(2)** *For a noncommercial driver's license.* The following restrictions apply only to a noncommercial driver's license:

- 8—Special instruction permit
- 9—Passenger restriction for intermediate license
- Q—No interstate or freeway driving

**605.8(3)** *For a commercial driver's license.* The following restrictions apply to a commercial driver's license:

- E—No manual transmission equipped CMV
- K—Intrastate only
- L—No air brake equipped CMV
- M—No Class A passenger vehicle
- N—No Class A and B passenger vehicle
- O—No tractor trailer CMV
- V—Medical variance
- Z—No full air brake equipped CMV

**605.8(4)** *For a commercial learner's permit.* The following restrictions apply to a commercial learner's permit.

- K—Intrastate only
- L—No air brake equipped CMV
- M—No Class A passenger vehicle
- N—No Class A and B passenger vehicle
- P—No passengers in CMV bus
- V—Medical variance
- X—No cargo in CMV tank vehicle

**605.8(5)** *Special licenses.* A numbered restriction will designate a special driver's license using these codes:

- 1—Motorcycle instruction permit
- 2—Noncommercial instruction permit (vehicle less than 16,001 gross vehicle weight rating)
- 3—Commercial learner's permit
- 4—Chauffeur's instruction permit
- 5—Motorized bicycle license
- 6—Minor's restricted license
- 7—Minor's school license

**605.8(6)** *Additional information.*

*a. Recall of current licensees.* Based on information disclosed by the applicant to the department, or the department's knowledge of a licensee's physical or mental condition, the department may issue a restriction requiring a person to complete additional examination or submit additional information at a specified time to retain a valid license. The department may require a medical report to be submitted. The department shall send Form 430511 as a reminder to submit the requested information or appear for examination.

*b. Loss of consciousness or voluntary control.*

(1) If a person is licensed pursuant to paragraphs 605.4(4) "a," "b," or "c," the department shall issue the first driver's license with a restriction stating: "Medical report to be furnished at the end of six months."

(2) If this medical report shows that the person has been free of an episode of loss of consciousness or voluntary control since the previous medical report and the report recommends licensing, the department shall issue a duplicate driver's license with a restriction stating: "Medical report required at renewal." At each renewal accompanied by a favorable medical report, the department shall issue a two-year driver's license with the same restriction.

(3) The department may remove the medical report requirement and issue a full-term driver's license if recommended by a qualified medical professional and if the latest medical information on file with the department indicates that either of the following are true:

1. The person has not had an episode of loss of consciousness or voluntary control and has not been prescribed medications to control such episodes during the 24-month period immediately preceding application for a license.

2. The person has not had an episode of loss of consciousness or voluntary control during the ten-year period immediately preceding application for a license.

*c. Financial responsibility.* When a person is required under Iowa Code chapter 321A to have future proof of financial responsibility on file, the license restriction will read: "SR required." The license shall be valid only for the operation of motor vehicles covered by the class of license issued and by the proof of financial responsibility filed.

*d. Vision restriction.* Restrictions relating to vision are addressed in 761—Chapter 604.

This rule is intended to implement Iowa Code chapter 321A and sections 321.177, 321.178, 321.180, 321.180A, 321.180B, 321.186, 321.188, 321.189, 321.193, 321.194, 321.215, 321J.4, and 321J.20.

[ARC 9991B, IAB 2/8/12, effective 3/14/12; ARC 0661C, IAB 4/3/13, effective 5/8/13; ARC 2071C, IAB 8/5/15, effective 7/14/15; ARC 2337C, IAB 1/6/16, effective 2/10/16; ARC 4000C, IAB 9/12/18, effective 10/17/18; ARC 4586C, IAB 7/31/19, effective 9/4/19; ARC 6969C, IAB 4/5/23, effective 5/10/23]

**761—605.9(321) License term for temporary foreign national.** A driver's license issued to a person who is a foreign national with temporary lawful status shall be issued only for the length of time the person is authorized to be present as verified by the department, not to exceed two years. However, if the person's lawful status as verified by the department has no expiration date, the driver's license shall be issued for a period of no longer than one year.

This rule is intended to implement Iowa Code section 321.196, the REAL ID Act of 2005 (49 U.S.C. Section 30301 note), and 6 CFR Part 37.

[ARC 0347C, IAB 10/3/12, effective 11/7/12; ARC 4586C, IAB 7/31/19, effective 9/4/19]

**761—605.10(321) Fees for driver's licenses.** Fees for driver's licenses are specified in Iowa Code section 321.191. A license fee may be paid by cash, check, credit card, debit card or money order.

**605.10(1)** If the payment is by check, the check shall be for the exact amount of the fee and shall be payable to: Treasurer, State of Iowa. An exception may be made when a traveler's check is presented.

**605.10(2)** One payment method may be used to pay fees for several persons, such as members of a family or employees of a business firm. One payment method may pay all fees involved, such as the license fee and the reinstatement fee.

**605.10(3)** An applicant who is on federal active duty or state active duty, a veteran with a permanent service-connected disability rating of 100 percent, or a veteran who was issued an honorable discharge or general discharge under honorable conditions is eligible for a waiver of the fees for a driver's license as provided in Iowa Code section 321.191 as amended by 2022 Iowa Acts, Senate File 2383, section 25. An eligible applicant may qualify for more than one fee waiver.

*a.* An applicant must provide proof of eligibility for the fee waiver to the department in the following ways as applicable to the applicant's active duty, veteran or disability status:

(1) An active duty service member must present an unexpired Armed Forces of the United States Geneva Conventions identification card, also known as a common access card (CAC), issued by the U.S. Department of Defense under 32 CFR Part 161. A federal or state military member who is a reservist may instead present an unexpired Uniformed Services identification card (USID) issued by the U.S. Department of Defense under 32 CFR Part 161 indicating a reserve affiliation.

(2) An applicant with a permanent service-connected disability rating of 100 percent must present proof that the applicant is the subject of a certification of disability of 100 percent from the U.S. Department of Veterans Affairs.

(3) An applicant who has been discharged from military service must present certification of release or discharge from active duty, DD form 214, indicating that the applicant received an honorable discharge or a general discharge under honorable conditions.

*b.* An applicant who qualifies for the fee waiver under subparagraph 605.10(3)"a"(2) or 604.10(3)"a"(3) or both subparagraphs is required to submit proof of eligibility only once unless the proof is invalid or not accepted by the department.

c. An applicant who qualifies for the fee waiver under subparagraph 605.10(3)“a”(2) or 604.10(3)“a”(3) or both subparagraphs, who has presented proof of eligibility to the department during a previous license issuance transaction and who is otherwise eligible under subrule 605.25(7) or 605.25(8) to renew the applicant’s driver’s license electronically, will be waived from the applicable fees during the electronic renewal. An applicant who qualifies under subparagraph 605.10(3)“a”(1) will not receive the applicable fee waivers if the applicant chooses to renew the driver’s license electronically under subrule 605.25(7) or 605.25(8).

This rule is intended to implement Iowa Code section 321.191 as amended by 2022 Iowa Acts, Senate File 2383, section 25.

[ARC 9991B, IAB 2/8/12, effective 3/14/12; ARC 4586C, IAB 7/31/19, effective 9/4/19; ARC 5302C, IAB 12/2/20, effective 1/6/21; ARC 6617C, IAB 11/2/22, effective 12/7/22]

### **761—605.11(321) Duplicate license.**

**605.11(1)** *Lost, stolen or destroyed license.* To replace a valid license that is lost, stolen or destroyed, the licensee shall provide the licensee’s full legal name, date of birth, and social security number, all of which must be verified by the department, and pay the replacement fee. A licensee subject to 761—paragraph 601.5(2)“b” shall provide the applicant’s U.S. Customs and Immigration Services number, which must be verified by the department. The department may investigate or require additional information as may be reasonably necessary to determine that the licensee’s identity matches the identity of record and shall not issue the replacement license if the licensee’s identity is questionable, cannot be determined, or otherwise does not match the identity of record. If the licensee’s current residential address, name, date of birth, or sex designation has changed since the previous license was issued, the licensee shall comply with subrule 605.11(2).

**605.11(2)** *Voluntary replacement.* The department shall issue a duplicate of a valid license to an eligible licensee if the license is surrendered to the department and the replacement fee is paid. Voluntary replacement includes but is not limited to:

- a. Replacement of a damaged license.
- b. Replacement to change the current residential address on a license. The licensee shall notify the department to establish the current residential address.
- c. Replacement to change the name on a license. The licensee shall comply with the requirements of 761—subrule 601.5(5) to establish a name change.
- d. Replacement to change the date of birth on a license. The licensee shall comply with the requirements of 761—subrule 601.5(6) to establish a change of date of birth.
- e. Replacement to change the sex designation on a license. The licensee shall comply with the requirements of 761—subrule 601.5(7) to establish a change of sex designation.
- f. Issuance of a license without the words “under 21” to a licensee who is 21 years of age or older.
- g. Issuance of a license without the words “under 18” to a licensee who is 18 years of age or older. (If the licensee is under 21 years of age, the words “under 21” will replace the words “under 18.”)
- h. Issuance of a noncommercial driver’s license to an eligible person who has been disqualified from operating a commercial motor vehicle.
- i. Replacement of a valid license before its expiration date to obtain a license that may be accepted for federal identification purposes under 6 CFR Part 37 (a REAL ID license). The licensee shall comply with the requirements of 761—601.5(321) to obtain a REAL ID license.
- j. Replacement to add a veteran designation to the license. To be eligible for a veteran designation, the licensee must comply with the requirements of paragraph 605.5(7)“e.”

**605.11(3)** *Replacement upon attaining the age of 21.* A licensee, upon attaining the age of 21, who is otherwise eligible for a driver’s license is eligible to electronically apply for a replacement driver’s license under this rule for the unexpired months of the license, regardless of whether the most recent issuance occurred electronically.

a. Except for the requirements in subparagraphs 605.25(7)“a”(1) and 605.25(7)“a”(2), the licensee must meet the eligibility requirements listed in paragraph 605.25(7)“a” or paragraph 605.25(8)“a” to replace the license electronically and must also meet the following criteria:

- (1) The licensee must be at least 21 years old.
  - (2) The licensee must currently hold a driver’s license marked “Under 21” as provided in Iowa Code section 321.189.
- b. Notwithstanding any other provision of this chapter to the contrary, the department may accept an electronic replacement application if the licensee seeks replacement of a special instruction permit or a license with a single “J” restriction accompanied by a “9” restriction.

**605.11(4)** *Fee.* The fee to replace a license is \$10.

This rule is intended to implement Iowa Code sections 321.13, 321.189, 321.195 and 321.208, the REAL ID Act of 2005 (49 U.S.C. Section 30301 note), and 6 CFR Part 37.

[ARC 7902B, IAB 7/1/09, effective 8/5/09; ARC 0347C, IAB 10/3/12, effective 11/7/12; ARC 1714C, IAB 11/12/14, effective 12/17/14; ARC 2888C, IAB 1/4/17, effective 2/8/17; ARC 3451C, IAB 11/8/17, effective 12/13/17; ARC 4000C, IAB 9/12/18, effective 10/17/18; ARC 4586C, IAB 7/31/19, effective 9/4/19; ARC 4851C, IAB 1/1/20, effective 2/5/20; ARC 6969C, IAB 4/5/23, effective 5/10/23]

#### **761—605.12(321) Address changes.**

**605.12(1)** A licensee shall notify the department of a change in the licensee's mailing address within 30 days of the change. Notice shall be given by:

a. Submitting the address change to the Motor Vehicle Division, Iowa Department of Transportation, P.O. Box 9204, Des Moines, Iowa 50306-9204, using Form 430012 or a written and signed statement listing the licensee's full name, date of birth, driver's license number and new mailing address; or

b. Completing the address change on the department's website at [www.iowadot.gov](http://www.iowadot.gov); or

c. Appearing in person to change the mailing address at any driver's license service center.

**605.12(2)** Parents or legal guardians may provide written notice of a mailing address change on behalf of their minor children.

**605.12(3)** The department may use U.S. Postal Service address information to update its address records.

This rule is intended to implement Iowa Code sections 321.182 and 321.184.

[ARC 4000C, IAB 9/12/18, effective 10/17/18; ARC 4851C, IAB 1/1/20, effective 2/5/20; ARC 6969C, IAB 4/5/23, effective 5/10/23]

#### **761—605.13 and 605.14 Reserved.**

#### **761—605.15(321) License extension.**

**605.15(1)** *Six-month extension.* An Iowa resident may apply for a noncommercial six-month extension of a license if the resident:

a. Has a valid license,

b. Is eligible for further licensing, and

c. Is temporarily absent from Iowa or is temporarily incapacitated at the time for renewal.

**605.15(2)** *Procedure.* The licensee shall apply for an extension by submitting Form 430027 to the department. The form may be obtained from and submitted to a driver's license service center. The licensee may also apply by letter to the address in paragraph 605.12(1) "a."

a. A six-month extension shall be added to the expiration date on the license. When the licensee appears to renew the license, the expiration date of the renewed license will be computed from the expiration date of the original license, notwithstanding the extension.

b. The department shall allow only two six-month extensions.

This rule is intended to implement Iowa Code section 321.196.

[ARC 4000C, IAB 9/12/18, effective 10/17/18; ARC 5495C, IAB 3/10/21, effective 4/14/21]

#### **761—605.16(321) Military extension.**

**605.16(1)** *Application.* A person who qualifies for a military extension of a valid license under Iowa Code section 321.198 and who wishes to have a record of the person's military service extension recorded in the department's computerized issuance system shall apply to the department in person by presentation of the person's unexpired Armed Forces of the United States Geneva Conventions identification card, also known as a common access card (CAC), or by submitting Form 430081 to the department at the address in paragraph 605.12(1) "a." The form shall be signed by the person's commanding officer to verify the military service and be accompanied by a copy of the person's CAC or current active duty orders. Upon approval, the department shall update the department's electronic records with the person's military exception status and issue the person a letter explaining the provisions of Iowa Code section 321.198 regarding military extensions.

**605.16(2)** *Renewal of license after military extension.* When an applicant renews a license after a military extension, the department may require the applicant to provide documentation of both the military service and the date of separation from military service. In accordance with Iowa Code section 321.198(1) "b," the applicant shall pay all applicable fees to renew the license. The applicant may also be waived from the applicable knowledge or driving skills examination in accordance with the provisions of 761—paragraphs 604.21(2) "c" and 604.31(2) "e" and 761—subrules 607.27(5) and 607.28(6).

**605.16(3)** *Reinstatement after sanction.* A person with a military extension whose license has been canceled, suspended or revoked shall comply with the requirements of rule 761—615.40(321) to reinstate the license.

This rule is intended to implement Iowa Code section 321.198.

[ARC 4000C, IAB 9/12/18, effective 10/17/18; ARC 6969C, IAB 4/5/23, effective 5/10/23]

**761—605.17 to 605.19** Reserved.

**761—605.20(321) Fee adjustment for upgrading license.** The fee for upgrading a driver's license shall be computed on a full-year basis. The fee is charged for each year or part of a year between the date of the change and the expiration date on the license.

**605.20(1)** The fee to upgrade a driver's license from one class to another is determined by computing the difference between the current license fee and the new license fee as follows:

- a. Converting noncommercial Class C to Class D—\$4 per year of new license validity.
- b. Converting Class M to Class D with a motorcycle endorsement—\$4 per year of new license validity.
- c. Converting Class M to noncommercial Class C with a motorcycle endorsement—\$2 one-time fee.

**605.20(2)** The fee to add a privilege to a driver's license is computed per year of new license validity as follows:

|  |              |
|--|--------------|
| Noncommercial Class C<br>(full privileges from a restricted Class C) | \$4 per year |
| Motorized bicycle  | \$4 per year |
| Minor's restricted license   | \$4 per year |
| Minor's school license   | \$4 per year |
| Motorcycle instruction permit  | \$2 per year |
| Motorcycle endorsement   | \$2 per year |

This rule is intended to implement Iowa Code sections 321.189 and 321.191.

[ARC 1714C, IAB 11/12/14, effective 12/17/14]

**761—605.21 to 605.24** Reserved.

**761—605.25(321) License renewal.**

**605.25(1)** A licensee who wishes to renew a driver's license shall apply to the department and, if required, pass the appropriate examination.

**605.25(2)** A valid noncommercial license may be renewed within 180 days before the expiration date. The department for good cause may renew a noncommercial license earlier, except the department shall not renew a REAL ID driver's license issued under rule 761—601.7(321) earlier than 180 days before the expiration date if such a renewal would result in noncompliance under 6 CFR Section 37.5(a).

**605.25(3)** Reserved.

**605.25(4)** If the licensee's current residential address, name, date of birth, or sex designation has changed since the previous license was issued, the licensee shall comply with the following:

- a. *Current residential address.* The licensee shall notify the department to establish the current residential address.
- b. *Name.* The licensee shall comply with the requirements of 761—subrule 601.5(5) to establish a name change.
- c. *Date of birth.* The licensee shall comply with the requirements of 761—subrule 601.5(6) to establish a change of date of birth.
- d. *Sex designation.* The licensee shall comply with the requirements of 761—subrule 601.5(7) to establish a change of sex designation.

**605.25(5)** A licensee who has not previously been issued a license that may be accepted for federal identification purposes under 6 CFR Part 37 (a REAL ID license) and wishes to obtain a REAL ID license upon renewal must comply with the requirements of rule 761—601.5(321) to obtain a REAL ID license upon renewal.

**605.25(6)** A licensee who is a foreign national with temporary lawful status must provide documentation of lawful status as required by 761—subrule 601.5(4) at each renewal.

**605.25(7)** The department may determine means or methods for electronic renewal of a noncommercial driver's license.

a. An applicant who meets the following criteria may apply for electronic renewal:

- (1) The applicant must be at least 18 years of age but not yet 70 years of age.
- (2) The applicant completed a satisfactory vision screen or submitted a satisfactory vision report under 761—subrules 604.10(1) to 604.10(3) and updated the applicant's photo at the applicant's last issuance or renewal.
- (3) The applicant's driver's license has not been expired for more than one year.
- (4) The department's records show the applicant is a U.S. citizen.
- (5) The applicant's driver's license is not marked "valid without photo."

(6) The applicant is not seeking to change any of the following information as it appears on the applicant's driver's license:

1. Name.
2. Date of birth.
3. Sex.

(7) The applicant's driver's license is a Class C noncommercial driver's license, a Class D noncommercial driver's license (chauffeur), or Class M noncommercial driver's license (motorcycle) that is not a special license or permit, a temporary restricted license, or a two-year license.

(8) The applicant is not subject to a pending request for reexamination.

(9) The applicant does not wish to change any of the following:

1. Class of license.
2. License endorsements.
3. License restrictions.

(10) The applicant is not subject to any of the following restrictions:

G—No driving when headlights required

J—Restrictions on the back of card

T—Medical report required at renewal

8—Special instruction permit

Q—No interstate or freeway driving

*b.* Notwithstanding any other provision of this subrule to the contrary, the department may accept an electronic renewal application if the license contains a single "J" restriction accompanied by a "7," "I" or "Y" restriction.

*c.* The department reserves the right to deny electronic renewal and to require the applicant to personally apply for renewal at a driver's license service center if it appears to the department that the applicant may have a physical or mental condition that may impair the applicant's ability to safely operate a motor vehicle, even if the applicant otherwise meets the criteria in 605.25(7) "a."

*d.* An applicant who has not previously been issued a driver's license that is compliant with the REAL ID Act of 2005, 49 U.S.C. Section 30301 note, as further defined in 6 CFR Part 37 (a REAL ID license) may not request a REAL ID driver's license by electronic renewal.

**605.25(8)** The department may determine means or methods for electronic renewal of a commercial driver's license.

*a.* An applicant who is otherwise eligible to renew a commercial driver's license must meet the same eligibility requirements for renewing a noncommercial driver's license listed in paragraph 605.25(7) "a" to renew the license electronically, except that numbered paragraph 605.25(7) "a"(9)"3" shall not apply if the applicant is adding or removing the K restriction from the license at the time of renewal. The applicant must also meet the following criteria:

(1) The applicant is not subject to any of the following restrictions or endorsements:

H—Hazardous material

X—Hazardous material and tank

(2) The applicant does not also hold a valid commercial learner's permit under Iowa Code section 321.180(2) as documented by restriction 3 on the commercial driver's license.

(3) An applicant self-certifying to non-excepted interstate driving has a valid medical certificate on file with the department as required under rule 761—607.50(321).

*b.* The requirements in paragraphs 605.25(7) "c" and 605.25(7) "d" shall also apply to a license issued under this subrule.

This rule is intended to implement Iowa Code sections 321.186, 321.188 and 321.196; the REAL ID Act of 2005 (49 U.S.C. Section 30301 note); and 6 CFR Part 37.

[ARC 0347C, IAB 10/3/12, effective 11/7/12; ARC 0895C, IAB 8/7/13, effective 7/9/13; ARC 1073C, IAB 10/2/13, effective 11/6/13; ARC 2071C, IAB 8/5/15, effective 7/14/15; ARC 2337C, IAB 1/6/16, effective 2/10/16; ARC 4000C, IAB 9/12/18, effective 10/17/18; ARC 5942C, IAB 10/6/21, effective 11/10/21; ARC 6307C, IAB 5/4/22, effective 6/8/22; ARC 6969C, IAB 4/5/23, effective 5/10/23]

**761—605.26(321) Graduated driver's license upgrades.** An applicant subject to the graduated driver's license requirements under Iowa Code section 321.180B who is otherwise eligible for a driver's license is eligible to electronically apply to upgrade the applicant's driver's license under this rule.

**605.26(1)** Except for the requirements in subparagraphs 605.25(7) "a"(1) and 605.25(7) "a"(2), the applicant must meet the eligibility requirements listed in paragraph 605.25(7) "a" to upgrade the license electronically and must also meet the following criteria:

*a.* The applicant must have been issued an intermediate license under Iowa Code section 321.180B(2) or a minor's school license under Iowa Code section 321.194 in person.

*b.* The applicant must otherwise be eligible to upgrade a license class privilege under Iowa Code section 321.180B or 321.194.

**605.26(2)** The requirements in paragraphs 605.25(7)“c” and 605.25(7)“d” shall also apply to a license issued under this rule.

**605.26(3)** If an applicant upgrades the applicant's driver's license electronically under this rule to a driver's license with an eight-year expiration date, the applicant is ineligible to electronically renew the applicant's full driver's license at the next renewal period.

**605.26(4)** Notwithstanding any other provision of this rule to the contrary, the department may accept an electronic application to upgrade a license containing a “J” restriction if the “J” restriction is related only to a secondary address.

This rule is intended to implement Iowa Code sections 321.180B and 321.194.

[ARC 5495C, IAB 3/10/21, effective 4/14/21]

[Filed emergency 6/7/90—published 6/27/90, effective 7/1/90]

[Filed emergency 10/24/90—published 11/14/90, effective 10/24/90]

[Filed 5/9/91, Notices 11/14/90, 2/20/91—published 5/29/91, effective 7/3/91]

[Filed 12/18/91, Notice 11/13/91—published 1/8/92, effective 2/12/92]

[Filed 11/4/93, Notice 9/29/93—published 11/24/93, effective 12/29/93]<sup>1</sup>

[Filed emergency 1/10/94—published 2/2/94, effective 1/10/94]

[Filed 10/30/96, Notice 9/25/96—published 11/20/96, effective 12/25/96]

[Filed 1/21/98, Notice 12/17/97—published 2/11/98, effective 3/18/98]

[Filed 10/28/98, Notice 9/23/98—published 11/18/98, effective 12/23/98]

[Filed emergency 7/20/00 after Notice 6/14/00—published 8/9/00, effective 7/24/00]

[Filed 2/15/02, Notice 12/26/01—published 3/20/02, effective 4/24/02]

[Filed 6/19/02, Notice 4/17/02—published 7/10/02, effective 8/14/02]

[Filed emergency 3/21/03—published 4/16/03, effective 3/21/03]

[Filed emergency 6/15/05 after Notice 5/11/05—published 7/6/05, effective 7/1/05]

[Filed 6/14/06, Notice 4/12/06—published 7/5/06, effective 8/9/06]

[Filed 10/11/06, Notice 8/30/06—published 11/8/06, effective 12/13/06]

[Filed ARC 7902B (Notice ARC 7721B, IAB 4/22/09), IAB 7/1/09, effective 8/5/09]

[Filed ARC 9991B (Notice ARC 9874B, IAB 11/30/11), IAB 2/8/12, effective 3/14/12]

[Filed ARC 0347C (Notice ARC 0201C, IAB 7/11/12), IAB 10/3/12, effective 11/7/12]

[Filed ARC 0661C (Notice ARC 0571C, IAB 1/23/13), IAB 4/3/13, effective 5/8/13]

[Filed Emergency ARC 0895C, IAB 8/7/13, effective 7/9/13]

[Filed ARC 1073C (Notice ARC 0894C, IAB 8/7/13), IAB 10/2/13, effective 11/6/13]

[Filed ARC 1714C (Notice ARC 1601C, IAB 9/3/14), IAB 11/12/14, effective 12/17/14]

[Filed Emergency ARC 2071C, IAB 8/5/15, effective 7/14/15]

[Filed ARC 2337C (Notice ARC 2070C, IAB 8/5/15), IAB 1/6/16, effective 2/10/16]

[Filed ARC 2888C (Notice ARC 2800C, IAB 11/9/16), IAB 1/4/17, effective 2/8/17]

[Filed ARC 3451C (Notice ARC 3307C, IAB 9/13/17), IAB 11/8/17, effective 12/13/17]

[Filed ARC 4000C (Notice ARC 3865C, IAB 7/4/18), IAB 9/12/18, effective 10/17/18]

[Filed ARC 4586C (Notice ARC 4476C, IAB 6/5/19), IAB 7/31/19, effective 9/4/19]

[Filed ARC 4851C (Notice ARC 4715C, IAB 10/23/19), IAB 1/1/20, effective 2/5/20]

[Filed ARC 5302C (Notice ARC 5179C, IAB 9/23/20), IAB 12/2/20, effective 1/6/21]

[Filed ARC 5495C (Notice ARC 5384C, IAB 1/13/21), IAB 3/10/21, effective 4/14/21]

[Filed ARC 5942C (Notice ARC 5804C, IAB 7/28/21), IAB 10/6/21, effective 11/10/21]

[Filed ARC 6307C (Notice ARC 6207C, IAB 2/23/22), IAB 5/4/22, effective 6/8/22]

[Filed ARC 6617C (Notice ARC 6466C, IAB 8/10/22), IAB 11/2/22, effective 12/7/22]

[Filed ARC 6969C (Notice ARC 6821C, IAB 1/11/23), IAB 4/5/23, effective 5/10/23]

[Editorial change: IAC Supplement 11/29/23]

- <sup>1</sup> Effective date of December 29, 1993, for 761—605.26(2)“a” and “d,” delayed 70 days by the Administrative Rules Review Committee at its meeting held December 15, 1993; delay lifted by this Committee on January 5, 1994, effective January 6, 1994.



CHAPTER 606  
Reserved



CHAPTER 607  
COMMERCIAL DRIVER LICENSING

**761—607.1(321) Scope.** This chapter applies to licensing persons for the operation of commercial motor vehicles. Unless otherwise stated, the provisions of this chapter are in addition to other motor vehicle licensing rules.

This rule is intended to implement Iowa Code chapter 321.

**761—607.2(17A) Information.**

**607.2(1) Information and location.** Applications, forms and information about the commercial driver's license (CDL) are available at any driver's license service center. Assistance is also available by mail from the Motor Vehicle Division, Iowa Department of Transportation, P.O. Box 9204, Des Moines, Iowa 50306-9204; in person at 6310 SE Convenience Blvd., Ankeny, Iowa; by telephone at 515.244.8725; by facsimile at 515.239.1837; or on the department's website at [www.iowadot.gov](http://www.iowadot.gov).

**607.2(2) Manual.** A copy of a study manual for the commercial driver's license tests is available upon request at any driver's license service center and on the department's website.

This rule is intended to implement Iowa Code section 17A.3.

[ARC 2530C, IAB 5/11/16, effective 6/15/16; ARC 3689C, IAB 3/14/18, effective 4/18/18; ARC 4986C, IAB 3/11/20, effective 4/15/20; ARC 6168C, IAB 2/9/22, effective 3/16/22; Editorial change: IAC Supplement 11/29/23]

**761—607.3(321) Definitions.** The definitions in Iowa Code section 321.1 apply to this chapter of rules. In addition, the following definitions are adopted:

*"Air brake system"* means a system that uses air as a medium for transmitting pressure or force from the driver's control to the service brake. "Air brake system" shall include any braking system operating fully or partially on the air brake principle.

*"Air over hydraulic brakes"* means any braking system operating partially on the air brake and partially on the hydraulic brake principle.

*"Automatic transmission"* means any transmission other than a manual transmission.

*"CDLIS"* means "commercial driver's license information system" as defined in Iowa Code section 321.1.

*"Commercial driver's license downgrade"* or *"CDL downgrade"* means the same as defined in 49 CFR Section 383.5 (October 1, 2023).

*"Commercial motor vehicle"* or *"CMV"* as defined in Iowa Code section 321.1 does not include a motor vehicle designed as off-road equipment rather than as a motor truck, such as a forklift, motor grader, scraper, tractor, trencher or similar industrial-type equipment. "Commercial motor vehicle" also does not include self-propelled implements of husbandry described in Iowa Code subsection 321.1(32).

*"Controlled substance"* as used in Iowa Code section 321.208 means a substance defined in Iowa Code section 124.101.

*"Hazardous materials"* means any material that has been designated as hazardous under 49 U.S.C. Section 5103 and is required to be placarded under 49 CFR Part 172, Subpart F, or any quantity of a material listed as a select agent or toxin in 42 CFR Part 73.

*"Manual transmission"* means a transmission utilizing a driver-operated clutch that is activated by a pedal or lever and a gear-shift mechanism operated either by hand or by foot. All other transmissions, whether semi-automatic or automatic, will be considered automatic.

*"Medical examiner"* means a person who is licensed, certified or registered, in accordance with applicable state laws and regulations, to perform physical examinations. The term includes but is not limited to doctors of medicine, doctors of osteopathy, physician assistants, advanced registered nurse practitioners, and doctors of chiropractic.

*"Medical examiner's certificate"* means a certificate completed and signed by a medical examiner under the provisions of 49 CFR Section 391.43.

*"Medical variance"* means a driver has received one of the following from the Federal Motor Carrier Safety Administration that allows the driver to be issued a medical certificate:

1. An exemption letter permitting operation of a commercial motor vehicle pursuant to 49 CFR Part 381, Subpart C, or 49 CFR Section 391.62, or 49 CFR Section 391.64.
2. A skill performance evaluation certificate permitting operation of a commercial motor vehicle pursuant to 49 CFR Section 391.49.

*"National drug and alcohol clearinghouse"* means the database maintained by the Federal Motor Carrier Safety Administration as defined in 49 CFR Section 382.107 (October 1, 2023).

*"Passenger vehicle"* means either of the following:

1. A motor vehicle designed to transport 16 or more persons including the operator.
2. A motor vehicle of a size and design to transport 16 or more persons including the operator which is redesigned or modified to transport fewer than 16 persons with disabilities. The size of a redesigned or modified vehicle shall be any such vehicle with a gross vehicle weight rating of 10,001 or more pounds.

“*School bus*” means a commercial motor vehicle used to transport pre-primary, primary, or secondary school students from home to school, from school to home, or to and from school-sponsored events unless otherwise provided in Iowa Code section 321.1(69). “School bus” does not include a bus used as a common carrier.

“*Self-certification*” means a written certification of which category of type of driving an applicant for a commercial driver’s license engages in or intends to engage in, from the following categories:

1. Non-excepted interstate. The person certifies that the person operates or expects to operate in interstate commerce, is both subject to and meets the qualification requirements under 49 CFR Part 391, and is required to obtain a medical examiner’s certificate by 49 CFR Section 391.45.
2. Excepted interstate. The person certifies that the person operates or expects to operate in interstate commerce, but engages exclusively in transportation or operations excepted under 49 CFR Section 390.3(f), 391.2, 391.68 or 398.3 from all or parts of the qualification requirements of 49 CFR Part 391, and is therefore not required to obtain a medical examiner’s certificate by 49 CFR Section 391.45.
3. Non-excepted intrastate. The person certifies that the person operates only in intrastate commerce and is subject to state driver qualification requirements.
4. Excepted intrastate. The person certifies that the person operates only in intrastate commerce, but engages exclusively in transportation or operations excepted from all or parts of the state driver qualification requirements as set forth in Iowa Code section 321.449.

“*State,*” as used in this chapter and in “another state” in Iowa Code subsection 321.174(2), “former state of residence” in Iowa Code subsection 321.188(5), or “any state” in Iowa Code subsection 321.208(1), means one of the United States or the District of Columbia unless the context means the state of Iowa.

This rule is intended to implement Iowa Code sections 321.1, 321.174, 321.188, 321.191, 321.193, 321.207 and 321.208.

[ARC 7902B, IAB 7/1/09, effective 8/5/09; ARC 9954B, IAB 1/11/12, effective 1/30/12; ARC 0031C, IAB 3/7/12, effective 4/11/12; ARC 2071C, IAB 8/5/15, effective 7/14/15; ARC 2337C, IAB 1/6/16, effective 2/10/16; ARC 2530C, IAB 5/11/16, effective 6/15/16; ARC 4986C, IAB 3/11/20, effective 4/15/20; ARC 7747C, IAB 4/3/24, effective 5/8/24]

**761—607.4 and 607.5** Reserved.

#### **761—607.6(321) Exemptions.**

**607.6(1)** *Persons exempt.* A person listed in Iowa Code section 321.176A is exempt from commercial driver licensing requirements.

**607.6(2)** *Exempt until April 1, 1992.* Rescinded IAB 6/23/93, effective 7/28/93.

This rule is intended to implement Iowa Code sections 321.1 and 321.176A.

**761—607.7(321) Records.** The operating record of a person who has been issued a commercial driver’s license or a commercial learner’s permit or a person who has been disqualified from operating a commercial motor vehicle shall be maintained as provided in the department’s “Record Management Manual” adopted in 761—Chapter 4.

This rule is intended to implement Iowa Code sections 22.11, 321.12 and 321.199.

[ARC 2071C, IAB 8/5/15, effective 7/14/15; ARC 2337C, IAB 1/6/16, effective 2/10/16; ARC 2530C, IAB 5/11/16, effective 6/15/16]

**761—607.8 and 607.9** Reserved.

#### **761—607.10(321) Adoption of federal regulations.**

**607.10(1)** *Code of Federal Regulations.* The department’s administration of commercial driver’s licenses shall be in compliance with the state procedures set forth in 49 CFR Section 383.73, and this chapter shall be construed to that effect. The department adopts the following portions of the Code of Federal Regulations, which are referenced throughout this chapter of rules:

- a. 49 CFR Section 391.11 as adopted in 661—Chapter 22.
- b. 49 CFR Section 392.5 as adopted in 661—Chapter 22.
- c. 49 CFR Part 380, Subpart F (October 1, 2023).
- d. The following portions of 49 CFR Part 383 (October 1, 2023):
  - (1) Section 383.51, Disqualification of drivers.
  - (2) Subpart E—Testing and Licensing Procedures.

- (3) Subpart F—Vehicle Groups and Endorsements.
- (4) Subpart G—Required Knowledge and Skills.
- (5) Subpart H—Tests.

**607.10(2) Copies of regulations.** Copies of the federal regulations may be reviewed at the state law library or through the Internet at [www.fmcsa.dot.gov](http://www.fmcsa.dot.gov).

This rule is intended to implement Iowa Code sections 321.187, 321.188, 321.207, 321.208 and 321.208A.

[ARC 7902B, IAB 7/1/09, effective 8/5/09; ARC 9954B, IAB 1/11/12, effective 1/30/12; ARC 0031C, IAB 3/7/12, effective 4/11/12; ARC 2071C, IAB 8/5/15, effective 7/14/15; ARC 2337C, IAB 1/6/16, effective 2/10/16; ARC 2530C, IAB 5/11/16, effective 6/15/16; ARC 2986C, IAB 3/15/17, effective 4/19/17; ARC 3840C, IAB 6/6/18, effective 7/11/18; ARC 4401C, IAB 4/10/19, effective 5/15/19; ARC 4986C, IAB 3/11/20, effective 4/15/20; ARC 5018C, IAB 4/8/20, effective 5/13/20; ARC 5547C, IAB 4/7/21, effective 5/12/21; ARC 6307C, IAB 5/4/22, effective 6/8/22; ARC 6970C, IAB 4/5/23, effective 5/10/23; Editorial change: IAC Supplement 7/26/23; ARC 7747C, IAB 4/3/24, effective 5/8/24; ARC 8055C, IAB 6/12/24, effective 7/17/24]

**761—607.11 to 607.14** Reserved.

**761—607.15(321) Application.** An applicant for a commercial driver's license shall comply with the requirements of Iowa Code sections 321.180(2)“e,” 321.182 and 321.188, and 761—Chapter 601, and must provide the proofs of citizenship or lawful permanent residence and state of domicile required by 49 CFR Section 383.71. If the applicant is domiciled in a foreign jurisdiction and applying for a nondomiciled commercial driver's license, the applicant must provide a document required by 49 CFR Section 383.71(f).

This rule is intended to implement Iowa Code sections 321.180, 321.182 and 321.188.

[ARC 2071C, IAB 8/5/15, effective 7/14/15; ARC 2337C, IAB 1/6/16, effective 2/10/16; ARC 2530C, IAB 5/11/16, effective 6/15/16]

**761—607.16(321) Commercial driver's license (CDL).**

**607.16(1) Classes.** The department may issue a commercial driver's license only as a Class A, B or C driver's license. The license class identifies the types of vehicles that may be operated. A commercial driver's license may have endorsements which authorize additional vehicle operations or restrictions which limit vehicle operations.

**607.16(2) Validity.**

*a.* A Class A commercial driver's license allows a person to operate a combination of commercial motor vehicles as specified in Iowa Code sections 321.1(11) and 321.189(1)“a”(1). With the required endorsements and subject to the applicable restrictions, a Class A commercial driver's license is valid to operate any vehicle. Before the department administers the skills test for a Class A commercial driver's license to an applicant for the first time, the applicant must comply with the entry-level driver training requirements as provided in Iowa Code section 321.188.

*b.* A Class B commercial driver's license allows a person to operate a commercial motor vehicle as specified in Iowa Code sections 321.1(11) and 321.189(1)“a”(2). With the required endorsements and subject to the applicable restrictions, a Class B commercial driver's license is valid to operate any vehicle except a truck-tractor semitrailer combination as a chauffeur (Class D) or a vehicle requiring a Class A commercial driver's license. Before the department administers the skills test for a Class B commercial driver's license to an applicant for the first time, the applicant must comply with the entry-level driver training requirements as provided in Iowa Code section 321.188.

*c.* A Class C commercial driver's license allows a person to operate a commercial motor vehicle as specified in Iowa Code sections 321.1(11) and 321.189(1)“a”(3) if the vehicle is designed to transport 16 or more passengers, including the driver, or is used in the transportation of hazardous materials as defined in 49 CFR Section 383.5. With the required endorsements and subject to the applicable restrictions, a Class C commercial driver's license is valid to operate any vehicle except a vehicle requiring a Class A or Class B commercial driver's license.

*d.* A commercial driver's license is valid for operating a motorcycle as a commercial motor vehicle only if the license has a motorcycle endorsement and a hazardous material endorsement. A commercial driver's license is valid for operating a motorcycle as a noncommercial motor vehicle only if the license has a motorcycle endorsement.

*e.* A commercial driver's license valid for eight years shall be issued to a qualified applicant who is at least 18 years of age but not yet 78 years of age. However, the expiration date of the license issued shall not exceed the licensee's 80th birthday.

*f.* A commercial driver's license valid for two years shall be issued to a qualified applicant 78 years of age or older. A two-year license may also be issued, at the discretion of the department, to an applicant whose license is restricted due to vision or other physical disabilities.

*g.* A commercial driver's license is valid for 60 days after the expiration date.

*h.* A person with a commercial driver's license valid for the vehicle operated is not required to obtain a Class D driver's license to operate the vehicle as a chauffeur.

**607.16(3) Requirements.**

*a.* The minimum age to obtain a commercial driver's license is set out in 49 CFR, Part 391, Subpart B, except that, for a person operating solely intrastate, the driver age qualifications are set out in Iowa Code section 321.449(3).

*b.* The applicant shall meet the requirements set forth in rule 761—607.15(321).

**607.16(4)** *Transition from five-year to eight-year licenses.* During the period January 1, 2014, to December 31, 2018, the department shall issue qualified applicants otherwise eligible for an eight-year license a five-year, six-year, seven-year, or eight-year license, subject to all applicable limitations for age and ability. The applicable period shall be randomly assigned to the applicant by the department's computerized issuance system based on a distribution formula intended to spread renewal volumes as equally as practical over the eight-year period beginning January 1, 2019, and ending December 31, 2026.

**607.16(5)** *License extension.*

*a.* As provided in 49 CFR Section 383.153, a person may apply for a 60-day extension of a commercial driver's license if the person:

- (1) Has a valid license,
- (2) Is eligible for further licensing, and
- (3) Is temporarily absent from Iowa or is temporarily incapacitated at the time for renewal.

*b.* The person shall apply for an extension by submitting Form 430027 to the department. The form may be obtained from and submitted to a driver's license service center. The person may also apply by letter to the address in 761—paragraph 605.12(1)“*a.*”

*c.* A 60-day extension shall be added to the expiration date on the license. When the person appears to renew the license, the expiration date of the renewed license will be computed from the expiration date of the original license, notwithstanding the extension.

*d.* The department shall allow only one 60-day extension.

This rule is intended to implement Iowa Code sections 321.1(8) as amended by 2021 Iowa Acts, House File 389, 321.177, 321.182, 321.188, 321.189, 321.196, and 321.449 and 2013 Iowa Acts, chapter 104, section 2.

[ARC 1714C, IAB 11/12/14, effective 12/17/14; ARC 2071C, IAB 8/5/15, effective 7/14/15; ARC 2337C, IAB 1/6/16, effective 2/10/16; ARC 4986C, IAB 3/11/20, effective 4/15/20; ARC 5495C, IAB 3/10/21, effective 4/14/21; ARC 5942C, IAB 10/6/21, effective 11/10/21; ARC 6307C, IAB 5/4/22, effective 6/8/22]

**761—607.17(321) Endorsements.** All endorsements except the hazardous material endorsement continue to be valid without retesting or additional fees when renewing or upgrading a license. The endorsements that authorize additional commercial motor vehicle operations with a commercial driver's license are:

**607.17(1)** *Hazardous material.* A hazardous material endorsement (H) is required to transport hazardous materials. The hazardous material endorsement is only valid when the applicant or holder of the endorsement complies with the Transportation Security Administration's security threat assessment standards specified in 49 CFR Sections 383.71(b)(8) and 383.141. Before the department administers the knowledge test for a hazardous material endorsement to an applicant for the first time, the applicant shall comply with the entry-level driver training requirements as provided in Iowa Code section 321.188. To obtain or retain the hazardous material endorsement, the applicant or holder must pass a knowledge test as required under 49 CFR Section 383.121 and pay the endorsement fee. Retesting and fee payment are also required when an applicant transfers a commercial driver's license from another state unless, as provided in 49 CFR Section 383.73, the transfer applicant provides evidence of passing the knowledge test as required under 49 CFR Section 383.121 within the preceding 24 months. A farmer or a person working for a farmer is not subject to the hazardous material endorsement while operating either a pickup or a special truck within 150 air miles of the farmer's farm to transport supplies to or from the farm.

**607.17(2)** *Passenger vehicle.* A passenger vehicle endorsement (P) is required to operate a passenger vehicle as defined in rule 761—607.3(321). Before the department administers the skills test for a passenger vehicle endorsement to an applicant for the first time, the applicant shall comply with the entry-level driver training requirements as provided in Iowa Code section 321.188.

**607.17(3)** *Tank vehicle.* A tank vehicle endorsement (N) is required to operate a tank vehicle as defined in Iowa Code section 321.1. A vehicle transporting a tank, regardless of the tank's capacity, which does not otherwise meet the definition of a commercial motor vehicle in Iowa Code section 321.1 is not a tank vehicle.

**607.17(4)** *Double/triple trailer.* A double/triple trailer endorsement (T) is required to operate a commercial motor vehicle with two or more towed trailers when the combination of vehicles meets the criteria for a Class A commercial motor vehicle. Operation of a triple trailer combination vehicle is not permitted in Iowa.

**607.17(5)** *Hazardous material and tank.* A combined endorsement (X) authorizes both hazardous material and tank vehicle operations.

**607.17(6) School bus.** A school bus endorsement (S) is required to operate a school bus as defined in rule 761—607.3(321). An applicant for a school bus endorsement must also qualify for a passenger vehicle endorsement. Before the department administers the skills test for a school bus endorsement to an applicant for the first time, the applicant shall comply with the entry-level driver training requirements as provided in Iowa Code section 321.188.

**607.17(7) Exceptions for towing operations.**

*a.* A driver who tows a vehicle in an emergency “first move” from the site of a vehicle malfunction or accident on a highway to the nearest appropriate repair facility is not required to have the endorsement(s) applicable to the towed vehicle. In any subsequent move, a driver who tows a vehicle from one repair or disposal facility to another is required to have the endorsement(s) applicable to the towed vehicle with one exception: A tow truck driver is not required to have a passenger endorsement to tow a passenger vehicle.

*b.* The double/triple trailer endorsement is not required to operate a commercial motor vehicle with two or more towed vehicles that are not trailers.

This rule is intended to implement Iowa Code sections 321.1, 321.176A, 321.188 and 321.189.

[ARC 2071C, IAB 8/5/15, effective 7/14/15; ARC 2337C, IAB 1/6/16, effective 2/10/16; ARC 2530C, IAB 5/11/16, effective 6/15/16; ARC 4986C, IAB 3/11/20, effective 4/15/20]

**761—607.18(321) Restrictions.** The restrictions that may limit commercial motor vehicle operation with a commercial driver’s license are listed in 761—subrule 605.8(3) and are explained below:

**607.18(1) Air brake.** The air brake restriction (L, no air brake equipped CMV) applies to a licensee who either fails the air brake component of the knowledge test or performs the skills test in a vehicle not equipped with air brakes and prohibits the operation of a commercial motor vehicle equipped with an air brake system until the licensee passes the required air brake tests and pays the fee for upgrading the license. Retesting and fee payment are not required when the license is renewed.

**607.18(2) Full air brake.** The full air brake restriction (Z, no full air brake equipped CMV) applies to a licensee who performs the skills test in a vehicle equipped with air over hydraulic brakes and prohibits the operation of a commercial motor vehicle equipped with any braking system operating fully on the air brake principle until the licensee passes the required air brake tests and pays the fee for upgrading the license. Retesting and fee payment are not required when the license is renewed.

**607.18(3) Manual transmission.** The manual transmission restriction (E, no manual transmission equipped CMV) applies to a licensee who performs the skills test in a vehicle equipped with automatic transmission and prohibits the operation of a commercial motor vehicle equipped with a manual transmission until the licensee passes the required tests and pays the fee for upgrading the license. Retesting and fee payment are not required when the license is renewed.

**607.18(4) Tractor-trailer.** The tractor-trailer restriction (O, no tractor trailer CMV) applies to a licensee who performs the skills test in a combination vehicle for a Class A commercial driver’s license with the power unit and towed unit connected with a pintle hook or other non-fifth wheel connection and prohibits operation of a tractor-trailer combination connected by a fifth wheel that requires a Class A commercial driver’s license until the licensee passes the required tests and pays the fee for upgrading the license. Retesting and fee payment are not required when the license is renewed.

**607.18(5) Class A passenger vehicle.** The Class A passenger vehicle restriction (M, no Class A passenger vehicle) applies to a licensee who applies for a passenger endorsement and performs the skills test in a passenger vehicle that requires a Class B commercial driver’s license and prohibits operation of a passenger vehicle that requires a Class A commercial driver’s license.

**607.18(6) Class A and B passenger vehicle.** The Class A and B passenger vehicle restriction (N, no Class A and B passenger vehicle) applies to a licensee who applies for a passenger endorsement and performs the skills test in a passenger vehicle that requires a Class C commercial driver’s license and prohibits operation of a passenger vehicle that requires a Class A or Class B commercial driver’s license.

**607.18(7) Intrastate only.** The intrastate only restriction (K, intrastate only) applies to a licensee who self-certifies to non-excepted intrastate or excepted intrastate driving and prohibits the operation of a commercial motor vehicle in interstate commerce.

**607.18(8) Medical variance.** The medical variance restriction (V, medical variance) applies to a licensee when the department is notified pursuant to 49 CFR Section 383.73(o)(3) that the driver has been issued a medical variance and indicates there is information about a medical variance on the CDLIS driver record.

This rule is intended to implement Iowa Code sections 321.189 and 321.191.

[ARC 2071C, IAB 8/5/15, effective 7/14/15; ARC 2337C, IAB 1/6/16, effective 2/10/16; ARC 2530C, IAB 5/11/16, effective 6/15/16; ARC 4586C, IAB 7/31/19, effective 9/4/19]

**761—607.19** Reserved.

**761—607.20(321) Commercial learner's permit.**

**607.20(1) Validity.**

*a.* A commercial learner's permit allows the permit holder to operate a commercial motor vehicle when accompanied as required by Iowa Code section 321.180(2)“*d.*”

*b.* A commercial learner's permit is valid for one year without retaking the general and endorsement knowledge tests required by Iowa Code section 321.188.

*c.* A commercial learner's permit is invalid after the expiration date of the underlying commercial or noncommercial driver's license issued to the permit holder or the expiration date of the permit whichever occurs first.

*d.* The issuance of a commercial learner's permit is a precondition to the initial issuance of a commercial driver's license. The issuance of a commercial learner's permit is also a precondition to the upgrade of a commercial driver's license if the upgrade requires a skills test. If the permit holder is subject to the requirement to complete entry-level driver training as provided in Iowa Code section 321.188, the permit holder shall complete the training after the permit holder obtains the commercial learner's permit, but before the permit holder takes the required skills test. The holder of a commercial learner's permit is not eligible to take a required driving skills test for the first 14 days after the permit holder is issued the permit. The 14-day period includes the day the commercial learner's permit was issued.

EXAMPLE: The commercial learner's permit is issued on September 1. The earliest date the permit holder would be eligible to take the skills test is September 15.

*e.* A commercial learner's permit is not valid for the operation of a vehicle transporting hazardous materials.

**607.20(2) Requirements.**

*a.* An applicant for a commercial learner's permit must hold a valid Class A, B, C, or D driver's license issued in this state that is not an instruction permit, a special instruction permit, a motorized bicycle license or a temporary restricted license; must be at least 18 years of age; and must meet the requirements to obtain a valid commercial driver's license, including the requirements set forth in Iowa Code section 321.188. However, the applicant does not have to complete the driving skills tests required for a commercial driver's license to obtain a commercial learner's permit.

*b.* The applicant must successfully pass a general knowledge test that meets the federal standards contained in 49 CFR Part 383, Subparts F, G and H, for the commercial motor vehicle the applicant operates or expects to operate, including any endorsement for which the applicant applies.

**607.20(3) Endorsements.** A commercial learner's permit may include the following endorsements. All other endorsements are prohibited on a commercial learner's permit.

*a.* An applicant for a passenger endorsement (P) must take and pass the passenger endorsement knowledge test. A commercial learner's permit holder with a passenger endorsement is prohibited from operating a commercial motor vehicle carrying passengers, other than federal/state auditors and inspectors, test examiners, other trainees, and the commercial driver's license holder accompanying the permit holder required by Iowa Code section 321.180(2)“*d.*”

*b.* An applicant for a school bus endorsement (S) must take and pass the school bus endorsement knowledge test. A commercial learner's permit holder with a school bus endorsement is prohibited from operating a commercial motor vehicle carrying passengers, other than federal/state auditors and inspectors, test examiners, other trainees, and the commercial driver's license holder accompanying the permit holder required by Iowa Code section 321.180(2)“*d.*”

*c.* An applicant for a tank vehicle endorsement (N) must take and pass the tank vehicle endorsement knowledge test. A commercial learner's permit holder with a tank vehicle endorsement may only operate an empty tank vehicle and is prohibited from operating any tank vehicle that previously contained hazardous materials that has not been purged of any residue.

**607.20(4) Restrictions.** A commercial learner's permit may include the air brake (L), medical variance (V), Class A passenger vehicle (M), Class A and B passenger vehicle (N) and intrastate only (K) restrictions described in rule 761—607.18(321). In addition, a commercial learner's permit may include the following restrictions that are specific to the commercial learner's permit:

*a. Passenger.* The passenger restriction (P, no passengers in CMV bus) applies to a permit holder who has a commercial learner's permit with a passenger or school bus endorsement and prohibits the operation of a commercial motor vehicle carrying passengers, other than federal/state auditors and inspectors, test examiners, other trainees, and the commercial driver's license holder accompanying the permit holder required by Iowa Code section 321.180(2)“*d.*”

*b. Cargo.* The cargo restriction (X, no cargo in CMV tank vehicle) applies to a permit holder who has a commercial learner's permit with a tank vehicle endorsement and prohibits the operation of any tank vehicle

containing cargo or any tank vehicle that previously contained hazardous materials that has not been purged of any residue.

This rule is intended to implement Iowa Code sections 321.180, 321.186 and 321.188.

[ARC 2071C, IAB 8/5/15, effective 7/14/15; ARC 2337C, IAB 1/6/16, effective 2/10/16; ARC 2530C, IAB 5/11/16, effective 6/15/16; ARC 3689C, IAB 3/14/18, effective 4/18/18; ARC 4986C, IAB 3/11/20, effective 4/15/20]

**761—607.21 to 607.24** Reserved.

**761—607.25(321) Examination for a commercial driver's license.** In addition to the requirements of 761—Chapter 604, an applicant for a commercial driver's license shall pass the knowledge and skills tests as required in 49 CFR Part 383, Subparts G and H.

This rule is intended to implement Iowa Code section 321.186.

**761—607.26(321) Vision screening.** An applicant for a commercial driver's license or commercial learner's permit must pass a vision screening test administered by the department. The vision standards are given in 761—604.11(321).

This rule is intended to implement Iowa Code sections 321.186 and 321.186A.

[ARC 2071C, IAB 8/5/15, effective 7/14/15; ARC 2337C, IAB 1/6/16, effective 2/10/16]

**761—607.27(321) Knowledge tests.**

**607.27(1) General knowledge test.** The general knowledge test for a commercial driver's license is a written test of topics such as vehicle inspection, operation, safety and control in accordance with 49 CFR Section 383.111.

**607.27(2) Additional tests.** In addition to the general knowledge test for a commercial driver's license, an additional knowledge test is required for each of the following:

- a. Class A license for combination vehicle operation as required in 49 CFR Section 383.111.
- b. Hazardous material endorsement as required in 49 CFR Section 383.121. The knowledge test for a hazardous material endorsement shall not be administered orally or in a language other than English.
- c. Passenger vehicle endorsement as required in 49 CFR Section 383.117.
- d. Tank vehicle endorsement as required in 49 CFR Section 383.119.
- e. Double/triple trailer endorsement as required in 49 CFR Section 383.115.
- f. School bus endorsement as required in 49 CFR Section 383.123. The applicant must also qualify for a passenger vehicle endorsement.
- g. Removal of the air brake restriction as required in 49 CFR Section 383.111.

**607.27(3) Test methods.** All knowledge tests shall be administered in compliance with 49 CFR Section 383.133(b). All tests other than the hazardous material endorsement test may be administered in written form, verbally, or in automated format and can be administered in a foreign language, provided no interpreter is used in administering the test. A verbal test shall be offered only at specified locations. Information about the locations is available at any driver's license service center.

**607.27(4) Waiver.** A waiver of any knowledge test is permitted only as provided in Iowa Code section 321.188(5) and this chapter. The burden of proof of having passed the hazardous material endorsement test within the preceding 24 months rests with the applicant.

**607.27(5) Military waiver.** The department may waive the requirement that an applicant pass a required knowledge test for an applicant who is a current or former military service member as defined in 49 CFR Section 383.5. An applicant for a waiver of the knowledge test under this subrule shall certify and provide evidence, as required by the department, that the following apply:

- a. The applicant is regularly employed or was regularly employed within the past year in a military position specifically designated in 49 CFR Section 383.77.
- b. The applicant is or was operating a vehicle representative of the commercial motor vehicle the applicant operates or expects to operate immediately preceding honorable separation from military service as evidenced by the applicant's certificate of release or discharge from active duty, commonly referred to as a DD form 214.
- c. The applicant has not had more than one driver's license, other than a military license.
- d. The applicant has not had any driver's license suspended, revoked, or canceled.
- e. The applicant has not been convicted of an offense committed while operating any type of motor vehicle that is listed as a disqualifying offense in 49 CFR Section 383.51(b).
- f. The applicant has not had more than one conviction for an offense committed while operating any type of motor vehicle that is listed as a serious traffic violation in 49 CFR Section 383.51(c).

g. The applicant has not had a conviction for violation of a military, state, or local law relating to motor vehicle traffic control, other than a parking violation, arising in connection with any traffic accident, and has no record of an accident in which the applicant was at fault.

**607.27(6) Requirement.** An applicant must pass the applicable knowledge test(s) before taking the skills test. Passing scores for a knowledge test shall meet the standards contained in 49 CFR Section 383.135(a).

This rule is intended to implement Iowa Code sections 321.186 and 321.188.

[ARC 2071C, IAB 8/5/15, effective 7/14/15; ARC 2337C, IAB 1/6/16, effective 2/10/16; ARC 2530C, IAB 5/11/16, effective 6/15/16; ARC 4986C, IAB 3/11/20, effective 4/15/20]

#### **761—607.28(321) Skills test.**

**607.28(1) Content.** The skills test for a commercial driver's license is a three-part test as required in 49 CFR Part 383, Subparts E, G and H.

**607.28(2) Test methods.** All skills tests shall be administered in compliance with 49 CFR Section 383.133(c). Interpreters are prohibited during the administration of skills tests. Applicants must be able to understand and respond to verbal commands and instructions in English by a skills test examiner. Neither the applicant nor the examiner may communicate in a language other than English during the skills test.

**607.28(3) Order.** The skills test must be administered and successfully completed in the following order: pre-trip inspection, basic vehicle control skills, on-road skills. If an applicant fails one segment of the skills test, the applicant cannot continue to the next segment of the test, and scores for the passed segments of the test are only valid during initial issuance of the commercial learner's permit.

**607.28(4) Vehicle.** The applicant shall provide a representative vehicle for the skills test. "Representative vehicle" means a commercial motor vehicle that meets the statutory description for the class of license applied for.

a. To obtain a passenger vehicle endorsement applicable to a specific vehicle class, the applicant must take the skills test in a passenger vehicle, as defined in rule 761—607.3(321), satisfying the requirements of that class, as required in 49 CFR Section 383.117.

b. To obtain a school bus endorsement, the applicant must qualify for a passenger vehicle endorsement and take the skills test in a school bus, as defined in rule 761—607.3(321), in the same vehicle class as the applicant will drive, as required in 49 CFR Section 383.123.

c. To obtain a tank endorsement, the applicant must take the skills test in a representative vehicle for the class of license applied for, but the representative vehicle is not required to be a tank vehicle.

d. To remove an air brake or full air brake restriction, the applicant must take the skills test in a vehicle equipped with an air brake system, as defined in rule 761—607.3(321) and as required in 49 CFR Section 383.113.

e. To remove a manual transmission restriction, the applicant must take the on-road segment of the skills test in a vehicle equipped with a manual transmission, as defined in rule 761—607.3(321).

**607.28(5) Skills test scoring.** Passing scores for a skills test shall meet the standards contained in 49 CFR Section 383.135(b).

**607.28(6) Military waiver.** The department may waive the requirement that an applicant pass a required skills test for an applicant who is on active duty in the military service or who has separated from such service in the past year, provided the applicant meets the requirements of Iowa Code subsection 321.188(6).

**607.28(7) Locations.** The skills test for a commercial driver's license shall be given only at specified locations where adequate testing facilities are available. An applicant may contact any driver's license service center for the location of the nearest skills testing center.

**607.28(8) Fees.** Fees authorized pursuant to Iowa Code sections 321.187A and 321M.6A will be collected by the department or a county treasurer location offering commercial driver's license skills tests.

a. Except as provided in paragraph 607.28(8)"c," the fee for an applicant to schedule the pre-trip vehicle inspection segment of the skills test with the department is \$25. No fees are due to the department for scheduling the basic vehicle control skills or on-road skills segment of the test.

b. Except as provided in paragraph 607.28(8)"c," the fee to schedule the pre-trip vehicle inspection segment of the skills test with a county treasurer is \$25. The fee for a county treasurer to administer the basic vehicle control skills segment is \$25, and the fee to administer the on-road skills segment of the test is \$25. However, if the applicant fails one segment of the driving skills test, no fee shall be due for a subsequent segment of the test.

c. If the applicant is an employee or volunteer of a government agency as defined in Iowa Code section 553.3, the following shall apply:

- (1) The department shall not charge the pre-trip inspection scheduling fee under paragraph 607.28(8)"a."
- (2) A county treasurer may charge only the pre-trip inspection fee under paragraph 607.28(8)"b."

(3) An applicant must provide the department or county treasurer with reasonable proof that the applicant is an employee or volunteer of a qualifying government agency and that a commercial driver's license is necessary for the applicant's employment or volunteer duties. Reasonable proof shall be provided on Form 430311. Alternatively, if the applicant is seeking a skills test from a county treasurer, reasonable proof may include payment of the pre-trip inspection fee by a government agency on behalf of the applicant.

d. If an applicant fails to appear for the pre-trip inspection segment of the skills test, the appointment shall be canceled and no other applicable fees are due.

e. Except as provided in paragraph 607.28(8) "g," new fees will apply if an applicant schedules a new skills test appointment.

f. The department or a county treasurer may collect any fees due and owed for the skills test at the same time any fees are collected as part of the commercial driver's license issuance transaction.

g. Any fees collected under this subrule are nonrefundable. However, nothing in this paragraph shall be construed as preventing the department or a county treasurer from transferring a fee charged for a pre-trip inspection to a new pre-trip inspection if rescheduling the appointment is determined necessary or appropriate as determined by the department or county treasurer upon a showing of good cause.

h. A skills test fee charged under this subrule that remains unpaid may be collected at the person's next driver's license renewal or replacement.

This rule is intended to implement Iowa Code sections 321.186, 321.187A, 321.188 and 321M.6A.

[ARC 2071C, IAB 8/5/15, effective 7/14/15; ARC 2337C, IAB 1/6/16, effective 2/10/16; ARC 2530C, IAB 5/11/16, effective 6/15/16; ARC 3689C, IAB 3/14/18, effective 4/18/18; ARC 4986C, IAB 3/11/20, effective 4/15/20; ARC 5547C, IAB 4/7/21, effective 5/12/21; ARC 6168C, IAB 2/9/22, effective 3/16/22]

**761—607.29(321) Waiver of skills test.** Rescinded IAB 6/23/93, effective 7/28/93.

**761—607.30(321) Third-party testing.**

**607.30(1) Purpose and definitions.** The knowledge tests required by rule 761—607.27(321) and the skills test required by rule 761—607.28(321) may be administered by third-party testers and third-party test examiners approved and certified by the department. For the purpose of administering third-party testing and this rule, the following definitions shall apply:

"College or university" means an Iowa postsecondary school established under Iowa Code chapter 261B.

"Community college" means an Iowa community college established under Iowa Code chapter 260C.

"Government agency" means the same as defined in Iowa Code section 553.3.

"Iowa business" means a corporation, association, partnership, company, firm, or other aggregation of individuals that has an established place of business in this state and that is authorized to conduct business in this state.

"Knowledge test" means the knowledge tests required by rule 761—607.27(321).

"Motor carrier" means the same as defined in 49 CFR Section 390.5.

"Nonprofit" means a corporation or association that satisfies the requirements under Iowa Code chapter 498 or 504.

"Permanent commercial driver training facility" means a facility dedicated to a program of commercial driving instruction that is offered to employees or potential employees of the motor carrier as incident to the motor carrier's commercial operations, that requires at least 40 hours of instruction, and that includes fixed and permanent structures and facilities for the off-road portions of commercial driving instruction, including classroom, pretrip inspection, and basic vehicle control skills. A permanent commercial driver training facility must include a fixed and paved or otherwise hard-surfaced area for basic vehicle control skills testing that is permanently marked and capable of inspection and measurement by the department.

"Public transit system" means the same as defined in Iowa Code section 324A.1.

"Regional transit system" means the same as defined in Iowa Code section 324A.1.

"Skills test" means the skills test required by rule 761—607.28(321).

"Subsidiary" means a company that is partly or wholly owned by a motor carrier that holds a controlling interest in the subsidiary company.

"Third-party test examiner" means the same as defined in Iowa Code section 321.187.

"Third-party tester" means the same as defined in Iowa Code section 321.187.

**607.30(2) Certification of third-party testers.**

a. The department may certify third-party testers to administer knowledge and skills tests. A third-party tester must be one of the following entities:

- (1) A college or university.

- (2) A community college.
- (3) A government agency.
- (4) An Iowa business.
- (5) A nonprofit.
- (6) A public transit system or regional transit system.

*b.* An entity listed in paragraph 607.30(2)“*a*” that seeks certification as a third-party tester shall contact the motor vehicle division and schedule a review of the proposed testing program, which shall include the proposed testing courses and facilities, information sufficient to identify all proposed third-party test examiners, and any other information necessary to demonstrate compliance with 49 CFR Parts 383 and 384 as amended to October 1, 2023, applicable to knowledge and skills testing.

*c.* No entity shall be certified to conduct third-party testing unless and until the entity enters an agreement with the department that meets the requirements of 49 CFR Section 383.75 and demonstrates sufficient ability to conduct knowledge and skills tests in a manner that consistently meets the requirements of 49 CFR Part 383, Subpart E, and 49 CFR Part 384, Subpart B, applicable to knowledge and skills testing.

*d.* The department shall issue a certified third-party tester a certificate of authority that identifies the classes and types of vehicles for which knowledge and skills tests may be administered. The certificate shall be valid for the duration of the agreement executed pursuant to paragraph 607.30(2)“*c*,” unless revoked by the department for engaging in fraudulent activities related to conducting knowledge and skills tests or failing to comply with the requirements, qualifications, and standards of this chapter, the agreement, or 49 CFR Part 383, Subpart E, and 49 CFR Part 384, Subpart B, applicable to knowledge and skills testing.

*e.* The department shall revoke a certificate of authority issued after July 1, 2023, to a third-party tester if the third-party tester fails to administer a minimum of 50 percent of all knowledge and skills tests given in a calendar year to Iowa applicants. However, the department shall not revoke a certificate of authority of a third-party tester who administers a minimum of 10 percent of all knowledge and skills tests given in a calendar year to Iowa applicants if the remainder of the tests are given to current or prospective employees of the third-party tester. For the purpose of this paragraph, an “Iowa applicant” is defined as an individual who holds a valid commercial learner’s permit, commercial driver’s license, noncommercial driver’s license, or nonoperator identification card issued by the department or who otherwise qualifies as a resident of this state under Iowa Code section 321.1A(1).

**607.30(3)** *Certification of third-party test examiners.*

*a.* A certified third-party tester shall not employ or otherwise use as a third-party test examiner a person who has not been approved and certified by the department to administer knowledge or skills tests. Each certified third-party tester shall submit for approval the names of all proposed third-party test examiners to the department. The department shall not approve as a third-party test examiner a person who does not meet the requirements, qualifications, and standards of 49 CFR Part 383, Subpart E, and 49 CFR Part 384, Subpart B, applicable to knowledge and skills testing, including but not limited to all required training and examination and a nationwide criminal background check. The criteria for passing the nationwide criminal background check shall include no felony convictions within the last ten years and no convictions involving fraudulent activities.

*b.* The department shall issue a certificate of authority for each person certified as a third-party test examiner that identifies the certified third-party tester for which the person will administer knowledge or skills tests and the classes and types of vehicles for which the person may administer knowledge or skills tests. The certificate shall be valid for a period of four years from the date of issuance of the certificate.

*c.* The department shall revoke the certificate of authority for a third-party test examiner to administer skills tests if the person holding the certificate does not administer skills tests to at least ten different applicants per calendar year; does not successfully complete the refresher training required by 49 CFR Section 384.228 every four years; is involved in fraudulent activities related to conducting knowledge or skills tests; or otherwise fails to comply with and meet the requirements, qualifications and standards of this chapter or 49 CFR Part 383, Subpart E, and 49 CFR Part 384, Subpart B, applicable to knowledge and skills testing. Notwithstanding anything in this paragraph to the contrary, as provided in 49 CFR Section 383.75, if the person does not administer skills tests to at least ten different applicants per calendar year, the certificate will not be revoked for that reason if the person provides proof of completion of the examiner refresher training in 49 CFR Section 384.228 to the department or successfully completes one skills test under the observation of a department examiner.

*d.* The department shall revoke the certificate of authority for a third-party test examiner to administer knowledge tests if the person holding the certificate does not successfully complete the refresher training required by 49 CFR Section 384.228 every four years, is involved in fraudulent activities related to conducting knowledge or skills tests or otherwise fails to comply with and meet the requirements, qualifications and standards of this chapter or 49 CFR Part 383, Subpart E, and 49 CFR Part 384, Subpart B, applicable to knowledge testing.

e. A third-party test examiner certified by the department to administer skills tests who is also a skills instructor shall not administer a skills test to an applicant who received skills training from that third-party test examiner.

f. A third-party test examiner may only administer CDL tests for the examiner's primary employer, unless authorized by the department to administer CDL tests for another county or third-party tester.

**607.30(4) Bond.** As a condition of certification in accordance with 49 CFR Section 383.75, a third-party tester that is not a government agency as defined in Iowa Code section 553.3 must maintain a bond in the amount of \$50,000 to pay for the retesting of drivers in the event that the third-party tester or one or more of its third-party test examiners are involved in fraudulent activities related to conducting tests of CDL applicants.

**607.30(5) Training and refresher training for third-party test examiners.** All training and refresher training required under this rule shall be provided by the department, in form and content that meet the recommendations of the American Association of Motor Vehicle Administrators' International Third-Party Examiner/Tester Certification Program.

This rule is intended to implement Iowa Code section 321.187.

[ARC 2530C, IAB 5/11/16, effective 6/15/16; ARC 4986C, IAB 3/11/20, effective 4/15/20; ARC 6168C, IAB 2/9/22, effective 3/16/22; ARC 6706C, IAB 11/30/22, effective 1/4/23; ARC 7747C, IAB 4/3/24, effective 5/8/24]

### **761—607.31(321) Test results.**

**607.31(1) Period of validity.** Passing knowledge and skills test results shall remain valid for a period of one year.

**607.31(2) Retesting.** Subject to rule 761—607.28(321), an applicant shall be required to repeat only the knowledge test(s) or part(s) of the skills test that the applicant failed. An applicant who fails a test shall not be permitted to repeat that test the same day. An applicant may be required to repeat a test if the department determines the test was improperly administered.

**607.31(3) Skills test results from other states.** As required by 49 CFR Section 383.79, the department shall accept the valid results of a skills test administered to an applicant who is domiciled in the state of Iowa and that was administered by another state, in accordance with 49 CFR Part 383, Subparts F, G and H, in fulfillment of the applicant's testing requirements under 49 CFR Section 383.71 and the state's test administration requirements under 49 CFR Section 383.73. The results must be transmitted directly from the testing state to the department as required by 49 CFR Section 383.79.

**607.31(4) Knowledge and skills test results from certified third-party testers.** A third-party tester certified under rule 761—607.30(321) shall transmit the test results of tests administered by the third-party tester through secure electronic means determined by the department. The department may retest any person who has passed a knowledge or skills test administered by a certified third-party tester if it appears to the department that the knowledge or skills test administered by the third-party tester was administered fraudulently or improperly, and as needed to meet the third-party test examiner oversight requirements of 49 CFR Parts 383 and 384 applicable to knowledge and skills testing.

**607.31(5) Downgrade or cancellation when retesting is required.**

a. When retesting is required under subrule 607.31(2) or 607.31(4), the department shall notify the person of the requirement to retake the applicable knowledge or skills test.

b. If the person fails to contact the department within 30 days after receipt of the notice, fails to appear for a scheduled retest, or fails the knowledge or skills test, the department shall, in accordance with the authority in 49 CFR Section 383.5 and Iowa Code section 321.201, take one of the following actions:

(1) Downgrade the person's commercial driver's license or commercial learner's permit if the person held valid noncommercial driving privileges prior to obtaining the license or permit.

(2) Cancel the person's commercial driver's license or commercial learner's permit pursuant to 761—subrule 615.7(3) if the applicant did not hold valid noncommercial driving privileges prior to obtaining the license or permit.

c. When a person's commercial driver's license or commercial learner's permit has been downgraded or canceled under this subrule, the person must comply with all applicable retesting requirements in order to regain the license or permit, in addition to any other applicable requirements for licensure.

This rule is intended to implement Iowa Code sections 321.180, 321.186, 321.187 as amended by 2022 Iowa Acts, Senate File 2337, section 1, 321.188 and 321.201.

[ARC 2071C, IAB 8/5/15, effective 7/14/15; ARC 2337C, IAB 1/6/16, effective 2/10/16; ARC 2530C, IAB 5/11/16, effective 6/15/16; ARC 3689C, IAB 3/14/18, effective 4/18/18; ARC 4986C, IAB 3/11/20, effective 4/15/20; ARC 6307C, IAB 5/4/22, effective 6/8/22; ARC 6706C, IAB 11/30/22, effective 1/4/23]

### **761—607.32(321) Knowledge and skills testing of nondomiciled military personnel.**

**607.32(1) *Role of state of duty station.*** The department may accept an application for a CLP or CDL, including an application for waiver of the knowledge test as provided in subrule 607.27(5), if the applicant is an active duty military service member stationed, but not domiciled, in Iowa, and the department has an agreement to accept such applications with the applicant's state of domicile as provided in 49 CFR Section 383.79.

*a.* The applicant shall certify and provide evidence that the following apply:

- (1) The applicant is regularly employed or was regularly employed within the past year in a military position requiring operation of a commercial motor vehicle.
- (2) The applicant has a valid driver's license from the applicant's state of domicile.
- (3) The applicant has a valid active duty military identification card.
- (4) The applicant has a current copy of either the applicant's military leave and earnings statement or the applicant's orders.

*b.* If the applicant meets the requirements of paragraph 607.32(1) "a" and the department has an agreement with the applicant's state of domicile as provided in this subrule, the department may do either of the following:

- (1) Administer the knowledge and skills tests to the applicant as appropriate in accordance with 49 CFR Part 383, Subparts F, G, and H, if the state of domicile requires those tests; or
- (2) Waive the knowledge and skills tests in accordance with 49 CFR Section 383.77 and this chapter if the state of domicile also permits waiver of the knowledge and skills test.

*c.* The department may destroy the applicant's driver's license on behalf of the state of domicile unless the state of domicile requires the driver's license to be surrendered to the state of domicile's driver's licensing agency.

**607.32(2) *Electronic transmission of application and test results.*** The department shall transmit to the state of domicile the applicant's application, any supporting documents and the results of any skills or knowledge tests administered as provided under this rule.

**607.32(3) *Role of state of domicile.*** If the department has an agreement with the applicant's state of duty station, upon completion of the applicant's application pursuant to 49 CFR Section 383.71 and any testing administered by the applicant's state of duty station pursuant to 49 CFR Sections 383.71 and 383.73, the department may do all of the following:

- a.* Accept the completed application, any supporting documents, and the results of the knowledge and skills tests administered by the applicant's state of duty station.
- b.* Issue the applicant a CLP or CDL.

This rule is intended to implement Iowa Code sections 321.180, 321.186, 321.187, and 321.188 and 49 CFR Part 383.

[ARC 4986C, IAB 3/11/20, effective 4/15/20]

**761—607.33 and 607.34** Reserved.

**761—607.35(321) Issuance of commercial driver's license and commercial learner's permit.** A commercial driver's license or commercial learner's permit issued by the department shall include the information and markings required by Iowa Code section 321.189(2) "b."

This rule is intended to implement Iowa Code section 321.189.

[ARC 2071C, IAB 8/5/15, effective 7/14/15; ARC 2337C, IAB 1/6/16, effective 2/10/16; ARC 2530C, IAB 5/11/16, effective 6/15/16]

**761—607.36(321) Conversion to commercial driver's license.** Rescinded IAB 6/23/93, effective 7/28/93.

**761—607.37(321) Commercial driver's license renewal.** The department shall administer commercial driver's license renewals as required by 49 CFR Section 383.73.

**607.37(1) *Licensee requirements.*** To renew a commercial driver's license, the licensee shall apply at a driver's license service center and complete the following requirements:

*a.* The licensee shall make a written self-certification of type of driving as required by rule 761—607.50(321) and, if required, provide a current medical examiner's certificate unless the person's medical examiner's certificate is provided to the department electronically by the Federal Motor Carrier Safety Administration.

*b.* If the licensee has and wishes to retain a hazardous material endorsement, the licensee shall pass the test required in 49 CFR Section 383.121 and comply with the Transportation Security Administration security threat assessment standards specified in 49 CFR Sections 383.71(b)(8) and 383.141 for such endorsement. A lawful permanent resident of the United States must also provide the licensee's U.S. Citizenship and Immigration Services alien registration number.

c. The licensee shall provide proof of citizenship or lawful permanent residency and state of domicile as required by rule 761—607.15(321) and 49 CFR 383.73(d)(7). Proof of citizenship or lawful permanent residency is not required if the licensee provided such proof at initial issuance or a previous renewal or upgrade of the license and the department has a notation on the licensee's record confirming that the required proof of legal citizenship or legal presence check was made and the date on which it was made.

d. If the licensee is domiciled in a foreign jurisdiction and renewing a non-domiciled commercial driver's license, the licensee must provide a document required by 49 CFR 383.71(f) at each renewal.

**607.37(2) *Early renewal.*** A valid commercial driver's license may be renewed 90 days before the expiration date. If this is impractical, the department for good cause may renew a license earlier, not to exceed 364 days prior to the expiration date. The department may allow renewal earlier than 364 days prior to the expiration date for active military personnel being deployed due to actual or potential military conflict.

This rule is intended to implement Iowa Code sections 321.186, 321.188 and 321.196.

[ARC 2337C, IAB 1/6/16, effective 2/10/16; ARC 2337C, IAB 1/6/16, effective 2/10/16; ARC 2530C, IAB 5/11/16, effective 6/15/16; ARC 4986C, IAB 3/11/20, effective 4/15/20; ARC 5547C, IAB 4/7/21, effective 5/12/21]

**761—607.38(321) Transfers from another state.** Upon initial application for an Iowa license, an Iowa resident who has a valid commercial driver's license from a former state of residence is not required to retest except as specified in Iowa Code subsection 321.188(5) but is required to pay the applicable endorsement and restriction removal fees.

This rule is intended to implement Iowa Code sections 321.188 and 321.191.

**761—607.39(321) Disqualification.**

**607.39(1) *Date.*** A disqualifying act, action or offense under Iowa Code section 321.208, that occurred before July 1, 1990, shall not be grounds for disqualification from operating a commercial motor vehicle.

**607.39(2) *Notice.*** A 30-day advance notice of disqualification shall be served by the department in accordance with rule 761—615.37(321). Pursuant to Iowa Code subsection 321.208(12), a peace officer on behalf of the department may serve the notice of disqualification immediately.

**607.39(3) *Hearing and appeal process.*** A person who has received a notice of disqualification may contest the disqualification in accordance with 761—615.38(17A,321).

**607.39(4) *Reduction of lifetime disqualification.***

a. As permitted by 49 CFR Section 383.51, a person subject to lifetime disqualification of the person's commercial driving privileges may apply to the department for reinstatement. The approval is subject to the discretion of the department and subject to the following requirements:

- (1) The request may not be made prior to ten years from the effective date of the lifetime disqualification.
- (2) The person must submit the request in a manner prescribed by the department.

(3) If the driving record contains alcohol-related or drug-related offenses that resulted in the lifetime disqualification, the person must have completed an alcohol or drug evaluation and have completed any recommended treatment which meets or exceeds the minimum standards approved by the Iowa department of health and human services. Evidence of a completed evaluation and treatment must be on file with the department or submitted with the application for reinstatement.

(4) Within the ten years preceding the request, the person must not have any of the following moving violation convictions:

1. A drug or alcohol offense.
2. Leaving the scene of an accident.
3. A felony involving the use of any motor vehicle.
4. Any moving violation while operating a commercial motor vehicle.

(5) The department may request, and the person shall provide, any additional information or documentation necessary to determine the person's eligibility for reinstatement or general fitness for licensure.

b. If the department finds the person is eligible for reinstatement under this subrule, the person shall do all of the following prior to reinstatement:

- (1) Pay all outstanding reinstatement fees.
- (2) Meet all outstanding reinstatement requirements.
- (3) Pass the required knowledge, vision, and skills tests as specified in Iowa Code section 321.188.
- (4) Complete any other courses or requirements as required by the director.

c. As provided in 49 CFR Section 383.51(a)(6), a person who has previously had the person's commercial driving privileges reinstated pursuant to this subrule shall not be eligible to apply for reinstatement following conviction of a subsequent disqualifying offense.

*d.* If the department determines the person is not eligible for reinstatement as provided in this subrule, the department shall send notice by first-class mail to the person's mailing address as shown on departmental records that the lifetime disqualification remains in effect.

**607.39(5) *Fraud related to testing and issuance.***

*a.* As required by 49 CFR Section 383.73(k) and Iowa Code section 321.201(2)"*b*," the department shall disqualify the commercial driver's license or commercial learner's permit of a person convicted or suspected of fraud related to the testing for or issuance of a commercial driver's license or commercial learner's permit.

*b.* Upon receipt of a person's conviction of fraud related to the issuance of the commercial driver's license or commercial learner's permit, the department shall disqualify the person's commercial driver's license or commercial learner's permit for one year.

*c.* Upon receipt of credible evidence that a person is suspected of committing fraud relating to the issuance of a commercial driver's license or a commercial learner's permit, the department shall notify the person of the requirement to retake the applicable knowledge or skills test. Within 30 days of receiving notice from the department, the person is required to contact the department to retake the knowledge or skills test. If the person fails to contact the department within 30 days after the notice, or the person fails the knowledge or skills test, or does not take the test, the department shall disqualify the person's commercial driver's license or commercial learner's permit.

*d.* Once a person's commercial driver's license or commercial learner's permit has been disqualified, the person must reapply following the usual procedures as provided in Iowa Code section 321.188 and this chapter.

This rule is intended to implement Iowa Code chapter 17A and section 321.208.

[ARC 2530C, IAB 5/11/16, effective 6/15/16; ARC 4986C, IAB 3/11/20, effective 4/15/20; Editorial change: IAC Supplement 11/29/23]

**761—607.40(321) Sanctions.** When a person's motor vehicle license is denied, canceled, suspended, revoked or barred, the person is also disqualified from operating a commercial motor vehicle.

This rule is intended to implement Iowa Code section 321.208.

**761—607.41 to 607.44** Reserved.

**761—607.45(321) Reinstatement.** To reinstate a commercial driver's license after completion of a period of disqualification, a person shall appear at a driver's license service center. The person must also meet the vision standards for licensing, pass the applicable knowledge test(s) and the skills test, and pay the required reinstatement fee and the fees for a new license.

This rule is intended to implement Iowa Code sections 321.191 and 321.208.

[ARC 4986C, IAB 3/11/20, effective 4/15/20]

**761—607.46 to 607.48** Reserved.

**761—607.49(321) Restricted commercial driver's license.**

**607.49(1) *Scope.*** This rule pertains to the issuance of restricted commercial driver's licenses to employees of the following designated farm-related service industries: agrichemical businesses, custom harvesters, farm retail outlets and suppliers and livestock feeders as permitted by 49 CFR 383.3(f). A restricted commercial driver's license shall meet all requirements of a regular commercial driver's license, as set out in Iowa Code chapter 321 and this chapter, except as specified in this rule.

**607.49(2) *Validity.***

*a.* A restricted commercial driver's license allows the licensee to drive a commercial motor vehicle for agricultural input purposes. The license is valid to:

(1) Operate Group B and Group C commercial motor vehicles including tank vehicles and vehicles equipped with air brakes, except passenger vehicles.

(2) Transport the hazardous materials listed in paragraph 607.49(2)"*b*."

(3) Operate only during the current, validated seasonal period.

(4) Operate between the employer's place of business and the farm currently being served, not to exceed 150 miles.

*b.* A restricted commercial driver's license is not valid for transporting hazardous materials requiring placarding, except as follows:

(1) Liquid fertilizers such as anhydrous ammonia may be transported in vehicles or implements of husbandry with total capacities of 3,000 gallons or less.

(2) Solid fertilizers such as ammonium nitrate may be transported provided they are not mixed with any organic substance.

(3) A hazardous material endorsement is not needed to transport the products listed in the preceding subparagraphs.

c. When not driving for agricultural input purposes, the license is valid for operating a noncommercial motor vehicle that may be legally operated under the noncommercial license held by the licensee.

**607.49(3) Requirements.**

a. The applicant must have two years of previous driving experience. This means that the applicant must have held a license that permits unaccompanied driving for at least two years. This does not include a motorized bicycle license, a minor's school license or a minor's restricted license.

b. The applicant must have a good driving record for the most recent two-year period, as defined in subrule 607.49(4).

c. An applicant who currently holds an unrestricted commercial driver's license is not eligible for issuance of a restricted commercial driver's license.

**607.49(4) Good driving record.** A "good driving record" means a driving record showing:

a. No multiple licenses.

b. No driver's license suspensions, revocations, disqualifications, denials, bars, or cancellations of any kind.

c. No convictions in any type of motor vehicle for:

(1) Driving under the influence of alcohol or drugs.

(2) Leaving the scene of an accident.

(3) Committing any felony involving a motor vehicle.

(4) Speeding 15 miles per hour or more over the posted speed limit.

(5) Reckless driving, drag racing, or eluding or attempting to elude a law enforcement officer.

(6) Improper or erratic lane changes.

(7) Following too closely.

(8) A moving violation that contributed to a motor vehicle accident.

(9) A violation deemed serious under rule 761—615.17(321).

d. No record of contributive accidents, as defined in rule 761—615.1(321).

**607.49(5) Issuance.**

a. The knowledge and skills tests described in rules 761—607.27(321) and 761—607.28(321) are waived.

b. A restricted commercial driver's license shall be coded with restriction "W" on the face of the driver's license, with the restriction explained in text on the back of the driver's license. In addition, the license shall be issued with a restriction stating the license's period of validity.

c. The expiration date for a restricted commercial driver's license that is converted to this license from another Iowa license shall carry the same expiration date as the previous license.

d. A restricted commercial driver's license may be renewed for the period of time specified in Iowa Code section 321.196. The licensee's good driving record shall be confirmed at the time of renewal.

e. The fee for a restricted commercial driver's license shall be as specified in Iowa Code section 321.191.

f. On or after January 1, 2023, a licensee may have up to three individual periods of validity for a restricted commercial driver's license, provided the cumulative period of validity for all individual periods does not exceed 210 days in any calendar year. An individual period of validity may be 70, 105, or 210 consecutive days, at the election of the licensee. A licensee may add 35 days to an individual period of validity by applying for an extension, subject to the 210-day cumulative maximum period of validity. A request for extension must be made no later than the date of expiration of the individual period of validity for which an extension is requested; a request for extension made after that date shall be treated as a request for a new individual period of validity. An extension shall be calculated from the date of expiration of the individual period of validity for which an extension is requested. Any period of validity authorized previously by another state's license shall be considered a part of the 210-day cumulative maximum period of validity.

g. A restricted commercial driver's license must be validated for commercial motor vehicle operation for each individual period of validity. This means that the applicant/licensee must have the person's good driving record confirmed at each application for an individual period of validity. Upon confirmation, the department shall issue a replacement license with a restriction validating the license for that individual period of validity, provided the person is otherwise eligible for the license. The fee for a replacement license shall be as specified in Iowa Code section 321.195.

h. The same process must be repeated for each individual period of validity within a calendar year.

This rule is intended to implement Iowa Code section 321.176B.

[ARC 2071C, IAB 8/5/15, effective 7/14/15; ARC 2337C, IAB 1/6/16, effective 2/10/16; ARC 2530C, IAB 5/11/16, effective 6/15/16; ARC 4986C, IAB 3/11/20, effective 4/15/20; ARC 6970C, IAB 4/5/23, effective 5/10/23; ARC 7747C, IAB 4/3/24, effective 5/8/24]

**761—607.50(321) Self-certification of type of driving and submission of medical examiner's certificate.**

**607.50(1)** *Applicants for commercial learner's permit, restricted CDL, or new, transferred, renewed or upgraded CDL.*

a. A person shall provide to the department a self-certification of type of driving if the person is applying for:

- (1) A commercial learner's permit,
- (2) An initial commercial driver's license,
- (3) A transfer of a commercial driver's license from a prior state of domicile to the state of Iowa,
- (4) Renewal of a commercial driver's license,
- (5) A license upgrade for a commercial driver's license or an endorsement authorizing the operation of a commercial motor vehicle not covered by the current commercial driver's license, or
- (6) A restricted commercial driver's license.

b. The self-certification shall be on a form or in a format, which may be electronic, as provided by the department.

**607.50(2)** *Submission of medical examiner's certificate by persons certifying to non-excepted interstate driving.*

Every person who self-certifies to non-excepted interstate driving must give the department a copy of the person's current medical examiner's certificate, unless the person's medical examiner's certificate is provided to the department electronically by the Federal Motor Carrier Safety Administration. The department shall not issue, transfer, renew, or upgrade a license until the department receives a medical examiner's certificate that complies with the requirements of this subrule, or unless the person changes the person's self-certification of type of driving to a type other than non-excepted interstate driving. When the department receives a current medical examiner's certificate, the department shall post a medical certification status of "certified" on the person's CDLIS driver's record. A person who self-certifies to a type of driving other than non-excepted interstate shall have no medical certification status on the CDLIS driver's record.

**607.50(3)** *Maintaining certified status.* To maintain a medical certification status of "certified," a person who self-certifies to non-excepted interstate driving must give the department a copy of each subsequently issued medical examiner's certificate valid for the person unless the person's medical examiner's certificate is provided to the department electronically by the Federal Motor Carrier Safety Administration.

**607.50(4)** *CDL downgrade.* If the medical examiner's certificate or medical variance for a person self-certifying to non-excepted interstate driving expires or if the Federal Motor Carrier Safety Administration notifies the department that the person's medical variance was removed or rescinded, the department shall post a medical certification status of "not certified" to the person's CDLIS driver's record and shall initiate a downgrade of the person's commercial driver's license or commercial learner's permit. The medical examiner's certificate of a person who fails to maintain a medical certification status of "certified" as required by subrule 607.50(3) shall be deemed to be expired on the date of expiration of the last medical examiner's certificate filed for the person as shown by the person's CDLIS driver's record. The downgrade will be initiated and completed as follows:

a. The department shall give the person written notice that the person's medical certification status is "not certified" and that the commercial motor vehicle privileges will be removed from the person's commercial driver's license or commercial learner's permit 60 days after the date the medical examiner's certificate or medical variance expired or the medical variance was removed or rescinded unless the department receives a current medical certificate or medical variance or the person self-certifies to a type of driving other than non-excepted interstate.

b. If the department receives a current medical examiner's certificate or medical variance before the end of the 60-day period, the department shall post a medical certification status of "certified" on the person's CDLIS driver's record and shall terminate the downgrade of the person's commercial driver's license or commercial learner's permit.

c. If the person self-certifies to a type of driving other than non-excepted interstate before the end of the 60-day period, the department shall not remove the commercial motor vehicle privileges from the person's commercial driver's license or commercial learner's permit, and the person will have no medical certification status on the person's CDLIS driver's record.

d. If the requirements in either paragraph 607.50(4) "b" or "c" are not met before the end of the 60-day period, the department shall remove the commercial motor vehicle privileges from the person's commercial driver's license or commercial learner's permit and shall leave the person's medical certification status as "not certified" on the person's CDLIS driver's record.

**607.50(5)** *Establishment or reestablishment of "certified" status.* A person who has no medical certification status or whose medical certification status has been posted as "not certified" on the person's CDLIS driver's record may have the person's status established or reestablished as "certified" if the department receives a current medical examiner's certificate or medical variance. A person who has failed to self-certify to a type of driving or has self-certified to a type of driving other than non-excepted interstate must also make a self-certification of type of driving to

non-expected interstate driving. The department shall then post a medical certification status of “certified” on the person’s CDLIS driver’s record.

**607.50(6) *Reestablishment of the CDL privilege.*** A person whose commercial motor vehicle privileges have been removed from the person’s commercial driver’s license or commercial learner’s permit under the provisions of paragraph 607.50(4)“d” may have the person’s commercial motor vehicle privileges reestablished if either of the following occurs:

*a.* The department receives the person’s current medical examiner’s certificate or medical variance. A person who has failed to self-certify to a type of driving must also make an initial self-certification of type of driving to non-expected interstate driving. The department shall then post a medical certification status of “certified” on the person’s CDLIS driver’s record and reestablish the commercial motor vehicle privileges, provided that the person otherwise remains eligible for a commercial driver’s license or commercial learner’s permit.

*b.* The person self-certifies to a type of driving other than non-expected interstate. The department shall then reestablish the commercial motor vehicle privileges, provided that the person otherwise remains eligible for a commercial driver’s license or commercial learner’s permit; the person will have no medical certification status on the driver’s CDLIS driver’s record.

**607.50(7) *Change of type of driving.*** A person may change the person’s self-certification of type of driving at any time. As required by subrule 607.50(2), the department must receive a copy of the person’s current medical examiner’s certificate prepared by a medical examiner for a person certifying to non-expected interstate driving.

**607.50(8) *Record keeping.*** The department shall comply with the medical record-keeping requirements set forth in 49 CFR Section 383.73.

**607.50(9) *Medical examiner’s certificate conflict.*** As required by 49 CFR Sections 383.71 and 383.73, in the event of a conflict between the medical certification information provided electronically by the Federal Motor Carrier Safety Administration and a paper copy of the medical examiner’s certificate, the medical certification information provided electronically by the Federal Motor Carrier Safety Administration shall supersede.

This rule is intended to implement Iowa Code sections 321.182, 321.188 and 321.207.

[ARC 9954B, IAB 1/11/12, effective 1/30/12; ARC 0031C, IAB 3/7/12, effective 4/11/12; ARC 2071C, IAB 8/5/15, effective 7/14/15; ARC 2337C, IAB 1/6/16, effective 2/10/16; ARC 2530C, IAB 5/11/16, effective 6/15/16; ARC 4986C, IAB 3/11/20, effective 4/15/20; ARC 5547C, IAB 4/7/21, effective 5/12/21]

## **761—607.51(321) National drug and alcohol clearinghouse.**

**607.51(1) *Applicability.*** This rule applies to:

- a.* An applicant for or holder of a commercial learner’s permit,
- b.* An applicant for or holder of a commercial driver’s license,
- c.* An applicant seeking to transfer a commercial driver’s license from a prior state of domicile to the state of Iowa,
- d.* An applicant seeking renewal of a commercial driver’s license,
- e.* An applicant seeking to upgrade a commercial driver’s license or add an endorsement authorizing the operation of a commercial motor vehicle not covered by the current commercial driver’s license, or
- f.* An applicant for or holder of a restricted commercial driver’s license.

**607.51(2) *Issuance procedures.*** Prior to issuing the license or permit, the department shall request information from the national drug and alcohol clearinghouse to determine if the person is prohibited from operating a commercial motor vehicle pursuant to 49 CFR 382.501(a). The department shall not issue, renew, transfer, or upgrade the license or permit if the person is prohibited from operating a commercial motor vehicle pursuant to 49 CFR 382.501(a). However, this subrule shall not take effect prior to the date established by the Federal Motor Carrier Safety Administration in 49 CFR Section 383.73 for state driver’s license agency compliance with national drug and alcohol clearinghouse requirements.

**607.51(3) *CDL downgrade.*** Upon receiving notification that pursuant to 49 CFR 382.501(a) the person is prohibited from operating a commercial motor vehicle, the department shall downgrade the license or permit and record the downgrade on the CDLIS driver record within 60 days of the department’s receipt of such notification. However, this subrule shall not take effect prior to the date established by the Federal Motor Carrier Safety Administration in 49 CFR Section 383.73 for state driver’s license agency compliance with national drug and alcohol clearinghouse requirements. The downgrade will be initiated and completed as follows:

- a.* The department shall give the person written notice that the person is prohibited from operating a commercial motor vehicle due to notification the department received from the national drug and alcohol clearinghouse that the person has engaged in conduct prohibited by 49 CFR 382.501(a) and that upon receipt of the notification, the department initiated a downgrade of the person’s CLP or CDL.

b. If the department receives notification that the person is no longer prohibited from operating a commercial motor vehicle before the downgrade is completed, the department shall terminate the downgrade process without removing the CLP or CDL privilege from the driver's license, transmit the information to the person's CDLIS driver record, and send written notice to the person.

c. If, after the downgrade is completed, the department receives notification from the national drug and alcohol clearinghouse that a driver is no longer prohibited from operating a commercial motor vehicle, the department shall record the end of the downgrade on the person's CDLIS driver record, reinstate the CLP or CDL privilege to the driver's license, and send written notice to the person.

d. If, after the downgrade is completed, the department receives notification from the national drug and alcohol clearinghouse that the person was erroneously identified as prohibited from operating a commercial motor vehicle, the department shall reinstate the CLP or CDL privilege to the driver's license as expeditiously as possible and remove from the CDLIS driver record and driving record any reference related to the person's erroneous prohibited status.

**607.51(4) Limitation on hearing and appeal.** An informal settlement, hearing, or appeal to contest the downgrade is limited to a determination of whether the facts required by Iowa Code sections 321.188 and 321.207 and this rule are true. The merits of the information conveyed by the national drug and alcohol clearinghouse to the department shall not be considered.

This rule is intended to implement Iowa Code sections 321.188 and 321.207.

[ARC 7747C, IAB 4/3/24, effective 5/8/24]

#### **761—607.52(321) Determination of gross vehicle weight rating.**

**607.52(1) Actual weight prohibited.** In determining whether the vehicle is a representative vehicle for the skills test and the group of commercial driver's license for which the applicant is applying, the vehicle's gross weight rating or gross combination weight rating must be used, not the vehicle's actual gross weight or gross combination weight. For purposes of this rule, "gross weight rating" and "gross combination weight rating" mean as defined in 49 CFR Section 383.5.

**607.52(2) Vehicle without legible manufacturer's certification label.** To complete a skills test using a vehicle that has no legible manufacturer's certification label, whether a power unit or towed vehicle, the applicant must provide documentation of the vehicle's gross vehicle weight rating, such as a manufacturer's certificate of origin, a title, or the vehicle identification number information for the vehicle. In the absence of such documentation, the vehicle may not be used, either alone or in combination.

This rule is intended to implement Iowa Code section 321.1.

[ARC 2071C, IAB 8/5/15, effective 7/14/15; ARC 2337C, IAB 1/6/16, effective 2/10/16; ARC 2530C, IAB 5/11/16, effective 6/15/16; ARC 7747C, IAB 4/3/24, effective 5/8/24]

[Filed emergency 10/24/90—published 11/14/90, effective 10/24/90]

[Filed emergency 1/10/91—published 2/6/91, effective 1/10/91]

[Filed 5/9/91, Notices 11/14/90, 2/20/91—published 5/29/91, effective 7/3/91]

[Filed 5/27/93, Notice 3/17/93—published 6/23/93, effective 7/28/93]

[Filed 1/11/95, Notice 11/23/94—published 2/1/95, effective 3/8/95]

[Filed 11/1/95, Notice 9/27/95—published 11/22/95, effective 12/27/95]

[Filed 10/30/96, Notice 9/25/96—published 11/20/96, effective 12/25/96]

[Filed 6/19/02, Notice 4/17/02—published 7/10/02, effective 8/14/02]

[Filed emergency 3/21/03—published 4/16/03, effective 3/21/03]

[Filed emergency 6/15/05 after Notice 5/11/05—published 7/6/05, effective 7/1/05]

[Filed 10/11/06, Notice 8/30/06—published 11/8/06, effective 12/13/06]

[Filed 12/12/07, Notice 11/7/07—published 1/2/08, effective 2/6/08]

[Filed ARC 7902B (Notice ARC 7721B, IAB 4/22/09), IAB 7/1/09, effective 8/5/09]

[Filed Emergency ARC 9954B, IAB 1/11/12, effective 1/30/12]

[Filed ARC 0031C (Notice ARC 9955B, IAB 1/11/12), IAB 3/7/12, effective 4/11/12]

[Filed ARC 1714C (Notice ARC 1601C, IAB 9/3/14), IAB 11/12/14, effective 12/17/14]

[Filed Emergency ARC 2071C, IAB 8/5/15, effective 7/14/15]

[Filed ARC 2337C (Notice ARC 2070C, IAB 8/5/15), IAB 1/6/16, effective 2/10/16]

[Filed ARC 2530C (Notice ARC 2451C, IAB 3/16/16), IAB 5/11/16, effective 6/15/16]

[Filed ARC 2986C (Notice ARC 2878C, IAB 1/4/17), IAB 3/15/17, effective 4/19/17]

[Filed ARC 3689C (Notice ARC 3532C, IAB 1/3/18), IAB 3/14/18, effective 4/18/18]

[Filed ARC 3840C (Notice ARC 3700C, IAB 3/28/18), IAB 6/6/18, effective 7/11/18]

[Filed ARC 4401C (Notice ARC 4256C, IAB 1/30/19), IAB 4/10/19, effective 5/15/19]  
[Filed ARC 4586C (Notice ARC 4476C, IAB 6/5/19), IAB 7/31/19, effective 9/4/19]  
[Filed ARC 4986C (Notice ARC 4836C, IAB 1/1/20), IAB 3/11/20, effective 4/15/20]  
[Filed ARC 5018C (Notice ARC 4895C, IAB 2/12/20), IAB 4/8/20, effective 5/13/20]  
[Filed ARC 5495C (Notice ARC 5384C, IAB 1/13/21), IAB 3/10/21, effective 4/14/21]  
[Filed ARC 5547C (Notice ARC 5411C, IAB 2/10/21), IAB 4/7/21, effective 5/12/21]  
[Filed ARC 5942C (Notice ARC 5804C, IAB 7/28/21), IAB 10/6/21, effective 11/10/21]  
[Filed ARC 6168C (Notice ARC 6065C, IAB 12/1/21), IAB 2/9/22, effective 3/16/22]  
[Filed ARC 6307C (Notice ARC 6207C, IAB 2/23/22), IAB 5/4/22, effective 6/8/22]  
[Filed ARC 6706C (Notice ARC 6519C, IAB 9/21/22), IAB 11/30/22, effective 1/4/23]  
[Filed ARC 6970C (Notice ARC 6822C, IAB 1/11/23), IAB 4/5/23, effective 5/10/23]  
[Editorial change: IAC Supplement 7/26/23]  
[Editorial change: IAC Supplement 11/29/23]  
[Filed ARC 7747C (Notice ARC 7491C, IAB 1/10/24), IAB 4/3/24, effective 5/8/24]  
[Filed ARC 8055C (Notice ARC 7745C, IAB 4/3/24), IAB 6/12/24, effective 7/17/24]



CHAPTERS 608 and 609

Reserved

CHAPTER 610

RELEASE OF COMPUTERIZED DRIVER'S LICENSE  
AND NONOPERATOR'S IDENTIFICATION CARD RECORDS

[Appeared as Ch 14, Department of Public Safety, July 1974 IDR Supplement.]

[Prior to 6/3/87, Transportation Department[820]—(07,C) Ch 15]

Rescinded **ARC 6060C**, IAB 12/1/21, effective 1/5/22

CHAPTER 611

DRIVER'S PRIVACY PROTECTION—DRIVER'S LICENSE  
AND NONOPERATOR'S IDENTIFICATION CARD

Rescinded **ARC 6060C**, IAB 12/1/21, effective 1/5/22

CHAPTERS 612 to 614

Reserved



CHAPTER 615  
SANCTIONS

[Prior to 6/3/87, Transportation Department[820]—(07,C) Ch 6]

**761—615.1(321) Definitions.** The definitions in 761—600.1(321) apply to this chapter. In addition:

“*Accident free*” as used in Iowa Code section 321.180B means the driver has not been involved in a contributive accident. “*Involvement in a motor vehicle accident*” as used in Iowa Code section 321.180B means involvement in a contributive accident.

“*Contributive accident*” or “*contributed to an accident*” means the driver was involved in an accident for which there is evidence in departmental records that the driver performed an act which resulted in or contributed to the accident or failed to perform an act which would have avoided or contributed to the avoidance of the accident.

“*Deny*” or “*denial*” means a rejection of an application for a license or a refusal to issue, renew or reinstate a license.

“*Moving violation*,” unless otherwise provided in this chapter, means any violation of motor vehicle laws except:

1. Violations of equipment standards to be maintained for motor vehicles.
2. Parking violations as defined in Iowa Code section 321.210.
3. Child restraint and safety belt and harness violations under Iowa Code sections 321.445 and 321.446.
4. Violations of registration, weight and dimension laws.
5. Operating with an expired license.
6. Failure to appear.
7. Disturbing the peace with a motor vehicle.
8. Violations of Iowa Code section 321.20B for failure to provide proof of financial liability coverage.

“*Sanction*” means a license denial, cancellation, suspension, revocation, bar or disqualification.

This rule is intended to implement Iowa Code sections 321.1, 321.178, 321.180A, 321.189, 321.194, 321.210, 321.215, 321.445, 321.446 and 321.555.

[ARC 4119C, IAB 11/7/18, effective 12/12/18]

**761—615.2(321) Scope.** This chapter of rules applies to any license, as defined in 761—600.1(321). However:

**615.2(1)** Rules specifically addressing denial, cancellation or disqualification of a commercial driver’s license are found in 761—Chapter 607, “Commercial Driver Licensing.”

**615.2(2)** Rules implementing Iowa Code chapter 321J are found in 761—Chapter 620, “OWI and Implied Consent.”

**615.2(3)** Rules implementing Iowa Code chapter 321A are found in 761—Chapter 640, “Financial Responsibility.”

This rule is intended to implement Iowa Code chapters 321, 321A and 321J.

**761—615.3(17A) Information and address.** Applications, forms and information concerning license sanctions are available at any driver’s license service center. Assistance is also available by mail from the Motor Vehicle Division, Iowa Department of Transportation, P.O. Box 9204, Des Moines, Iowa 50306-9204; in person at 6310 SE Convenience Blvd., Ankeny, Iowa; by telephone at (515)244-8725; by facsimile at (515)239-1837; or on the department’s website at [www.iowadot.gov](http://www.iowadot.gov).

This rule is intended to implement Iowa Code section 17A.3.

[ARC 4119C, IAB 11/7/18, effective 12/12/18; ARC 5496C, IAB 3/10/21, effective 4/14/21; Editorial change: IAC Supplement 12/28/22]

**761—615.4(321) Denial for incapability.**

**615.4(1)** A person who has a valid Iowa license that would otherwise be suspended for incapability shall, in lieu of a suspension, be denied further licensing if there is less than 30 days’ validity on the license.

*a.* The denial shall be effective when the license is no longer valid.

*b.* The license shall be surrendered to the department. The department shall issue a temporary driving permit which allows the person to drive until the effective date of the denial.

**615.4(2)** If a person who is denied licensing for incapability does not have a valid Iowa license, the department may refuse orally to issue a license, effective immediately, or may deny licensing in writing, effective on the date the denial notice is served.

This rule is intended to implement Iowa Code sections 321.177 and 321.210.

**761—615.5 and 615.6** Reserved.

**761—615.7(321) Cancellations.**

**615.7(1)** The department shall cancel the license of an unmarried minor upon receipt of a written withdrawal of consent from the person who consented to the minor's application. The department shall also cancel a minor's license upon receipt of evidence of the death of the person who consented to the minor's application.

**615.7(2)** The department shall cancel a motorized bicycle license when the licensee is convicted of one moving violation. Reapplication may be made 30 days after the date of cancellation.

**615.7(3)** The department may cancel a license when the person was not entitled or is no longer entitled to a license, failed to give correct and required information, or committed fraud in applying.

**615.7(4)** A cancellation shall begin ten days after the department's notice of cancellation is served.

This rule is intended to implement Iowa Code sections 321.184, 321.185, 321.189, 321.201 and 321.215.

**761—615.8** Reserved.

**761—615.9(321) Habitual offender.**

**615.9(1)** The department shall declare a person to be a habitual offender under Iowa Code section 321.555(1) in accordance with the following point system:

*a.* Points shall be assigned to convictions as follows:

| <u>Conviction</u>   | <u>Points</u> |
|---|---------------|
| Perjury or the making of a false affidavit or statement under oath to the department of public safety                                   | 2 points      |
| Driving while under suspension, revocation or denial (except Iowa Code chapter 321J)  | 2 points      |
| Driving while under Iowa Code chapter 321J revocation or denial   | 3 points      |
| Driving while barred  | 4 points      |
| Operating a motor vehicle in violation of Iowa Code section 321J.2  | 4 points      |
| An offense punishable as a felony under the motor vehicle laws of Iowa or any felony in the commission of which a motor vehicle is used | 5 points      |
| Failure to stop and leave information or to render aid as required by Iowa Code sections 321.261 and 321.263                            | 5 points      |
| Eluding or attempting to elude a pursuing law enforcement vehicle in violation of Iowa Code section 321.279                             | 5 points      |
| Serious injury by a vehicle in violation of Iowa Code section 707.6A(4)   | 5 points      |
| Manslaughter resulting from the operation of a motor vehicle  | 6 points      |

*b.* Based on the points accumulated, the person shall be barred from operating a motor vehicle on the highways of this state as follows:

| <u>Points</u> | <u>Length of bar</u> |
|---------------|----------------------|
| 6 – 7         | 2 years              |
| 8 – 9         | 3 years              |
| 10 – 12       | 4 years              |
| 13 – 15       | 5 years              |
| 16+           | 6 years              |

**615.9(2)** A person declared to be a habitual offender under Iowa Code subsection 321.555(2) shall be barred from operating a motor vehicle on the highways of this state for one year.

**615.9(3)** A person declared to be a habitual offender under Iowa Code section 321.560 shall be barred from operating a motor vehicle on the highways of this state beginning on the date the previous bar expires.

This rule is intended to implement Iowa Code sections 321.555, 321.556 and 321.560.

[ARC 4119C, IAB 11/7/18, effective 12/12/18]

**761—615.10** Reserved.

**761—615.11(321) Periods of suspension or revocation.**

**615.11(1) Length.** The department shall not suspend or revoke a person's license for less than 30 days nor for more than one year unless a statute specifies or permits a different period of suspension or revocation.

**615.11(2) Extension of suspension or revocation.** The department shall extend the period of license suspension or revocation for an additional like period or for one year, whichever period is shorter, when the person is convicted of operating a motor vehicle while the person's license is suspended or revoked, unless a statutory exception applies. If the person's driving record does not indicate what the original grounds for suspension or revocation were, the period of license suspension or revocation shall not exceed six months.

This rule is intended to implement Iowa Code sections 321.212 and 321.218.

[ARC 4119C, IAB 11/7/18, effective 12/12/18]

**761—615.12(321) Suspension of a habitually reckless or negligent driver.**

**615.12(1)** The department may suspend a person's license if the person is a habitually reckless or negligent driver of a motor vehicle. "Habitually reckless or negligent driver" means a person who has accumulated a combination of three or more contributive accidents and convictions for moving violations or three or more contributive accidents within a 12-month period.

**615.12(2)** In this rule, speeding violations specified in Iowa Code section 321.210(2)"d" and violations under Iowa Code section 321.276 are not included.

**615.12(3)** The suspension period shall be at least 60 days.

This rule is intended to implement Iowa Code section 321.210.

[ARC 4119C, IAB 11/7/18, effective 12/12/18]

**761—615.13(321) Suspension of a habitual violator.**

**615.13(1)** The department may suspend a person's license when the person is a habitual violator of the traffic laws. "Habitual violator" means that the person has been convicted of three or more moving violations committed within a 12-month period.

**615.13(2)** The minimum suspension periods shall be as follows unless reduced by a driver's license hearing officer based on mitigating circumstances:

|                                    |          |
|------------------------------------|----------|
| 3 convictions in 12 months         | 90 days  |
| 4 convictions in 12 months         | 120 days |
| 5 convictions in 12 months         | 150 days |
| 6 convictions in 12 months         | 180 days |
| 7 or more convictions in 12 months | 1 year   |

**615.13(3)** In this rule, speeding violations specified in Iowa Code section 321.210(2)"d" and violations under Iowa Code section 321.276 are not included.

This rule is intended to implement Iowa Code section 321.210.

[ARC 4119C, IAB 11/7/18, effective 12/12/18]

**761—615.14(321) Suspension for incapability.** The department may suspend a person's license when the person is incapable of safely operating a motor vehicle.

**615.14(1)** Suspension for incapability may be based on one or more of the following:

*a.* Receipt of a medical report stating that the person is not physically or mentally capable of safely operating a motor vehicle.

*b.* Failure of the person to appear for a required reexamination or failure to submit a required medical report within the specified time.

*c.* Ineligibility for licensing under Iowa Code sections 321.177(4) to 321.177(7).

**615.14(2)** The suspension period shall be indefinite but shall be terminated when the department receives satisfactory evidence that the licensee has been restored to capability.

**615.14(3)** A person whose license has been suspended for incapability may be eligible for a special noncommercial instruction permit under rule 761—602.21(321).

This rule is intended to implement Iowa Code sections 321.177, 321.210, and 321.212.

[ARC 4119C, IAB 11/7/18, effective 12/12/18]

**761—615.15(321) Suspension for unlawful use of a license.**

**615.15(1)** The department may suspend a person’s license when the person has been convicted of unlawful or fraudulent use of the license or if the department has received other evidence that the person has violated Iowa Code section 321.216, 321.216A, 321.216B or 321.216C.

**615.15(2)** The suspension period shall be at least 30 days.

**615.15(3)** A suspension for a violation of Iowa Code section 321.216B shall not exceed six months.

This rule is intended to implement Iowa Code sections 321.210, 321.212, 321.216, 321.216A, 321.216B and 321.216C.

[ARC 5496C, IAB 3/10/21, effective 4/14/21]

**761—615.16(321) Suspension for out-of-state offense.** The department may suspend a person’s license when the department is notified by another state that the person committed an offense in that state which, if committed in Iowa, would be grounds for suspension. The notice may indicate either a conviction or a final administrative decision. The period of the suspension shall be the same as if the offense had occurred in Iowa.

This rule is intended to implement Iowa Code sections 321.205 and 321.210.

**761—615.17(321) Suspension for a serious violation.**

**615.17(1)** The department may suspend a person’s license when the person has committed a serious violation of the motor vehicle laws.

**615.17(2)** “Serious violation” means that:

*a.* The person’s conviction for a moving violation was accompanied by a written report from the arresting officer, the prosecuting attorney or the court indicating that the violation was unusually serious. The suspension period shall be at least 60 days.

*b.* The person was convicted of a moving violation which contributed to a fatal motor vehicle accident. The suspension period shall be at least 120 days.

*c.* The person was convicted for speeding 25 miles per hour (mph) or more above the legal limit. The minimum suspension period shall be as follows unless reduced by a driver’s license hearing officer based on mitigating circumstances:

|                                     |          |
|-------------------------------------|----------|
| 25 mph over the legal limit         | 60 days  |
| 26 mph over the legal limit         | 65 days  |
| 27 mph over the legal limit         | 70 days  |
| 28 mph over the legal limit         | 75 days  |
| 29 mph over the legal limit         | 80 days  |
| 30 mph over the legal limit         | 90 days  |
| 31 mph over the legal limit         | 100 days |
| 32 mph over the legal limit         | 110 days |
| 33 mph over the legal limit         | 120 days |
| 34 mph over the legal limit         | 130 days |
| 35 mph over the legal limit         | 140 days |
| 36 mph over the legal limit         | 150 days |
| 37 mph over the legal limit         | 160 days |
| 38 mph over the legal limit         | 170 days |
| 39 mph over the legal limit         | 180 days |
| 40 mph over the legal limit         | 190 days |
| 41 mph over the legal limit         | 210 days |
| 42 mph over the legal limit         | 230 days |
| 43 mph over the legal limit         | 250 days |
| 44 mph over the legal limit         | 270 days |
| 45 mph over the legal limit         | 290 days |
| 46 mph over the legal limit         | 310 days |
| 47 mph over the legal limit         | 330 days |
| 48 mph over the legal limit         | 350 days |
| 49 mph or more over the legal limit | one year |

*d.* The person was convicted of violating Iowa Code section 321.372(3) or a similar ordinance of any political subdivision. The suspension period shall be:

(1) 30 days for a first conviction unless otherwise provided in subparagraph 615.43(1)“a”(4).

- (2) 90 days for a second conviction.
- (3) 180 days for a third or subsequent conviction.

e. The person was convicted of violating Iowa Code section 321.323A or a similar ordinance of any political subdivision. The suspension period shall be:

- (1) 90 days for a violation causing property damage only to the property of another person.
- (2) 180 days for a violation causing bodily injury to another person.
- (3) One year for a violation causing death.

This rule is intended to implement Iowa Code sections 321.210, 321.323A, 321.372 and 321.491.

[ARC 0250C, IAB 8/8/12, effective 9/12/12; ARC 0309C, IAB 9/5/12, effective 8/15/12; ARC 4119C, IAB 11/7/18, effective 12/12/18; ARC 4758C, IAB 11/6/19, effective 12/11/19; ARC 5017C, IAB 4/8/20, effective 5/13/20]

#### **761—615.18(321) Suspension under the nonresident violator compact.**

**615.18(1)** The department may suspend a person's license when a report is received from another state under the nonresident violator compact that an Iowa licensee has failed to comply with the terms of a traffic citation.

**615.18(2)** The suspension shall begin 30 days after the department's notice of suspension is served.

**615.18(3)** The suspension shall continue until the department issues a notice terminating the suspension. The department shall terminate the suspension when it receives evidence of compliance with the terms of the citation.

This rule is intended to implement Iowa Code sections 321.210 and 321.513.

**761—615.19(321) Suspension for a charge of vehicular homicide.** In accordance with Iowa Code section 321.210D, the department shall suspend a person's license when the department receives notice from the clerk of the district court that an indictment or information has been filed charging the person with homicide by vehicle under Iowa Code section 707.6A, subsection 1 or 2. The suspension shall begin ten days after the department's suspension notice is issued.

This rule is intended to implement Iowa Code section 321.210D.

**761—615.20(321) Suspension for moving violation during driving probation.** The department may suspend the license of a person convicted of a moving violation pursuant to Iowa Code section 321.210C. The suspension period shall be equal in duration to the original period of suspension, revocation or bar, or for one year, whichever is the shorter period.

This rule is intended to implement Iowa Code section 321.210C.

[ARC 4119C, IAB 11/7/18, effective 12/12/18]

#### **761—615.21(321) Suspension of a minor's school license and minor's restricted license.**

**615.21(1)** *Suspension of a minor's school license.*

a. The department may suspend a minor's school license upon receiving notice of the licensee's conviction for one moving violation or evidence of one or more accidents chargeable to the licensee.

b. The department may also suspend a minor's school license when the department receives written notice from a peace officer, parent, custodian or guardian, school superintendent, superintendent's designee or nonpublic school authority that the licensee has violated the restrictions of the license.

c. The suspension period under this subrule shall be at least 30 days.

**615.21(2)** *Suspension of a minor's restricted license.* The department may suspend a minor's restricted license upon receiving notice of the licensee's conviction for one moving violation. The suspension period shall be at least 30 days.

This rule is intended to implement Iowa Code sections 321.178 and 321.194.

[ARC 5496C, IAB 3/10/21, effective 4/14/21]

#### **761—615.22(321) Suspension for nonpayment of fine, penalty, surcharge or court costs.**

**615.22(1)** The department shall suspend a person's privilege to operate motor vehicles in Iowa when the department is notified by a clerk of the district court that the person has been convicted of violating a law regulating the operation of motor vehicles, that the person has failed to pay the fine, penalty, surcharge or court costs arising out of the conviction, and that 60 days have elapsed since the person was mailed a notice of nonpayment from the clerk of the district court.

a. The suspension period shall begin 30 days after the notice of suspension is served.

b. The suspension shall continue until the department has issued a notice terminating the suspension. The department shall terminate the suspension when it receives evidence that all appropriate payments have been made.

c. An informal settlement, hearing or appeal to contest the suspension shall be limited to a determination of whether the facts required by Iowa Code section 321.210A and this subrule are true. The merits of the conviction shall not be considered.

**615.22(2)** Reserved.

This rule is intended to implement Iowa Code section 321.210A.

[ARC 0592C, IAB 2/6/13, effective 3/13/13; ARC 4119C, IAB 11/7/18, effective 12/12/18]

**761—615.23(321) Suspensions for juveniles.**

**615.23(1)** *Suspension for juveniles adjudicated delinquent for certain offenses.*

a. Pursuant to Iowa Code section 321.213A, the department shall suspend the license of a person for one year upon receipt of an adjudication and dispositional order from the clerk of the juvenile court.

b. The department may issue to a person suspended under this subrule a temporary restricted license in accordance with rule 761—615.45(321) if issuance is permitted under Iowa Code section 321.215 and the person is otherwise eligible for the license. To obtain a temporary restricted license that is valid for educational purposes, the applicant must meet the requirements for issuance of a minor's school license under Iowa Code section 321.194 and rule 761—602.26(321).

**615.23(2)** *Suspension for juvenile's failure to attend school.*

a. The department shall suspend the driver's license of a person under the age of 18 upon receipt of notification from the appropriate school authority that the person does not attend school.

b. "School" means a public school, an accredited nonpublic school, competent private instruction in accordance with the provisions of Iowa Code chapter 299A, an alternative school or adult education classes.

c. "Appropriate school authority" means the superintendent of a public school or the chief administrator of an accredited nonpublic school, an alternative school or adult education.

d. The suspension shall continue until the person reaches the age of 18 or until the department receives notification from the appropriate school authority that the person is attending school.

e. The department may issue to the person a minor's restricted license in accordance with Iowa Code section 321.178 and rule 761—602.25(321) if the person is eligible for the license.

This rule is intended to implement Iowa Code sections 232.52(2), 299.1B, 321.213, 321.213A, 321.213B and 321.215.

[ARC 4119C, IAB 11/7/18, effective 12/12/18]

**761—615.24(252J) Suspension upon receipt of a certificate of noncompliance.**

**615.24(1)** *From child support recovery unit.*

a. The department shall suspend a person's Iowa-issued driver's license upon receipt of a certificate of noncompliance from the child support recovery unit.

b. The suspension shall begin 30 days after the department's notice of suspension is served.

c. The suspension shall continue until receipt of a withdrawal of the certificate of noncompliance from the child support recovery unit.

d. The filing of an application pursuant to Iowa Code section 252J.9 stays the suspension pending the outcome of the district court hearing.

**615.24(2)** *From college student aid commission.* Rescinded IAB 11/6/19, effective 12/11/19.

**615.24(3)** *From department of revenue.* Rescinded IAB 2/8/12, effective 3/14/12.

This rule is intended to implement Iowa Code sections 252J.1, 252J.8 and 252J.9.

[ARC 7902B, IAB 7/1/09, effective 8/5/09; ARC 9991B, IAB 2/8/12, effective 3/14/12; ARC 4758C, IAB 11/6/19, effective 12/11/19]

**761—615.25** Reserved.

**761—615.26(321) Suspension for violation of a license restriction.** The department may suspend a person's license when the department receives satisfactory evidence of a violation of a restriction imposed on the license. The suspension period shall be at least 30 days.

This rule is intended to implement Iowa Code section 321.193.

[ARC 5496C, IAB 3/10/21, effective 4/14/21]

**761—615.27 and 615.28** Reserved.

**761—615.29(321) Mandatory revocation.**

**615.29(1)** The department shall revoke a person's license upon receipt of a record of the person's conviction for an offense listed under Iowa Code section 321.209.

**615.29(2)** The department shall revoke a person's license under Iowa Code subsection 321.209(2) upon receipt of a record of the person's conviction for a felony:

- a. Which provides specific factual findings by the court that a motor vehicle was used in the commission of the offense,
- b. Which is accompanied by information from the prosecuting attorney indicating that a motor vehicle was used in the commission of the crime, or
- c. Where the elements of the offense actually required the use of a motor vehicle.

**615.29(3)** The revocation period shall be at least one year except:

- a. The revocation period for two convictions of reckless driving shall be at least five days and not more than 30 days.
- b. The revocation period for a first offense for drag racing shall be six months if the violation did not result in personal injury or property damage.

This rule is intended to implement Iowa Code sections 321.209, 321.212, 321.261 and 707.6A.

[ARC 4119C, IAB 11/7/18, effective 12/12/18; ARC 4758C, IAB 11/6/19, effective 12/11/19]

**761—615.30(321) Revocation for out-of-state offense.** The department may revoke an Iowa resident's license when the department is notified by another state that the person committed an offense in that state which, if committed in Iowa, would be grounds for revocation. The notice may indicate either a conviction or a final administrative decision. The period of the revocation shall be the same as if the offense had occurred in Iowa.

This rule is intended to implement Iowa Code section 321.205.

[ARC 4119C, IAB 11/7/18, effective 12/12/18]

**761—615.31** Reserved.

**761—615.32(321) Extension of suspension or revocation period under Iowa Code chapter 321J.** Anything in rule 761—615.11(321) notwithstanding, the department shall extend the period of license suspension or revocation for an additional like period when the person is convicted of operating a motor vehicle while the person's license is suspended or revoked under Iowa Code chapter 321J.

This rule is intended to implement Iowa Code section 321J.21.

[ARC 4119C, IAB 11/7/18, effective 12/12/18]

**761—615.33(321) Revocation of a minor's license.**

**615.33(1)** The department shall revoke a minor's restricted license upon receiving a record of the minor's conviction for two or more moving violations.

**615.33(2)** The department shall revoke a minor's school license upon receiving a record of the minor's conviction for two or more moving violations.

This rule is intended to implement Iowa Code subsection 321.178(2) and section 321.194.

**761—615.34 and 615.35** Reserved.

**761—615.36(321) Effective date of suspension, revocation, disqualification or bar.** Unless otherwise specified by statute or rule, a suspension, revocation, disqualification or bar shall begin 30 days after the department's notice of suspension, revocation, disqualification or bar is served.

This rule is intended to implement Iowa Code sections 321.208, 321.209, 321.210, and 321.556.

**761—615.37(321) Service of notice.**

**615.37(1)** The department shall send a notice of denial, cancellation, suspension, revocation, disqualification or bar by first-class mail to the person's mailing address as shown on departmental records.

**615.37(2)** In lieu of service by mail, the notice may be delivered by a peace officer, a departmental employee, or any person over 18 years of age.

- a. The person serving the notice shall prepare a certificate of personal service certifying delivery, specifying the name of the receiver, the address and the date, or certifying nondelivery.

b. The department shall pay fees for personal service of notice by a sheriff as specified in Iowa Code section 331.655. The department may also contract for personal service of notice when the department determines that it is in the best interests of the state.

**615.37(3)** The denial, cancellation, suspension, revocation, disqualification or bar shall become effective on the date specified in the notice.

**615.37(4)** The department may prepare an affidavit of mailing verifying the fact that a notice was mailed by first-class mail. To verify the mailing of a notice, the department may use its records in conjunction with U.S. Postal Service records available to the department. The department's affidavit of mailing may be attested to and certified in accordance with Iowa Code section 622.1.

This rule is intended to implement Iowa Code sections 321.16, 321.211, 321.211A, 321.556, 321J.9, 321J.12, and 331.655.

[ARC 3027C, IAB 4/12/17, effective 5/17/17]

#### **761—615.38(17A,321) Hearing and appeal process.**

**615.38(1)** *Applicability.* This rule applies to:

a. License denials, cancellations and suspensions under Iowa Code sections 321.177 to 321.215 and 321A.4 to 321A.11 except suspensions under Iowa Code sections 321.213A and 321.213B.

b. License suspensions and revocations under Iowa Code sections 321.218 and 321J.21.

c. License revocations under Iowa Code sections 321.193 and 321.205.

d. Disqualifications from operating a commercial motor vehicle under Iowa Code section 321.208.

e. License bars under Iowa Code section 321.556.

**615.38(2)** *Submission of request or appeal.*

a. A person subject to a sanction listed in subrule 615.38(1) may contest the action by following the provisions of 761—Chapter 13 as supplemented by this rule.

b. A request for an informal settlement, a request for a contested case hearing, or an appeal of a presiding officer's decision shall be submitted to the director of the motor vehicle division at the address in rule 761—615.3(17A).

c. The request or appeal shall include the person's name, date of birth, driver's license or permit number, complete address and telephone number, and the name, address and telephone number of the person's attorney, if any.

**615.38(3)** *Informal settlement or hearing.*

a. The person may request an informal settlement. Following an unsuccessful informal settlement procedure, or instead of that procedure, the person may request a contested case hearing.

b. Notwithstanding paragraph 615.38(3) "a," a request received from a person who has participated in a driver improvement interview on the same matter shall be deemed a request for a contested case hearing.

c. A request for an informal settlement or a request for a contested case hearing shall be deemed timely submitted if it is delivered to the director of the motor vehicle division or postmarked within the time period specified in the department's notice of the sanction.

(1) Unless a longer time period is specified in the notice or another time period is specified by statute or rule, the time period shall be 20 days after the notice is served.

(2) If the department fails to specify a time period in the notice, the request may be submitted at any time.

**615.38(4)** *Appeal.* An appeal of a presiding officer's decision shall be submitted in accordance with 761—13.7(17A).

**615.38(5)** *Stay of sanction.*

a. When the department receives a properly submitted, timely request for an informal settlement, request for a contested case hearing or appeal of a presiding officer's proposed decision regarding a sanction listed in subrule 615.38(1), it shall, after a review of its records to determine eligibility, stay (stop) the sanction pending the outcome of the settlement, hearing or appeal unless prohibited by statute or rule or unless otherwise specified by the requester/appellant.

(1) If the stay is granted, the department shall issue and send to the person a notice granting the stay. The stay is effective on the date of issuance. The notice allows the person to drive while the sanction is stayed if the license is valid and no other sanction is in effect.

(2) A person whose stay authorizes driving privileges shall carry the notice of stay at all times while driving.

b. Of the sanctions listed in subrule 615.38(1), the department shall not stay the following, and the person's driving privileges do not continue:

(1) A suspension for incapability.

(2) A denial.

- (3) A disqualification from operating a commercial motor vehicle.
- (4) A suspension under Iowa Code section 321.180B.
- (5) A suspension or revocation under Iowa Code section 321.218 or 321J.21.

This rule is intended to implement Iowa Code chapter 17A and sections 321.177 to 321.215, 321.218, 321.556, 321A.4 to 321A.11, and 321J.21.

[ARC 4119C, IAB 11/7/18, effective 12/12/18; ARC 5496C, IAB 3/10/21, effective 4/14/21; Editorial change: IAC Supplement 12/28/22]

**761—615.39(321) Surrender of license.** A person whose Iowa license has been canceled, suspended, revoked or barred or who has been disqualified from operating a commercial motor vehicle shall surrender the license to the designated representative of the department on or before the effective date of the sanction.

This rule is intended to implement Iowa Code sections 321.201, 321.208, 321.212, 321.216, 321.556, and 321A.31.

**761—615.40(321) License reinstatement or reissue.** The department may reinstate the license when the denial, cancellation, suspension, revocation, bar or disqualification has ended if the person has:

**615.40(1)** Filed proof of financial responsibility under Iowa Code chapter 321A, when required, for all vehicles to be operated. The class of license issued will depend on the examinations passed and other qualifications of the applicant. Regardless of the class of license issued, the license shall be valid only for the operation of the motor vehicles covered under the proof of financial responsibility filed by the applicant.

**615.40(2)** Paid the civil penalty when required by Iowa Code section 321J.17.

**615.40(3)** Complied with the specific instructions given in the department's notice terminating the sanction.

**615.40(4)** Successfully completed the required driver license examination.

**615.40(5)** Paid the reinstatement fee when required. The reinstatement fee is specified in Iowa Code section 321.191.

**615.40(6)** Paid the appropriate license fee or duplicate license fee. These fees are specified in Iowa Code sections 321.191 and 321.195.

This rule is intended to implement Iowa Code sections 321.186, 321.191, 321.195, 321.208, 321.212, 321A.17 and 321J.17.

[ARC 7902B, IAB 7/1/09, effective 8/5/09; ARC 4119C, IAB 11/7/18, effective 12/12/18; ARC 5496C, IAB 3/10/21, effective 4/14/21]

**761—615.41(321) Investigation of convictions based on fraud.** A person requesting investigation of fraudulent use of a person's name or other fraudulent identification that resulted in a record of conviction for a scheduled violation under Iowa Code chapter 321 and listed in Iowa Code section 805.8A may submit a written application to the department using Form 420049. The department shall review the application and may investigate, if appropriate, as required by Iowa Code section 321.200A. Form 420049 may be obtained by contacting the Bureau of Investigation and Identity Protection, Iowa Department of Transportation, 6310 SE Convenience Blvd., Ankeny, Iowa; or on the department's website.

This rule is intended to implement Iowa Code section 321.200A.

[ARC 2424C, IAB 3/2/16, effective 4/6/16; ARC 4119C, IAB 11/7/18, effective 12/12/18]

**761—615.42(321) Remedial driver improvement action under Iowa Code section 321.180B.**

**615.42(1)** The department shall require remedial driver improvement action when a person holding an instruction permit, an intermediate license or a full-privilege driver's license under Iowa Code section 321.180B is convicted of a moving violation or has a contributive accident and the violation or accident occurred during the term of the instruction permit or intermediate license.

**615.42(2)** Completion of remedial driver improvement action means any or all of the following as determined by the department: suspension, safety advisory letter, additional restriction(s), vision screening, knowledge examination, and driving examination.

**615.42(3)** A suspension period under this rule shall be for no less than 30 days nor longer than one year. A person whose driving privilege has been suspended under this rule is not eligible for a temporary restricted license.

**615.42(4)** Remedial driver improvement action or suspension under this rule terminates when a person attains the age of 18.

This rule is intended to implement Iowa Code section 321.180B.

[ARC 7902B, IAB 7/1/09, effective 8/5/09]

**761—615.43(321) Driver improvement program.**

**615.43(1)** *When required.*

*a.* In lieu of suspension, the department may require the following persons to attend and successfully complete, at the person's own expense, a driver improvement program approved by the department:

- (1) A habitual violator.
- (2) A person who is convicted for speeding at least 25 but not more than 29 miles per hour over the legal limit.
- (3) A person whose license is subject to suspension under Iowa Code section 321.210C.
- (4) A person who is convicted of a first offense violation of Iowa Code section 321.372(3) or a similar ordinance of any political subdivision.

*b.* However, a person shall not be assigned to a driver improvement program more than once within a two-year period.

**615.43(2) Scheduling.** The department shall forward the person's contact information to the approved driver improvement program provider nearest the person's last known address. The provider will schedule the person's attendance at the provider's next available program opening.

*a.* One request for rescheduling may be granted by the provider if the program begins within 30 days of the originally scheduled date and if space is available.

*b.* A request to attend a program in another state may be granted if the curriculum is approved by the department.

**615.43(3) Probation.** When a person is required to attend and successfully complete a driver improvement program, the department shall also require the person to complete a probationary driving period not to exceed one year. One conviction for a moving violation committed during probation may result in suspension of the person's license. The suspension period shall be at least 90 days, unless reduced by a driver's license hearing officer based on mitigating circumstances.

**615.43(4) Failure to attend.** The department shall suspend the license of a person who is required to attend a driver improvement program and who does not attend, or does not successfully complete, the program. The suspension period shall be for the length of the original underlying suspension.

This rule is intended to implement Iowa Code sections 321.210 and 321.210C.

[ARC 5017C, IAB 4/8/20, effective 5/13/20; ARC 5496C, IAB 3/10/21, effective 4/14/21]

**761—615.44(321) Driver improvement interview.** Rescinded ARC 5496C, IAB 3/10/21, effective 4/14/21.

**761—615.45(321) Temporary restricted license (work permit).**

**615.45(1) Ineligibility.** The department shall not issue a temporary restricted license under Iowa Code section 321.215 to an applicant:

- a.* Whose license has been denied or canceled.
- b.* Whose license has been suspended for incapability.
- c.* Whose license has been suspended for noncompliance with the financial responsibility law.
- d.* Whose minor's school license or minor's restricted license has been suspended or revoked.
- e.* Rescinded IAB 10/6/21, effective 11/10/21.
- f.* Whose license has been mandatorily revoked under Iowa Code section 321.209, subsections 1 to 4 or subsection 7, or for a second or subsequent conviction for drag racing.
- g.* Whose license is barred under Iowa Code section 321.560 unless the applicant is declared to be a habitual offender under Iowa Code section 321.555(1) "c" or 321.555(2).
- h.* Whose license has been suspended due to receipt of a certificate of noncompliance from the child support recovery unit.
- i.* Whose license has been suspended for a charge of vehicular homicide.
- j.* Whose license has been suspended under Iowa Code section 321.180B(3).

**615.45(2) Application.**

*a.* To obtain a temporary restricted license, an applicant shall complete and submit Form 430100 and any supporting documentation to the motor vehicle division at the address in rule 761—615.3(17A).

*b.* A temporary restricted license issued for employment may include permission for the licensee to transport dependent children to and from a location for child care when that activity is essential to continuation of the licensee's employment.

**615.45(3) Statements.** A person applying for a temporary restricted license shall submit all of the following statements that apply to the person's situation. Each statement shall explain the need for the license and shall list specific places and times for the activity which can be verified by the department.

*a.* A statement from the applicant.

b. A statement from the applicant's employer unless the applicant is self-employed including, when applicable, verification that the applicant's use of a child care facility is essential to the applicant's continued employment.

c. A statement from the health care provider if the applicant or the applicant's dependent requires continuing health care.

d. A statement from the educational institution in which the applicant is enrolled.

e. A statement from the substance abuse treatment program in which the applicant is participating.

f. A copy of the court order for community service and a statement describing the assigned community service from the responsible supervisor.

g. A statement from the child care provider.

**615.45(4) Additional requirements.** An applicant for a temporary restricted license shall also:

a. Provide a description of all motor vehicles to be operated under the temporary restricted license.

b. File proof of financial responsibility under Iowa Code chapter 321A, if required, for all motor vehicles to be operated under the temporary restricted license.

c. Pay the civil penalty when required by Iowa Code section 321J.17.

**615.45(5) Issuance and restrictions.**

a. When the application is approved and all requirements are met, the applicant shall be notified by the department. The applicant shall pass the appropriate examination for the type of vehicle to be operated under the temporary restricted license. An Iowa resident shall also pay the reinstatement and license fees.

b. The department shall determine the restrictions to be imposed by the temporary restricted license. The licensee shall apply to the department in writing with a justification for any requested change in license restrictions.

**615.45(6) Denial.** An applicant who has been denied a temporary restricted license or who contests the license restrictions imposed by the department may contest the decision in accordance with rule 761—615.38(321).

This rule is intended to implement Iowa Code chapter 321A and sections 252J.8, 321.177, 321.178, 321.184, 321.185, 321.186, 321.189, 321.191, 321.193, 321.194, 321.201, 321.205, 321.209, 321.210, 321.210A, 321.212, 321.213A, 321.213B, 321.215, 321.218 as amended by 2021 Iowa Acts, House File 757, section 1, 321.513, 321.560 and 321J.17.

[ARC 4119C, IAB 11/7/18, effective 12/12/18; ARC 4758C, IAB 11/6/19, effective 12/11/19; ARC 5496C, IAB 3/10/21, effective 4/14/21; ARC 5941C, IAB 10/6/21, effective 11/10/21; Editorial change: IAC Supplement 12/28/22]

[Filed emergency 9/13/85—published 10/9/85, effective 9/13/85]

[Filed 11/27/85, Notice 10/9/85—published 12/18/85, effective 1/22/86]

[Filed emergency 6/20/86—published 7/16/86, effective 7/1/86]

[Filed 5/11/87, Notice 3/11/87—published 6/3/87, effective 7/8/87]

[Filed 1/20/88, Notice 12/2/87—published 2/10/88, effective 3/16/88]<sup>o</sup>

[Filed emergency 5/16/88—published 6/15/88, effective 5/16/88]

[Filed 11/3/88, Notice 9/21/88—published 11/30/88, effective 1/4/89]

[Filed 9/21/89, Notice 7/26/89—published 10/18/89, effective 11/22/89]

[Filed emergency 11/30/89—published 12/27/89, effective 12/1/89]

[Filed 12/18/91, Notice 11/13/91—published 1/8/92, effective 2/12/92]

[Filed 11/4/93, Notice 9/29/93—published 11/24/93, effective 12/29/93]

[Filed 1/11/95, Notice 11/23/94—published 2/1/95, effective 3/8/95]

[Filed 11/1/95, Notice 9/27/95—published 11/22/95, effective 12/27/95]

[Filed 10/30/96, Notice 9/25/96—published 11/20/96, effective 12/25/96]

[Filed 1/21/98, Notice 12/17/97—published 2/11/98, effective 3/18/98]

[Filed 10/28/98, Notice 9/23/98—published 11/18/98, effective 12/23/98]

[Filed 4/8/99, Notice 2/10/99—published 5/5/99, effective 7/1/99]

[Filed 2/15/02, Notice 12/26/01—published 3/20/02, effective 4/24/02]

[Filed 6/19/02, Notice 4/17/02—published 7/10/02, effective 8/14/02]

[Filed 10/11/06, Notice 8/30/06—published 11/8/06, effective 12/13/06]

[Filed ARC 7902B (Notice ARC 7721B, IAB 4/22/09), IAB 7/1/09, effective 8/5/09]

[Filed ARC 9991B (Notice ARC 9874B, IAB 11/30/11), IAB 2/8/12, effective 3/14/12]

[Filed ARC 0250C (Notice ARC 0158C, IAB 6/13/12), IAB 8/8/12, effective 9/12/12]

[Filed Emergency After Notice ARC 0309C (Notice ARC 0158C, IAB 6/13/12), IAB 9/5/12, effective 8/15/12]

[Filed ARC 0592C (Notice ARC 0438C, IAB 11/14/12), IAB 2/6/13, effective 3/13/13]

[Filed ARC 2424C (Notice ARC 2344C, IAB 1/6/16), IAB 3/2/16, effective 4/6/16]

[Filed ARC 3027C (Notice ARC 2921C, IAB 2/1/17), IAB 4/12/17, effective 5/17/17]

[Filed ARC 4119C (Notice ARC 3967C, IAB 8/29/18), IAB 11/7/18, effective 12/12/18]

[Filed ARC 4758C (Notice ARC 4625C, IAB 8/28/19), IAB 11/6/19, effective 12/11/19]

[Filed ARC 5017C (Notice ARC 4884C, IAB 1/29/20), IAB 4/8/20, effective 5/13/20]

[Filed ARC 5496C (Notice ARC 5385C, IAB 1/13/21), IAB 3/10/21, effective 4/14/21]

[Filed ARC 5941C (Notice ARC 5858C, IAB 8/11/21), IAB 10/6/21, effective 11/10/21]

[Editorial change: IAC Supplement 12/28/22]

◇ Two or more ARCs

CHAPTERS 616 to 619  
Reserved



CHAPTER 620  
OWI AND IMPLIED CONSENT

[Prior to 6/3/87, Transportation Department[820]—(07,C)Ch 11]

**761—620.1(321J) Definitions.** Rescinded IAB 1/8/92, effective 2/12/92.

**761—620.2(321J) Information and location.** Applications, forms, information, assistance, and answers to questions relating to this chapter are available by mail from the Motor Vehicle Division, Iowa Department of Transportation, P.O. Box 9204, Des Moines, Iowa 50306-9204; in person at 6310 SE Convenience Blvd., Ankeny, Iowa; by telephone at (515)244-8725; or by facsimile at (515)239-1837.

[ARC 4001C, IAB 9/12/18, effective 10/17/18; ARC 4760C, IAB 11/6/19, effective 12/11/19; ARC 5941C, IAB 10/6/21, effective 11/10/21]

**761—620.3(321J) Issuance of temporary restricted license.**

**620.3(1) Eligibility and application.**

*a.* The department may issue a temporary restricted license to a person who is eligible under and for the purposes listed in Iowa Code chapter 321J. The department shall not issue a temporary restricted license to a person who is otherwise ineligible.

*b.* To apply for a temporary restricted license, an applicant shall, at any time before or during the revocation period, submit application Form 430400 to the motor vehicle division. The application form should be furnished by the arresting officer. It may also be obtained upon oral or written request to the motor vehicle division.

**620.3(2) Additional requirements.** A person applying for a temporary restricted license shall also comply with all of the following requirements:

*a.* Provide a description of all motor vehicles operated under the temporary restricted license if the person has no previous operating while intoxicated conviction or revocation. If the person has a second or subsequent operating while intoxicated conviction or revocation, the person shall provide a description of all motor vehicles owned by such person or operated under the temporary restricted license.

*b.* Submit proof of financial responsibility under Iowa Code chapter 321A for all motor vehicles owned or operated under the temporary restricted license.

*c.* Provide certification of installation of an approved ignition interlock device on every motor vehicle operated if the person has no previous operating while intoxicated conviction or revocation. If the person has a second or subsequent operating while intoxicated conviction or revocation, the person shall provide certification of installation of an approved ignition interlock device on every motor vehicle owned by such person or operated under the temporary restricted license.

*d.* Pay the \$200 civil penalty.

**620.3(3) Issuance and restrictions.**

*a.* The department shall not issue the temporary restricted license until the application is approved, all requirements are met, the applicable reinstatement and license fees have been paid, and the applicant has passed the appropriate examination for the type of vehicle to be operated under the temporary restricted license.

*b.* The department shall determine the restrictions to be imposed by the temporary restricted license. The licensee shall apply to the department in writing with a justification for any requested change in license restrictions.

**620.3(4) Denial.** A person who has been denied a temporary restricted license or who contests the restrictions imposed by the department may request an informal settlement conference by submitting a written request to the director of the motor vehicle division. Following an unsuccessful informal settlement or instead of that procedure, the person may request a contested case hearing in accordance with rule 761—620.4(321J).

[ARC 8024B, IAB 8/12/09, effective 7/14/09; ARC 8203B, IAB 10/7/09, effective 11/11/09; ARC 4001C, IAB 9/12/18, effective 10/17/18; ARC 4347C, IAB 3/13/19, effective 4/17/19; ARC 4760C, IAB 11/6/19, effective 12/11/19; ARC 5429C, IAB 2/10/21, effective 3/17/21; ARC 5941C, IAB 10/6/21, effective 11/10/21]

**761—620.4(321J) Hearings and appeals.**

**620.4(1) Contested case hearing.**

*a.* A person may request a contested case hearing by checking the appropriate box on Form 432018 and submitting it to the department or by submitting a written request to the director of the motor vehicle division. The request shall include the person's name, date of birth, driver's license number, complete address and telephone number.

*b.* A request for a hearing to contest the denial of a temporary restricted license or to contest the restrictions may be submitted at any time.

c. A request for a hearing to contest a revocation shall be submitted within ten days after receipt of the revocation notice. The request shall be deemed timely submitted if it is delivered to the director of the motor vehicle division or properly addressed and postmarked within this time period.

d. Failure to timely request a hearing on a revocation is a waiver of the right to a hearing under Iowa Code chapter 321J, and the revocation shall become effective on the date specified in the revocation notice.

e. After a hearing, a written decision will be issued by the presiding officer.

**620.4(2) Appeal.** A decision by a presiding officer shall become the final decision of the department and shall be binding on the department and the person who requested the hearing unless either appeals the decision in accordance with this subrule.

a. The appeal shall be decided on the basis of the record made before the presiding officer in the contested case hearing and no additional evidence shall be presented.

b. The appeal shall include a statement of the specific issues presented for review and the precise ruling or relief requested.

c. An appeal of the presiding officer's decision shall be submitted in writing by sending the original and one copy of the appeal to the director of the motor vehicle division.

d. An appeal shall be deemed timely submitted if it is delivered to the director of the motor vehicle division or properly addressed and postmarked within ten days after receipt of the presiding officer's decision.

e. The director of the motor vehicle division shall forward the appeal to the director of transportation. The director of transportation may affirm, modify or reverse the decision of the presiding officer, or may remand the case to the presiding officer.

f. Failure to timely appeal a decision shall be considered a failure to exhaust administrative remedies.

**620.4(3) Final agency action.** The decision of the director of transportation shall be the final decision of the department and shall constitute final agency action for purposes of judicial review. No further steps are necessary to exhaust administrative remedies.

**620.4(4) Default.**

a. If a party fails to appear or participate in a contested case proceeding after proper service of notice, the presiding officer may, if no continuance is granted, either enter a default decision or proceed with the hearing and render a decision in the absence of the party.

b. Any party may move for default against a party who has requested the contested case proceeding and who has failed to appear after proper service.

c. A default decision or a decision rendered on the merits after a party has failed to appear or participate in a contested case proceeding becomes final agency action unless, within ten days after receipt of the decision, either a motion to vacate is filed and served on the presiding officer and the other parties or an appeal of a decision on the merits is timely submitted in accordance with subrule 620.4(2). A motion to vacate must state all facts relied upon by the moving party which establish that good cause existed for that party's failure to appear or participate.

d. The time for further appeal of a decision for which a timely motion to vacate has been filed is stayed pending a decision on the motion to vacate.

e. Timely filed motions to vacate shall be granted only for good cause shown. The burden of proof is on the moving party. Adverse parties shall have ten days to respond to a motion to vacate.

f. "Good cause" for the purpose of this rule means surprise, excusable neglect or unavoidable casualty.

g. A decision denying a motion to vacate is subject to further appeal in accordance with subrule 620.4(2).

h. A decision granting a motion to vacate is subject to interlocutory appeal by the adverse party in accordance with subrule 620.4(2).

i. If a motion to vacate is granted and no timely interlocutory appeal has been taken, the presiding officer shall issue another notice of hearing and the contested case shall proceed accordingly.

**620.4(5) Petition to reopen a hearing.**

a. A petition to reopen a hearing pursuant to Iowa Code section 17A.16 shall be submitted in writing to the director of the motor vehicle division. If a petition is based on a court order, a copy of the court order shall be submitted with the petition. If a petition is based on new evidence, the petitioner shall submit a concise statement of the new evidence and the reason(s) for the unavailability of the evidence at the original hearing.

b. A petition to reopen a hearing may be submitted at any time even if a hearing to contest the revocation was not originally requested or held.

c. A person may appeal a denial of the petition to reopen. The appeal shall be deemed timely if it is delivered to the director of the motor vehicle division or properly addressed and postmarked within 20 days after issuance of the decision denying the petition to reopen.

[ARC 4001C, IAB 9/12/18, effective 10/17/18; ARC 4760C, IAB 11/6/19, effective 12/11/19; ARC 5941C, IAB 10/6/21, effective 11/10/21]

**761—620.5(321J) Reinstatement.** The department may reinstate the license when the revocation has ended if the person has:

**620.5(1)** Filed proof of financial responsibility under Iowa Code chapter 321A for all motor vehicles to be operated.

**620.5(2)** Paid the \$200 civil penalty.

**620.5(3)** Provided proof of satisfactory completion of a course for drinking drivers and proof of completion of substance abuse evaluation and treatment or rehabilitation services on a form and in a manner approved by the department.

**620.5(4)** Successfully completed the required driver license examination.

**620.5(5)** Paid the specified reinstatement fee.

**620.5(6)** Paid the appropriate license or permit fee.

**620.5(7)** Provided, if required by Iowa Code section 321J.17(3), proof of installation of an approved ignition interlock device or proof the person remains in compliance with the ignition interlock device requirement if the device was installed for a temporary restricted license.

[ARC 4001C, IAB 9/12/18, effective 10/17/18; ARC 5429C, IAB 2/10/21, effective 3/17/21]

**761—620.6(321J) Issuance of temporary restricted license after revocation period has expired.** The department may issue a temporary restricted license to a person whose period of revocation under Iowa Code chapter 321J has expired but who has not met all the requirements for license reinstatement. The period of issuance shall be determined by the department, but it shall not exceed six months from the end of the original revocation period.

**620.6(1)** An applicant for a temporary restricted license under this rule must meet one of the following two conditions:

*a.* The applicant must demonstrate to the satisfaction of the department that a course for drinking drivers was not readily available to the person during the revocation period and that the applicant has enrolled in a course for drinking drivers. The applicant must furnish the dates the class will begin and end.

*b.* The applicant must demonstrate to the satisfaction of the department that substance abuse evaluation and treatment or rehabilitation services have not been completed because of an inability to schedule them or because they are ongoing.

**620.6(2)** An applicant for a temporary restricted license under this rule must meet all other conditions for issuance of a temporary restricted license under rule 761—620.3(321J) and Iowa Code section 321J.20, including installation of an ignition interlock device.

**761—620.7 to 620.9** Reserved.

**761—620.10(321J) Revocation for deferred judgment.** The revocation period under Iowa Code subsection 321J.4(3) shall be 90 days.

**761—620.11 to 620.14** Reserved.

**761—620.15(321J) Substance abuse evaluation and treatment or rehabilitation services.** When the department revokes a person's license under Iowa Code chapter 321J, the department shall also order the person to submit to substance abuse evaluation and, if recommended, treatment or rehabilitation services. A provider of substance abuse evaluation and treatment or rehabilitation programs shall be licensed by the Iowa department of public health, division of substance abuse.

**620.15(1) Reporting.**

*a.* When a person who has been ordered to attend a substance abuse program has satisfactorily completed the program, the program provider shall electronically report completion to the department in a manner approved by the department.

*b.* Reporting to the department shall be in accordance with Iowa Code sections 125.37, 125.84 and 125.86 and the federal confidentiality regulations, "Confidentiality of Alcohol and Drug Abuse Patient Records," 42 CFR Part 2.

**620.15(2) Payment.** Payment of substance abuse evaluation and treatment or rehabilitation costs shall be in accordance with Iowa department of public health rules.

[ARC 4001C, IAB 9/12/18, effective 10/17/18]

**761—620.16(321J) Drinking drivers course.** When the department revokes a person's license under Iowa Code chapter 321J, the department shall order the person to enroll, attend and satisfactorily complete a course for drinking drivers, as provided in Iowa Code section 321J.22.

**620.16(1) Reporting.**

a. When a person who has been ordered to attend a drinking drivers course has successfully completed the course, the program provider under Iowa Code section 321J.22(2) "a" shall electronically report completion to the department in a manner approved by the department.

b. Reserved.

**620.16(2) Payment.** A person ordered to complete a drinking drivers course is responsible for payment of course fees and expenses in accordance with Iowa Code section 321J.22.

[ARC 4001C, IAB 9/12/18, effective 10/17/18]

**761—620.17(321J) Sobriety and drug monitoring program.** Rescinded ARC 5429C, IAB 2/10/21, effective 3/17/21.

These rules are intended to implement Iowa Code chapter 17A; chapter 321J as amended by 2021 Iowa Acts, House File 757, sections 2 to 7; and sections 321.193, 321.201, 321.376 and 707.6A.

[Filed emergency 5/27/82—published 6/23/82, effective 7/1/82]

[Filed 12/1/82, Notice 6/23/82—published 12/22/82, effective 1/26/83]

[Filed emergency 6/20/84—published 7/18/84, effective 7/1/84]

[Filed 11/27/85, Notice 10/9/85—published 12/18/85, effective 1/22/86]

[Filed emergency 6/20/86—published 7/16/86, effective 7/1/86]

[Filed 5/11/87, Notice 3/11/87—published 6/3/87, effective 7/8/87]

[Filed 1/20/88, Notice 12/2/87—published 2/10/88, effective 3/16/88]

[Filed emergency 5/16/88—published 6/15/88, effective 5/16/88]

[Filed 11/3/88, Notice 9/21/88—published 11/30/88, effective 1/4/89]

[Filed 3/23/89, Notice 2/8/89—published 4/19/89, effective 5/24/89]

[Filed emergency 11/30/89—published 12/27/89, effective 12/1/89]

[Filed 12/18/91, Notice 11/13/91—published 1/8/92, effective 2/12/92]

[Filed 11/4/93, Notice 9/29/93—published 11/24/93, effective 12/29/93]

[Filed 11/1/95, Notice 9/27/95—published 11/22/95, effective 12/27/95]

[Filed 12/24/97, Notice 11/19/97—published 1/14/98, effective 2/18/98]

[Filed 1/21/98, Notice 12/17/97—published 2/11/98, effective 3/18/98]

[Filed 10/28/98, Notice 9/23/98—published 11/18/98, effective 12/23/98]

[Filed 2/17/99, Notice 1/13/99—published 3/10/99, effective 4/14/99]

[Filed 4/8/99, Notice 2/10/99—published 5/5/99, effective 7/1/99]

[Filed 6/19/02, Notice 4/17/02—published 7/10/02, effective 8/14/02]

[Filed 10/11/06, Notice 8/30/06—published 11/8/06, effective 12/13/06]

[Filed 12/12/07, Notice 11/7/07—published 1/2/08, effective 2/6/08]

[Filed Emergency ARC 8024B, IAB 8/12/09, effective 7/14/09]

[Filed ARC 8203B (Notice ARC 8025B, IAB 8/12/09), IAB 10/7/09, effective 11/11/09]

[Filed ARC 4001C (Notice ARC 3889C, IAB 7/18/18), IAB 9/12/18, effective 10/17/18]

[Filed ARC 4347C (Notice ARC 4229C, IAB 1/16/19), IAB 3/13/19, effective 4/17/19]

[Filed ARC 4760C (Notice ARC 4623C, IAB 8/28/19), IAB 11/6/19, effective 12/11/19]

[Filed ARC 5429C (Notice ARC 5311C, IAB 12/16/20), IAB 2/10/21, effective 3/17/21]

[Filed ARC 5941C (Notice ARC 5858C, IAB 8/11/21), IAB 10/6/21, effective 11/10/21]

CHAPTERS 621 to 624  
Reserved



CHAPTER 625  
DRIVER'S LICENSES FOR UNDERCOVER  
LAW ENFORCEMENT OFFICERS

**761—625.1(321) Purpose.** This chapter addresses the issuance of undercover driver's licenses.

**761—625.2(321) Application.**

**625.2(1)** The application for an undercover driver's license must:

- a. Be in writing.
- b. Include a fictitious name as well as the applicant's true identity.
- c. Include a statement of need.
- d. Be signed by both the applicant and the head of the law enforcement agency employing the applicant.
- e. Be submitted to the Bureau of Investigation and Identity Protection, Iowa Department of Transportation, 6310 SE Convenience Blvd., Ankeny, Iowa 50021.

**625.2(2)** All applications shall be investigated by the department. An investigation shall include, but not be limited to, a 50-state check of the fictitious name and verification of the applicant's employment with the sponsoring law enforcement agency.

**625.2(3)** The department shall determine if the undercover license is necessary.

**625.2(4)** The department shall approve or deny the application, based on the results of the investigation and the determination of necessity.

**625.2(5)** An applicant employed by a state or local law enforcement agency that is located in a state other than Iowa is not eligible for an undercover driver's license issued under this chapter.

[ARC 4002C, IAB 9/12/18, effective 10/17/18; ARC 6846C, IAB 2/8/23, effective 3/15/23]

**761—625.3(321) Issuance.**

**625.3(1)** To obtain an undercover license after the application is approved, the applicant must appear at the Motor Vehicle Division offices, Iowa Department of Transportation, 6310 SE Convenience Blvd., Ankeny, Iowa, with all applicable documents necessary for the issuance of an undercover license.

**625.3(2)** The license will be issued with an applicable expiration date as provided in Iowa Code section 321.196. The applicant must pay all fees and meet all requirements for the class of license applied for, except that rule 761—601.5(321) is waived in accordance with the provisions in 6 CFR 37.11.

**625.3(3)** An undercover license may not be renewed. The department may issue a subsequent new undercover license to an applicant who submits a new application and continues to meet the requirements of rule 761—625.2(321).

[ARC 0347C, IAB 10/3/12, effective 11/7/12; ARC 4002C, IAB 9/12/18, effective 10/17/18; ARC 5205C, IAB 10/7/20, effective 11/11/20]

**761—625.4(321) Renewal not permitted.** Rescinded ARC 4002C, IAB 9/12/18, effective 10/17/18.

**761—625.5(321) Cancellation.** When the need for an undercover license no longer exists or if the licensee ceases to be employed by the sponsoring law enforcement agency, the licensee shall surrender the undercover license to the bureau of investigation and identity protection for cancellation.

[ARC 6846C, IAB 2/8/23, effective 3/15/23]

**761—625.6(321) Records.**

**625.6(1)** Applications, forms and other records of the department that establish the true identity of an applicant or licensee under this chapter are confidential public records under Iowa Code sections 22.7, 80G.3 and 321.189A. The fictitious license information itself is not confidential, except as provided in Iowa Code section 321.11.

**625.6(2)** The open public records of the department shall contain no information or indicator that would distinguish any undercover license issued under this chapter from any other driver's license issued by the department.

**625.6(3)** An undercover license issued under this chapter will appear on the driver's license record system.

[ARC 4002C, IAB 9/12/18, effective 10/17/18]

These rules are intended to implement Iowa Code sections 22.7, 80G.3, 321.189, 321.189A and 321.196 and 6 CFR Part 37.

[Filed 8/26/97, Notice 7/2/97—published 9/24/97, effective 10/29/97]

[Filed 10/28/98, Notice 9/23/98—published 11/18/98, effective 12/23/98]

[Filed ARC 0347C (Notice ARC 0201C, IAB 7/11/12), IAB 10/3/12, effective 11/7/12]

[Filed ARC 4002C (Notice ARC 3866C, IAB 7/4/18), IAB 9/12/18, effective 10/17/18]

[Filed ARC 5205C (Notice ARC 5100C, IAB 7/29/20), IAB 10/7/20, effective 11/11/20]  
[Filed ARC 6846C (Notice ARC 6703C, IAB 11/30/22), IAB 2/8/23, effective 3/15/23]

CHAPTERS 626 to 629  
Reserved



CHAPTER 630  
NONOPERATOR'S IDENTIFICATION  
[Prior to 6/3/87, see Transportation Department[820]—(07,C)Ch 12]

**761—630.1(321) General information.**

**630.1(1)** The department shall issue a nonoperator's identification card only to an Iowa resident who does not have a driver's license. However, a card may be issued to a person holding a temporary permit under Iowa Code section 321.181.

**630.1(2)** Information concerning the nonoperator's identification card is available at any driver's license service center or at the address in 761—600.2(17A).

[ARC 4437C, IAB 5/8/19, effective 6/12/19]

**761—630.2(321) Application and issuance.**

**630.2(1)** An applicant for a nonoperator's identification card shall complete and sign an application form at a driver's license service center. The signature shall be without qualification and shall contain only the applicant's usual signature without any other titles, characters or symbols.

**630.2(2)** The applicant shall present proof of identity, date of birth, social security number, Iowa residency, current residential address and lawful status as required by rule 761—601.5(321). If applicable, submission of a parent's, guardian's or custodian's consent is also required in accordance with rule 761—601.6(321). The applicant or a current cardholder may provide the department with emergency contact information in accordance with rule 761—601.3(321).

**630.2(3)** The nonoperator's identification card shall be coded for identification only, as explained on the reverse side of the card. The card shall expire eight years from the date of issue. A card issued to a person who is a foreign national with temporary lawful status shall be issued only for the length of time the person is authorized to be present in the United States as verified by the department, not to exceed two years. However, if the person's lawful status as verified by the department has no expiration date, the card shall be issued for a period of no longer than one year.

**630.2(4)** Upon the request of the cardholder, the department shall indicate on the nonoperator's identification card any of the following:

- a. The presence of a medical condition.
- b. That the cardholder is a donor under the uniform anatomical gift law.
- c. That the cardholder has in effect a medical advance directive.
- d. That the cardholder is hard of hearing or deaf.
- e. That the cardholder is a veteran.

(1) To be eligible for a veteran designation, the cardholder must be an honorably discharged veteran of the armed forces of the United States, the national guard or reserve forces. A cardholder who requests a veteran designation shall submit Form 432035, properly completed by the cardholder and a designee of the Iowa department of veterans affairs, or the cardholder shall present certification of release or discharge from active duty, DD form 214, to the department indicating that the cardholder was honorably discharged from active duty. A cardholder who was a member of the national guard or reserve forces and who applies directly to the department must present a DD form 214 which indicates that the cardholder was honorably discharged after serving for at least a minimum aggregate (total) of 90 days of active duty service for purposes other than training. A cardholder who was a member of the national guard or reserve forces and who has a discharge document other than a DD form 214 must have the cardholder's eligibility for a veteran designation determined by a designee of the Iowa department of veterans affairs and shall apply to the department for a veteran designation by submitting Form 432035, properly completed by the cardholder and a designee of the Iowa department of veterans affairs.

(2) The department may consult with and defer to the Iowa department of veterans affairs regarding what constitutes a properly completed DD form 214 and veteran status in general.

(3) If the department denies issuance of a nonoperator's identification card with a veteran designation upon presentation of the DD form 214 to the department, the cardholder may obtain a card with a veteran designation if the cardholder submits Form 432035, properly completed by the cardholder and a designee of the Iowa department of veterans affairs.

(4) If the department issues a veteran designation in error or as the result of fraud on the part of the cardholder, the nonoperator's identification card with a veteran designation shall be canceled, and a duplicate card without the designation may be issued to the cardholder. There shall be no charge to issue a duplicate card if the card was issued in error, unless the error was the result of fraud on the part of the cardholder.

- f. That the cardholder has autism spectrum disorder.

**630.2(5)** The issuance fee is \$8. However, no issuance fee shall be charged for a person whose license has been suspended for incapability pursuant to rule 761—615.14(321), who has been denied further licensing in lieu of a suspension for incapability pursuant to rule 761—615.4(321), or who voluntarily surrenders the person's license in lieu of suspension for incapability pursuant to rule 761—615.14(321).

**630.2(6)** An applicant who is a foreign national with temporary lawful status must provide documentation of lawful status as required by 761—subrule 601.5(4) at each renewal.

**630.2(7)** A person who seeks a nonoperator's identification card that is compliant with the REAL ID Act of 2005, 49 U.S.C. §30301 note, as further defined in 6 CFR Part 37 ("REAL ID nonoperator's identification card"), must meet and comply with all lawful requirements for an Iowa nonoperator's identification card, and must also meet and comply with all application and documentation requirements set forth at 6 CFR Part 37, including but not limited to documentation of identity, date of birth, social security number, address of principal residence, and evidence of lawful status in the United States. Documents and information provided to fulfill REAL ID requirements must be verified as required in 6 CFR 37.13. An applicant for a REAL ID nonoperator's identification card is subject to a mandatory facial image capture that meets the requirements of 6 CFR 37.11(a). A REAL ID nonoperator's identification card may not be issued, reissued, or renewed except as permitted in 6 CFR Part 37 and may not be issued, reissued, or renewed by any procedure, in any circumstance, to any person, or for any term prohibited under 6 CFR Part 37. The information on the front of any REAL ID nonoperator's identification card must include all information and markings required by 6 CFR 37.17. Nothing in this subrule requires a person to obtain a REAL ID nonoperator's identification card.

**630.2(8)** A nonoperator's identification card issued to a foreign national with temporary lawful status shall include the following statement on the face of the card: "limited term."

**630.2(9)** A nonoperator's identification card that is not issued as a REAL ID nonoperator's identification card as defined in subrule 630.2(7) may be marked as required by 6 CFR 37.71 and any subsequent guidance issued by the U.S. Department of Homeland Security.

**630.2(10)** The department may determine means or methods for electronic renewal of a nonoperator's identification card.

*a.* An applicant who meets the following criteria may apply for electronic renewal:

- (1) The applicant must be at least 18 years old.
- (2) The applicant updated the applicant's photo at the applicant's last issuance or renewal.
- (3) The applicant's nonoperator's identification card has not been expired for more than one year.
- (4) The department's records show the applicant is a U.S. citizen.
- (5) The applicant's nonoperator's identification card is not marked "valid without photo."
- (6) The applicant is not seeking to change any of the following as it appears on the applicant's nonoperator's identification card:

1. Name.
2. Date of birth.
3. Sex.

*b.* An applicant who has not previously been issued a REAL ID nonoperator's identification card may not request a REAL ID nonoperator's identification card by electronic renewal.

**630.2(11)** An applicant for a nonoperator's identification card shall surrender all other driver's licenses and nonoperator's identification cards, other than a temporary permit held under Iowa Code section 321.181. This includes any driver's licenses or nonoperator's identification cards issued by a state other than Iowa or a foreign jurisdiction, unless otherwise provided in a letter of understanding or other written memorialization of reciprocity or understanding. An applicant who renews a nonoperator's identification card electronically pursuant to subrule 630.2(10) shall destroy the previous nonoperator's identification card upon receipt of a renewed nonoperator's identification card.

[ARC 8339B, IAB 12/2/09, effective 12/21/09; ARC 8514B, IAB 2/10/10, effective 3/17/10; ARC 9991B, IAB 2/8/12, effective 3/14/12; ARC 0347C, IAB 10/3/12, effective 11/7/12; ARC 0895C, IAB 8/7/13, effective 7/9/13; ARC 1073C, IAB 10/2/13, effective 11/6/13; ARC 1714C, IAB 11/12/14, effective 12/17/14; ARC 2888C, IAB 1/4/17, effective 2/8/17; ARC 3451C, IAB 11/8/17, effective 12/13/17; ARC 4437C, IAB 5/8/19, effective 6/12/19; ARC 5302C, IAB 12/2/20, effective 1/6/21; ARC 6306C, IAB 5/4/22, effective 6/8/22]

### **761—630.3(321) Duplicate card.**

**630.3(1)** *Lost, stolen or destroyed card.* To replace a nonoperator's identification card that is lost, stolen or destroyed, the cardholder shall provide the cardholder's full legal name, date of birth, and social security number, all of which must be verified by the department, and pay the replacement fee. A cardholder subject to 761—paragraph 601.5(2) "b" shall provide the applicant's U.S. Customs and Immigration Services number, which

must be verified by the department. The department may investigate or require additional information as may be reasonably necessary to determine that the cardholder's identity matches the identity of record and shall not issue the replacement card if the cardholder's identity is questionable, cannot be determined, or otherwise does not match the identity of record. If the cardholder's current residential address, name, date of birth, or sex designation has changed since the previous card was issued, the cardholder shall comply with 761—subrule 605.11(2).

**630.3(2) Voluntary replacement.** To voluntarily replace a nonoperator's identification card, the cardholder shall surrender to the department the card to be replaced. The reasons a card may be voluntarily replaced and any additional supporting documentation required are the same as those listed in 761—paragraphs 605.11(2)“a” to “j.”

**630.3(3) Replacement upon attaining the age of 21.** A cardholder, upon attaining the age of 21, who is otherwise eligible for a nonoperator's identification card, is eligible to electronically apply for a replacement card under this rule for the unexpired months of the card, regardless of whether the most recent issuance occurred electronically.

a. Except for the requirements in 761—subparagraphs 605.25(7)“a”(1) and 605.25(7)“a”(2), the cardholder must meet the eligibility requirements listed in 761—paragraph 605.25(7)“a” to replace the card electronically and must also meet the following criteria:

(1) The cardholder must be at least 21 years old.

(2) The cardholder must currently hold a nonoperator's identification card marked “Under 21” as provided in Iowa Code section 321.190.

b. Reserved.

**630.3(4) Fee.** The fee to replace a nonoperator's identification card is the same amount as the fee required to replace a driver's license. See 761—subrule 605.11(4).

[ARC 0347C, IAB 10/3/12, effective 11/7/12; ARC 1714C, IAB 11/12/14, effective 12/17/14; ARC 3451C, IAB 11/8/17, effective 12/13/17; ARC 4851C, IAB 1/1/20, effective 2/5/20]

**761—630.4(321) Cancellation.** The department shall cancel a nonoperator's identification card upon receipt of evidence that the person was not entitled or is no longer entitled to a card, failed to give correct information, committed fraud in applying or used the card unlawfully.

These rules are intended to implement Iowa Code sections 321.13, 321.189, 321.190, 321.195, 321.216, 321.216A, 321.216B and 321.216C, the REAL ID Act of 2005 (49 U.S.C. Section 30301 note), and 6 CFR Part 37.

[Filed 12/28/76, Notice 11/3/76—published 1/12/77, effective 2/16/77]

[Filed emergency 6/20/84—published 7/18/84, effective 7/1/84]

[Filed 5/11/87, Notice 3/11/87—published 6/3/87, effective 7/8/87]

[Filed 1/20/88, Notice 12/2/87—published 2/10/88, effective 3/16/88]

[Filed 9/21/89, Notice 7/26/89—published 10/18/89, effective 11/22/89]

[Filed emergency 6/7/90—published 6/27/90, effective 7/1/90]

[Filed 12/18/91, Notice 11/13/91—published 1/8/92, effective 2/12/92]

[Filed 11/1/95, Notice 9/27/95—published 11/22/95, effective 12/27/95]

[Filed 10/30/96, Notice 9/25/96—published 11/20/96, effective 12/25/96]

[Filed 1/21/98, Notice 12/17/97—published 2/11/98, effective 3/18/98]

[Filed 10/28/98, Notice 9/23/98—published 11/18/98, effective 12/23/98]

[Filed emergency 7/20/00 after Notice 6/14/00—published 8/9/00, effective 7/24/00]

[Filed 6/19/02, Notice 4/17/02—published 7/10/02, effective 8/14/02]

[Filed 10/11/06, Notice 8/30/06—published 11/8/06, effective 12/13/06]

[Filed Emergency ARC 8339B, IAB 12/2/09, effective 12/21/09]

[Filed ARC 8514B (Notice ARC 8342B, IAB 12/2/09), IAB 2/10/10, effective 3/17/10]

[Filed ARC 9991B (Notice ARC 9874B, IAB 11/30/11), IAB 2/8/12, effective 3/14/12]

[Filed ARC 0347C (Notice ARC 0201C, IAB 7/11/12), IAB 10/3/12, effective 11/7/12]

[Filed Emergency ARC 0895C, IAB 8/7/13, effective 7/9/13]

[Filed ARC 1073C (Notice ARC 0894C, IAB 8/7/13), IAB 10/2/13, effective 11/6/13]

[Filed ARC 1714C (Notice ARC 1601C, IAB 9/3/14), IAB 11/12/14, effective 12/17/14]

[Filed ARC 2888C (Notice ARC 2800C, IAB 11/9/16), IAB 1/4/17, effective 2/8/17]

[Filed ARC 3451C (Notice ARC 3307C, IAB 9/13/17), IAB 11/8/17, effective 12/13/17]

[Filed ARC 4437C (Notice ARC 4313C, IAB 2/27/19), IAB 5/8/19, effective 6/12/19]

[Filed ARC 4851C (Notice ARC 4715C, IAB 10/23/19), IAB 1/1/20, effective 2/5/20]

[Filed ARC 5302C (Notice ARC 5179C, IAB 9/23/20), IAB 12/2/20, effective 1/6/21]

[Filed ARC 6306C (Notice ARC 6200C, IAB 2/23/22), IAB 5/4/22, effective 6/8/22]



CHAPTERS 631 to 633  
Reserved



CHAPTER 634  
DRIVER EDUCATION

**761—634.1(321) Information and location.** Applications, forms and information regarding this chapter are available by mail from the Motor Vehicle Division, Iowa Department of Transportation, P.O. Box 9204, Des Moines, Iowa 50306-9204; in person at 6310 SE Convenience Blvd., Ankeny, Iowa; by telephone at (515)244-8725; by facsimile at (515)239-1837; or on the department's website at [www.iowadot.gov](http://www.iowadot.gov).

[ARC 4909C, IAB 2/12/20, effective 3/18/20; ARC 6062C, IAB 12/1/21, effective 1/5/22]

**761—634.2(321) Definitions.**

*"Behind-the-wheel instruction"* means the street or highway driving instruction component of an approved driver education course.

*"Instructor,"* for purposes of this chapter, means a person certified to provide behind-the-wheel instruction.

*"Laboratory instruction"* includes instruction received by a student while the student is in the driver education vehicle or adjacent to it as referred to in paragraphs 634.4(2) *"c"* and 634.4(2) *"d"* and may also include range or simulation as referred to in paragraphs 634.4(2) *"h"* and 634.4(2) *"i."*

*"Serious injury"* means the same as defined in Iowa Code section 702.18.

*"Teacher"* means the same as defined in Iowa Code section 272.1.

[ARC 4909C, IAB 2/12/20, effective 3/18/20]

**761—634.3** Reserved.

**761—634.4(321) Driver education course standards and requirements.**

**634.4(1) Course approval.** Any school district, area education agency, merged area school, other agency or person planning to offer a driver education course must receive course approval, which includes approval of all teachers and instructors listed on the application, from the department prior to the beginning of the first class that is offered and annually thereafter. The agency or institution or person shall apply for course approval in a manner determined by the department. Course approval must be renewed annually. The approval is valid for one calendar year or a remaining calendar year and expires on December 31. The application for course renewal shall be submitted to the department within 60 days of the expiration date, unless otherwise approved by the department.

**634.4(2) Course requirements.** Driver education courses provided by approved programs must comply with the following:

*a.* Schools shall provide for each student a minimum of 1800 minutes in classroom instruction, plus 360 minutes in supervised laboratory instruction, exclusive of observation time, in a dual-control motor vehicle.

*b.* Each student shall be scheduled to receive classroom or laboratory instruction each week of the course. Except upon showing of good cause, laboratory instruction shall not conclude later than 45 days after classroom instruction has been completed. When the driver education course provider determines there is good cause, the laboratory instruction shall not conclude later than 90 days after classroom instruction has been completed. For the purpose of this paragraph, "good cause" means an unanticipated event causing a delay in the student's ability to complete the laboratory instruction if the event is beyond the student's control.

*c.* Behind-the-wheel instruction shall be limited to a maximum of 30 minutes per student per session and a maximum of 60 minutes in a single day.

*d.* Two or more students shall be scheduled for all behind-the-wheel instruction to ensure that appropriate observation time is experienced.

*e.* Routine maintenance of motor vehicles to maximize energy efficiency and safety shall be included in classroom instruction.

*f.* Operation of motor vehicles to maximize energy efficiency and safety shall be included in classroom instruction.

*g.* Each school district shall provide students who are absent from instruction an opportunity to make up a reasonable amount of time and coursework.

*h.* When driving simulators are used for part of the behind-the-wheel driving experience, four hours of simulator experience shall be considered equal to one hour of behind-the-wheel driving in the car. However, in addition to simulator time, a minimum of three hours of on-street, behind-the-wheel driving must be completed.

*i.* When driving ranges are used in driver education courses, two hours of range experience shall be considered equal to one hour of on-street, behind-the-wheel driving. However, in addition to range time, a minimum of three hours of on-street, behind-the-wheel driving must be completed.

*j.* Motor vehicles which are designed primarily for carrying nine or fewer occupants, excluding motorcycles and mopeds, are the only motor vehicles approved for use in driver education courses, and each shall be equipped with a dual control. In addition, all driver education vehicles shall have an inside rearview mirror and an outside rearview mirror mounted on each side of the vehicle.

*k.* The driver education teacher or instructor shall verify at the beginning of each course that each student possesses a valid instruction permit or driver's license. Each student shall be responsible for possessing an instruction permit or driver's license throughout all laboratory instruction and report any suspension, revocation or cancellation of the instruction permit or driver's license to the driver education teacher or instructor prior to attending laboratory instruction.

**634.4(3)** *Experimental program.* Approval of an experimental program may be granted by the department if based on student or school district need for improved instruction. The maximum duration of an experimental program shall be three years. Annual documentation of the effectiveness of instruction is required and must be submitted to the department subsequent to program completion.

[ARC 4909C, IAB 2/12/20, effective 3/18/20; ARC 6337C, IAB 6/1/22, effective 7/6/22]

**761—634.5** Reserved.

**761—634.6(321) Instructor qualifications, application and certification.**

**634.6(1)** *Behind-the-wheel instructor qualifications.* To qualify to provide behind-the-wheel instruction, the person must:

*a.* Hold a valid driver's license that permits unaccompanied driving, other than a motorized bicycle license or a temporary restricted license.

*b.* Have a clear driving record for the previous two years. A clear driving record means the person has:

(1) Not been identified as a candidate for driver's license suspension under the habitual violator provisions of rule 761—615.13(321) or the serious violation provisions of rule 761—615.17(321).

(2) No driver's license suspensions, revocations, denials, cancellations, disqualifications or bars.

(3) Not committed an offense that would result in driver's license suspension, revocation, denial, cancellation, disqualification or bar.

(4) No record of a contributive motor vehicle accident that caused the death or serious injury of another person.

(5) No record of two or more contributive motor vehicle accidents in a two-year period.

*c.* Meet the requirements for either a licensed teacher in 282—subrule 13.28(4) or a certified behind-the-wheel instructor in this chapter.

**634.6(2)** *Behind-the-wheel instructor's certification requirements.* Except as otherwise provided in this chapter, the following requirements shall apply to a behind-the-wheel instructor:

*a.* An applicant for an initial behind-the-wheel instructor's certification or a renewal shall apply to the department in a manner determined by the department.

(1) If the application is for an initial behind-the-wheel instructor's certification, instructor approval is valid for a calendar year or the remainder of a calendar year. The instructor approval expires on December 31 but remains valid for an additional 30 days after the expiration date.

(2) If the application is to renew a behind-the-wheel instructor's certification, a person shall do all of the following:

1. Apply to the department annually. Instructor approval is valid for a calendar year or the remainder of a calendar year. The instructor approval expires on December 31 but remains valid for an additional 30 days after the expiration date. An application for renewal of instructor approval shall be submitted within 60 days of the expiration date, unless otherwise approved by the department.

2. Provide behind-the-wheel instruction for a minimum of 12 clock hours during each calendar year.

*b.* Beginning January 1, 2021, a person shall complete at least one state-sponsored or state-approved behind-the-wheel instructor refresher course biennially. The state-sponsored or state-approved course may include electronic completion or remote attendance options, as approved by the department. The department may develop a special course for licensed teachers or peace officers who qualify to provide behind-the-wheel instruction under subrule 634.6(3) or 634.6(5), which shall be reserved only for licensed teachers or peace officers who qualify as behind-the-wheel instructors.

*c.* Upon certification, but prior to providing behind-the-wheel instruction, the person shall be:

(1) Authorized by the Iowa board of educational examiners to provide behind-the-wheel driving instruction.

(2) Employed by a public or licensed commercial or private provider of the approved driver education course.

**634.6(3)** *Instructor's certification for licensed teachers.* A teacher licensed by the Iowa board of educational examiners as provided in 282—subrule 13.28(4) shall be included as an approved instructor on an annual driver education course approval as referenced in subrules 634.4(1) and 634.8(1), and except for the requirements in paragraphs 634.6(2)“a” and 634.6(2)“c,” a teacher shall meet the requirements in subrule 634.6(2) to be certified by the department to provide behind-the-wheel instruction.

**634.6(4)** *Instructor application and certification for a teacher with an expired teacher's license.* A teacher who holds an expired initial, standard, exchange, or master educator license with an endorsement for driver education as provided in 282—subrule 13.28(4) shall meet the requirements in subrule 634.6(2) to be certified by the department to provide behind-the-wheel instruction.

**634.6(5)** *Instructor application and certification for active peace officers and retired peace officers.*

a. A person who is an active peace officer or a retired peace officer as referenced in Iowa Code section 321.178 shall do all of the following to be certified by the department to provide behind-the-wheel instruction:

- (1) Be at least 25 years of age.
- (2) Submit Form 431233 certifying the person's status as an active or retired peace officer.
- (3) Meet all other requirements of subrule 634.6(2), except peace officers or retired peace officers who otherwise qualify under this subrule are not required to meet the requirement of subparagraph 634.6(2)“c”(1).

b. A retired peace officer is only required to submit Form 431233, required under paragraph 634.6(5)“a,” to the department once unless the form is invalid or not accepted by the department.

**634.6(6)** *Instructor application and certification for persons other than licensed teachers, peace officers or retired peace officers.*

a. A person who is not licensed by the Iowa board of educational examiners to provide classroom driver education as provided in 282—subrule 13.28(4), who does not hold an expired teacher's license as referenced in subrule 634.6(4), or who is not a peace officer or a retired peace officer as referenced in Iowa Code section 321.178, shall do all of the following to be certified by the department to provide behind-the-wheel instruction:

- (1) Be at least 25 years of age.
- (2) Meet the requirements in subrule 634.6(2), except that a person certified under this subrule shall complete the instructor refresher course referenced in paragraph 634.6(2)“b” annually until January 1, 2021, and thereafter shall complete the course biennially.
- (3) Have successfully completed the instructor preparation requirements of this subrule, as evidenced by written attestations on a form provided by the department from both the classroom instructor and behind-the-wheel observer. The person seeking a behind-the-wheel certification must apply to the department within 12 months of completion of the instructor preparation course. The department-approved instructor preparation course shall:

1. Consist of 24 clock hours of classroom instruction and 12 clock hours of observed behind-the-wheel instruction.

2. Include, at a minimum, classroom instruction on topics including the psychology of the young driver, behind-the-wheel teaching techniques, and driving route selection. Classroom instruction shall be delivered by staff from a driver education teacher preparation program that is approved by the Iowa board of educational examiners. The duration of a classroom instruction section shall not exceed four hours. Video-conferencing may be used for course delivery.

3. Include observation of behind-the-wheel instruction provided by a person licensed to teach driver education who is specially trained by a driver education teacher preparation program that is approved by the Iowa board of educational examiners and that is designed to observe, coach, and evaluate behind-the-wheel instructor candidates. The duration of a behind-the-wheel session shall not exceed four hours. A dual-controlled motor vehicle must be used.

b. Reserved.

**634.6(7)** *Behind-the-wheel certification—reissuance.*

a. A person whose behind-the-wheel certification has expired and is past the renewal period may be reissued a behind-the-wheel certification without having to retake the behind-the-wheel instructor preparation course only if the person meets all of the following criteria:

- (1) The person held a valid behind-the-wheel certification within the two years immediately preceding the application.

- (2) The person provided a minimum of 12 clock hours of behind-the-wheel instruction within the two years immediately preceding the application.

- (3) The person completed at least one state-sponsored or state-approved behind-the-wheel instructor refresher course within the two calendar years immediately preceding the application unless otherwise exempt under this chapter.

(4) The person completed a minimum of 12 clock hours shadowing a teacher licensed by the Iowa board of educational examiners as provided in 282—subrule 13.28(4) through a department-approved driver education program within 90 days immediately preceding the application.

b. Upon certification, but prior to providing behind-the-wheel instruction, the person shall do all of the following:

(1) Be authorized by the Iowa board of educational examiners to provide behind-the-wheel driving instruction unless otherwise exempt under this chapter.

(2) Be employed by a public or licensed commercial or private provider of the approved driver education course and work under the supervision of a person licensed by the Iowa board of educational examiners as provided in 282—subrule 13.28(4).

[ARC 4909C, IAB 2/12/20, effective 3/18/20]

**761—634.7(321) Instructor disqualification, investigation and cancellation.**

**634.7(1) Disqualifications.** A person shall be disqualified by the department from certification as a behind-the-wheel driving instructor for any of the reasons for which the executive director of the Iowa board of educational examiners would deny an application for licensure, certification or authorization as provided in rule 282—11.35(272).

**634.7(2) Investigation.** The department may investigate an applicant for a behind-the-wheel instructor's certification or an instructor to determine if the applicant or instructor meets the requirements for certification. The investigation may include but is not limited to an inquiry into the applicant's or instructor's criminal history from the department of public safety.

**634.7(3) Cancellation.** The department shall cancel the behind-the-wheel instructor's certification of an individual who no longer qualifies under this chapter.

[ARC 4909C, IAB 2/12/20, effective 3/18/20]

**761—634.8(321) Private and commercial driver education schools.** The department licenses private and commercial driver education schools as follows:

**634.8(1) Course approval.** Before becoming licensed, a driver education school must receive course approval, which includes approval of all teachers and instructors listed on the application, from the department prior to the beginning of the first class that is offered and annually thereafter. Behind-the-wheel instruction must be provided by a person who meets the instructor requirements in rule 761—634.6(321). Evidence of the approvals and certifications must be submitted to the department upon application for a license, upon renewal of a license, and upon reinstatement of a license following cancellation.

**634.8(2) Application and fees.** Application for license issuance or renewal shall be made to the department in a manner determined by the department. The fee for a license or the renewal of a license is \$25. The fee must be paid by cash, money order or check, unless the department approves payment of the fee by electronic means. A money order or check must be for the exact amount and should be made payable to the Treasurer, State of Iowa, or the Department of Transportation.

**634.8(3) Issuance and renewal.** A license to teach driver education shall be issued for a calendar year or remainder of a calendar year. The license expires on December 31 but remains valid for an additional 30 days after the expiration date. The application for renewal shall be submitted to the department within 60 days of the expiration date, unless otherwise approved by the department.

**634.8(4) Cancellation.** A license to teach driver education shall be canceled if the course, teacher, or instructor is no longer approved or the person providing only behind-the-wheel instruction for driver education is no longer certified by the department and authorized by the Iowa board of educational examiners.

[ARC 4909C, IAB 2/12/20, effective 3/18/20]

**761—634.9 and 634.10** Reserved.

**761—634.11(321) Driver education—teaching parent.** As an alternative to a driver education course offered by a course provider approved under rule 761—634.4(321), a teaching parent may instruct a student in an approved course of driver education.

**634.11(1) Definitions.** As used in this rule:

“*Approved course*” means a driver education curriculum approved by the department that meets the requirements of Iowa Code section 321.178A and is appropriate for teaching-parent-directed driver education and related behind-the-wheel instruction.

“*Clear driving record*” means the person currently and during the prior two-year period has not been identified as a candidate for suspension or revocation of a driver's license under the habitual offender or habitual violator

provisions of rule 761—615.9(321) or rule 761—615.13(321); is not subject to a driver's license suspension, revocation, denial, cancellation, disqualification, or bar; and has no record of a conviction for a moving traffic violation determined to be the cause of a motor vehicle accident.

*“Course vendor”* means a third-party vendor that makes available commercially an approved course.

*“Student”* means a person between the ages of 14 and 21 years who is within the custody and control of the teaching parent and who holds a valid Iowa noncommercial instruction permit.

*“Teaching parent”* means the same as defined in Iowa Code section 321.178A.

**634.11(2)** Reserved.

**634.11(3)** *Instruction by a teaching parent.*

a. A teaching parent shall instruct the student using an approved course.

b. The teaching parent shall select the course to be used from the list of approved courses posted on the department's website and shall purchase the course directly from the applicable course vendor.

c. No person shall provide driver education as a teaching parent unless the person meets the definition of a teaching parent, and the department shall not recognize driver education that was:

(1) Provided by a person who does not meet the definition of a teaching parent.

(2) Provided to a person who is not a student as defined in subrule 634.11(1).

(3) Offered under a course other than an approved course.

**634.11(4)** *Course completion—certificate of completion.*

a. Upon the student's completion of an approved course, the teaching parent shall apply for a certificate of completion on behalf of the student. The teaching parent shall provide evidence showing the student's completion of an approved course and substantial compliance with the requirements of Iowa Code section 321.178A, by affidavit signed by the teaching parent on a form provided by the department. The teaching parent shall include with the application all documentation, statements, certifications, and logs required by Iowa Code section 321.178A. The application and all required documentation, statements, certifications, and logs shall be submitted to the motor vehicle division.

b. The department shall review the application and evidence submitted and shall deny certification of completion if:

(1) The course was not conducted by a person meeting the definition of a teaching parent for the student for whom certification is sought.

(2) The application does not properly identify a student eligible to be instructed in driver education by the teaching parent.

(3) The application and evidence do not demonstrate the student's successful completion of an approved course.

(4) The application and evidence do not include all documentation, statements, certifications, and logs required by Iowa Code section 321.178A in adequate and proper form and content.

(5) The department has determined that the application should be rejected for any reason listed in Iowa Code section 321.13.

c. If the application is denied, the department shall issue a letter of denial to the teaching parent explaining the reason or reasons for the denial.

d. If the application is approved, the department shall issue a certificate of completion to the student identified in the application. A certification of completion issued by the department under this subrule shall constitute proof of successful completion of an Iowa-approved course in driver education but shall not be grounds for waiver of a driving test under 761—subrule 604.31(2).

**634.11(5)** *Course approval.*

a. For a course to become an approved course under Iowa Code section 321.178A, a vendor of a driver education curriculum shall submit an application on a form provided by the department to the motor vehicle division, along with a copy of all proposed curriculum materials. A vendor offering an electronic curriculum may provide a uniform resource locator (URL) for the proposed electronic materials.

b. To be designated as an approved course, the curriculum submitted must, at a minimum, meet the requirements of Iowa Code section 321.178A, be appropriate for teaching-parent-directed driver education and related street or highway instruction, and meet or exceed the required content set forth in the Appendix to this rule.

c. The department shall review the application and proposed curriculum and shall issue a letter of denial to the course vendor explaining the reason or reasons for denial if the proposed curriculum does not meet the requirements for an approved course.

d. If the proposed curriculum is approved, the department shall issue a certificate of approval to the vendor designating the curriculum as an approved course and shall list the approved course on the department's website. Course approval will be issued for one calendar year or for the remainder of a calendar year. The approval expires on

December 31 and must be renewed annually by the submission of an application on a form provided by the department and all required materials as set forth in this subrule at least 60 days prior to the expiration date, unless otherwise approved by the department.

[ARC 1612C, IAB 9/3/14, effective 10/8/14; ARC 4909C, IAB 2/12/20, effective 3/18/20; ARC 6062C, IAB 12/1/21, effective 1/5/22; ARC 6337C, IAB 6/1/22, effective 7/6/22]

These rules are intended to implement Iowa Code sections 321.178, 321.178A, 321.180B and 321.194.

[Filed 3/10/04, Notice 2/4/04—published 3/31/04, effective 5/5/04]

[Filed 10/11/06, Notice 8/30/06—published 11/8/06, effective 12/13/06]

[Filed 12/12/07, Notice 11/7/07—published 1/2/08, effective 2/6/08]

[Filed ARC 1612C (Notice ARC 1526C, IAB 7/9/14), IAB 9/3/14, effective 10/8/14]

[Filed ARC 4909C (Notice ARC 4771C, IAB 11/20/19), IAB 2/12/20, effective 3/18/20]

[Filed ARC 6062C (Notice ARC 5922C, IAB 9/22/21), IAB 12/1/21, effective 1/5/22]

[Filed ARC 6337C (Notice ARC 6278C, IAB 4/6/22), IAB 6/1/22, effective 7/6/22]

## Appendix to Rule 761—634.11(321)

To be designated as an approved course, a curriculum must, at a minimum, meet the requirements of Iowa Code section 321.178A, be appropriate for teaching-parent-directed driver education and related street or highway instruction, and meet or exceed the required content listed below:

1. *Duration and required content.* The course must provide for both classroom and behind-the-wheel instruction. As used in this rule, “*classroom instruction*” means instruction provided by a teaching parent in a private setting using printed or electronic course materials, and “*behind-the-wheel instruction*” means street or highway driving instruction provided by a teaching parent or a person who is qualified to provide street or highway driving instruction pursuant to Iowa Code section 321.178 in a motor vehicle operated by the student.
  - a. Classroom instruction shall include all of the following:
    - i. Instruction concerning distracted driving and substance abuse.
    - ii. Instruction concerning railroad crossing safety.
    - iii. Instruction relating to becoming an organ donor under the revised uniform anatomical gift Act as provided in Iowa Code chapter 142C.
    - iv. Instruction providing awareness about sharing the road with pedestrians, bicycles and motorcycles.
  - b. Behind-the-wheel instruction shall consist of at least 40 hours of street or highway driving including 4 hours of driving after sunset and before sunrise while accompanied by the teaching parent or a person who is qualified to provide street or highway driving instruction pursuant to Iowa Code section 321.178.
2. *Required topics.* The course may follow any format the vendor determines, provided all of the following topics are properly and adequately covered, as detailed in the course application form provided by the department:
  - a. Traffic law – *classroom instruction*
    - i. Introduction to driver education and driving laws and privileges.
    - ii. Understanding your license to drive.
    - iii. Right-of-way.
    - iv. Traffic control devices.
    - v. Controlling traffic flow.
    - vi. Alcohol and other drugs.

- vii. Cooperating with other roadway users.
- b. Driver preparation – *classroom and behind-the-wheel instruction*
  - i. Pre-drive tasks.
  - ii. Occupant protection.
  - iii. Symbols and devices.
  - iv. Starting tasks.
  - v. Vehicle operation and control tasks.
  - vi. Post-drive tasks.
  - vii. In-car progress assessment.
  - viii. Driving plan (*classroom instruction*).
- c. Vehicle movements – *classroom and behind-the-wheel instruction*
  - i. Visual attention, mental attention and communication.
  - ii. Reference points.
  - iii. Vehicle balance.
  - iv. Vehicle maneuvers.
  - v. In-car progress assessment (*behind-the-wheel instruction*).
- d. Driver readiness – *classroom and behind-the-wheel instruction*
  - i. Driving practices.
  - ii. Fatigue.
  - iii. Aggressive driving.
  - iv. In-car progress assessment (*behind-the-wheel instruction*).
- e. Risk reduction – *classroom and behind-the-wheel instruction*
  - i. Risk factors.
  - ii. Space management.
  - iii. In-car progress assessment (*behind-the-wheel instruction*).
- f. Environmental factors – *classroom and behind-the-wheel instruction*
  - i. Environmental characteristics.
  - ii. Environmental risk factors.

- iii. In-car progress assessment (*behind-the-wheel instruction*).
- g. Distractions – *classroom and behind-the-wheel instruction*
  - i. Distractions.
  - ii. Multi-task performances.
  - iii. In-car progress assessment (*behind-the-wheel instruction*).
- h. Alcohol and other drugs – *classroom instruction*
  - i. Introduction of alcohol and other drug problems.
  - ii. Nature of alcohol-related crash problems.
  - iii. Physiological effects of alcohol.
  - iv. Psychological effects of alcohol.
  - v. Other drug effects on the driving task.
  - vi. Zero-tolerance in the driving environment.
- i. Vehicle movement and reference points – *behind-the-wheel instruction*
  - i. Vehicle movements and reference points (entering and exiting traffic and parking).
  - ii. In-car progress assessment (*behind-the-wheel instruction*).
- j. Adverse conditions – *classroom instruction*
  - i. Adverse weather and reduced visibility conditions.
  - ii. Traction loss.
  - iii. Emergencies.
- k. Vehicle requirements – *classroom and behind-the-wheel instruction*
  - i. Vehicle malfunctions (*classroom instruction*).
  - ii. Vehicle maintenance (*classroom instruction*).
  - iii. Trip planning (*classroom instruction*).
  - iv. Adverse conditions and vehicle requirements – off-street simulated



CHAPTER 635  
MOTORCYCLE RIDER EDUCATION (MRE)

**761—635.1(321) Definitions.**

*“Approved course”* means the motorcycle rider education course approved by the department.

*“MRE”* means motorcycle rider education.

*“Sponsor”* means an entity that delivers the approved course.

**761—635.2(321) Approved course in motorcycle rider education.**

**635.2(1)** Any entity providing motorcycle rider education to persons under the age of 18 for purposes of early licensing or seeking reimbursement under Iowa Code section 321.179 for providing motorcycle rider education to persons aged 18 and older must teach the motorcycle rider education course approved by the department.

**635.2(2)** A sponsor must receive approval from the department prior to the beginning of the first class offered and annually thereafter. Private or commercial sponsors must also be licensed by the department prior to the beginning of the first class that is offered and annually thereafter. Application for license issuance or renewal shall be made to the department in a manner determined by the department. The fee for a license or the renewal of a license is \$25 for a private or a commercial sponsor. The fee must be paid by cash, money order or check unless the department approves payment of the fee by electronic means. A money order or check must be for the exact amount and should be made payable to the Treasurer, State of Iowa, or the Department of Transportation.

**635.2(3)** A license to provide motorcycle rider education shall be issued for a calendar year or remainder of a calendar year. The license expires on December 31 but remains valid for an additional 30 days after the expiration date. The application for renewal shall be submitted to the department within 60 days of the expiration date, unless otherwise approved by the department.

**635.2(4)** The approved course uses a nationally recognized, research-based curriculum. Only persons successfully completing all elements of the approved course shall be issued an Iowa certificate of completion for motorcycle rider education. The certificate of completion shall be submitted to the department by the methods provided in 761—subrule 602.2(1). Issuance of an Iowa certificate of completion to persons who do not successfully complete the approved course is cause for revocation of the instructor’s license and denial of reimbursement to the sponsor for each student involved.

**635.2(5)** Prior to the beginning of on-cycle instruction, a student enrolled in the approved course must be at least 14 years of age, possess a valid driver’s license as defined in Iowa Code section 321.1, be able to touch the ground with the balls of both feet while sitting astride the training motorcycle, and complete the motorcycle safety course waiver form, including the signature of a parent or legal guardian if the student is under the age of 18.

**635.2(6)** The scheduled time for instruction—classroom, on-cycle, or a combination of both—shall not exceed eight hours in any one calendar day. During on-cycle instruction, a student shall wear a U.S. DOT-approved helmet, an eye-protective device, and protective clothing, including gloves, a long-sleeved shirt or jacket, long pants, and shoes or boots that cover the feet and ankles.

**635.2(7)** The student-instructor ratio for classroom instruction shall not exceed 36 to 1. No more than 12 students may receive on-cycle instruction at one time on a single full-size range. The student-instructor ratio for on-cycle instruction shall not exceed 6 to 1.

**635.2(8)** A driving range used for on-cycle instruction must be paved, free of hazards to motorcycle travel, and have an unobstructed, paved runoff of at least 20 feet in all directions.

**635.2(9)** The sponsor shall provide for each student engaged in on-cycle instruction one fully operational motorcycle manufactured for highway use.

*a.* Each motorcycle must meet two of the following three criteria:

- (1) Have an engine displacement of 500 cubic centimeters or less, or an electric motor of 30 kW or less.
- (2) Have a curb (wet) weight of 440 pounds or less.
- (3) Have a seat height of 30 inches or less.

*b.* A motorcycle that has been modified or contains aftermarket equipment for the purposes of meeting the criteria under paragraph 635.2(9)“*a*” shall not be used for instruction under this subrule.

**635.2(10)** The driving test for a Class M driver’s license or a motorcycle endorsement may be waived under 761—subrule 604.31(2) provided the applicant has successfully completed the approved course.

[ARC 3452C, IAB 11/8/17, effective 12/13/17; ARC 5204C, IAB 10/7/20, effective 11/11/20]

**761—635.3(321) Instructors.**

**635.3(1) License.** An instructor of the approved course must be licensed by the department. However, an individual who meets the qualifications for a license except for paragraph 635.3(2)“d” or whose license is denied under paragraph 635.3(3)“c” may teach the approved course as provided in those paragraphs.

**635.3(2) Licensing provisions.** A motorcycle rider education instructor’s license shall be issued for a calendar year or remainder of a calendar year. The license expires on December 31 but remains valid for an additional 30 days after the expiration date of the year it is issued. The application for renewal shall be submitted to the department within 60 days of the expiration date, unless otherwise approved by the department. To obtain and retain an MRE instructor’s license, an individual must:

a. Possess a valid Class M driver’s license or a motorcycle endorsement or equivalent license or endorsement that is valid for a two-wheel motorcycle.

b. Successfully complete a nationally recognized, research-based instructor preparation course approved by the department.

c. Possess a current instructor certification from a nationally recognized motorcycle safety organization approved by the department.

d. Before a license is granted, teach one class of the approved course under the guidance of an experienced, licensed instructor approved by the department.

e. After the year in which a license is granted, teach at least one nationally recognized, research-based motorcycle rider preparation course approved by the department in Iowa or another state each calendar year.

f. After the year in which a license is granted, complete at least one state-sponsored or state-approved instructor update each calendar year. The update must be completed in Iowa every other year.

g. Have a clear driving record for the previous two years. A clear driving record means the individual has:

(1) Not been identified as a candidate for driver’s license suspension under the habitual violator provisions of rule 761—615.13(321) or the serious violation provisions of rule 761—615.17(321).

(2) No driver’s license suspensions, revocations, denials, cancellations, disqualifications or bars.

(3) Not committed an offense that would result in driver’s license suspension, revocation, denial, cancellation, disqualification or bar.

(4) No record of a law enforcement investigative report indicating a contributive motor vehicle accident that caused the death or serious injury of another person.

(5) No record of two or more contributive motor vehicle accidents in a two-year period.

**635.3(3) License cancellations and denials.**

a. The department shall cancel or deny the MRE license of an MRE instructor who does not have a clear driving record under paragraph 635.3(2)“g.” The cancellation or denial shall remain in effect until the individual has a clear driving record, as defined in paragraph 635.3(2)“g.”

b. The department shall cancel or deny the MRE license of an MRE instructor who fails to maintain a current instructor certification from a nationally recognized motorcycle safety organization approved by the department. The cancellation or denial shall remain in effect until the certification is current.

c. Each January, the department shall review each MRE instructor’s teaching activity and update completion. The department shall deny renewal of the MRE license of an MRE instructor who fails to meet these licensing provisions. The denial shall remain in effect until the individual has done the following:

(1) Obtained instructor certification from a nationally recognized motorcycle safety organization approved by the department.

(2) Taught one class of the approved course under the guidance of an experienced, licensed instructor approved by the department.

[ARC 5204C, IAB 10/7/20, effective 11/11/20]

**761—635.4(321) Responsibilities of sponsors.**

**635.4(1) Sponsors shall:**

a. Comply with all teaching and instructor provisions of the approved course.

b. Use only instructors licensed by the department to teach the approved course. However, an individual who meets the qualifications for a license except for paragraph 635.3(2)“d” or whose license is denied under paragraph 635.3(3)“c” may teach the approved course as provided in those paragraphs.

c. Maintain liability insurance in an amount of not less than \$1 million, combined single limit, with an aggregate limit of not less than \$2 million, and file a certificate of this insurance with the department. The certificate shall verify coverage for scheduled courses of instruction. The certificate shall name the department and its officers, agents, representatives and employees as additional insureds with respect to all work, deliveries or services performed for

them by the named insured, and shall specify that the department of transportation, motor vehicle division, shall be given at least 30 days' prior notice of any material change in or cancellation of the insurance.

A sponsor who is a state agency or public educational institution shall provide written verification of self-insurance to the department.

*d.* Maintain complete instructional accident report files and furnish this information to the department in a manner determined by the department.

*e.* Maintain a record of costs incurred in providing the approved course.

*f.* Allow the department or the department's designee to audit any class of the approved course, either announced or unannounced.

*g.* Involve a program administrator in an annual department-sponsored, in-service seminar.

*h.* Provide and maintain adequate instructional facilities and equipment to accommodate all components—lecture, audio-visual, and on-cycle—of the approved course.

**635.4(2)** The department shall deny approval to a sponsor applying for initial or annual approval from the department under subrule 635.2(2) if the sponsor fails to comply with all of the provisions of subrule 635.4(1).

[ARC 5204C, IAB 10/7/20, effective 11/11/20; Editorial change: IAC Supplement 12/28/22]

**761—635.5(321) Use of motorcycle rider education fund.** The motorcycle rider education fund may be used for the following purposes:

**635.5(1) Course development.** New or current sponsors may apply to the department for funds to establish delivery of the approved course at an unserved site. Current sponsors may apply for funds to expand delivery at an existing site.

*a.* Expenditures eligible for funding are limited to:

(1) Acquisition of necessary classroom furnishings and audio-visual systems if used exclusively to deliver the approved course.

(2) Required curriculum materials including necessary audio and visual components.

(3) Range development and maintenance excluding land acquisition, surfacing and resurfacing.

(4) Training motorcycles and motorcycle maintenance equipment if the equipment is to be used exclusively for the upkeep of the motorcycles.

(5) On-cycle safety equipment limited to helmets, eye-protective devices and gloves.

*b.* Application for funds shall be made in a manner determined by the department. Departmental approval shall be based on the geographical area, the number of students to be served and the availability of moneys in the motorcycle rider education fund. The number of students to be served is determined by range size, the number of courses to be offered, and the number of sponsors providing the course.

*c.* Payment to the sponsor for course development expenditures shall be on a cost-reimbursement basis and shall be made after claims under subrule 635.5(5) are paid.

**635.5(2) Instructor preparation.** The department shall sponsor initial instructor preparation courses.

*a.* An instructor preparation course is open to any individual who:

(1) Possesses a valid Class M driver's license or a motorcycle endorsement or equivalent license or endorsement that is valid for a two-wheel motorcycle.

(2) Submits verification from an approved sponsor of employment as an instructor of the approved course to be offered within the next 12 months.

*b.* Upon proof of successful completion of the instructor preparation course, an individual may be reimbursed for course tuition.

*c.* Applications for enrollment shall be made in a manner determined by the department.

**635.5(3) Instructor updates.** The department shall sponsor and fund instructor updates held in Iowa. Instructor updates shall be open to all state-licensed MRE instructors and instructor trainers.

**635.5(4) Instructor trainer preparation.**

*a.* An experienced, state-licensed MRE instructor may apply to the department for funding assistance on forms provided by the department if both the following occur:

(1) The instructor is accepted for enrollment in a nationally recognized instructor trainer preparation course approved by the department.

(2) The instructor agrees to be an instructor trainer in a department-sponsored instructor preparation course within 12 months following successful completion of the instructor trainer preparation course.

*b.* The department may approve the application if the department determines there is a need for additional instructor trainers.

*c.* If the department approves the application, then all the following shall apply:

- (1) Funding assistance shall be limited to course tuition, travel, and subsistence (meals and lodging).
- (2) Upon approval of the application, the department shall pay for course tuition and travel to the training site.
- (3) Upon receipt by the department of evidence of successful completion accompanied by documentation of subsistence expenses incurred, the department shall reimburse the instructor for food and lodging based on the in-state reimbursement limits established for state employees by the department of administrative services.
- (4) If the instructor fails to attend the training, the instructor must repay the department both the course tuition and the travel purchased.
- (5) If the instructor fails to successfully complete the course, the instructor must repay the department one-half the course tuition and one-half the travel purchased. Meal and lodging expenses shall not be reimbursed.

**635.5(5) Reimbursement of per pupil costs.** The department shall reimburse a sponsor for each student who completes the approved course contingent upon the availability of moneys in the motorcycle rider education fund.

*a.* Reimbursement shall be paid twice each calendar year, once for training provided from January to June and once for training provided from July to December.

*b.* The reimbursement will be based on a per pupil rate determined semiannually by the department. The rate will be based on the amount of moneys available in the motorcycle rider education fund, less the administrative and instructor training costs, and will be distributed to sponsors based on the total number of students who complete the approved course.

*c.* Claims for reimbursement shall include a summary of courses taught with site, date, and instructor information, and a report for each class taught that provides the name, age, and driver's license number of each student, and any other information required by the department. Claims for reimbursement shall be submitted in a manner determined by the department.

*d.* Failure to provide course, instructor and student information, failure to meet instructor certification and licensure requirements, or failure to meet prescribed instructor-student ratios shall result in the forfeiture of reimbursement for those courses and students involved.

[ARC 5204C, IAB 10/7/20, effective 11/11/20]

**761—635.6(321) Information and location.** Applications, forms and information regarding this chapter are available by mail from the Motor Vehicle Division, Iowa Department of Transportation, P.O. Box 9204, Des Moines, Iowa 50306-9204; in person at 6310 SE Convenience Blvd., Ankeny, Iowa; by telephone at (515)244-8725; by facsimile at (515)239-1837; or by email at [mre.dot@iowadot.us](mailto:mre.dot@iowadot.us).

[ARC 5204C, IAB 10/7/20, effective 11/11/20; Editorial change: IAC Supplement 12/28/22]

**761—635.7(321) License issuance.** To be licensed to provide MRE, the sponsor's course and instructors must be approved by the department in accordance with this chapter.

**635.7(1) Issuance and renewal.** A license to provide MRE shall be issued for a calendar year or remainder of a calendar year. The license expires on December 31 and must be renewed annually.

**635.7(2) Cancellation.** A license to provide MRE shall be canceled if the course or instructors are no longer approved. Also, a license to provide MRE shall be canceled if the sponsor does not comply with this chapter.

[ARC 5204C, IAB 10/7/20, effective 11/11/20]

These rules are intended to implement Iowa Code sections 321.179 and 321.180B(5).

[Filed 2/11/98, Notice 12/31/97—published 3/11/98, effective 4/15/98]

[Filed 8/7/02, Notice 6/26/02—published 9/4/02, effective 10/9/02]

[Filed 3/10/04, Notice 2/4/04—published 3/31/04, effective 5/5/04]

[Filed 1/12/05, Notice 12/8/04—published 2/2/05, effective 3/9/05]

[Filed 10/11/06, Notice 8/30/06—published 11/8/06, effective 12/13/06]

[Filed 12/12/07, Notice 11/7/07—published 1/2/08, effective 2/6/08]

[Filed ARC 3452C (Notice ARC 3305C, IAB 9/13/17), IAB 11/8/17, effective 12/13/17]

[Filed ARC 5204C (Notice ARC 5102C, IAB 7/29/20), IAB 10/7/20, effective 11/11/20]

[Editorial change: IAC Supplement 12/28/22]

CHAPTER 636  
MOTORIZED BICYCLE RIDER EDUCATION

**761—636.1(321) Information and location.** Applications, forms and information regarding this chapter are available by mail from the Motor Vehicle Division, Iowa Department of Transportation, P.O. Box 9204, Des Moines, Iowa 50306-9204; in person at 6310 SE Convenience Blvd., Ankeny, Iowa; by telephone at (515)244-8725; or by facsimile at (515)239-1837.

[ARC 5258C, IAB 11/4/20, effective 12/9/20; Editorial change: IAC Supplement 12/28/22]

**761—636.2(321) Definitions.**

“*Approved course*” means the motorized bicycle rider education course approved by the department.

“*Instructor*” means a person approved by the department to instruct a motorized bicycle rider education course.

“*Program approval*” means department approval of an entity’s motorized bicycle rider education course and instructors.

“*Sponsor*” means an entity that delivers the approved course.

[ARC 5258C, IAB 11/4/20, effective 12/9/20]

**761—636.3** Reserved.

**761—636.4(321) Approved program in motorized bicycle rider education.**

**636.4(1) *Program approval.*** Any entity planning to offer a motorized bicycle rider education course must receive program approval from the department prior to the beginning of the first class that is offered and annually thereafter.

**636.4(2) *Application and fees.*** Application for initial program approval or annual program approval renewal shall be made to the department in a manner determined by the department. The application fee is \$25 for a private or commercial sponsor. The fee must be paid by cash, money order or check unless the department approves payment of the fee by electronic means. A money order or check must be for the exact amount and should be made payable to the Treasurer, State of Iowa, or the Department of Transportation.

**636.4(3) *Initial program approval and annual renewal.*** Program approval to provide motorized bicycle rider education shall be issued for a calendar year or remainder of a calendar year. The program approval expires on December 31 but remains valid for an additional 30 days after the expiration date. The application for renewal shall be submitted to the department within 60 days of the expiration date, unless otherwise approved by the department.

**636.4(4) *Cancellation and denial.*** The department shall cancel or deny program approval if the course or instructors are no longer approved.

[ARC 5258C, IAB 11/4/20, effective 12/9/20]

**761—636.5(321) Course requirements.**

**636.5(1) *Classroom instruction.*** An approved course shall consist of a minimum of six clock hours of classroom instruction which includes the instructional components contained in subrule 636.5(3).

**636.5(2) *Driving instruction.*** Motorized bicycle rider driving experiences in addition to classroom instruction are permissible, but not required.

**636.5(3) *Course content.*** The following instructional components shall be incorporated in every motorized bicycle rider education course.

*a. Operator and motorized bicycle preparation.*

- (1) Knowledge of Iowa driving laws.
- (2) Knowledge of vehicle registration requirements.
- (3) Vehicle inspection.
- (4) Protective clothing and devices.
- (5) Risk assessment.
- (6) Route selection.

*b. Basic control skills.*

- (1) Starting procedures.
- (2) Speed control.
- (3) Turning.
- (4) Stopping.

*c. Safe driving practices.*

- (1) Use of lights and warning devices.
- (2) Signaling.

- (3) Maintaining directional control.
- (4) Perception skills and observation.
- (5) Use of mirrors.
- (6) Recognition of hazards.
- (7) Speed control.
- (8) Lane positioning.
- (9) Concerns and conflicts regarding intersections.
- (10) Following distances.
- (11) Lateral separation.
- d. Complex situations.*
  - (1) Limited visibility.
  - (2) Adverse weather.
  - (3) Critical situations.
  - (4) Malfunctions.
- e. Motorized bicycle care.*
  - (1) Inspection.
  - (2) Maintenance.

[ARC 5258C, IAB 11/4/20, effective 12/9/20]

**761—636.6(321) Instructor approval.** An instructor of an approved motorized bicycle rider education course must be listed on the application for program approval as provided in subrules 636.4(1) and 636.4(2) and approved by the department.

**636.6(1) Instructor qualifications.** An instructor of an approved course shall possess a valid driver's license allowing unaccompanied driving other than a temporary restricted license and shall be able to operate a motorized bicycle. An instructor must also have a clear driving record for the previous two years. A clear driving record means the instructor has:

- a.* Not been identified as a candidate for driver's license suspension under the habitual violator provisions of rule 761—615.13(321) or the serious violation provisions of rule 761—615.17(321).
- b.* No driver's license suspensions, revocations, denials, cancellations, disqualifications or bars.
- c.* Not committed an offense that would result in driver's license suspension, revocation, denial, cancellation, disqualification or bar.
- d.* No record of a law enforcement investigative report indicating a contributive motor vehicle accident that caused the death or serious injury of another person.
- e.* No record of a law enforcement investigative report indicating two or more contributive motor vehicle accidents in a two-year period.

**636.6(2) Cancellation and denial.** When an instructor of an approved program does not meet the qualifications under this chapter, the department shall remove the instructor from the approved program and cancel or deny the approval of the program unless the entity has submitted an application for or secured approval of an alternate instructor from the department.

[ARC 5258C, IAB 11/4/20, effective 12/9/20]

**761—636.7(321) Evaluation.** Each student shall be evaluated by the instructor to determine successful completion of the course.

[ARC 5258C, IAB 11/4/20, effective 12/9/20]

These rules are intended to implement Iowa Code section 321.189.

[Filed 3/10/04, Notice 2/4/04—published 3/31/04, effective 5/5/04]

[Filed 12/12/07, Notice 11/7/07—published 1/2/08, effective 2/6/08]

[Filed ARC 5258C (Notice ARC 5154C, IAB 8/26/20), IAB 11/4/20, effective 12/9/20]

[Editorial change: IAC Supplement 12/28/22]

CHAPTERS 637 to 639  
Reserved



CHAPTER 640  
FINANCIAL RESPONSIBILITY  
[Prior to 6/3/87, Transportation Department[820]—(07,C)Ch 14]

**761—640.1(321A) General provisions.**

**640.1(1) Definitions.** The definitions contained in Iowa Code section 321A.1 are hereby adopted. In addition:

“*Department*” means the Iowa department of transportation.

“*Security*” means an amount of money sufficient in the determination of the department to satisfy any judgment or judgments for damages resulting from the accident as may be recovered against the operator or owner. Security is subject to the limitations and requirements of Iowa Code sections 321A.5 and 321A.9.

**640.1(2) Exceptions.** Except for accident reporting requirements, this chapter of rules does not apply to the owners or operators of motor vehicles excepted by Iowa Code section 321A.33. To establish availability of an exception, the person required to show proof shall submit to the department a letter from the owner of the motor vehicle authorizing the person to use the motor vehicle.

**640.1(3) Submissions and information.** Except as otherwise provided in this chapter, required submissions shall be either mailed to the Motor Vehicle Division, Iowa Department of Transportation, P.O. Box 9204, Des Moines, Iowa 50306-9204; delivered in person to 6310 SE Convenience Blvd., Ankeny, Iowa; or sent by facsimile to (515)239-1837. Information about the motor vehicle financial responsibility law in Iowa Code chapter 321A is available from these sources or by telephone at (515)244-8725.

This rule is intended to implement Iowa Code sections 17A.3, 321A.1 and 321A.33.

[ARC 4803C, IAB 12/4/19, effective 1/8/20; ARC 7008C, IAB 5/3/23, effective 6/7/23]

**761—640.2(321A) Hearing and appeal process.** A person who is aggrieved by an action of the department implementing Iowa Code sections 321A.4 to 321A.11 may contest the action in accordance with rule 761—615.38(17A,321). The administrative law judge in a contested case hearing may subpoena witnesses and conduct any investigation deemed necessary to:

**640.2(1)** Determine if the person is properly identified with the accident.

**640.2(2)** Determine if there is any reasonable possibility that judgment could be rendered against the person.

**640.2(3)** Determine if the person is entitled to any exceptions provided by law.

**640.2(4)** Determine if the security required following an accident is reasonable and make adjustments deemed necessary or proper.

This rule is intended to implement Iowa Code chapter 17A and section 321A.2.

**761—640.3(321A) Accident reporting requirements.** Accident reporting requirements are specified in Iowa Code section 321.266 and on Form 433002, “Iowa Accident Report Form,” which is available from law enforcement officers, driver’s license service centers, or from the motor vehicle division at the address in subrule 640.1(3).

This rule is intended to implement Iowa Code sections 321.266, 321.269 and 321A.4.

[ARC 4803C, IAB 12/4/19, effective 1/8/20; ARC 7008C, IAB 5/3/23, effective 6/7/23]

**761—640.4(321A) Security required following accident.** Following an accident, security is required pursuant to Iowa Code section 321A.5. For the purposes of determining the 60-day time frame under Iowa Code section 321A.5(1), a “report of a motor vehicle accident” includes a new or amended law enforcement officer accident report submitted to the department under Iowa Code section 321.266(3); a new or amended driver accident report, Form 433002, submitted to the department under Iowa Code section 321.266(2); any supplemental report submitted to the department under Iowa Code section 321.267; proof of transfer of ownership of a vehicle involved in the accident that occurred prior to the date of the accident; proof of identity of a driver incorrectly identified in an initial accident report; or proof of loss submitted by an insurance carrier authorized to transact insurance business in Iowa or its authorized subrogation provider. Nothing in this rule shall be construed to extend the duration of a suspension issued under Iowa Code section 321A.5 beyond the period authorized in Iowa Code section 321A.7.

**640.4(1) Suspension.**

*a.* If the security requirements of Iowa Code section 321A.5 are not met, the department shall suspend all licenses of the driver and all registrations of the owner.

*b.* The suspension shall become effective 30 days after a suspension notice is served pursuant to rule 761—615.37(321). The notice shall inform the person of the amount of security required. The duration of the suspension is provided in Iowa Code section 321A.7. When the suspension ends, the department shall issue to the person a notice terminating the suspension.

**640.4(2) Reserved.**

**640.4(3) Security—amounts and type.**

a. The amount of security required of the uninsured driver and owner shall be determined from reports of the drivers involved in the accident, reports of investigating officers and from supplemental information obtained from persons involved in the accident concerning amounts of damage and injury sustained. Form 431074, "Insurance Request Letter," may be mailed to parties to the accident for supplemental information. The security required shall not be increased after the suspension notice has been served, but may be reduced if evidence of exact costs is submitted to the department. The amount of security shall not exceed the minimum limits of liability for death or injury specified in Iowa Code chapter 321A.

b. The security shall be deposited with the department at the address in subrule 640.1(3). The department shall issue to the depositor a receipt when the security is received. Security shall be one of the following types:

- (1) Cash.
- (2) Cashier's check, certified check, bank draft, or postal money order payable to: Treasurer, State of Iowa.
- (3) Surety bond issued by a company authorized to transact insurance business in Iowa.

**640.4(4) Security disposition.**

a. Security is held by the state treasurer and can be released only for payment of a judgment or as otherwise provided in Iowa Code section 321A.10; or by a court, including by Form 431097, "Order for Release of Security"; or by Form 433010, "Assignment and Release."

b. The security can be refunded at any time as follows:

(1) When compliance as provided in subrule 640.4(5) is presented to the motor vehicle division at the address in subrule 640.1(3); or

(2) When, after one year has elapsed from the date of the accident, Form 433007, "Affidavit for Reinstatement or Refund of Security," is completed by the depositor, the form indicates that no action has been initiated or judgment rendered, and the form is submitted to the motor vehicle division. Upon receipt of the form, the motor vehicle division may confirm the facts contained therein with the district court of the county where the accident occurred or any other court of competent jurisdiction.

**640.4(5) Exceptions to requirement of security.** A person who meets the requirements under Iowa Code section 321A.6(1) or 321A.6(2) is exempt from security requirements. A person who qualifies for an exception under Iowa Code section 321A.6(3), 321A.6(4) or 321A.7(3) must submit proof to the department at the address in subrule 640.1(3) showing that the person qualifies for the applicable exception as follows:

a. *General release from liability.* To qualify for this exception, a person shall submit Form 431036, "General Release." The signature of the party giving the release shall be notarized or witnessed by a disinterested person. The release shall be accompanied by a power of attorney or subrogation authority if signed by a person other than the party sustaining damage or injury. If the party giving release is a minor, the release shall be signed by the parent or legal guardian of the minor. The department may accept an equivalent alternative form to prove a person's general release from liability.

b. *Duly acknowledged written agreement release.* To qualify for this exception, a person shall submit Form 181301, "Agreement." Complete information shall be provided on the form including the total amount of settlement agreed upon by the parties involved and a release of liability upon fulfillment of payments. The signatures of all parties to the agreement shall be notarized. The release shall be accompanied by a power of attorney or subrogation authority if signed by a person other than a party sustaining damage or injury. If the party giving release is a minor, the release shall be signed by the parent or legal guardian of the minor. This documentation demonstrates compliance only for a party who has agreed to make payment and whose signature appears on the agreement release. The department may accept an equivalent alternative form to prove that a person has executed a duly acknowledged written agreement.

c. *Court-certified confession of judgment.* To qualify for this exception, a person shall submit a court-certified copy of a confession of judgment, which must include the total sum to be paid, the payment schedule agreed to by the parties, the signature of both parties, and proof of loss if the judgment is to be paid to a subrogation authority.

d. *Accord and satisfaction.* To qualify for this exception, a person shall submit documentation that one party to an accident or the party's insurance carrier has accepted liability for the accident and has compensated the other party to the accident for damages and injuries. This documentation does not demonstrate compliance for a third party.

e. *Covenant not to sue.* To qualify for this exception, a person shall submit documentation of a covenant not to sue that is given to a party to an accident as compliance by another party to the accident when a release would damage any claim against a third party.

f. *Proof of no-fault or no reasonable possibility of judgment.* To qualify for this exception, a person shall submit proof that the person is not at fault for the accident or that there is no reasonable possibility of judgment being rendered against a person in any of the following ways:

- (1) The investigating officer's report of the accident indicates the other driver caused the accident.

- (2) The other driver admits causing the accident.
- (3) Witness statements indicate the other driver caused the accident.
- (4) The other driver is convicted of a violation which caused the accident.

*g. Adjudication of nonliability.* To qualify for this exception, a person shall submit a certified copy of a final court judgment that is rendered in a civil damage action resulting from the accident and that relieves the person of any obligation to pay damages.

*h. Bankruptcy.* To qualify for this exception, a person shall submit a copy of the decree for bankruptcy showing that all possible claims against the person arising from the accident have been scheduled in the bankruptcy decree.

*i. Owner exception under Iowa Code section 321A.6(3).* To qualify for this exception, a vehicle owner shall submit documentation that the vehicle was being operated at the time of an accident without the owner's permission, express or implied. This exception does not apply to a person who was driving the vehicle at the time of the accident. Acceptable documentation includes the following:

- (1) A police report indicating the vehicle was stolen.
- (2) Proof of the driver's conviction of operating the vehicle without the owner's consent at the time of the accident.
- (3) A sworn affidavit that the vehicle was being operated without permission at the time of the accident.
- (4) A witness affidavit that the driver had been denied use of the vehicle.

*j. Owner exception for vehicle sale.* To qualify for this exception, a vehicle owner shall submit documentation that the vehicle owner had sold the vehicle involved in the accident and the title had been reassigned to the new owner, but departmental records did not yet show that the title had been transferred when the accident occurred. This exception does not apply to a person who was driving the vehicle at the time of the accident. Acceptable documentation includes the following:

(1) Form 431125, "Affidavit of Seller," completed by both the buyer and seller with signatures notarized or attested to by a member of the department, unless the seller certifies under penalty of perjury that the buyer's signature could not be obtained and provides evidence to the satisfaction of the department that supports this certification.

(2) A sworn affidavit by the seller and witnesses to the sale, if any, that the vehicle had been sold, including a description of the vehicle, the date of the sale, the monetary consideration, facts concerning the assignment of title and delivery of possession, and the names of witnesses to the sale, if any.

*k. Owner exception for vehicle transfer.* To qualify for this exception, a vehicle owner shall submit certified copies of any court order by which ownership of a vehicle was awarded to another party prior to the date of the accident. This exception does not apply to a person who was driving the vehicle at the time of the accident.

This rule is intended to implement Iowa Code sections 321A.4 to 321A.11 and 321A.31.

[ARC 4803C, IAB 12/4/19, effective 1/8/20; ARC 7008C, IAB 5/3/23, effective 6/7/23]

**761—640.5(321A) Judgments.** A suspension of license and registrations is required under Iowa Code section 321A.13 when the department receives from the clerk of court a certification of judgment which has remained unsatisfied for at least 60 days pursuant to Iowa Code section 321A.12. Form 431126, "Certification of Judgment," may be used by the clerk of court to report a certified judgment to the department.

**640.5(1) Suspension.** The suspension becomes effective on the date the suspension notice is served pursuant to rule 761—615.37(321). The notice shall inform the person that the privilege to operate and register motor vehicles in Iowa is suspended until the judgment is satisfied and proof of financial responsibility is shown. The duration of the suspension is provided in Iowa Code section 321A.14. When the suspension ends, the department shall issue to the person a notice terminating the suspension.

**640.5(2) Suspension—exceptions.** A person who qualifies for an exception under Iowa Code section 321A.13, 321A.14 or 321A.16 must submit proof to the department at the address in subrule 640.1(3) that the person qualifies for the applicable exception in one of the following ways:

*a. Creditor's consent.* To qualify for this exception, the judgment debtor must obtain written consent from the judgment creditor for issuance of the debtor's license and registrations while paying the judgment. If this consent is withdrawn, a new suspension is required in accordance with subrule 640.5(1).

*b. Satisfaction of judgment.* To qualify for this exception, the judgment debtor must submit a certificate of satisfaction or receipt for payment of the judgment from the clerk of court.

*c. Bankruptcy.* To qualify for this exception, the judgment debtor must submit a copy of the decree for bankruptcy which includes the judgment debt.

*d. Court order for installment payments.* To qualify for this exception, the judgment debtor must submit a court order authorizing payment of the judgment in installments. A new suspension, as provided in subrule 640.5(1), is

required when the department receives notice of a default in the payments. The default suspension shall continue until the judgment is satisfied or a new court order authorizing payment of the judgment in installments is received.

*e. Insurance coverage exception.* To qualify for this exception, the judgment debtor who held effective liability insurance coverage at the time of the accident from which the judgment was rendered shall submit a copy of the insurance policy and a letter from the insurance carrier confirming that the insurance carrier was authorized to issue liability insurance, that the insurance carrier did provide coverage for the debtor in amounts required by the financial responsibility law, and the reason why the insurance carrier has not paid such judgment.

This rule is intended to implement Iowa Code sections 321A.12 to 321A.29 and 321A.31.

[ARC 4803C, IAB 12/4/19, effective 1/8/20; ARC 7008C, IAB 5/3/23, effective 6/7/23]

**761—640.6(321A) Proof of financial responsibility.** Proof of financial responsibility is required pursuant to Iowa Code sections 321A.13, 321A.14, 321A.16 and 321A.17. A person's driver's license or nonresident operating privilege shall remain suspended or revoked until the person has filed proof of financial responsibility with the department. In addition, a person's motor vehicle registrations shall remain suspended until the person has filed with the department proof of financial responsibility for all motor vehicles registered to that person.

**640.6(1) Duration of proof of financial responsibility.** Proof of financial responsibility is required for two years starting on the effective date of the person's last suspension or revocation that qualifies under Iowa Code section 321A.17. The requirement terminates if the person required to give proof dies or becomes incapable of operating a motor vehicle, or surrenders the driver's license and the plates of all vehicles registered in the person's name to the department. Reinstatement of the person's driver's license or nonresident operating privilege and motor vehicle registrations within the two-year requirement is possible only if the person refiles such proof.

**640.6(2) Methods of giving proof of financial responsibility.**

*a.* Proof of financial responsibility may be shown by a liability insurance certificate pursuant to Iowa Code section 321A.19. Form SR-22, "AAMVA Uniform Financial Responsibility Form," is required as the form of the certificate except when proof of financial responsibility is submitted electronically in a format approved by the department. The form may describe an owner's or operator's policy and shall identify the policyholder by name, address, driver's license number and birth date. The effective date of the policy shall be the same as the effective date on the form. The vehicles covered shall be identified by year, make, model and vehicle identification number. The form shall be certified in accordance with the Iowa financial responsibility law by an insurance carrier authorized to transact insurance business in Iowa or by an insurance carrier authorized by power of attorney. The policy shall be canceled only as provided in Iowa Code section 321A.22. Certification of coverage for an owner's policy authorizes the policyholder to have registrations for the described vehicles. Certification of coverage for an operator's policy does not authorize registrations.

*b.* Proof of financial responsibility may be given for a person who is an operator in the employ of the owner of the motor vehicle, or who is a member of the immediate family or household of the owner pursuant to Iowa Code section 321A.26, if the owner's insurance carrier certifies for the person required to show proof of financial responsibility. In addition to the requirements in paragraph 640.6(2)"a," the proof of financial responsibility shall identify both the policyholder and the person for whom proof of financial responsibility is given. This certification does not authorize the person required to give proof of financial responsibility to register a motor vehicle.

*c.* Proof of financial responsibility may be given for a person who is an operator in the employ of an owner of a fleet of motor vehicles, if the owner's insurance carrier certifies for the person required to show proof of financial responsibility. Form SR-23, "AAMVA Uniform Financial Responsibility Form," is required as the form of the certificate except when proof of financial responsibility is submitted electronically in a format approved by the department. The form shall identify the policyholder's name and address, policy number, policy dates and effective date. This certification does not authorize the person required to give proof of financial responsibility to register a motor vehicle.

*d.* Proof of financial responsibility may be given for a person who is an operator in the employ of an owner who has qualified as a self-insurer pursuant to Iowa Code section 321A.34. A certificate of self-insurance may be issued by the department to a person in whose name more than 25 vehicles are registered and who submits a financial statement which is found to be satisfactory to the department. Form SR-1, "Application for Self Insurance," shall be completed and submitted to the department with a list of all the owner's motor vehicles registered in Iowa identified by make, year, model and vehicle identification number. When the application is approved, the department shall issue Form SR-2, "Self Insurance Certificate." Failure to pay a judgment pursuant to Iowa Code section 321A.34 or failure to submit an annual financial statement shall be reasonable grounds for cancellation of the certificate.

**640.6(3) Proof of financial responsibility restriction.** When a person has filed satisfactory proof of financial responsibility in accordance with subrule 640.6(2), and the person applies for and is otherwise eligible for a driver's

license, the department shall issue the driver's license with a restriction indicating that the person is subject to proof of financial responsibility requirements. The restriction code shall be the same as described in 761—subrule 605.8(1).

**640.6(4)** *Terminating the suspension upon filing of proof of financial responsibility.* When proof of financial responsibility is provided under subrule 640.6(2) and the person is otherwise eligible for licensing or registration, the department shall issue a notice terminating the suspension to the person whose privileges were suspended under Iowa Code section 321A.13, 321A.14, 321A.16 or 321A.17 or rule 761—640.5(321A) or 761—640.6(321A). To regain operating privileges, the person shall pass the required examinations and pay the required fees. The person's operating and registration privileges are restricted to the motor vehicles covered under the proof of financial responsibility filed by the applicant, except that a person required to give proof of financial responsibility who holds proof of financial responsibility as an operator may operate a nonowned vehicle provided the owner of that vehicle has liability coverage required under Iowa Code chapter 321A.

**640.6(5)** *Cancellation of proof of financial responsibility.* An insurance carrier shall only cancel or terminate a certificate of insurance pursuant to Iowa Code section 321A.22. The cancellation shall be certified by an authorized insurance carrier representative on Form SR-26, "AAMVA Uniform Financial Responsibility Form," except when cancellation of proof of financial responsibility is submitted electronically in a format approved by the department. The cancellation of proof of financial responsibility shall identify the proof of financial responsibility certificate to be canceled by name and address of the person, social security number, birth date, driver's license number, number of the policy to be canceled and the effective date of cancellation.

**640.6(6)** *Suspension when proof of financial responsibility is canceled.*

*a.* When a person's proof of financial responsibility is canceled, the person shall immediately refile proof of financial responsibility or surrender the license and registrations to the department.

*b.* If the person fails to refile proof of financial responsibility, a suspension notice shall be served in accordance with rule 761—615.37(321). The effective date of the suspension shall be the date the notice is served. The notice shall inform the person that the privilege to operate and register motor vehicles in Iowa is suspended until proof of financial responsibility is refiled. When the person refiles proof of financial responsibility, the department shall issue to the person a notice terminating the suspension.

**640.6(7)** *Terminating the proof of financial responsibility requirement.* A notice terminating the requirement to maintain proof of financial responsibility shall be issued to a person who has satisfied proof of financial responsibility requirements pursuant to Iowa Code section 321A.29. The form shall notify the person that proof of financial responsibility is no longer required and that the person may operate and register motor vehicles without maintaining and filing with the department proof of financial responsibility. If the person's driver's license is still valid, the person may obtain a duplicate driver's license without the restriction under subrule 640.6(3). If the driver's license has expired or has not been reinstated and the person is otherwise eligible for licensing, the person shall pass the required examinations and pay the required fees.

**640.6(8)** *Electronic submission of proof of financial responsibility and cancellation of proof of financial responsibility.* Prior to July 1, 2021, an insurance carrier authorized to transact business in the state of Iowa may electronically submit proof of financial responsibility and cancellation of proof of financial responsibility in a format approved by the department. An insurance carrier that submits proof of financial responsibility or cancellation of proof of financial responsibility under this rule shall implement electronic submission of such proof no later than July 1, 2021. As of July 1, 2021, no paper submissions of such proof shall be accepted by the department from the insurance carrier, and all submissions of proof of financial responsibility and cancellation of proof of financial responsibility shall be submitted electronically in a format approved by the department.

This rule is intended to implement Iowa Code sections 321A.12 to 321A.29, 321A.31 and 321A.34.

[ARC 7902B, IAB 7/1/09, effective 8/5/09; ARC 4803C, IAB 12/4/19, effective 1/8/20; ARC 7008C, IAB 5/3/23, effective 6/7/23]

**761—640.7(321A) Transfer of suspended registration.** A person whose motor vehicle registration privileges have been suspended may make a bona fide sale pursuant to Iowa Code sections 321.493 and 321A.30. The department shall release the suspended registration to permit the registration of the motor vehicle by the purchaser when presented with either the seller's sworn statement on Form 411107, "Notice of Sale of Vehicle and Delivery of Title," or confirmation from the county treasurer that the sale has been made and release of the registration is necessary to complete the transfer of title.

This rule is intended to implement Iowa Code sections 321.493 and 321A.30.

[ARC 7008C, IAB 5/3/23, effective 6/7/23]

[Filed 7/1/75; emergency amendment, filed 8/12/75—published 8/25/75, effective 8/15/75]

[Filed 2/26/80, Notice 1/9/80—published 3/19/80, effective 4/23/80]

[Filed 12/17/80, Notice 10/29/80—published 1/7/81, effective 2/11/81]

[Filed emergency 8/19/81—published 9/16/81, effective 8/21/81]  
[Filed emergency 5/27/82—published 6/23/82, effective 7/1/82]  
[Filed 12/1/82, Notice 6/23/82—published 12/22/82, effective 1/26/83]  
[Filed 12/1/82, Notice 10/13/82—published 12/22/82, effective 1/26/83]  
[Filed 1/9/85, Notice 11/21/84—published 1/30/85, effective 3/6/85]  
[Filed 4/17/85, Notice 2/27/85—published 5/8/85, effective 6/12/85]  
[Filed 11/27/85, Notice 10/9/85—published 12/18/85, effective 1/22/86]  
[Filed 5/11/87, Notice 3/11/87—published 6/3/87, effective 7/8/87]  
[Filed 11/3/88, Notice 9/21/88—published 11/30/88, effective 1/4/89]  
[Filed emergency 11/30/89—published 12/27/89, effective 12/1/89]  
[Filed 12/18/91, Notice 11/13/91—published 1/8/92, effective 2/12/92]  
[Filed 11/1/95, Notice 9/27/95—published 11/22/95, effective 12/27/95]  
[Filed 10/30/96, Notice 9/25/96—published 11/20/96, effective 12/25/96]  
[Filed 6/19/02, Notice 4/17/02—published 7/10/02, effective 8/14/02]  
[Filed 12/12/07, Notice 11/7/07—published 1/2/08, effective 2/6/08]  
[Filed ARC 7902B (Notice ARC 7721B, IAB 4/22/09), IAB 7/1/09, effective 8/5/09]  
[Filed ARC 4803C (Notice ARC 4681C, IAB 10/9/19), IAB 12/4/19, effective 1/8/20]  
[Filed ARC 7008C (Notice ARC 6917C, IAB 2/22/23), IAB 5/3/23, effective 6/7/23]

CHAPTER 641  
FINANCIAL LIABILITY COVERAGE CARDS

**761—641.1(321) Purpose and applicability.**

**641.1(1)** The purpose of this chapter is to establish requirements for financial liability coverage cards.

**641.1(2)** This chapter applies to motor vehicles registered in Iowa or subject to registration in Iowa.

**641.1(3)** This chapter does not address proof of financial responsibility under Iowa Code chapter 321A except for the issuance of financial liability coverage cards.

**641.1(4)** Proof of financial liability coverage for motor vehicle dealers is addressed in 761—subrule 425.10(8).

**761—641.2(321) Definitions.**

*“Fleet”* means five or more motor vehicles covered under an insurance policy, or one or more motor vehicles covered by a bond filed under Iowa Code section 321A.24, a security certificate issued under section 321A.25, or a self-insurance certificate issued under section 321A.34.

*“Registration number”* as used in Iowa Code sections 321.20B, 321A.24(1) and 321A.25(1) means vehicle identification number.

[Editorial change: IAC Supplement 8/11/21]

**761—641.3(321) Content of financial liability coverage card.**

**641.3(1)** A financial liability coverage card issued by an insurance company for a motor vehicle that is not insured as a part of a fleet shall contain the following information:

*a.* Either one of the following:

(1) Name and address of insurer.

(2) Name of insurer and name and address of insurance agency.

*b.* Name of insured.

*c.* Policy number.

*d.* Vehicle identification number of the insured motor vehicle.

*e.* Year and make of the insured motor vehicle.

*f.* The statement, “Coverage provided by this policy meets the minimum liability limits prescribed by law,” or a statement that is substantially similar.

*g.* Effective and expiration dates of coverage.

*h.* The statement, “This card must be carried in the insured motor vehicle at all times,” or a statement that is substantially similar.

*i.* An emergency telephone number of either the insurer or the insurance agency.

**641.3(2)** An insurance company shall issue a financial liability coverage card for each motor vehicle insured as a part of a fleet. The fleet owner shall maintain a card in each fleet vehicle. The card shall contain the following information:

*a.* Either one of the following:

(1) Name and address of insurer.

(2) Name of insurer and name and address of insurance agency.

*b.* Name of insured.

*c.* Policy number.

*d.* Either the vehicle identification number or the words “all owned vehicles” or the word “fleet.”

*e.* The statement, “Coverage provided by this policy meets the minimum liability limits prescribed by law,” or a statement that is substantially similar.

*f.* Effective and expiration dates of coverage.

*g.* The statement, “This card must be carried in the insured motor vehicle at all times,” or a statement that is substantially similar.

*h.* An emergency telephone number of either the insurer or the insurance agency.

**641.3(3)** One financial liability coverage card shall be issued by the department for each fleet covered by a bond filed under Iowa Code section 321A.24, a security certificate issued under section 321A.25, or a self-insurance certificate issued under section 321A.34. The fleet owner shall maintain a copy of the card in each fleet vehicle. The card shall contain the following information:

*a.* Name, address and telephone number of person to whom the card is issued.

*b.* Number assigned by the department.

*c.* Either the vehicle identification number or the words “all owned vehicles” or the word “fleet.”

d. The statement, "This card must be carried in the covered motor vehicle at all times."

**761—641.4(321) Responsibilities of insurer.**

**641.4(1)** Each insurer issuing financial liability coverage in this state shall furnish a financial liability coverage card that complies with these rules to the named insured for each motor vehicle insured. The card shall be provided with every new policy and every policy renewal issued.

**641.4(2)** The insurer shall file a true and correct, sample copy of its financial liability coverage card with the Iowa insurance division.

**761—641.5(321) Acquisition of additional or replacement motor vehicles.**

**641.5(1)** A financial liability coverage card that provides coverage for a replacement motor vehicle may be used temporarily in a replacement motor vehicle for 30 days if ownership evidence as described in 761—subrule 400.19(3) is carried in the motor vehicle.

**641.5(2)** A copy of a financial liability coverage card that provides coverage for an additionally acquired motor vehicle may be used temporarily in an additionally acquired motor vehicle for 30 days if ownership evidence as described in 761—subrule 400.19(3) is carried in the motor vehicle.

**761—641.6(321) New policies.** On new policy applications, a binder of liability coverage issued by an insurance agent authorized to conduct insurance business in this state is acceptable proof of financial liability coverage for a period of 30 days from date of issue of the binder.

These rules are intended to implement Iowa Code sections 321.1, 321.20B, 321A.24, 321A.25, and 321A.34.

[Filed 12/17/97, Notice 11/5/97—published 1/14/98, effective 2/18/98]

[Filed 10/28/98, Notice 9/23/98—published 11/18/98, effective 12/23/98]

[Filed 6/19/02, Notice 4/17/02—published 7/10/02, effective 8/14/02]

[Editorial change: IAC Supplement 8/11/21]

CHAPTERS 642 to 699  
Reserved



AERONAUTICS  
CHAPTER 700  
AERONAUTICS ADMINISTRATION

**761—700.1(328) Definitions.** The definitions in Iowa Code section 328.1 and the following definitions shall apply to 761—Chapters 700 to 799.

“*FAA*” means the Federal Aviation Administration.

“*Sponsor*” means the person or governmental subdivision that has the authority for improving, maintaining and operating an aviation facility.

This rule is intended to implement Iowa Code section 328.1.

[ARC 1351C, IAB 3/5/14, effective 4/9/14]

**761—700.2(17A) Information and forms.** Program information, forms and application instructions are available on the department’s website at [www.iowadot.gov](http://www.iowadot.gov). Requests for such materials or assistance may also be made by calling the office of aviation at (515)239-1048. Submission of application materials shall be made according to the annual application instructions included in the application materials. The office of aviation mailing address is: Office of Aviation, Iowa Department of Transportation, 800 Lincoln Way, Ames, Iowa 50010.

This rule is intended to implement Iowa Code section 17A.3.

[ARC 1351C, IAB 3/5/14, effective 4/9/14; ARC 3880C, IAB 7/4/18, effective 8/8/18]

**761—700.3(17A) Hearing and appeal process.** A person who has been aggrieved by a decision of the department and who is entitled to a hearing may contest the decision in accordance with 761—Chapter 13, Iowa Administrative Code.

This rule is intended to implement Iowa Code chapter 17A.

[Filed 9/2/87, Notice 7/15/87—published 9/23/87, effective 10/28/87]

[Filed 1/15/92, Notice 12/11/91—published 2/5/92, effective 3/11/92]

[Filed emergency 7/1/92—published 7/22/92, effective 7/27/92]

[Filed 12/17/03, Notice 11/12/03—published 1/7/04, effective 2/11/04]

[Filed ARC 1351C (Notice ARC 1270C, IAB 1/8/14), IAB 3/5/14, effective 4/9/14]

[Filed ARC 3880C (Notice ARC 3755C, IAB 4/25/18), IAB 7/4/18, effective 8/8/18]



CHAPTERS 701 to 709  
Reserved



CHAPTER 710  
AIRPORT IMPROVEMENT PROGRAM  
[Prior to 6/3/87, Transportation Department [820]—(04,B) Ch 1]

**761—710.1(328) Purpose.** These rules establish the procedures for a governmental subdivision to apply for state or federal funds for the improvement of airports and air navigation facilities.

This rule is intended to implement Iowa Code sections 328.12 and 330.13.

**761—710.2(328) Definitions.** The definitions in Iowa Code sections 328.1, 330.1, and 330A.2 apply to this chapter of rules.

This rule is intended to implement Iowa Code sections 328.1, 330.1, and 330A.2.

**761—710.3(17A) Information and forms.** Program information, forms and application instructions are available on the department's website at [www.iowadot.gov](http://www.iowadot.gov). Requests for such materials or assistance may also be made by calling the office of aviation at (515)239-1048. Submission of application materials shall be made according to the annual application instructions included in the application materials. The office of aviation mailing address is: Office of Aviation, Iowa Department of Transportation, 800 Lincoln Way, Ames, Iowa 50010.

This rule is intended to implement Iowa Code section 17A.3.

[ARC 1351C, IAB 3/5/14, effective 4/9/14; ARC 3880C, IAB 7/4/18, effective 8/8/18]

**761—710.4(330) Federal airport improvement funds.**

**710.4(1) Applicant eligibility.** A governmental subdivision owning a public airport that is listed in the Federal Aviation Administration's (FAA) National Plan of Integrated Airport Systems (NPIAS) is eligible to apply for federal funds. The NPIAS published report is available at the FAA website: [www.faa.gov/airports](http://www.faa.gov/airports). An airport that receives federal primary commercial service entitlement funds is not required to submit preapplications.

**710.4(2) Project eligibility.** Projects must meet the FAA eligibility guidelines for federal airport improvement projects. Federal airport improvement program guidelines are available at the FAA website: [www.faa.gov/airports](http://www.faa.gov/airports).

**710.4(3) Preapplication.**

a. The department shall distribute preapplication instructions and forms annually to each eligible applicant.

b. The completed preapplication for federal airport improvement funds shall be submitted to the department according to the method and time frame specified in the annual application instructions.

**710.4(4) Project prioritization.**

a. The department shall review each completed preapplication for project eligibility and consistency with the state aviation system plan. The department shall review and prioritize projects based on the goals and objectives in the state aviation system plan.

b. The commission is responsible for approving the prioritization of the preapplications.

c. The department shall submit the preapplications with priorities identified to the FAA, and the FAA will contact the applicant directly concerning all subsequent action on the preapplication.

This rule is intended to implement Iowa Code section 330.13.

[ARC 1351C, IAB 3/5/14, effective 4/9/14]

**761—710.5(328) State airport improvement funds.**

**710.5(1) Applicant eligibility.** A governmental subdivision owning or establishing a public airport is eligible to apply to the department for state airport improvement funds.

**710.5(2) Project eligibility and funding.**

a. An airport improvement project must benefit and be accessible to the public.

b. Airport projects may include, but are not limited to: runway, taxiway, and apron surfaces; lighting and navigational aids; obstruction removal; grading, drainage, and surfacing airfield surfaces and protection areas; signage, security access control and lighting; planning; and other airport enhancements. A project that involves airfield infrastructure shall comply with the airport master plan or airport layout plan as adopted by the governmental subdivision.

c. The department establishes the maximum percentage of state share of eligible projects. The department may annually set a maximum dollar amount per award. Funding criteria are included in application instructions provided to airport sponsors.

**710.5(3) Application for funding.**

a. The department shall make available the application instructions and forms to each publicly owned airport in Iowa. A complete application will include all materials identified in the annual application instructions.

b. Project applications shall be submitted to the department by the due date specified in the instructions.

c. Immediate safety enhancement project applications may be submitted at any time during the year to the department according to instructions that are part of the application form.

d. The department shall make available applications for special projects to all eligible airports. Airport sponsors shall submit applications for special projects to the department as specified in the application instructions.

**710.5(4) Review and approval.** The department shall review each completed application and evaluate the impact of the project on the aviation system considering the following factors: state system plan airport roles, goals and objectives; justification provided in the application; ability to enhance aeronautical activity for the airport and system; local participation; and multijurisdictional support of the airport. The department shall recommend projects to the transportation commission for approval. The commission is responsible for approving the projects to be funded.

**710.5(5) Project administration.**

a. After a project has been approved by the commission, the department shall enter into an agreement with the airport sponsor that specifies the responsibilities of the sponsor.

b. The agreement shall specify the amount of state funds, the contract period, and the responsibilities for project planning, development, and the payment process.

c. The department may inspect the improvement for compliance with the agreement and may audit all project costs incurred.

**710.5(6) Contract payments.**

a. Payments to the airport sponsor for eligible project costs shall be made on a cost reimbursement basis.

b. Engineering fees are an eligible project expense and shall be reimbursed in compliance with the agreement.

This rule is intended to implement Iowa Code chapter 328.

[ARC 1351C, IAB 3/5/14, effective 4/9/14]

[Filed 7/1/75]

[Filed 5/11/87, Notice 3/11/87—published 6/3/87, effective 7/8/87]

[Filed 1/15/92, Notice 12/11/91—published 2/5/92, effective 3/11/92]

[Filed emergency 7/1/92—published 7/22/92, effective 7/27/92]

[Filed 3/10/94, Notice 1/5/94—published 3/30/94, effective 5/4/94]

[Filed 12/17/03, Notice 11/12/03—published 1/7/04, effective 2/11/04]

[Filed 12/14/05, Notice 11/9/05—published 1/4/06, effective 2/8/06]

[Filed ARC 1351C (Notice ARC 1270C, IAB 1/8/14), IAB 3/5/14, effective 4/9/14]

[Filed ARC 3880C (Notice ARC 3755C, IAB 4/25/18), IAB 7/4/18, effective 8/8/18]

CHAPTERS 711 to 714  
Reserved



CHAPTER 715  
AIR SERVICE DEVELOPMENT PROGRAM

**761—715.1(328) Purpose.** The purpose of the air service development program is to help commercial service airports sustain and enhance available air service options for the traveling public.

[ARC 1351C, IAB 3/5/14, effective 4/9/14]

**761—715.2(328) Definitions.** The definitions in Iowa Code section 328.1 and rule 761—700.1(328) shall apply to this chapter of rules.

**761—715.3(328) Eligibility and funding.**

**715.3(1)** Participation in the air service development program shall be limited to airports currently receiving scheduled air service and designated as commercial service airports in the Iowa aviation system plan.

**715.3(2)** The transportation commission shall establish annually:

- a. The maximum amount of funds to be allocated to the air service development program for the program year.
- b. The amount to be allocated to each airport for sustainment project activities.
- c. The amount of funds that will be added to the enhancement fund pool.

**715.3(3)** Program information, instructions and application forms may be obtained from the department's website at [www.iowadot.gov](http://www.iowadot.gov). Requests for such materials or assistance may also be made by calling the office of aviation at (515)239-1689. Submission of application materials shall be made according to the annual application instructions included in the application materials. The office of aviation mailing address is: Office of Aviation, Iowa Department of Transportation, 800 Lincoln Way, Ames, Iowa 50010.

**715.3(4)** Allocated program funds shall be available to each commercial service airport for the time period specified in the application instructions and in the agreement.

[ARC 1351C, IAB 3/5/14, effective 4/9/14; ARC 3880C, IAB 7/4/18, effective 8/8/18]

**761—715.4(328) Eligible project activities.** Activities that are eligible for reimbursement include, but are not limited to, the following:

**715.4(1)** Activities to sustain or improve air service, which include, but are not limited to, marketing, advocacy, educational efforts and leveraging local and federal funds in collection of data, studies or other efforts.

**715.4(2)** Service enhancement activities, which include, but are not limited to, market entry support, financial incentives and data analysis studies to help airports enhance service on new routes, provide for entry of a new carrier, or achieve an increase in seat capacity on existing routes.

[ARC 1351C, IAB 3/5/14, effective 4/9/14]

**761—715.5(328) Ineligible project activities.** Rescinded ARC 1351C, IAB 3/5/14, effective 4/9/14.

**761—715.6(328) Project selection criteria.** Sustainment projects at each commercial service airport that meet the eligibility criteria may be funded up to the limit of each airport's allocation. Enhancement project requests that meet program requirements may be funded if funding is available in the enhancement fund pool.

[ARC 1351C, IAB 3/5/14, effective 4/9/14]

**761—715.7(328) Application.** Completed applications shall be submitted to the department and include the information requested in the annual application instructions.

[ARC 1351C, IAB 3/5/14, effective 4/9/14]

**761—715.8(328) Project administration.**

**715.8(1) Agreement.** After a project application has been approved, the department shall enter into a project agreement with the airport sponsor that specifies the responsibilities of the sponsor. The agreement shall specify the amount of state funds, the contract period, the payment process, and the responsibilities for project planning, development, and reporting. The department may inspect the improvement for compliance with the agreement and may audit all project costs.

**715.8(2) Project payments.** Payments to the airport sponsor for eligible project costs shall be made on a cost reimbursement basis.

[ARC 1351C, IAB 3/5/14, effective 4/9/14]

These rules are intended to implement Iowa Code section 328.12.

[Filed emergency 9/25/87—published 10/21/87, effective 9/25/87]

[Filed 12/3/87, Notice 10/21/87—published 12/30/87, effective 2/3/88]

[Filed emergency 5/25/88—published 6/15/88, effective 7/1/88]

[Filed 10/19/89, Notice 9/6/89—published 11/15/89, effective 12/20/89]

[Filed 1/15/92, Notice 12/11/91—published 2/5/92, effective 3/11/92]

[Filed 11/19/92, Notice 10/14/92—published 12/9/92, effective 1/13/93]

[Filed 12/17/03, Notice 11/12/03—published 1/7/04, effective 2/11/04]

[Filed ARC 1351C (Notice ARC 1270C, IAB 1/8/14), IAB 3/5/14, effective 4/9/14]

[Filed ARC 3880C (Notice ARC 3755C, IAB 4/25/18), IAB 7/4/18, effective 8/8/18]

CHAPTER 716  
COMMERCIAL SERVICE VERTICAL INFRASTRUCTURE PROGRAM

**761—716.1(328) Purpose.** The purpose of the commercial air service vertical infrastructure program is to provide funding for improvements to the vertical infrastructure at Iowa's commercial air service airports. The source of funds is an appropriation from the Iowa general assembly.

**761—716.2(328) Definitions.** The definitions in Iowa Code section 328.1 and rule 761—700.1(328) apply to these rules. In addition:

*“Vertical infrastructure”* means the same as defined in Iowa Code section 8.57(5).

[ARC 1351C, IAB 3/5/14, effective 4/9/14; ARC 3880C, IAB 7/4/18, effective 8/8/18]

**761—716.3(328) Information and forms.** Program information, instructions, and forms are available on the department's website at [www.iowadot.gov](http://www.iowadot.gov). Requests for such materials or assistance may also be made by calling the office of aviation at (515)239-1048. Submission of application materials shall be made according to the annual application instructions included in the application materials. The office of aviation mailing address is: Office of Aviation, Iowa Department of Transportation, 800 Lincoln Way, Ames, Iowa 50010.

[ARC 1351C, IAB 3/5/14, effective 4/9/14; ARC 3880C, IAB 7/4/18, effective 8/8/18]

**761—716.4(328) Eligible airports.** Eligible airports are those Iowa airports currently receiving scheduled commercial air service.

**761—716.5(328) Eligible project activities.** Activities that are eligible for reimbursement include, but are not limited to, the following:

**716.5(1)** Terminal building construction or renovation including associated design, land acquisition, grading and foundation work.

**716.5(2)** Hangar construction or renovation including associated design, land acquisition, grading and foundation work.

**716.5(3)** Maintenance facility building construction or renovation including, but not limited to, associated design, land acquisition, grading and foundation work.

**761—716.6(328) Ineligible project activities.** Rescinded IAB 1/7/04, effective 2/11/04.

**761—716.7(328) Project application and review.**

**716.7(1)** Each airport shall submit an application with the project or projects it intends to accomplish with the allocated funding. The completed application shall include the information and documents identified in the application instructions. The complete application shall be submitted to the department according to the annual application instructions.

**716.7(2)** The department shall review projects for eligibility and recommend projects and funding levels to the transportation commission. Funding criteria are included in application instructions provided to airport sponsors.

**716.7(3)** The transportation commission is responsible for approving the projects to be funded.

[ARC 1351C, IAB 3/5/14, effective 4/9/14]

**761—716.8(328) Project administration.**

**716.8(1) Agreement.** After the projects are approved by the commission, the department shall enter into an agreement with the airport sponsor that specifies the responsibilities of the sponsor. The agreement shall specify the amount of state funds, the contract period, the payment process, and the responsibilities for project planning, development, and reporting. The department may inspect the improvement for compliance with the agreement and may audit all project costs.

**716.8(2) Payments.** Payments to the airport sponsor for eligible project costs shall be made on a cost reimbursement basis. Engineering fees are an eligible project expense and shall be reimbursed in compliance with the agreement.

[ARC 1351C, IAB 3/5/14, effective 4/9/14]

These rules are intended to implement Iowa Code sections 8.57(5) and 328.12.

[Filed 10/28/98, Notice 8/26/98—published 11/18/98, effective 12/23/98]

[Filed 12/17/03, Notice 11/12/03—published 1/7/04, effective 2/11/04]

[Filed ARC 1351C (Notice ARC 1270C, IAB 1/8/14), IAB 3/5/14, effective 4/9/14]

[Filed ARC 3880C (Notice ARC 3755C, IAB 4/25/18), IAB 7/4/18, effective 8/8/18]

CHAPTER 717  
GENERAL AVIATION VERTICAL INFRASTRUCTURE PROGRAM

**761—717.1(328) Purpose.** The purpose of the general aviation vertical infrastructure program is to provide funding for improvements to the vertical infrastructure at Iowa's general aviation airports.

[ARC 1351C, IAB 3/5/14, effective 4/9/14]

**761—717.2(328) Definitions.** The definitions in Iowa Code section 328.1 and rule 761—700.1(328) apply to these rules. In addition:

“*Vertical infrastructure*” means the same as defined in Iowa Code section 8.57(5).

[ARC 1351C, IAB 3/5/14, effective 4/9/14; ARC 3880C, IAB 7/4/18, effective 8/8/18]

**761—717.3(328) Information and forms.** Program information, instructions, and application forms may be obtained from the department's website at [www.iowadot.gov](http://www.iowadot.gov). Requests for such materials or assistance may also be made by calling the office of aviation at (515)239-1048. Submission of application materials shall be made according to the annual application instructions included in the application materials. The office of aviation mailing address is: Office of Aviation, Iowa Department of Transportation, 800 Lincoln Way, Ames, Iowa 50010.

[ARC 1351C, IAB 3/5/14, effective 4/9/14; ARC 3880C, IAB 7/4/18, effective 8/8/18]

**761—717.4(328) Applicant eligibility.** An airport sponsor, as defined in rule 761—700.1(328), of a publicly owned general aviation airport is eligible to apply for funding.

[ARC 1351C, IAB 3/5/14, effective 4/9/14]

**761—717.5(328) Eligible project activities.** Activities that are eligible for reimbursement include, but are not limited to, the following:

**717.5(1)** Hangar renovation or construction including associated design, land acquisition, grading and foundation work.

**717.5(2)** Fuel facilities including associated design, land acquisition, grading and foundation work.

**717.5(3)** Terminal building renovation or construction including associated design, land acquisition, grading and foundation work.

**717.5(4)** Relocating an existing hangar, terminal building or fuel facility to correct violations of federal safety or design standards. Work shall include all associated design, land acquisition, grading and foundation work.

**761—717.6(328) Ineligible project activities.** Rescinded IAB 11/14/01, effective 12/19/01.

**761—717.7(328) Funding.** The department establishes the maximum percentage of state share of eligible projects. The department may annually set a maximum dollar amount per award. Funding criteria are included in application instructions provided to airport sponsors.

[ARC 1351C, IAB 3/5/14, effective 4/9/14]

**761—717.8(328) Project priorities.** The department shall consider the following in project selection: airport role and objectives defined in the state aviation system plan; demonstration of increased aeronautical activity; justification for the project; local participation; and multijurisdictional support of the airport.

[ARC 1351C, IAB 3/5/14, effective 4/9/14]

**761—717.9(328) Project applications.**

**717.9(1)** The department shall make available application instructions and forms to each publicly owned airport in Iowa. Project applications shall be submitted to the department as directed in the annual application instructions.

**717.9(2)** Each application shall include the information and forms identified in the annual application instructions.

[ARC 1351C, IAB 3/5/14, effective 4/9/14]

**761—717.10(328) Review and approval.** Department staff shall review project applications and submit recommendations to the transportation commission. The commission is responsible for approving the projects to be funded.

**761—717.11(328) Project administration.**

**717.11(1) Agreement.** After a project has been approved by the commission, the department shall enter into an agreement with the airport sponsor that specifies the responsibilities of the sponsor. The agreement shall specify the amount of state funds, the contract period, the payment process, and the responsibilities for project planning, development, and reporting. The department may inspect the improvement for compliance with the agreement and may audit all project costs.

**717.11(2) Payments.** Payments to the airport sponsor for eligible project costs shall be made on a cost reimbursement basis. Engineering fees are an eligible project expense and shall be reimbursed in compliance with the agreement.

[ARC 1351C, IAB 3/5/14, effective 4/9/14]

These rules are intended to implement Iowa Code sections 8.57(5) and 328.12.

[Filed 1/20/00, Notice 12/15/99—published 2/9/00, effective 3/15/00]

[Filed 10/24/01, Notice 9/19/01—published 11/14/01, effective 12/19/01]

[Filed 12/14/05, Notice 11/9/05—published 1/4/06, effective 2/8/06]

[Filed ARC 1351C (Notice ARC 1270C, IAB 1/8/14), IAB 3/5/14, effective 4/9/14]

[Filed ARC 3880C (Notice ARC 3755C, IAB 4/25/18), IAB 7/4/18, effective 8/8/18]

CHAPTER 718  
GENERAL AVIATION HANGAR REVOLVING LOAN FUND  
Rescinded IAB 1/7/04, effective 2/11/04

CHAPTER 719  
Reserved



CHAPTER 720  
IOWA AIRPORT REGISTRATION  
[Prior to 6/3/87, Transportation Department [820]—(04,C)Ch 1]

**761—720.1(328) Scope.** This chapter establishes registration and registration renewal requirements and minimum safety standards for airports open for use by the public. It also establishes airport closing requirements.  
[ARC 6616C, IAB 11/2/22, effective 12/7/22]

**761—720.2(328) Definitions.** The definitions in Iowa Code section 328.1 and rule 761—700.1(328) shall apply to this chapter. In addition:

“*Obstruction*” means any structure, object of natural growth, or use of land that impedes the airspace required for the takeoff or landing of aircraft at an airport.

“*Private use*” means available for use by the owner or by the owner and other persons authorized by the owner.

“*Public use*” means available for use by the general public without prior approval from the owner or operator.

**761—720.3(328) Contact information.** Questions regarding this chapter may be directed to the Modal Transportation Bureau, Iowa Department of Transportation, 800 Lincoln Way, Ames, Iowa 50010; telephone (515)239-1468; or through the department’s website at [www.iowadot.gov](http://www.iowadot.gov).  
[ARC 6616C, IAB 11/2/22, effective 12/7/22]

**761—720.4(328) Public-use airport.** Airport registration requirements apply to public-use airports.

**720.4(1) Registration.** When construction of a new airport is completed, the sponsor shall notify the department. The department shall inspect the airport and, if the airport is in compliance with the minimum safety standards designated by the department, shall issue the airport a public-use airport certificate of registration.

**720.4(2) Registration renewal.** Each public-use airport shall apply annually for a registration renewal on a form provided by the department. The department shall issue a public-use airport certificate of registration to a public-use airport if the airport is in compliance with the minimum safety standards designated by the department.

**720.4(3) Airport inspection.** Each registered public-use airport is subject to inspection by the department at any reasonable time. If the inspection by the department reveals an unsafe condition or a failure to meet the minimum safety standards, the department shall record that fact and shall notify the airport sponsor in writing with necessary corrective actions. Failure to implement corrective actions may result in airport registration revocation or denial. An FAA inspection of an airport certified under 14 CFR Part 139 may be accepted in lieu of an inspection by the department.

**720.4(4) Posting.** The airport certificate of registration shall be posted in a prominent place available to the public at the airport. If there are no buildings at the airport, the certificate shall be displayed at the office of the airport manager or caretaker.

[ARC 3301C, IAB 8/30/17, effective 10/4/17; ARC 5943C, IAB 10/6/21, effective 11/10/21; ARC 6616C, IAB 11/2/22, effective 12/7/22]

**761—720.5(328) Private-use airport.** Rescinded ARC 6616C, IAB 11/2/22, effective 12/7/22.

**761—720.6(328) Revocation or denial.** The department may revoke or deny a certificate of registration or certificate of site approval pursuant to Iowa Code section 328.19.

**761—720.7 to 720.9** Reserved.

**761—720.10(328) Minimum safety standards.** The minimum safety standards for a public-use airport are as follows:

**720.10(1) Obstruction-free area.**

a. The following areas of the airport shall be free of any obstructions with the exception of operational and frangible equipment that is essential for operation of the airport:

(1) Within 30 feet of runway edge markers along the entire length of a nonpaved runway.

(2) Within 125 feet of the centerline of a paved runway.

(3) Within 200 feet of the end of any paved runway.

(4) In no case shall a building be closer than 50 feet from a prepared runway surface. If buildings are on both sides of a runway, they shall be no closer than 125 feet from the runway centerline.

b. An object of natural growth, terrain, or permanent or temporary construction within the areas listed in paragraph “a” of this subrule shall be removed by the sponsor.

c. The following areas of the airport shall be free of all agricultural activities (i.e., crops or farm equipment) in excess of 8 inches in height:

- (1) Within 50 feet of paved runway surfaces and 200 feet from paved runway ends.
- (2) Within 60 feet of a nonpaved runway centerline.
- (3) Within a 100-foot radius of automated weather observing system equipment.

**720.10(2) Runway.**

- a. *Width.* The minimum usable prepared runway width shall be 50 feet.
- b. *Marking.*

(1) Paved runways. Paved runways shall be marked in accordance with FAA Circular 150/5340-1M (Standards for Airport Markings) as amended through May 10, 2019.

(2) Nonpaved runways. Airport markers shall be approved by the modal transportation bureau. Markers shall be placed 200 feet apart outlining the length of the landing surface. Thresholds shall be marked using six markers placed perpendicular to the runway heading.

c. *Line of sight.* The runway sight distance shall provide an unobstructed line of sight from any point 5 feet above the runway surface to any other point 5 feet above the runway surface for the entire length of the runway; or the sponsor shall post in a conspicuous location a warning about the obstruction in the line of sight.

d. *Temporary warning.* Any part of the runway environment other than the runway which has become temporarily unsafe, or for any reason is not available for use, shall be marked by suitable flags, barriers or flares clearly showing the boundaries of the unsafe or unusable area.

- e. *Building location.* Rescinded IAB 7/4/07, effective 8/8/07.

**720.10(3) Approach zones.**

a. Approaches shall be clear of obstructions above a glide path of 20:1 from the ends of each usable runway. If an obstruction exists in an approach zone, the runway threshold on a paved runway shall be displaced in accordance with FAA Advisory Circular 150/5340-1M (Standards for Airport Markings) as amended through May 10, 2019. On a nonpaved runway, the runway end markers shall be relocated to provide the prescribed obstruction clearance. The runway length remaining between the displaced threshold and the departure end of the runway is the landing distance available.

b. When the approach zone to any runway crosses a road or railroad, the glide path on a 20:1 ratio shall pass at least 17 feet above an interstate highway, 15 feet above any other public roadway, 10 feet above a private road, and 23 feet above a railroad.

**720.10(4) Facilities.** The airport shall provide all of the following facilities:

a. *Wind indicator.* The airport shall be equipped with a wind sock, blaze orange in color, which shall be clearly visible from the traffic pattern altitude within one mile of the airport during daylight hours. If the airport is lighted for night operation, the wind sock shall also be lighted.

b. *Lighting.* If an airport is lighted for night operation, the system shall be lighted from dusk to dawn. An operable air-to-ground controller for the lighting system will meet this requirement.

- c. *Telephone.* A telephone shall be available for public use.

d. *Fire extinguisher.* At least one operational class B and class C fire extinguisher capable of extinguishing all classes of fires shall be readily accessible to aircraft fueling or ramp areas.

[ARC 3301C, IAB 8/30/17, effective 10/4/17; ARC 5943C, IAB 10/6/21, effective 11/10/21]

**761—720.11 to 720.14** Reserved.

**761—720.15(328) Airport closing.**

**720.15(1) Notice.** When an airport ceases operation for any reason, the sponsor shall notify the department, return the registration certificate and mark the landing area to clearly indicate that the airport is closed to air traffic.

**720.15(2) Marking.** All marking indicating a usable runway shall be obliterated. The sponsor shall place at a central location a yellow X in accordance with FAA Advisory Circular 150/5340-1M (Standards for Airport Markings) as amended through May 10, 2019.

**720.15(3) Temporary closing.** When conditions require the temporary closing of a runway, it shall be marked on both ends with a yellow X in accordance with FAA Advisory Circular 150/5340-1M (Standards for Airport Markings) as amended through May 10, 2019.

**720.15(4) Repayment of financial assistance.** Within 30 days of closing an airport (other than temporary closing), the sponsor shall request from the department a review of contractual obligations that require repayment of financial assistance. The department will provide a determination detailing grant obligations that must be repaid. Any repayment of grants must be made to the department in no more than five equal annual installments, beginning one

year from the airport's closure date. If an alternative future use of the airport facility is planned for a project that creates jobs and expands the economy, the sponsor may, within 30 days of the department's determination, request forgiveness of repayment. The request must include a plan detailing the alternative future use of the airport facility, an explanation of how the alternative future use creates jobs and expands the economy, a cost-benefit analysis from the sponsor, a commitment of private investment in the project equal to at least two times the amount of repayment due to the state, and a commitment from the sponsor, or associated political subdivision(s), to complete the alternative use project within five years. The department will review the request for forgiveness of repayment and approve or deny the request within 60 days of receipt.

[ARC 3301C, IAB 8/30/17, effective 10/4/17; ARC 5943C, IAB 10/6/21, effective 11/10/21]

These rules are intended to implement Iowa Code sections 328.1, 328.12, 328.19 as amended by 2022 Iowa Acts, House File 2124, and 328.35 and 2016 Iowa Acts, chapter 1131, section 3.

[Filed 8/3/76, Notice 6/14/76—published 8/23/76, effective 9/27/76]

[Filed 5/11/87, Notice 3/11/87—published 6/3/87, effective 7/8/87]

[Filed 9/2/87, Notice 7/15/87—published 9/23/87, effective 10/28/87]

[Filed 12/5/90, Notice 10/3/90—published 12/26/90, effective 1/30/91]

[Filed 1/15/92, Notice 12/11/91—published 2/5/92, effective 3/11/92]

[Filed 12/16/93, Notice 11/10/93—published 1/5/94, effective 2/9/94]

[Filed 12/17/03, Notice 11/12/03—published 1/7/04, effective 2/11/04]

[Filed 6/14/07, Notice 4/25/07—published 7/4/07, effective 8/8/07]

[Filed ARC 3301C (Notice ARC 3128C, IAB 6/21/17), IAB 8/30/17, effective 10/4/17]

[Filed ARC 5943C (Notice ARC 5805C, IAB 7/28/21), IAB 10/6/21, effective 11/10/21]

[Filed ARC 6616C (Notice ARC 6477C, IAB 8/24/22), IAB 11/2/22, effective 12/7/22]



CHAPTERS 721 to 749  
Reserved



CHAPTER 750  
AIRCRAFT REGISTRATION

[Prior to 6/3/87, Transportation Department [820]—(04,C)Ch 2]

**761—750.1(328) Purpose.** This chapter establishes the procedures for registration of civil aircraft pursuant to Iowa Code chapter 328.

This rule is intended to implement Iowa Code chapter 328.

[ARC 5943C, IAB 10/6/21, effective 11/10/21]

**761—750.2(328) Definitions.** The definitions in Iowa Code section 328.1 apply to this chapter of rules. In addition, the following definition is established for the purpose of Iowa Code section 328.21(8) and subrule 750.10(3):

“*Specified minimum level of aviation services to the general public*” means the use of aircraft that provide nonagricultural aviation services including aircraft rental, flight training, or passenger and cargo air carrier operations.

This rule is intended to implement Iowa Code sections 328.1 and 328.21(8).

[ARC 5943C, IAB 10/6/21, effective 11/10/21]

**761—750.3(17A) Information and forms.** Information, instructions and forms are available from the modal transportation bureau or on the department’s website at [www.iowadot.gov](http://www.iowadot.gov). Application forms may also be obtained from aircraft dealers. The mailing address for aircraft registration is: Iowa Department of Transportation, Modal Transportation Bureau, Aircraft Registration, 800 Lincoln Way, Ames, Iowa 50010.

This rule is intended to implement Iowa Code section 17A.3.

[ARC 3301C, IAB 8/30/17, effective 10/4/17; ARC 5943C, IAB 10/6/21, effective 11/10/21]

**761—750.4 to 750.8** Reserved.

**761—750.9(328) Registration.** When a used aircraft is registered in Iowa, the model year of the aircraft shall be used to determine the number of times the aircraft was previously registered, and a reduction of the registration fee shall be computed accordingly. “Model year,” except where otherwise specified, means the year of original manufacture or the year certified by the manufacturer. For the purpose of registration, the model year shall advance one year each January 1.

This rule is intended to implement Iowa Code section 328.21.

**761—750.10(328) First registration procedure.**

**750.10(1) Registration requirement.** A civil aircraft which has an FAA-assigned N number is subject to registration in Iowa unless it is exempt by statute.

**750.10(2) Application.**

a. The owner of an unregistered aircraft shall submit to the department an application for aircraft registration on a form prescribed by the department.

b. The owner shall submit with the application the registration fee and the required use tax or evidence of tax exemption.

c. The department shall review the application and may request additional information or documents from the owner.

d. Upon receipt of the completed application, registration fee, and use tax or evidence of tax exemption, the department shall issue to the applicant an aircraft registration certificate for the aircraft.

**750.10(3) Fee.** The aircraft registration fee shall be computed according to Iowa Code section 328.21.

This rule is intended to implement Iowa Code sections 328.20, 328.21, 328.25 to 328.27, 328.35, 328.37, 328.42, 328.44 to 328.46 and 328.56A.

**761—750.11 to 750.14** Reserved.

**761—750.15(328) Aircraft not airworthy.** An aircraft that is not airworthy is not subject to registration fees if the owner submits with the registration application a written, signed explanation of the aircraft’s condition and an estimate of the date when the aircraft will be airworthy. The department shall mark the record of the aircraft until the owner notifies the department that the aircraft is airworthy or until the aircraft is no longer subject to registration in Iowa.

This rule is intended to implement Iowa Code section 328.21.

[ARC 3301C, IAB 8/30/17, effective 10/4/17]

**761—750.16 to 750.19** Reserved.

**761—750.20(328) Renewal notice.** Thirty days before the end of the registration year, the department shall send a renewal notice to the owner of each registered aircraft as shown on department records. The renewal notice shall state the registration fee due for the upcoming registration year and the descriptive data recorded for the aircraft.

This rule is intended to implement Iowa Code sections 328.20, 328.21, 328.26, 328.27, 328.37, and 328.56A.

**761—750.21 to 750.28** Reserved.

**761—750.29(328) Penalty on registration fees.**

**750.29(1) Amount of penalty.** The penalty on the delinquent payment of a registration fee shall be computed on a monthly basis and is 5 percent per month.

**750.29(2) Aircraft purchased.** The penalty on the registration fee shall accrue from the first day of the month following 30 days from the date of purchase.

**750.29(3) Aircraft moved into Iowa.** The penalty on the registration fee shall accrue from the first day of the month following 30 days from the date the aircraft is moved into Iowa.

**750.29(4) When delinquency extends beyond the current year.** When the penalty on a delinquent registration fee extends beyond the current year, the penalty shall continue to accrue until paid. The penalty shall accrue only on the fee applicable at the time the delinquency accrued and shall not be applicable to subsequent registration fees which have not been paid.

**750.29(5) Specific penalty date.** When a specific penalty date is provided by statute or rule, the penalty shall accrue from that date, even if the day is a Saturday, Sunday or holiday.

This rule is intended to implement Iowa Code sections 328.50 to 328.52.

**761—750.30(328) Application for special certificate.** When applying to the department for a special certificate, the applicant must submit reasonable proof of bona fide status as a manufacturer, transporter or dealer. Manufacturer or dealer applicants must verify that no aircraft have been held in a dealer special certificate inventory for a period of more than three years.

This rule is intended to implement Iowa Code section 328.28 as amended by 2022 Iowa Acts, Senate File 2370, section 1, and section 328.29.

[ARC 5943C, IAB 10/6/21, effective 11/10/21; ARC 6616C, IAB 11/2/22, effective 12/7/22]

**761—750.31(328) Lien.** The department has the authority to record a lien against the federal aircraft title and sue to collect unpaid fees and penalties.

This rule is intended to implement Iowa Code sections 328.47 to 328.49.

[ARC 5943C, IAB 10/6/21, effective 11/10/21]

[Filed 7/1/75]

[Filed 8/3/76, Notice 6/14/76—published 8/23/76, effective 9/27/76]

[Filed 5/11/87, Notice 3/11/87—published 6/3/87, effective 7/8/87]

[Filed 7/27/88, Notice 6/15/88—published 8/24/88, effective 9/28/88]

[Filed 1/15/92, Notice 12/11/91—published 2/5/92, effective 3/11/92]

[Filed 12/26/96, Notice 11/20/96—published 1/15/97, effective 2/19/97]

[Filed 3/10/99, Notice 1/13/99—published 4/7/99, effective 5/12/99]

[Filed 11/2/05, Notice 9/14/05—published 11/23/05, effective 12/28/05]

[Filed 10/11/06, Notice 8/30/06—published 11/8/06, effective 12/13/06]

[Filed ARC 3301C (Notice ARC 3128C, IAB 6/21/17), IAB 8/30/17, effective 10/4/17]

[Filed ARC 5943C (Notice ARC 5805C, IAB 7/28/21), IAB 10/6/21, effective 11/10/21]

[Filed ARC 6616C (Notice ARC 6477C, IAB 8/24/22), IAB 11/2/22, effective 12/7/22]

CHAPTERS 751 to 799  
Reserved



## RAILROADS

## CHAPTER 800

## ITEMS OF GENERAL APPLICATION FOR RAILROADS

[Prior to 6/3/87, Transportation Department [820]—(10,A)Ch 1]

**761—800.1(307) Definitions.** The following terms when used in this division of rules shall have the following meanings:

“*Crossing*” means the point where the railroad tracks and highway meet at the same location.

“*Department*” means the state department of transportation.

“*Railroad*” means persons who own rail facilities or who are responsible for their operation and maintenance.

This rule is intended to implement Iowa Code sections 307.1 and 307.26.

[ARC 6709C, IAB 11/30/22, effective 1/4/23]

**761—800.2(17A) Location and submission of documents.** All documents concerning railroad matters which, according to statute or rule, must be submitted to the department shall be submitted to the following address: Modal Transportation Bureau, Iowa Department of Transportation, 800 Lincoln Way, Ames, Iowa 50010.

This rule is intended to implement Iowa Code section 17A.3.

[ARC 6709C, IAB 11/30/22, effective 1/4/23]

**761—800.3(327C) Accounts.** All railroads operating in Iowa, except those whose accounts are regulated by the Surface Transportation Board, shall maintain accounts using the generally accepted accounting principles of the financial standards accounting board. The accrual method of accounting shall be used.

This rule is intended to implement Iowa Code section 327C.42.

**761—800.4(327C) Annual reports.**

**800.4(1)** A railroad company submitting an annual report to the Surface Transportation Board under 49 CFR Part 1241 shall submit a copy of this report to the department on or before April 1 following the close of the calendar year. Included with this report shall be a “State Statistics” report, which shall include the following: annual data on additions and deletions of mileage within the state; mileage operated within the state at the end of the year; railway operating revenues earned within the state; statistics on rail line operations within the state, including locomotive unit-miles, car-miles and ton-miles; revenue freight carried within the state by commodity class; and a freight density map showing gross ton-miles for the railroad company’s system within the state.

For the purpose of this rule, 49 CFR Part 1241 is adopted as of October 1, 2023.

**800.4(2)** A railroad company not required to submit an annual report to the Surface Transportation Board under 49 CFR Part 1241 shall submit an annual report to the department electronically on or before April 1 following the close of the calendar year.

This rule is intended to implement Iowa Code sections 327C.38 and 327C.41.

[ARC 3881C, IAB 7/4/18, effective 8/8/18; ARC 6709C, IAB 11/30/22, effective 1/4/23; ARC 8055C, IAB 6/12/24, effective 7/17/24]

**761—800.5 to 800.14** Reserved.

**761—800.15(327F) Train speed ordinances.** An ordinance or resolution adopted by a political subdivision which relates to the speed of a train in an area within the jurisdiction of the political subdivision is subject to department approval according to the following procedure:

**800.15(1)** The political subdivision shall submit the ordinance/resolution to the department supported by information or reasons that justify its approval by the department.

**800.15(2)** The department shall notify the affected railroads.

**800.15(3)** The political subdivision and the affected railroads shall have 30 days in which to submit position papers to the department before the department issues an order approving or disapproving the ordinance/resolution.

**800.15(4)** The department shall issue an order approving or disapproving the ordinance/resolution in accordance with the following:

*a.* The department may approve the proposed ordinance/resolution only if the proposal satisfies the requirements of 49 U.S.C. 20106 as amended to August 3, 2007: (1) it is necessary to eliminate or reduce an essentially local safety or security hazard; (2) it is not incompatible with a federal law, regulation or order of the United States government; and (3) it does not unreasonably burden interstate commerce.

*b.* Generally, the department does not consider highway-railroad grade crossings or rail lines located near schools, residences, or commercial activities to be local safety hazards that can be remedied by train speed restrictions.

c. In making its decision, the department may also consider the following factors:

- (1) Traffic density and speed.
- (2) Accident frequency.
- (3) Causes of accidents.
- (4) Obstructions to visibility.
- (5) Traffic controls at crossings.
- (6) Population density.
- (7) Resulting burden on the rail transportation system.
- (8) Resulting benefit to residents of the political subdivision.

**800.15(5)** The department shall mail notice of its order approving or disapproving the ordinance/resolution by certified mail, return receipt requested, to the political subdivision and the affected railroads.

**800.15(6)** If the department issues an order approving the ordinance/resolution, it shall go into effect 25 days after the notice is mailed unless the order is contested pursuant to subrule 800.15(7).

**800.15(7)** Within 20 days after the notice is mailed, the political subdivision or an affected railroad may submit to the department a written statement contesting the department's order approving or disapproving the ordinance/resolution.

a. If the order is contested, 761—Chapter 13 applies.

b. If an order approving an ordinance/resolution is contested, the order shall be stayed pending the outcome of the contested case.

**800.15(8)** A submission to the department under this rule shall be deemed timely submitted if it is delivered or postmarked within the time period specified.

This rule is intended to implement Iowa Code section 327F.31 and 2001 Iowa Op. Att'y Gen. #01-5-2.

[ARC 6709C, IAB 11/30/22, effective 1/4/23; ARC 8055C, IAB 6/12/24, effective 7/17/24]

**761—800.16 to 800.19** Reserved.

#### **761—800.20(327G) Removal of tracks from crossings.**

**800.20(1)** 49 CFR Part 1152 contains the regulations governing the abandonment and discontinuance of railroad lines and rail transportation under 49 U.S.C. 10903 et seq. This part also contains the regulations and procedures for the acquisition or use of railroad rights-of-way proposed for abandonment for interim trail use and rail banking pursuant to 16 U.S.C. 1247(d).

For the purpose of this rule, 49 CFR Part 1152 is adopted as of October 1, 2023.

**800.20(2)** A railroad corporation or its successor in interest having received authority to remove its tracks from a rail line pursuant to abandonment or interim trail use under 49 CFR Part 1152 shall, at the same time it removes its tracks from the railroad rights-of-way, remove its tracks from the crossings of highways, streets and alleys along the rail line and restore the surface of these crossings. A crossing shall be restored in a manner specified by the agency having jurisdiction over the highway, street or alley at the crossing.

**800.20(3)** If a railroad corporation or its successor in interest fails to remove its tracks from and restore the surface of a crossing as specified in subrule 800.20(2), then the agency having jurisdiction over the highway, street or alley at the crossing may, at the expense of the railroad corporation or its successor in interest, remove the tracks and restore the surface 120 days after the tracks adjacent to the crossing have been removed.

This rule is intended to implement Iowa Code section 327G.24.

[ARC 3881C, IAB 7/4/18, effective 8/8/18; ARC 6709C, IAB 11/30/22, effective 1/4/23; ARC 8055C, IAB 6/12/24, effective 7/17/24]

**761—800.21(327G) Federal citations.** Copies of the federal code or regulations cited in this chapter are available from the state law library or online at [www.gpo.gov](http://www.gpo.gov).

This rule is intended to implement Iowa Code section 327G.24.

[ARC 3881C, IAB 7/4/18, effective 8/8/18]

[Filed 8/24/82, Notice 7/7/82—published 9/15/82, effective 10/20/82]

[Filed 10/2/85, Notice 8/14/85—published 10/23/85, effective 11/27/85]

[Filed 5/11/87, Notice 3/11/87—published 6/3/87, effective 7/8/87]

[Filed 5/19/89, Notice 3/8/89—published 6/14/89, effective 7/19/89]

[Filed 8/8/90, Notice 6/27/90—published 9/5/90, effective 10/10/90]

[Filed 7/15/03, Notice 5/14/03—published 8/6/03, effective 9/10/03]

[Filed ARC 3881C (Notice ARC 3756C, IAB 4/25/18), IAB 7/4/18, effective 8/8/18]

[Filed ARC 6709C (Notice ARC 6574C, IAB 10/5/22), IAB 11/30/22, effective 1/4/23]

[Filed ARC 8055C (Notice ARC 7745C, IAB 4/3/24), IAB 6/12/24, effective 7/17/24]



CHAPTER 801  
RELATIONSHIP WITH IOWA RAILWAY FINANCE AUTHORITY  
[Prior to 6/3/87, Transportation Department[820]—(10,C)Ch 2]  
Rescinded IAB 7/1/09, effective 7/1/09



CHAPTER 802  
NOTIFICATION OF RAILROAD ACCIDENTS/INCIDENTS  
[Prior to 6/3/87, Transportation Department [820]—(10,B)Ch 6]

**761—802.1(327C) Written reports.**

**802.1(1)** *When required.* A railroad filing with the Federal Railroad Administration any of the forms listed in subrule 802.1(2) shall, at the same time, file a copy with the department at the following address if the accident or incident occurred in Iowa: Modal Transportation Bureau, Iowa Department of Transportation, 800 Lincoln Way, Ames, Iowa 50010.

**802.1(2)** *Forms.* This rule applies to the following Federal Railroad Administration forms:

FRA F 6180.54 — Rail Equipment Accident/Incident Report

FRA F 6180.57 — Rail-Highway Grade Crossing Accident/Incident Report

This rule is intended to implement Iowa Code section 327C.41.

[ARC 3882C, IAB 7/4/18, effective 8/8/18; Editorial change: IAC Supplement 8/24/22]

**761—802.2(327C) Notification of railroad accidents/incidents.**

**802.2(1)** *Accidents or incidents requiring notification.* Any accident/incident involving train movement which results in any of the following shall be reported within four hours of the accident/incident to the department:

- a. Fatality.
- b. Personal injury requiring hospitalization.
- c. Derailment of ten or more rail cars and locomotives.
- d. Derailment of any number of cars or locomotives when one or more are not upright.
- e. Derailment or other incident involving a railroad passenger train.
- f. Release or potential release of hazardous materials that presents a risk or potential risk to public safety including injury, fatality, evacuation or shelter-in-place of persons.
- g. Damage to public or private transportation infrastructure not owned by the involved railroad.

**802.2(2)** *Content of notice.* The notice of an accident/incident shall provide, at a minimum, the following information:

- a. Name of the railroad involved.
- b. Name and contact information of the individual calling to file the notice.
- c. Date and time the accident/incident occurred.
- d. Location of the accident/incident, described as accurately as possible, including the nearest city and the U.S. DOT crossing identification number or railroad milepost.
- e. Description of the accident/incident.
- f. Impact on motor vehicle travel, if known.
- g. Number of injuries and fatalities.
- h. Hazardous materials involved in the incident and actions taken in the event of a release.
- i. Number of rail cars derailed.

**802.2(3)** *Method of notification.* The notice shall be made to the department's traffic management center by telephone at (515)237-3300 (open year-round, 24 hours a day, including legal holidays).

This rule is intended to implement Iowa Code sections 327C.37 and 327C.41.

[ARC 3882C, IAB 7/4/18, effective 8/8/18]

[Filed 8/24/82, Notice 7/7/82—published 9/15/82, effective 10/20/82]

[Filed 10/2/85, Notice 8/14/85—published 10/23/85, effective 11/27/85]

[Filed 5/11/87, Notice 3/11/87—published 6/3/87, effective 7/8/87]

[Filed 8/26/88, Notice 7/13/88—published 9/21/88, effective 10/26/88]

[Filed 1/10/90, Notice 11/29/89—published 2/7/90, effective 3/14/90]

[Filed 1/15/92, Notice 12/11/91—published 2/5/92, effective 3/11/92]

[Filed 7/15/03, Notice 5/14/03—published 8/6/03, effective 9/10/03]

[Filed ARC 3882C (Notice ARC 3757C, IAB 4/25/18), IAB 7/4/18, effective 8/8/18]

[Editorial change: IAC Supplement 8/24/22]



CHAPTERS 803 to 809  
Reserved



CHAPTER 810  
RAILROAD SAFETY STANDARDS  
[Prior to 6/3/87, Transportation Department [820]—(10,B)Ch 1]

**761—810.1(327C) Track safety standards.**

**810.1(1) Standards.** The department adopts the railroad track safety standards contained in 49 CFR Part 213 (October 1, 2023).

**810.1(2) Obtaining copies of regulations.** Copies of the federal regulations are available from the state law library or online at [www.gpo.gov](http://www.gpo.gov).

This rule is intended to implement Iowa Code sections 307.26 and 327C.4.

[ARC 3881C, IAB 7/4/18, effective 8/8/18; ARC 6709C, IAB 11/30/22, effective 1/4/23; ARC 8055C, IAB 6/12/24, effective 7/17/24]

**761—810.2(327C) Track inspection.**

**810.2(1) Credentials required.** Authorized departmental employees shall be admitted to any railroad property to conduct safety inspections of the track and track structures and shall present state identification cards upon request.

**810.2(2) Measurement tools and vehicles.** Rescinded IAB 8/6/03, effective 9/10/03.

This rule is intended to implement Iowa Code section 327C.4.

**761—810.3** Reserved.

**761—810.4(327F) First aid and medical treatment for railroad employees.**

**810.4(1)** Railroad employees who are injured in the course of employment shall have reasonable and adequate access to first aid or medical treatment. A railroad or railroad employee shall not:

*a.* Deny, delay or interfere with first aid or medical treatment for any railroad employee who is injured in the course of employment.

*b.* Discipline or threaten to discipline any railroad employee for requesting first aid or medical treatment when the employee is injured in the course of employment.

**810.4(2)** All railroads operating in the state must make reasonable efforts to have emergency first-aid kits available at locations where railroad employees perform their employment duties.

**810.4(3)** Nothing in this rule shall be construed to require a railroad or railroad employee to perform first aid or medical care.

This rule is intended to implement Iowa Code section 327F.38.

**761—810.5(327F) Worker transportation motor vehicle equipment.**

**810.5(1) Heater requirement.** Pursuant to Iowa Code subsection 327F.39(4), a motor vehicle used to transport railroad workers shall be equipped with a heating system that maintains a reasonable comfort level in the vehicle spaces where the workers are required to ride. The heating system shall comply with the safety standards established in 49 CFR 393.77, as adopted in rule 661—22.1(321).

**810.5(2) Report procedure.**

*a.* A person shall report an alleged violation in writing to the responsible railroad company at its corporate headquarters.

*b.* If within 30 days the railroad company does not respond or if the response is unsatisfactory, the person may report the alleged violation to the department at the following address: Modal Transportation Bureau, Iowa Department of Transportation, 800 Lincoln Way, Ames, Iowa 50010.

*c.* The report shall include the date, time, weather conditions and all facts pertinent to the alleged violation. The report shall also include a copy of the railroad's response or, if the railroad failed to respond, proof of the date the report was submitted to the railroad.

*d.* The director of the modal transportation bureau or the director's designee may request additional information from the person submitting the report, the railroad worker transportation company or the railroad.

*e.* The director of the modal transportation bureau or the director's designee, which may include peace officers within the commercial motor vehicle unit of the department of public safety, may investigate the alleged violation.

*f.* The director of the modal transportation bureau or the director's designee shall issue a decision within 20 days of receipt of the report or 20 days after receipt of the requested additional information. The decision may include any order as necessary to enforce the requirements of Iowa Code section 327F.39, as set forth in Iowa Code section 327F.39(6).

*g.* The department shall notify the person and the railroad of the decision.

*h.* The decision is final agency action.

This rule is intended to implement Iowa Code section 327F.39.

[ARC 3881C, IAB 7/4/18, effective 8/8/18; ARC 6709C, IAB 11/30/22, effective 1/4/23; Editorial change: IAC Supplement 7/26/23]

**761—810.6(327F) Worker transportation rest periods.**

**810.6(1) Requirements.** A railroad worker transportation company and railroad worker transportation company driver shall comply with the rest period requirements of Iowa Code sections 321.449A and 327F.39(5).

**810.6(2) Report procedure.**

*a.* A person shall report an alleged violation in writing to the department at the following address: Modal Transportation Bureau, Iowa Department of Transportation, 800 Lincoln Way, Ames, Iowa 50010.

*b.* The report shall include the date, time, circumstances and any evidence of an alleged violation, and the name and contact information of the driver employed by the railroad worker transportation company or the railroad worker transportation company alleged to require a driver to violate the provisions of Iowa Code section 321.449A or 327F.39(5).

*c.* The director of the modal transportation bureau or the director's designee may request additional information from the driver, railroad worker transportation company or railroad.

*d.* The director of the modal transportation bureau or the director's designee, which may include peace officers within the commercial motor vehicle unit of the department of public safety, may investigate the alleged violation.

*e.* The director of the modal transportation bureau or the director's designee shall issue a decision within 60 days of receipt of the report or 60 days after receipt of the requested additional information. The decision may include any order as necessary to enforce the requirements of Iowa Code section 327F.39, as set forth in Iowa Code section 327F.39(6).

*f.* The department shall notify the driver and the railroad worker transportation company of the decision.

*g.* The decision is final agency action.

This rule is intended to implement Iowa Code sections 321.449A and 327F.39.

[ARC 3881C, IAB 7/4/18, effective 8/8/18; ARC 6709C, IAB 11/30/22, effective 1/4/23; Editorial change: IAC Supplement 7/26/23]

[Filed 8/24/82, Notice 7/7/82—published 9/15/82, effective 10/20/82]

[Filed 10/2/85, Notice 8/14/85—published 10/23/85, effective 11/27/85]

[Filed 5/11/87, Notice 3/11/87—published 6/3/87, effective 7/8/87]

[Filed 8/26/88, Notice 7/13/88—published 9/21/88, effective 10/26/88]

[Filed 1/10/90, Notice 11/29/89—published 2/7/90, effective 3/14/90]

[Filed 7/15/03, Notice 5/14/03—published 8/6/03, effective 9/10/03]

[Filed 5/11/05, Notice 3/16/05—published 6/8/05, effective 7/13/05]

[Filed ARC 3881C (Notice ARC 3756C, IAB 4/25/18), IAB 7/4/18, effective 8/8/18]

[Filed ARC 6709C (Notice ARC 6574C, IAB 10/5/22), IAB 11/30/22, effective 1/4/23]

[Editorial change: IAC Supplement 7/26/23]

[Filed ARC 8055C (Notice ARC 7745C, IAB 4/3/24), IAB 6/12/24, effective 7/17/24]

CHAPTER 811  
HIGHWAY-RAILROAD GRADE CROSSING WARNING DEVICES

[Prior to 6/3/87, Transportation Department [820]—(10,B)Ch 2]

**761—811.1(307) Standards.** All highway-railroad grade crossing warning devices installed shall conform to Part 8, “Traffic Controls for Railroad and Light Rail Transit Grade Crossings,” of the “Manual on Uniform Traffic Control Devices” as adopted in 761—Chapter 130.

This rule is intended to implement Iowa Code sections 307.26(7) “b,” 321.252 and 327G.2.

[ARC 6710C, IAB 11/30/22, effective 1/4/23]

**761—811.2(307) Contact information.** Information about this chapter may be obtained by contacting the department at the following address: Modal Transportation Bureau, Iowa Department of Transportation, 800 Lincoln Way, Ames, Iowa 50010; telephone (515)239-1108.

This rule is intended to implement Iowa Code section 307.26.

[ARC 6710C, IAB 11/30/22, effective 1/4/23]

[Filed 8/24/82, Notice 7/7/82—published 9/15/82, effective 10/20/82]

[Filed 10/2/85, Notice 8/14/85—published 10/23/85, effective 11/27/85]

[Filed 5/11/87, Notice 3/11/87—published 6/3/87, effective 7/8/87]

[Filed 4/17/96, Notice 3/13/96—published 5/8/96, effective 6/12/96]

[Filed 7/15/03, Notice 5/14/03—published 8/6/03, effective 9/10/03]

[Filed ARC 6710C (Notice ARC 6575C, IAB 10/5/22), IAB 11/30/22, effective 1/4/23]



CHAPTER 812  
CLASSIFICATIONS AND STANDARDS FOR  
HIGHWAY-RAILROAD GRADE CROSSINGS

[Substance formerly in (06,A)Ch 1]  
[Prior to 6/3/87, Transportation Department [820]—(10,B)Ch 3]

**761—812.1(307) Purpose and contact information.**

**812.1(1)** This chapter implements Iowa Code section 307.26(7)“b.” This statute requires the department to classify highway-railroad grade crossings based upon their characteristics, conditions and hazards and to adopt standards for warning devices for each classification.

**812.1(2)** Information about this chapter may be obtained by contacting the department at the following address: Modal Transportation Bureau, Iowa Department of Transportation, 800 Lincoln Way, Ames, Iowa 50010; telephone (515)239-1108.

[ARC 6710C, IAB 11/30/22, effective 1/4/23]

**761—812.2(307) Classification.** Crossings shall be classified using the Federal Railroad Administration’s predicted accident methodology.

**812.2(1)** The following formula is used to calculate an initial accident prediction for a crossing:

$$a = K \times EI \times DT \times MS \times MT \times HP \times HL$$

where:

a = initial accident prediction, in accidents per year at the crossing

K = formula constant

EI = factor for exposure index based on product of highway and train traffic

DT = factor for number of through trains per day during daylight

MS = factor for maximum timetable speed

MT = factor for number of main tracks

HP = factor for highway paved (yes or no)

HL = factor for number of highway lanes

**812.2(2)** A final predicted accident rate is then calculated from the initial prediction using the most recent five years of accident data for that crossing.

**812.2(3)** On or before October 1 of each year, the department shall furnish to each highway authority and railroad in Iowa a list of its crossings ranked by final predicted accident rate.

**761—812.3(307) Warning device standards and their implementation.**

**812.3(1)** A crossing with a final predicted accident rate of .075 or above is a candidate for upgrading. The following are recommended minimum improvements, subject to the considerations set out in the remainder of this rule.

| <u>Number<br/>Tracks</u> | <u>Current<br/>Installation</u> | <u>Proposed<br/>Upgrade To</u>               |
|--------------------------|---------------------------------|--|
| 1                        | Crossbucks                      | Flashers                                     |
| 1                        | Flashers                        | Gate Arms                                    |
| 2 or more                | Crossbucks                      | Gate Arms                                    |
| 2 or more                | Flashers                        | Gate Arms                                    |
| 2 or more                | Gate Arms                       | 4 Quadrant Gate Arms<br>or<br>Raised Medians |

**812.3(2)** The highway authority (governmental unit(s) having jurisdiction of the highway or street at the crossing) and the railroad shall jointly conduct a field review of a crossing they propose to upgrade.

*a.* Variations of warning devices or warning device circuitry including, but not limited to, prediction circuitry, motion sensor circuitry and cantilever assemblies shall be determined by conditions at the crossing site.

*b.* Site conditions shall determine whether safety improvements to correct these conditions should be made in lieu of the upgrades listed in subrule 812.3(1). Safety improvements are generally recommended if they would be less expensive than the upgrades and would result in a final predicted accident rate lower than .075. Safety improvements to consider include, but are not limited to, luminaires, pavement markings, sight distance improvement, signing modifications, rail signal/traffic signal interconnections, surveillance systems and crossing surface extensions.

**812.3(3)** The highway authority shall consider crossing consolidation or closure in lieu of upgrading the warning devices at a crossing. A grade separation may also be considered, but the decision to construct a separation is based on factors beyond the scope of this chapter.

**812.3(4)** When planning a highway improvement project encompassing or adjacent to a crossing, the highway authority shall consider the safety impacts that the project may have on the crossing.

**812.3(5)** An agreement between the highway authority and the railroad is required for warning device installations at a new crossing location and warning device upgrades on a detour.

[ARC 6710C, IAB 11/30/22, effective 1/4/23]

**761—812.4(307) Effect of rules.**

**812.4(1)** In accordance with Iowa Code section 307.26(7) “b,” the department of transportation is not liable for the development or adoption of the classifications or standards. A government agency, department or political subdivision is not liable for failure to implement the standards.

**812.4(2)** Nothing in this chapter shall preclude a highway authority and railroad from upgrading the warning devices at any crossing under their jurisdiction.

[ARC 6710C, IAB 11/30/22, effective 1/4/23]

These rules are intended to implement Iowa Code section 307.26(7) “b.”

[Filed 8/24/82, Notice 7/7/82—published 9/15/82, effective 10/20/82]

[Filed 5/11/87, Notice 3/11/87—published 6/3/87, effective 7/8/87]

[Filed 1/10/90, Notice 11/29/89—published 2/7/90, effective 3/14/90]

[Filed 4/17/96, Notice 3/13/96—published 5/8/96, effective 6/12/96]

[Filed ARC 6710C (Notice ARC 6575C, IAB 10/5/22), IAB 11/30/22, effective 1/4/23]

CHAPTER 813  
CLOSE-CLEARANCE WARNING SIGNS ALONG RAILROAD TRACKS

**761—813.1(327F) Purpose and scope.** This chapter implements Iowa Code section 327F.13. This statute requires the Iowa department of transportation (department) to implement the placement of close-clearance warning signs along railroad tracks where the close clearance between the tracks and an obstruction physically impedes a person who is lawfully riding the side of a train from clearing the obstruction. This chapter only applies when funds are available from the department to reimburse the owner for the cost of the close-clearance warning sign and installation.

[ARC 8202B, IAB 10/7/09, effective 11/11/09]

**761—813.2(327F) Applicability.** This chapter applies to railroad companies as well as industries, agricultural cooperatives or other entities that are owners of a railroad track, and it applies to individuals who are owners of a railroad track. This chapter does not apply to any railroad locations where locomotives are powered by overhead or suspended electric power.

[ARC 8202B, IAB 10/7/09, effective 11/11/09]

**761—813.3(327F) Information.** Information regarding this chapter is available from the Office of Rail Transportation, Iowa Department of Transportation, 800 Lincoln Way, Ames, Iowa 50010; telephone (515)239-1140.

[ARC 8202B, IAB 10/7/09, effective 11/11/09]

**761—813.4(327F) Definitions.**

“*Close clearance*” means a permanent or temporary situation where an obstruction near a railroad track physically impedes a person who is lawfully riding the side of a train from clearing the obstruction. Rule 761—813.5(327F) provides further detail on the dimensions that identify a close-clearance situation.

“*Obstruction*” means a building, machinery (other than equipment designed for operation on a railroad track when actually located on a railroad track), tree, brush or other object.

“*Owner*” means the railroad company, industry, agricultural cooperative, other entity, or individual that holds a fee simple title, easement, leasehold, contract to purchase, license, or other legal or equitable interest or right in the railroad track, and is in primary possession and control of the railroad track.

“*Tangent track*” means a track segment without any curves.

[ARC 8202B, IAB 10/7/09, effective 11/11/09]

**761—813.5(327F) Close-clearance dimensions.**

**813.5(1)** Close clearance for tangent track is a location along the railroad track where there is an obstruction that falls within the following dimensions: starting at the centerline of track at top of rail and extending 5 feet both sides horizontally and level therewith, thence upward vertically 15 inches, thence upward diagonally to a point 4 feet above top of rail and 8 feet laterally from centerline of track, thence vertically to a point 20 feet above top of rail, thence diagonally to a point 6 feet from centerline of track and 22 feet above top of rail, thence horizontally to centerline of track. Vertical clearance shall be 18 feet above top of rail at the entrance to and inside buildings. On curved track, clearances on each side of the track centerline shall be increased 1½ inches per degree of curvature. (See Figure 1.)

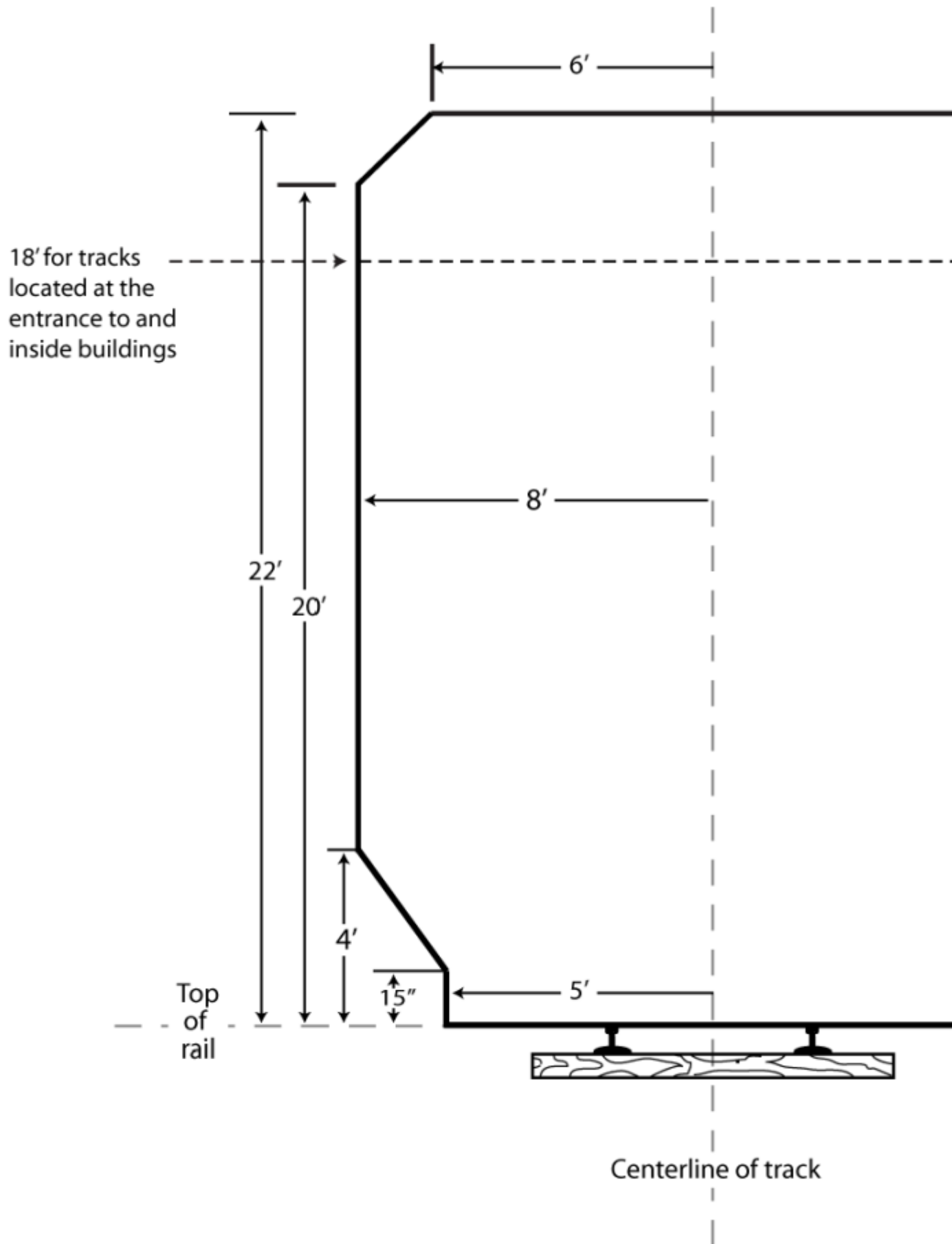

Figure 1

**813.5(2)** Reserved.

[ARC 8202B, IAB 10/7/09, effective 11/11/09]

**761—813.6(327F) Signing requirements.**

**813.6(1)** A close-clearance warning sign or signs are required at all locations where there is close clearance. It is the responsibility of the owner to ensure that all close-clearance locations have warning signs.

**813.6(2)** If an obstruction creating a close-clearance situation is a temporary or nonpermanent obstruction, in lieu of signing the owner may meet the requirements of this rule by opting to remove the obstruction or remove the track from service until the obstruction is removed.

**813.6(3)** A close-clearance warning sign shall be placed in a location that provides adequate notice to a person who is lawfully riding the side of a train so that the person may prepare for the close clearance.

**813.6(4)** A close-clearance warning sign shall comply with the following requirements. A warning sign shall:

*a.* Include the words “no clearance.” The letters must be black on a white reflective background and be a minimum of 3 inches high.

*b.* Be a vertical sign not less than 42 inches in height and 4 inches in width.

*c.* Be placed at least 1 foot off the ground or on the obstruction and within 3 feet of the close-clearance location or on the obstruction. Signs shall be located on both sides of the obstruction so as to be visible from both directions.

*d.* Not be within 8 feet of the centerline of the tracks.

**813.6(5)** In the event that the placement of the close-clearance warning sign according to paragraph 813.6(4) “*c*” or 813.6(4) “*d*” does not provide adequate notice for a person who is lawfully riding the side of a train to prepare for the close clearance (such as a curve or other sight obstruction), an additional sign reading “no clearance ahead” shall be placed in a location that provides adequate notice to the person who is lawfully riding the side of the train so that the person may prepare for the close clearance. Depending on the particular environment that makes an additional no clearance ahead sign necessary, a no clearance ahead sign may be required on one or on both sides of the obstruction so as to be visible from both directions.

**813.6(6)** In the event that the physical environment prevents the placement of a warning sign in accordance with paragraph 813.6(4) “*c*” or 813.6(4) “*d*,” the sign shall be placed in a highly visible location that is clearly indicative of the point of close clearance. An alternative size and shape of sign may be used if there is no location available where a standard size and shape sign may be used. Any alternative sign must clearly be identifiable as an indicator of the close-clearance situation.

**813.6(7)** In limited situations where multiple instances of insufficient clearance occur within a confined area or over a distance, and where posting of multiple warning signs could on its own be a safety hazard, or where multiple signs would create a confusing environment making it difficult to discern the areas that lack clearance, a sign reading “no clearance ahead” may be posted in lieu of multiple signs.

**813.6(8)** A line or other marker shall be maintained at a distance of 8 feet from the centerline of the track on all platforms, excluding passenger platforms, to indicate the space along the edge of such platform that shall be kept clear of merchandise, material, or other articles that could create a temporary close-clearance situation.

**813.6(9)** Placement of a warning sign does not relieve the owner from any duties required under Iowa Code chapter 317 or Iowa Code section 327F.27.

[ARC 8202B, IAB 10/7/09, effective 11/11/09]

**761—813.7 and 813.8** Reserved.

**761—813.9(327F) Enforcement.**

**813.9(1)** If the owner is provided written notice by an employee, a person working on or near the tracks, or a railroad inspector that a location is in need of a close-clearance warning sign, the owner shall investigate and, if warranted, ensure the placement of a warning sign or signs within 30 calendar days of notification. If a close-clearance warning sign is not warranted, the owner shall inform the person who provided notice, in writing within 30 calendar days, that a sign is not warranted and shall explain why the location does not need a close-clearance warning sign.

**813.9(2)** If the owner fails to respond to a written notice by an employee or another person working on or near the tracks, or if the employee or other person disagrees with the owner’s determination that a warning sign is not warranted, the employee or other person may notify the department. The department shall investigate and make a determination if the location warrants the placement of a close-clearance warning sign.

*a.* If the department determines a close-clearance warning sign is warranted, the department shall notify the owner in writing. The owner shall have 14 calendar days from the date of the notification to install the proper warning

sign. Failure to install the close-clearance warning sign is evidence that the owner is in violation of Iowa Code section 327F.13.

*b.* The owner, an employee or a person working on or near the tracks may contest the determination. If the determination is contested, 761—Chapter 13 applies.

[ARC 8202B, IAB 10/7/09, effective 11/11/09]

**761—813.10(327F) Reimbursement.**

**813.10(1)** The owner may request reimbursement from the department for up to \$100 per sign for the cost and installation of the close clearance or no clearance ahead warning sign.

**813.10(2)** To be reimbursed, the owner shall complete Form 291303, “Close-Clearance Warning Sign Certification,” and submit the form to the office of rail transportation. The owner must certify that the warning sign complies with the requirements in rule 761—813.6(327F) and provide proof of purchase.

**813.10(3)** The department may inspect, at any time, the sign installation to confirm that the warning sign meets the minimum requirements in rule 761—813.6(327F).

**813.10(4)** Form 291303 is available on the department’s website at [www.iowadot.gov](http://www.iowadot.gov) or from the office of rail transportation.

[ARC 8202B, IAB 10/7/09, effective 11/11/09; ARC 3881C, IAB 7/4/18, effective 8/8/18]

These rules are intended to implement Iowa Code section 327F.13.

[Filed ARC 8202B (Notice ARC 7885B, IAB 7/1/09), IAB 10/7/09, effective 11/11/09]

[Filed ARC 3881C (Notice ARC 3756C, IAB 4/25/18), IAB 7/4/18, effective 8/8/18]

CHAPTERS 814 to 819  
Reserved



CHAPTER 820  
HIGHWAY GRADE CROSSING SAFETY FUND

[Substance formerly (06,C)Ch 3]  
[Prior to 6/3/87, Transportation Department [820]—(10,B)Ch 4]

**761—820.1(327G) Definitions.** The following terms when used in this chapter of rules shall have the following meanings:

“*AAR signal unit*” means the relative maintenance difficulty value assigned to component parts of an active warning device. Units and interpretations are designated by the 2021 Revision of the American Railway Engineering and Maintenance-of-Way Association (AREMA) Communications and Signals Manual, Volume 1, Section 1 (1.3.2) [Recommend Table of Signal and Interlocking Units and Interpretations].

“*Active warning devices*” means traffic control devices activated by the approach or presence of a train, such as flashing light signals, flashing light signals with cantilever assemblies, and flashing light signals with automatic gate arms, all of which actively warn motorists of a train.

“*Maintenance costs of active warning devices*” means costs incurred by a railroad associated with the repair or replacement of obsolete, worn out, damaged, or missing component parts of an approved active warning device. Maintenance costs shall include repair or replacement of damaged, vandalized, or stolen component parts only for that amount which exceeds the amount recovered from the liable party or the liable party’s insurer.

“*Safety fund*” means the highway grade crossing safety fund established in Iowa Code section 327G.19 and administered by the department.

[ARC 6710C, IAB 11/30/22, effective 1/4/23]

**761—820.2(327G) Purpose.** The purpose of this chapter is to set out the requirements for use of the highway grade crossing safety fund to reimburse railroads for a portion of the maintenance costs associated with active warning devices.

**761—820.3(327G) Information and submissions.** Information about this chapter may be obtained by contacting the department at the following address: Modal Transportation Bureau, Iowa Department of Transportation, 800 Lincoln Way, Ames, Iowa 50010; telephone (515)239-1108. Submissions to the department under this chapter may be sent or delivered to this address or may be electronically filed with the program manager.

[ARC 6710C, IAB 11/30/22, effective 1/4/23]

**761—820.4(327G) Participation in the maintenance costs of eligible warning devices.** The highway grade crossing safety fund shall be used to participate in the annual maintenance costs of active warning devices ordered or agreed to be installed on or after July 1, 1973, as stated in the individual order or agreement.

**820.4(1)** Orders or agreements that provide for revision of the maximum amount that can be expended from the highway grade crossing safety fund by reason of amendment to Iowa Code section 327G.15 are binding. These orders and agreements were amended to read: The fund’s participation for calendar years preceding 1977 shall be equal to that of the railroad but limited to a maximum of \$450 for any one year, for any one crossing; and for calendar year 1977 and subsequent years, the fund may participate in an amount of up to 75 percent of annual maintenance costs of active warning devices, based upon a cost for each eligible AAR signal unit.

**820.4(2)** Orders or agreements issued on or after March 8, 1978, shall provide that the highway grade crossing safety fund may be used to participate in an amount of up to 75 percent of the annual maintenance costs of active warning devices, based upon a cost for each eligible AAR signal unit.

**820.4(3)** Participation in annual maintenance costs is on a reimbursement basis.

**761—820.5(327G) Reimbursement.**

**820.5(1) Calculations.** Reimbursement to a railroad for its active warning devices that are eligible for reimbursement under rule 761—820.4(327G) shall equal the number of AAR signal units for that railroad’s eligible active warning devices times the average annual maintenance cost per AAR signal unit times the percentage of participation.

a. Each railroad shall tabulate the number of AAR signal units for each eligible warning device and furnish this tabulation to the department. The department shall review the railroads’ tabulations for conformance with AAR guidelines.

b. Each year, the department shall compute an average annual maintenance cost per AAR signal unit. This unit cost shall be used by all railroads for billing purposes.

c. The percentage of participation shall not exceed 75 percent.

**820.5(2) Billing.** Before April 15 of each year, each railroad shall submit one billing to the department covering maintenance costs for the preceding calendar year for all eligible warning devices. Prior to reimbursement, the department may audit the billings to determine conformity of the billings with the orders or agreements. Reimbursement to a railroad may be denied if the railroad fails to submit its billing before April 15.

**820.5(3) Proration.**

*a.* If, in any year, the balance of the highway grade crossing safety fund is inadequate to fully reimburse all railroads, the department shall reimburse each railroad on a pro-rata basis.

*b.* If a warning device has been in operation for less than one calendar year, the maintenance costs shall be prorated from the date the device was placed in operation to the end of that calendar year.

These rules are intended to implement Iowa Code sections 327G.15 and 327G.19.

[Filed 8/24/82, Notice 7/7/82—published 9/15/82, effective 10/20/82]

[Filed 10/2/85, Notice 8/14/85—published 10/23/85, effective 11/27/85]

[Filed 5/11/87, Notice 3/11/87—published 6/3/87, effective 7/8/87]

[Filed 8/26/88, Notice 7/13/88—published 9/21/88, effective 10/26/88]

[Filed 1/10/90, Notice 11/29/89—published 2/7/90, effective 3/14/90]

[Filed 4/17/96, Notice 3/13/96—published 5/8/96, effective 6/12/96]

[Filed 7/15/03, Notice 5/14/03—published 8/6/03, effective 9/10/03]

[Filed ARC 6710C (Notice ARC 6575C, IAB 10/5/22), IAB 11/30/22, effective 1/4/23]

CHAPTER 821  
HIGHWAY-RAILROAD GRADE CROSSING SURFACE  
REPAIR FUND

[Substance formerly in (06,C)Ch 3]  
[Prior to 6/3/87, Transportation Department [820]—(10,B)Ch 5]

**761—821.1(327G) Definitions.** The following terms when used in this chapter shall have the following meanings:

“*Grade crossing surface repair*” means the partial or complete renovation of a highway-railroad grade crossing and the highway approaches to the crossing.

“*Jurisdiction*” means the authority having primary control over a highway, street, or alley.

“*Repair fund*” means the grade crossing surface repair fund established in Iowa Code section 327G.29 and administered by the department.

**761—821.2(327G) General information.**

**821.2(1)** The repair fund shall be used for grade crossing surface repair.

**821.2(2)** Program information, applications and application instructions are available on the department’s website at [www.iowadot.gov](http://www.iowadot.gov). The program is administered by the Modal Transportation Bureau, Iowa Department of Transportation, 800 Lincoln Way, Ames, Iowa 50010; telephone (515)239-1108.

[ARC 2842C, IAB 12/7/16, effective 1/11/17; ARC 6709C, IAB 11/30/22, effective 1/4/23]

**761—821.3(327G) Procedures for the use of grade crossing surface repair funds.**

**821.3(1)** *Use of funds.* A portion of the repair fund, not to exceed 50 percent in any fiscal year, shall be set aside to meet critical or atypical needs. In identifying priorities for the set-aside funds, criteria including, but not limited to, the following shall be considered:

- a. Condition of the crossing.
- b. Safety concerns.
- c. Utilization of the rail line.
- d. Train and motor vehicle traffic density at the site. Special consideration may be given to heavy truck traffic.
- e. Recent or planned development or construction in the vicinity of the crossing.

**821.3(2)** *Notification to department.* If a railroad and a jurisdiction agree to use the repair fund for grade crossing surface repair, written notification of the action signed by both parties shall be sent to the department.

a. The notification shall include the American Association of Railroads—Department of Transportation (AAR-DOT) crossing number, the total estimated cost of the repair, and a statement that the railroad and the jurisdiction each agree to pay 20 percent of the cost of the repair.

b. Notification shall be accepted by the department in order of receipt.

**821.3(3)** *Processing an agreement.*

a. The department shall determine if the agreed-upon work constitutes grade crossing surface repair and may consult with the jurisdiction or the railroad if further information is needed.

b. If the work constitutes grade crossing surface repair and when funds are available in the repair fund, the department shall request that the jurisdiction and railroad provide cost estimates for the work for which each party is responsible. Upon receipt of the estimates, the department will furnish an agreement for grade crossing surface repair to the railroad and jurisdiction.

c. The railroad and the jurisdiction shall sign the agreement and return it to the department.

d. The department shall:

(1) Approve the agreement and obligate from the repair fund an amount equal to 60 percent of the cost of the agreed-upon work.

(2) Sign the agreement, retain one copy of the fully executed agreement, transmit one copy to the jurisdiction, and transmit one copy to the railroad, authorizing work to proceed.

**821.3(4)** *Preaduit.* Prior to approval of the agreement, the department may perform a preaudit evaluation of the railroad.

The preaudit evaluation may include an examination of the railroad’s accounting methods and procedures to determine the railroad’s ability to segregate and accumulate costs to be charged against the surface repair project; an examination of the railroad’s cost factors to ensure their propriety and allowability; and an examination of any other general information available which might be pertinent or necessary in determining the railroad’s auditability.

**821.3(5)** *Review of completed project.* Upon completion of the agreed-upon work, the department, the railroad and the jurisdiction shall review the project to determine satisfactory completion.

**821.3(6)** *Project billing and payment.*

*a.* The railroad shall submit to the jurisdiction and the department a final detailed billing covering the actual and necessary costs incurred by the railroad for the agreed-upon work.

*b.* The jurisdiction and the department shall review the billing for reasonable conformance with the agreement. The department may audit the billing to determine the allowability and propriety of the billing costs in accordance with the agreement.

*c.* Once the department approves the billing, the department shall pay to the railroad from the repair fund an amount equal to 60 percent of the actual project cost of the agreed-upon work.

*d.* The jurisdiction shall pay to the railroad an amount equal to 20 percent of the actual cost of the agreed-upon work.

[ARC 2842C, IAB 12/7/16, effective 1/11/17; ARC 6709C, IAB 11/30/22, effective 1/4/23]

These rules are intended to implement Iowa Code sections 312.2(2), 327G.29 and 327G.30.

[Filed 8/24/82, Notice 7/7/82—published 9/15/82, effective 10/20/82]

[Filed emergency 7/7/83—published 8/3/83, effective 7/7/83]

[Filed 10/2/85, Notice 8/14/85—published 10/23/85, effective 11/27/85]

[Filed 5/11/87, Notice 3/11/87—published 6/3/87, effective 7/8/87]

[Filed 7/15/03, Notice 5/14/03—published 8/6/03, effective 9/10/03]

[Filed ARC 2842C (Notice ARC 2751C, IAB 10/12/16), IAB 12/7/16, effective 1/11/17]

[Filed ARC 6709C (Notice ARC 6574C, IAB 10/5/22), IAB 11/30/22, effective 1/4/23]

CHAPTER 822  
RAILROAD REVOLVING LOAN AND GRANT FUND PROGRAM

[Prior to 7/1/09, see 765—Ch 5]

**761—822.1(327H) Introduction and purpose.** The railroad revolving loan and grant fund program provides funding in the form of loans and grants for railroad-related improvement projects. The purpose of the program is to spur economic development and job growth and provide benefits to Iowa through economic benefits derived from railroad transportation system or service improvements. The railroad revolving loan and grant fund is established in Iowa Code section 327H.20A and is under the control of the department.

[ARC 7909B, IAB 7/1/09, effective 7/1/09; ARC 3883C, IAB 7/4/18, effective 8/8/18]

**761—822.2(327H) Definitions.**

“*Rail facilities*” includes railroad main lines, branch lines, switching yards, sidings, rail connections, transload yards, intermodal yards, highway grade separations, railroad bridges, railroad scales and other railroad infrastructure.

“*Rail port*” means a commercial or industrial development that has the potential to provide rail service to multiple users through shared rail infrastructure, including transload or intermodal yards.

[ARC 7909B, IAB 7/1/09, effective 7/1/09; ARC 3883C, IAB 7/4/18, effective 8/8/18]

**761—822.3(327H) Information.** Program information and application forms are available on the department’s website at [www.iowadot.gov](http://www.iowadot.gov). Completed applications shall be submitted as directed in the application materials. Assistance may be obtained at the following address: Modal Transportation Bureau, Iowa Department of Transportation, 800 Lincoln Way, Ames, Iowa 50010; telephone (515)239-1066.

[ARC 7909B, IAB 7/1/09, effective 7/1/09; ARC 3883C, IAB 7/4/18, effective 8/8/18; Editorial change: IAC Supplement 8/24/22]

**761—822.4(327H) Purpose of program.** Rescinded ARC 3883C, IAB 7/4/18, effective 8/8/18.

**761—822.5(327H) Funding.**

**822.5(1)** The transportation commission is responsible for determining the projects to be funded and the amount of funding for each project.

**822.5(2)** The minimum amount of matching funds required of an applicant is 20 percent of the project cost.

**822.5(3)** Rescinded IAB 7/1/09, effective 7/1/09.

[ARC 7909B, IAB 7/1/09, effective 7/1/09]

**761—822.6(327H) Project criteria.** Rescinded ARC 3883C, IAB 7/4/18, effective 8/8/18.

**761—822.7(327H) Applicant eligibility.** A railroad company, railroad user, city, county, metropolitan planning organization, regional planning affiliation, or any other entity with an interest in a rail transportation improvement is eligible to apply for funding. The applicant shall be fiscally responsible for any awarded loans or grants. Joint applications are allowed and encouraged, but joint applications shall designate one entity that shall be fiscally responsible for any awarded loans or grants.

[ARC 7909B, IAB 7/1/09, effective 7/1/09; ARC 3883C, IAB 7/4/18, effective 8/8/18]

**761—822.8(327H) Eligible and ineligible project costs.**

**822.8(1) *Eligible costs.*** Activities or items eligible for funding include, but are not limited to, the following:

- a. Modernization, upgrading or reconstruction of existing rail facilities or rail ports.
- b. Construction of new rail facilities or rail ports.
- c. Railroad bridge and culvert modernization, replacement or removal.
- d. Right-of-way acquisition costs.
- e. Feasibility studies or planning studies for proposed projects that are otherwise eligible.
- f. Loan development costs that a Class II or III railroad may have in obtaining a loan for a project that would have otherwise qualified under this chapter.

**822.8(2) *Ineligible costs.***

a. The following activities or items are ineligible for funding:

- (1) Contract administration.
- (2) Freight car or locomotive lease, purchase or repair.
- (3) Refinancing of a completed project that would have otherwise qualified under this chapter.
- (4) Facilities solely used for historical or tourist railroad activities.
- (5) Capital or operating costs associated with passenger rail, commuter rail or public transit.

- (6) Acquisition or capital costs associated with recreational trails.
- b. The following costs are ineligible unless the costs are part of a larger construction award under this program:
  - (1) Design and engineering.
  - (2) Environmental studies.
  - (3) At-grade crossing surface repair or replacement.
  - (4) Signals, gates or other crossing protection.

**822.8(3) Advance eligibility exemption.** No part of a project may be under construction prior to a signed and executed agreement. Certain preliminary costs may be eligible for an advance eligibility exemption, if the exemption is requested in writing and granted by the department in writing. If granted, an exemption will permit a specified expenditure by the applicant without jeopardizing the project's eligibility for future funding approval. Granting an exemption shall not imply or guarantee that the department will fund a subsequent application. An advance eligibility exemption must be requested and approved prior to the expenditure; any cost incurred before a written exemption is granted will be ineligible for reimbursement.

[ARC 7909B, IAB 7/1/09, effective 7/1/09; ARC 3883C, IAB 7/4/18, effective 8/8/18]

**761—822.9** Reserved.

**761—822.10(327H) Project application.**

**822.10(1) Submission.** Applications may be submitted at any time and will be held until the next evaluation cycle.

a. A notice of funding availability will be published on the department's website when funding is available. The notice will include the approximate amount of funding available and a deadline for consideration of applications.

b. An applicant shall submit the appropriate application on the prescribed forms either electronically to the email address included in the application or to the address in rule 761—822.3(327H).

c. If an application is incomplete, department staff shall return the application to the applicant to be resubmitted when it is complete.

d. An application may be withdrawn at any time after submission.

**822.10(2) Contents of application.** Each application shall contain the following:

a. The applicant's name, address, telephone number, facsimile number and email address (if available) and the name of a designated contact person for the project.

b. A detailed description of the project proposed for funding, including a location map and a project plan or drawing.

c. The justification for the project, including the following information:

(1) The need for and purpose of the project.

(2) Specific information demonstrating that the proposed project will provide benefits to Iowa in terms of direct economic development and job growth or retention or through economic transportation or other benefits derived from railroad transportation system or service improvements. Benefits are to be quantified whenever possible.

d. An itemized estimate of all project or planning study costs and the proposed match or cost sharing based on the requested funding. A detailed financial plan to explain the funding for the entire project should be included, along with any associated development costs.

e. A time schedule for the completion of the project.

f. The total amount of loan and grant funds requested.

g. If loan funds are requested, a detailed description of the applicant's ability to repay the loan. Department staff may require the applicant to provide audited financial statements for the past two years plus a current balance sheet and profit/loss statement for the entity that is to repay the loan. If the entity that is to repay the loan is a new entity, the applicant shall, instead, provide a pro forma balance sheet and pro forma profit/loss statement.

h. If requested by department staff, endorsement of the project by a local government(s) that will be affected by the project and a description of how the project will impact the local government's transportation and economic development plans.

i. If the project is a new or expanded development, a letter from the serving railroad(s) indicating that the railroad(s) will serve the planned development.

[ARC 7909B, IAB 7/1/09, effective 7/1/09; ARC 3883C, IAB 7/4/18, effective 8/8/18]

**761—822.11(327H) Project evaluation and approval.**

**822.11(1) Staff review.** Department staff shall review the contents of each application and request any additional information necessary to understand the scope and benefits of a project. Projects involving job creation which do not

meet 100 percent of the annual laborshed wage rate for their area will not be considered. Department staff may visit the project site and may require the applicant to verify the information in the application. After department staff determines that the application is complete, the staff shall develop a funding recommendation and shall schedule the project for submission to the transportation commission for approval.

**822.11(2) *Commission evaluation.*** The transportation commission shall be responsible for selecting and determining the funding for each project, subject to the availability of railroad revolving loan and grant funds. The transportation commission may fund all or part of a project and may make funding dependent upon the applicant's adherence to a time schedule or fulfillment of specified conditions, including job creation commitments.

**822.11(3) *Commission approval.*** In making its decision to fund a project, the transportation commission may consider the railroad transportation service benefits of the project, the economic development benefits of the project, the applicant's total capital investment, the number of direct and indirect jobs to be created or retained by the project, the financing requested, an analysis of public benefits versus public costs, and other potential impacts or benefits of the project.

[ARC 7909B, IAB 7/1/09, effective 7/1/09; ARC 3883C, IAB 7/4/18, effective 8/8/18]

**761—822.12(327H) Award acceptance.** After the transportation commission approves the project, department staff shall notify the applicant of the amount of the award. The applicant shall either accept or reject the award in writing within 45 days.

[ARC 3883C, IAB 7/4/18, effective 8/8/18]

**761—822.13(327H) Project agreement and administration.**

**822.13(1) *Agreement.*** After the applicant has accepted the award for a project, department staff shall negotiate and execute an agreement with the applicant. Department staff shall administer the agreement.

*a.* The agreement shall specify the scope of the project, the approved funding level, and other conditions for project funding.

*b.* As applicable, the agreement shall address responsibilities for consultant selection, project design, right-of-way acquisition, contracting, construction and materials inspection; documentation required for reimbursement of project costs; loan repayment terms; audit requirements; and maintenance of the completed project.

*c.* The applicant shall execute the agreement within 180 days following the acceptance of the award. The applicant may request an extension, and department staff may approve an extension for good cause. Failure to execute an agreement within the specified time may result in forfeiture of the award.

**822.13(2) *Reimbursement.*** The applicant will be reimbursed for eligible project costs in accordance with the agreement.

**822.13(3) *Audits.***

*a.* Prior to execution of the agreement, department staff may perform a preaudit evaluation of the applicant or others as defined in the agreement. A preaudit evaluation typically includes an examination of accounting methods to determine the applicant's ability to segregate and accumulate costs to be charged against the project, and an analysis of costs factors to ensure their propriety and allowability.

*b.* Department staff may conduct a final audit of all project costs.

**822.13(4) *Remedies for noncompliance with project agreement.*** The commission may revoke a funding commitment, require repayment of funds loaned or granted or take both actions when the applicant has not fulfilled the terms of the project agreement.

[ARC 7909B, IAB 7/1/09, effective 7/1/09; ARC 3883C, IAB 7/4/18, effective 8/8/18]

These rules are intended to implement Iowa Code section 327H.20A.

[Filed 11/15/05, Notice 9/28/05—published 12/7/05, effective 1/11/06]

[Filed Emergency ARC 7909B, IAB 7/1/09, effective 7/1/09]

[Filed ARC 3883C (Notice ARC 3759C, IAB 4/25/18), IAB 7/4/18, effective 8/8/18]

[Editorial change: IAC Supplement 8/24/22]



CHAPTERS 823 to 829

Reserved

CHAPTER 830

RAIL ASSISTANCE PROGRAM

[Prior to 6/3/87, Transportation Department [820]—(10,C)Ch 1]

Rescinded IAB 4/11/07, effective 5/16/07

CHAPTER 831

RAILROAD REVOLVING LOAN FUND

Rescinded IAB 4/11/07, effective 5/16/07

CHAPTERS 832 to 839

Reserved

CHAPTER 840

RAIL RATE REGULATION

Rescinded IAB 5/5/99, effective 6/9/99

CHAPTERS 841 to 899

Reserved

*PUBLIC TRANSIT*

CHAPTER 900

CONTRACTS SET ASIDE FOR  
DISADVANTAGED BUSINESS ENTERPRISES

[Prior to 6/3/87, Transportation Department [820]—(09,A)Ch 1]

Rescinded IAB 9/28/94, effective 11/2/94

CHAPTERS 901 to 909

Reserved



CHAPTER 910  
COORDINATION OF PUBLIC TRANSIT SERVICES  
[Prior to 6/3/87, Transportation Department [820]—(09,A)Ch 2]

**761—910.1(324A) Definitions.** For purposes of this chapter, the following definitions shall apply in addition to the definitions in Iowa Code section 324A.1:

“*Council*” means the statewide transportation coordination advisory council formed in rule 910.3(324A).

“*Department*” means the state department of transportation. The department’s modal transportation bureau administers Iowa Code chapter 324A.

“*Emergency transportation*” means transportation provided when life, health or safety is in danger, such as ambulance or law enforcement transportation.

“*Incidental transportation*” means the provision of transit rides when existing public transportation services cannot meet demand. Allowable charter service and meal deliveries are examples of incidental transportation.

“*Provider*” means any recipient of direct or indirect, state, federal or local funds, including a public transit system, that provides or contracts for public transit services.

“*Public school transportation*” means passenger transportation provided by or for a legally organized Iowa public school district for school district purposes.

“*Public transit service*” means any publicly funded passenger transportation for the general public or for specific client groups not including exclusive public school transportation, emergency transportation or incidental transportation or transportation provided by the department of health and human services or department of corrections on the grounds of the following institutions:

- State training school, Eldora;
- Cherokee mental health institute;
- Independence mental health institute;
- Glenwood state hospital-school;
- Woodward state hospital-school;
- Iowa veterans home, Marshalltown;
- Iowa state penitentiary, Fort Madison;
- Anamosa state penitentiary, Anamosa;
- Iowa correctional institution for women, Mitchellville;
- Mount Pleasant correctional facility, Mount Pleasant;
- Newton correctional facility, Newton;
- Iowa medical and classification center, Coralville;
- North central correctional facility, Rockwell City;
- Fort Dodge correctional facility, Fort Dodge;
- Clarinda correctional facility, Clarinda.

This rule is intended to implement Iowa Code section 324A.1.

[ARC 3690C, IAB 3/14/18, effective 4/18/18; Editorial change: IAC Supplement 11/29/23]

**761—910.2(17A) Information and location.** Forms or information about the coordination of public transit services are available from the Modal Transportation Bureau, Iowa Department of Transportation, 800 Lincoln Way, Ames, Iowa 50010; telephone 515.233.7870 or on the department’s website at [www.iowadot.gov](http://www.iowadot.gov).

This rule is intended to implement Iowa Code section 17A.3.

[Editorial change: IAC Supplement 2/23/11; ARC 3690C, IAB 3/14/18, effective 4/18/18; Editorial change: IAC Supplement 11/29/23]

**761—910.3(324A) Statewide transportation coordination advisory council.**

**910.3(1) Purpose.** An advisory council shall be formed by the department to assist with implementation of the compliance reviews required by statute. The council shall assist in the review of information concerning the transportation operations of providers and advise the department as to whether the provider should be found to be in compliance with the transportation coordination mandate of Iowa Code chapter 324A.

**910.3(2) Advisory council.**

*a. Membership.* Membership in the council shall at minimum include one representative from the department of health and human services and one from the department. Other state agencies as well as federal agencies and statewide private agencies funding local transportation services may also be granted membership.

*b. Chairperson.* The director of transportation or the director’s representative shall serve as chairperson of the council.

*c. Staff.* Staff support for council activities shall be provided by the department.

*d. Meetings.* Meetings shall be held at least once each quarter and may be held more frequently if necessary to enable the council to expeditiously discharge its duties.

**910.3(3) Duties.** The council shall:

*a.* Review and make recommendations to the member agencies concerning guidelines and criteria for the review process operated by the council.

*b.* Provide the department with written recommendations for findings of compliance or noncompliance with the transportation coordination mandate of Iowa Code chapter 324A for individual providers based upon review of each provider's request for certification.

*c.* Upon request of a member agency, review all transportation components of funding applications or plans submitted by a recipient of the member agency.

*d.* Advise and make recommendations to the department concerning public transportation policy.

This rule is intended to implement Iowa Code sections 324A.4 and 324A.5.

[Editorial change: IAC Supplement 2/23/11; ARC 3690C, IAB 3/14/18, effective 4/18/18; Editorial change: IAC Supplement 11/29/23]

#### **761—910.4(324A) Certification process.**

**910.4(1) Requirement for certification.** All providers are required to request a certification of compliance with the transportation coordination mandate of Iowa Code chapter 324A by submitting the certification application form in the Appendix to this rule plus a copy of a certificate of insurance or documentation of self-insurance. Agencies that provide a mixture of public transit service and other service shall request certification based on that part of their overall operation which is public transit service.

**910.4(2) Form distribution.**

*a. Recipients of state or state-administered funds.* Each state agency in its own funding application or contract process shall require each recipient of funding to submit a request for certification of compliance.

*b. Recipients of other funds.* The department shall contact local governments and federal agencies to determine whether they are funding any providers that are not funded through the state. The department shall send to any providers identified in this way, or by other means, an explanation of the certification requirement and a copy of the certification request form in the Appendix.

**910.4(3) Submission of request forms.**

*a.* Recipients of state funds shall submit both the certification application and the certificate of insurance forms annually to the funding agency.

*b.* Recipients of funds from multiple sources may submit a single request form to all state funding sources if it covers all agency transportation functions.

*c.* Providers not receiving any funds from state agencies shall return their completed forms within 20 working days of receipt.

*d.* Agencies or organizations that receive a form from the department and believe that none of their services fit the definition of public transit services shall respond to the department within 20 working days of receipt, stating this belief and providing a brief description of any passenger transportation service they do provide and why it should not be considered public transit service.

**910.4(4) Incomplete or unreturned request forms.**

*a.* Forms submitted to a state funding agency as part of a funding application shall be reviewed for completeness by that agency within 10 working days.

*b.* Forms submitted directly to the department by its recipients or by providers not receiving state or state-administered funds shall be reviewed for completeness by the modal transportation bureau within 10 working days.

*c.* The reviewing agency shall inform the provider in writing of any information deficiencies and allow 10 working days from receipt for submittal of missing information.

*d.* Each state agency shall report to the council each case in which a provider has failed upon notification to supply the required information within the required time frame.

*e.* All completed request forms submitted to state funding agencies shall be forwarded to the council staff within five working days after verifying completeness.

**910.4(5) Processing requests.**

*a.* The council staff shall evaluate completed requests based on the compliance standards found in rule 910.5(324A) and make a recommendation for a finding of compliance or noncompliance to the council within 20 working days of receiving the completed request form.

*b.* Ten working days prior to the council's scheduled monthly meeting, the council staff shall distribute to each council member and to the respective providers a meeting agenda and copies of all compliance finding recommendations completed since the previous agenda mailing.

*c.* At their monthly meeting the council shall consider the compliance finding recommendations of the staff and may accept the staff recommendations as their recommendations to the director of transportation, change the recommendations and provide a statement of reasons, or defer action pending further review.

*d.* Upon consideration of the council recommendations, the department shall make a final finding of compliance or noncompliance and notify the provider and the state funding agency, if applicable, in writing of the department's decision within five working days after the council meeting.

This rule is intended to implement Iowa Code section 324A.4.

[ARC 3690C, IAB 3/14/18, effective 4/18/18; Editorial change: IAC Supplement 11/29/23]

<sup>1</sup> See Appendix at end of Chapter 910.

**761—910.5(324A) Standards for compliance.** A provider shall be found compliant if the provider meets both of the following standards:

**910.5(1)** All vehicles used for the public transit services it provides or contracts for are insured for \$1 million per accident for all hazards or the provider maintains a self-insurance fund adequate to provide equivalent protection.

**910.5(2)** The provider:

*a.* Purchases all services from a designated public transit system, or

*b.* Operates all services open to the public under contract with and under control of a designated transit system,

or

*c.* Purchases all services from a private-for-profit operator of public transit services, or

*d.* Operates its own services which:

(1) The designated public transit system is currently unable to provide, or

(2) When considered as a whole using fully allocated costs, prove to be more economical than the purchase of equivalent services from the designated public transit system.

*e.* Uses a combination of services in paragraphs "*a*," "*b*," "*c*," and "*d*."

This rule is intended to implement Iowa Code section 324A.4.

[ARC 3690C, IAB 3/14/18, effective 4/18/18]

**761—910.6(324A) Noncompliance.** A provider shall be found noncompliant if:

**910.6(1)** The provider has not submitted required data upon expiration of either the original submittal deadline or the additional ten-day grace period after written notification of deficiencies in an original submittal.

**910.6(2)** The provider's request for certification has been processed and the provider did not qualify for a finding of compliance.

This rule is intended to implement Iowa Code section 324A.4.

**761—910.7(324A) Noncompliant sanctions.** A provider that is denied certification and continues the noncompliant activities for more than 30 days shall be subject to the penalties and sanctions specified in Iowa Code subsection 324A.5(3).

**910.7(1)** If the department of health and human services purchases services from the noncompliant provider, the modal transportation bureau shall notify the department of health and human services of the noncompliant finding.

**910.7(2)** If the noncompliant provider is a recipient of public funds from other than the department of health and human services, the department shall notify the proper authority as required in Iowa Code section 324A.5.

This rule is intended to implement Iowa Code sections 324A.4 and 324A.5.

[ARC 3690C, IAB 3/14/18, effective 4/18/18; Editorial change: IAC Supplement 11/29/23]

**761—910.8(324A) Revocation.**

**910.8(1)** If certification is revoked, the department shall send a written notice of revocation to the provider.

**910.8(2)** The affected public transit system, the provider and the department shall meet within 10 days after the date of the revocation notice to determine an acceptable amendment of the transportation services. The amendments which are agreed upon shall become effective within 60 days. The contract between the provider and the affected public transit system shall be amended, if necessary, to agree with the service changes.

**910.8(3)** If the transportation services are not amended in a timely manner, the department shall initiate actions as required in Iowa Code section 324A.5(2).

This rule is intended to implement Iowa Code section 324A.5.

[ARC 3690C, IAB 3/14/18, effective 4/18/18]

Appendix to rule 761—910.4(324A)

Date \_\_\_\_\_

FY \_\_\_\_\_

**CERTIFICATION APPLICATION**

State/Federal Administering Agency \_\_\_\_\_

**I. GENERAL INFORMATION:**

Agency Name: \_\_\_\_\_

Address: \_\_\_\_\_

Contact Person: \_\_\_\_\_ Phone:(\_\_\_\_\_) \_\_\_\_\_

Service Area (counties): \_\_\_\_\_

Types of Clients: \_\_\_\_\_

Types of Services: \_\_\_\_\_

Does agency provide transportation services? Yes \_\_\_\_\_ No \_\_\_\_\_

Does agency use public funds for transportation? Yes \_\_\_\_\_ No \_\_\_\_\_

**II. TRANSPORTATION ACTIVITIES:**

Population groups served: Elderly \_\_\_\_\_ Youth Economically Deprived \_\_\_\_\_ Public \_\_\_\_\_

Persons with physical disabilities \_\_\_\_\_ Persons with mental disabilities \_\_\_\_\_ Other \_\_\_\_\_

Describe others: \_\_\_\_\_

Services Accessed: Medical \_\_\_\_\_ Day Care \_\_\_\_\_ Shopping \_\_\_\_\_ Nutrition \_\_\_\_\_ Employment \_\_\_\_\_

Recreation \_\_\_\_\_ Education/training \_\_\_\_\_ Other social services \_\_\_\_\_

What percent of your transportation service (in terms of miles driven) is operated during the following time periods?

\_\_\_\_\_ % weekdays + \_\_\_\_\_ % evenings + \_\_\_\_\_ % weekends = 100%

Is any part of agency's transportation purchased from an urban or regional transit system?

Yes \_\_\_\_\_ No \_\_\_\_\_ If yes, please indicate system:

\_\_\_\_\_



**V. PURCHASE OF SERVICE (Contracts and Vendor Agreements):**

**Total \$** \_\_\_\_\_

|                               | Average Monthly Ridership | Average Monthly Vehicle Miles | Projected Annual Expenditures |
|-------------------------------|---------------------------|-------------------------------|-------------------------------|
| Taxi                          |                           |                               | \$                            |
| Intracity bus                 |                           |                               | \$                            |
| Regional/Urban Transit System |                           |                               | \$                            |
| Other - specify               |                           |                               | \$                            |
| Total                         | -----                     | -----                         | \$                            |

**VI. OPERATION OF OWN TRANSPORTATION SERVICE:**

**Total \$** \_\_\_\_\_

| STAFF                    | Number | % of Time | Projected Annual Expenditures |
|--------------------------|--------|-----------|-------------------------------|
| Administrative           |        |           | \$                            |
| Drivers                  |        |           | \$                            |
| Maintenance              |        |           | \$                            |
| Professional             |        |           | \$                            |
| Escorts                  |        |           | \$                            |
| Volunteers reimbursement |        | \$ /mile  | \$                            |
| Other - specify          |        |           | \$                            |
| Subtotal                 | -----  | -----     | \$                            |

| VEHICLE OPERATING COSTS              | Projected Annual Expenditures |
|--------------------------------------|-------------------------------|
| Fuel and oil                         | \$                            |
| Maintenance and repair               | \$                            |
| Insurance                            | \$                            |
| Licenses and fees                    | \$                            |
| Staff mileage reimbursement \$ /mile | \$                            |
| Indirect cost or overhead            | \$                            |
| Other - specify                      | \$                            |
| Subtotal                             | \$                            |

**PURCHASE OR LEASE OF VEHICLES AND SPECIAL EQUIPMENT**

| Vehicle Type | No. to be Leased | No. to be Purchased | No. for Replacement | No. for Expansion | Special Equipment | Projected Annual Cost |
|--------------|------------------|---------------------|---------------------|-------------------|-------------------|-----------------------|
|              |                  |                     |                     |                   |                   | \$                    |
|              |                  |                     |                     |                   |                   | \$                    |
|              |                  |                     |                     |                   |                   | \$                    |
| Subtotal     | -----            | -----               | -----               | -----             | -----             | \$                    |

**Note: The total funding in Section IV must equal the total expenditures in Section V plus Section VI.**

[Filed 3/8/85, Notice 1/16/85—published 3/27/85, effective 5/1/85]

[Filed 2/20/86, Notice 1/1/86—published 3/12/86, effective 4/16/86]

[Filed 5/11/87, Notice 3/11/87—published 6/3/87, effective 7/8/87]

[Filed 11/3/88, Notice 9/21/88—published 11/30/88, effective 1/4/89]

[Filed 1/15/92, Notice 12/11/91—published 2/5/92, effective 3/11/92]

[Filed emergency 7/1/92—published 7/22/92, effective 7/27/92]

[Filed 11/20/92, Notice 10/14/92—published 12/9/92, effective 1/13/93]

[Filed 9/8/94, Notice 7/20/94—published 9/28/94, effective 11/2/94]

[Editorial change: IAC Supplement 2/23/11]

[Filed ARC 3690C (Notice ARC 3533C, IAB 1/3/18), IAB 3/14/18, effective 4/18/18]

[Editorial change: IAC Supplement 11/29/23]

CHAPTER 911  
SCHOOL TRANSPORTATION SERVICES PROVIDED  
BY REGIONAL TRANSIT SYSTEMS

**761—911.1(321) Purpose and information.**

**911.1(1) Purpose.** This chapter establishes standards for school transportation services provided by Iowa's regional transit systems under contract with local schools.

**911.1(2) Information.** Information and forms may be obtained from the Modal Transportation Bureau, Iowa Department of Transportation, 800 Lincoln Way, Ames, Iowa 50010; telephone 515.233.7870; or the department's website at [www.iowadot.gov](http://www.iowadot.gov).

[ARC 3691C, IAB 3/14/18, effective 4/18/18; ARC 6708C, IAB 11/30/22, effective 1/4/23; Editorial change: IAC Supplement 11/29/23]

**761—911.2(321,324A) Definitions.** For the purpose of these rules, the following definitions apply:

“*Automobile*” means the same as defined in Iowa Code section 321.1(42) “d.”

“*Bus*” means a motor vehicle, excluding a trailer, designed to carry ten or more persons.

“*Contract*” means a written agreement between a public or nonpublic school or other group and a regional transit system which defines the terms and conditions under which school transportation service is to be provided. It shall not include the relationship between a regional transit system and an individual fare-paying passenger in either fixed route or demand response service.

“*Multipurpose vehicle*” means the same as defined in Iowa Code section 321.1.

“*Public transit system*” means the same as defined in Iowa Code section 324A.1.

“*Regional transit system*” means the same as defined in Iowa Code section 324A.1.

“*School bus*” means a bus that complies with all federal motor vehicle safety standards applicable to a school bus.

“*School transportation service*” means transit service provided under contract to a public or nonpublic school or other group, including day care centers, to transport students to or from schools or school-sponsored activities.

“*Student*” means a person attending a public or nonpublic school, grades prekindergarten through high school, including a Head Start participant.

“*Vehicle*” means an automobile, multipurpose vehicle, bus or school bus as defined in this rule.

[ARC 3691C, IAB 3/14/18, effective 4/18/18; ARC 6708C, IAB 11/30/22, effective 1/4/23]

**761—911.3(321) Services to students as part of the general public.** All services provided by regional transit systems must be open to the public. This chapter shall not be construed to restrict the use of these services by any individual fare-paying passenger, in either fixed route or demand response service.

**761—911.4(321) Contracts for nonexclusive school transportation.** As common carriers in urban transportation service, regional transit systems may contract with schools, day care providers, after-school program providers, or others to provide nonexclusive school transportation service that meets the requirements of this chapter. Exclusive service contracts are prohibited.

**761—911.5(321) Adoption of federal regulations.**

**911.5(1) Code of Federal Regulations.** The department of transportation adopts the following portions of the October 1, 2023, Code of Federal Regulations, which are referenced throughout this chapter:

a. 49 CFR Part 38, Americans with Disabilities Act (ADA) Accessibility Specifications for Transportation Vehicles.

b. 49 CFR Part 571, Federal Motor Vehicle Safety Standards.

c. 49 CFR Part 655, Prevention of Alcohol Misuse and Prohibited Drug Use in Transit Operations.

**911.5(2) Obtaining copies of regulations.** Copies of these regulations are available from the state law library or online through the U.S. Government Publishing Office at [www.ecfr.gov](http://www.ecfr.gov).

[ARC 3691C, IAB 3/14/18, effective 4/18/18; ARC 6708C, IAB 11/30/22, effective 1/4/23; ARC 8055C, IAB 6/12/24, effective 7/17/24]

**761—911.6(321) Driver standards.** The following standards apply to regional transit system drivers assigned to provide school transportation service:

**911.6(1) FTA drug and alcohol testing.** Each driver is subject to the following testing for drug and alcohol usage as detailed by the Federal Transit Administration in 49 CFR Part 655, including:

a. Preemployment testing.

b. Reasonable suspicion testing.

c. Postaccident testing.

- d. Random testing.
- e. Return to duty testing.
- f. Follow-up testing.

**911.6(2) Training.** Each new driver must, before or within the first six months of assignment and at least every 24 months thereafter, complete a course of instruction approved by the department of education, in accordance with Iowa Code section 321.376.

**911.6(3) Driving record check.** The regional transit system must review the driving record of each driver prior to employment and on an annual basis.

**911.6(4) Criminal record check.** The regional transit system must conduct a criminal records review of each driver prior to employment and on an annual basis. This review verifies that the driver has no history of child abuse or other criminal activity.

**911.6(5) Driver licensing.** Each driver must be licensed appropriately for the size and type of vehicle used as provided in Iowa Code section 321.189. A Class A, B or C commercial driver's license with passenger endorsement may be required. A driver may operate the vehicle for purposes of training if the driver has the appropriate commercial learner's permit as defined in 761—Chapter 607, and the restrictions in rule 761—607.20(321) shall apply. If a commercial driver's license is not required, a Class D (chauffeur) license with passenger endorsement is required.

**911.6(6) Authorization to operate a school bus.** Each driver who transports students must have an authorization to operate a school bus issued by the department of education in accordance with Iowa Code section 321.376.

**911.6(7) Physical fitness.**

a. Each driver who transports students must undergo a physical examination by a certified medical examiner who is listed on the National Registry of Certified Medical Examiners in accordance with Iowa Code section 321.375(1)“d” and with department of education rule 281—43.15(285) or 281—43.17(285). Annually, the driver must submit the signed medical examiner's certificate to the driver's employer.

b. Upon a commercial driver's license issuance or renewal, the driver shall self-certify as to the type of driving the driver does and, if required, provide a current medical examiner's certificate to the department unless the driver's medical examiner's certification is provided to the department electronically by the Federal Motor Carrier Safety Administration pursuant to 761—paragraph 607.37(1)“a” and 761—subrule 607.50(2).

[ARC 3691C, IAB 3/14/18, effective 4/18/18; ARC 6708C, IAB 11/30/22, effective 1/4/23]

**761—911.7(321) Vehicle standards.** The following standards apply to regional transit system vehicles assigned to provide school transportation service:

**911.7(1) Vehicle construction.**

a. Each vehicle must be constructed in compliance with the federal motor vehicle safety standards for that type of vehicle as set forth in 49 CFR Part 571. The capacity rating of automobiles and multipurpose vehicles shall not be modified or altered in any way except by the original manufacturer.

b. Each bus in use must also comply with the following federal motor vehicle safety standards:

(1) Standard No. 217, Bus Emergency Exits and Window Retention and Release. Buses utilized for school transportation shall incorporate a rear emergency exit door in meeting this standard.

(2) Standard No. 220, School Bus Rollover Protection.

(3) Standard No. 221, School Bus Body Joint Strength.

(4) Standard No. 301, Fuel System Integrity.

**911.7(2) Passenger restraint/protection.** Each automobile, multipurpose vehicle or school bus must provide passenger restraint/protection devices as required for that type of vehicle in the federal motor vehicle safety standards. Each bus must meet the standards listed in either “a” through “f” below or “g” below:

a. Standard No. 207, Seating Systems.

b. Standard No. 208, Occupant Crash Protection.

c. Standard No. 209, Seat Belt Assemblies.

d. Standard No. 210, Seat Belt Assembly Anchorages.

e. Standard No. 213, Child Restraint Systems.

f. Standard No. 225, Child Restraint Anchorage Systems.

g. Standard No. 222, School Bus Passenger Seating and Crash Protection.

**911.7(3) Accessibility for persons with disabilities.** Each vehicle used for students with disabilities must comply with all applicable provisions of 49 CFR Part 38.

**911.7(4) Signage.** A vehicle must not be signed as a school bus.

**911.7(5) Department of education inspection.** Every vehicle must be inspected twice annually by the department of education school bus inspectors and officers of the Iowa state patrol to determine if the vehicle meets all vehicle standards set forth in this chapter.

The department of education will notify each regional transit system of the dates and locations of scheduled inspections. Inspections must be documented on a form prescribed jointly by the departments of transportation and education.

**911.7(6) Transfer to another public transit system.** When a public transit system purchases a used vehicle from another public transit system, the previous owner's department of education's bus inspections stickers must be removed. If the purchasing public transit system plans to use the vehicle for school transportation service, a new inspection must be performed on the vehicle.

[ARC 3691C, IAB 3/14/18, effective 4/18/18]

**761—911.8(321) Maintenance.** Regional transit system vehicles assigned to provide school transportation service must be maintained in a safe and operable condition. The following maintenance practices apply:

**911.8(1) FTA drug and alcohol testing of mechanics.** All personnel providing maintenance services on regional transit system vehicles are subject to drug and alcohol testing as required by the Federal Transit Administration in 49 CFR Part 655.

**911.8(2) Daily pretrip vehicle inspections.** Drivers of these vehicles must perform daily pretrip vehicle inspections using a form prescribed by the department. Regional transit systems must retain daily pretrip vehicle inspection reports and documentation of follow-up maintenance for one year.

**911.8(3) Annual vehicle inspection.** Maintenance personnel must annually inspect each vehicle. Regional transit systems must retain annual vehicle inspection records for one year.

[ARC 3691C, IAB 3/14/18, effective 4/18/18]

**761—911.9(321) Safety equipment.** Regional transit system vehicles assigned to provide school transportation service must carry the following safety equipment:

**911.9(1) Communication equipment.** Each vehicle must be equipped with a two-way radio, cellular telephone, or mobile data terminal tablet capable of emergency communication between the vehicle and the regional transit system's base of operations.

**911.9(2) First-aid/body fluids cleanup kit(s).** Each vehicle must be equipped with a first-aid kit of sufficient size and content for the capacity of the vehicle and, in addition, be equipped with a body fluid cleanup kit. These may be provided as separate kits or combined into one kit. The contents of the kit(s) must be contained in one or more moisture-proof and dustproof containers mounted in an accessible location within the driver's compartment and must be removable from the vehicle in an emergency.

**911.9(3) Fire extinguisher.** Each bus or school bus must be equipped with a minimum 5-pound capacity, dry chemical fire extinguisher. Each automobile and multipurpose vehicle must be equipped with an extinguisher of at least 2.5-pound capacity. Extinguishers must have a 2A-10BC rating. All fire extinguishers shall be inspected and maintained in accordance with the National Fire Protection Association requirements. The standards for portable extinguishers are available online from the National Fire Protection Association at [www.nfpa.org](http://www.nfpa.org).

**911.9(4) Seatbelt web cutter.** A seatbelt web cutter must be mounted or placed within reach of the driver.

**911.9(5) Roadside reflective triangles.** Each vehicle must be equipped with roadside reflective triangles for use in case of breakdown or emergency.

**911.9(6) Flashlight.** Each vehicle must be equipped with an operable flashlight or each driver must be assigned an operable flashlight to be in the vehicle at all times of operation.

**911.9(7) Reflective vest.** Each vehicle must be equipped with a reflective vest or each driver must be assigned a reflective vest that must be in the vehicle at all times of operation. Individual regional transit systems are to establish a policy for when the reflective vests must be worn.

[ARC 3691C, IAB 3/14/18, effective 4/18/18]

**761—911.10(321) Operating policies.** School transportation services provided by regional transit systems must be designed to maximize the safety of student riders and must, at a minimum, meet the following standards:

**911.10(1) Passenger loading/unloading.** Unless prohibited by law, students transported in vehicles other than school buses must be loaded and unloaded on the same side of the street as their residence or other origin or destination. Students may be released only to the custody of a designated school official, parent or guardian, employee of the department of health and human services, or law enforcement official, unless other arrangements are made in advance.

**911.10(2)** *Student passenger behavior and discipline policy.* Each contract for school transportation service must include a policy relating to the behavior of students while they ride in vehicles. The regional transit system or school must provide instruction to all drivers assigned to school transportation service relative to the content and application of the policy. If a student is removed from a vehicle for one or more policy violations, the student may be released only to the custody of a school official, parent or guardian, employee of the department of health and human services or a law enforcement officer. In all cases, the school must be notified immediately of any such disciplinary action, and a written report must be filed with the school describing the circumstances resulting in the removal.

**911.10(3)** *Standing prohibited.* Under no circumstances shall a student be permitted or required to stand while a vehicle is in motion. Every student must be provided an appropriate seat at all times.

**911.10(4)** *Stops at rail crossings.* Every driver must make a complete stop before driving across the tracks of any railroad crossing, in accordance with Iowa Code section 321.343.

**911.10(5)** *Accident reporting.* If a driver is involved in a collision or other incident causing or having a potential to cause injuries to students, the regional transit system must immediately notify the school of the incident. The regional transit system must file all accident reports required by law. In addition, the regional transit system must complete a school bus accident report on a form prescribed by the department of education and submit it to the school or the department of education.

**911.10(6)** *Passenger instruction/evacuation drills.* Each school must provide students assigned to school transportation service with school bus passenger safety instruction and emergency evacuation drills at least twice each school year. These evacuation drills must involve a vehicle of the same type used to provide the school transportation service.

**911.10(7)** *Special training for drivers carrying students with disabilities.* Each school contracting for school transportation services for a student with one or more disabilities must provide the regional transit system with information on any special needs of the student and, if necessary, provide the assigned driver with appropriate information and training on how to appropriately respond to the needs of the student during transit and in the event of an emergency.

**911.10(8)** *Posttrip inspection.* After each trip that had students on board, the driver must perform a posttrip inspection of the interior of the vehicle. The posttrip inspection must include a walk-through to the back of the vehicle to ensure that no sleeping or hiding children are left behind.

[ARC 3691C, IAB 3/14/18, effective 4/18/18; Editorial change: IAC Supplement 11/29/23]

These rules are intended to implement Iowa Code sections 321.1, 321.189, 321.343, 321.375, 321.376, 321.377 and 324A.1.

[Filed 6/22/00, Notice 4/19/00—published 7/12/00, effective 8/16/00]

[Filed 6/2/04, Notice 4/28/04—published 6/23/04, effective 7/28/04]

[Filed 6/14/07, Notice 5/9/07—published 7/4/07, effective 8/8/07]

[Filed ARC 3691C (Notice ARC 3534C, IAB 1/3/18), IAB 3/14/18, effective 4/18/18]

[Filed ARC 6708C (Notice ARC 6572C, IAB 10/5/22), IAB 11/30/22, effective 1/4/23]

[Editorial change: IAC Supplement 11/29/23]

[Filed ARC 8055C (Notice ARC 7745C, IAB 4/3/24), IAB 6/12/24, effective 7/17/24]

CHAPTERS 912 to 919  
Reserved



CHAPTER 920  
STATE TRANSIT ASSISTANCE  
[Prior to 6/3/87, Transportation Department [820]—(09,B)Ch 1]

**761—920.1(324A) Statement of policy.** State financial assistance to any public transit system shall be restricted to joint projects with the department that hold substantial promise of accomplishing the following goals:

**920.1(1)** Development, maintenance and improvement of transit services for the general public and for transportation disadvantaged persons.

**920.1(2)** Protection of the rights of private enterprise public transit providers, especially those providing intercity scheduled services on fixed routes.

**920.1(3)** Improvement of transit system effectiveness and efficiency.

[ARC 3194C, IAB 7/5/17, effective 8/9/17]

**761—920.2(324A) General information.** The department shall post annually the required forms and instructions for applying for state transit assistance to the department's website at [www.iowadot.gov](http://www.iowadot.gov) and notify each public transit system in Iowa of the availability. Requests for assistance and questions about application preparation should be directed to: Public Transit Bureau, Iowa Department of Transportation, 800 Lincoln Way, Ames, Iowa 50010; telephone (515)233-7870.

[Editorial change: IAC Supplement 2/23/11; ARC 3194C, IAB 7/5/17, effective 8/9/17; ARC 5497C, IAB 3/10/21, effective 4/14/21]

**761—920.3(324A) Definitions.** The definitions in Iowa Code section 324A.1, except for the definition of "urban transit system," apply to this chapter. In addition:

"*Formula assistance*" means state transit assistance appropriations minus funds reserved for special projects.

"*Joint participation agreement*" means a contract between the department and a public transit system for either operations or capital assistance needed for implementation of a transit service project or projects. Each agreement shall include, but not be limited to, a project budget, method of payment, and period of performance.

"*Project*" means a concerted set of actions that will develop, maintain, or improve one or more elements of the public transit system's service.

"*Urban transit system*" means a system designated by the department which meets the requirements of Iowa Code section 324A.1(8). To be designated as an urban transit system for the purposes of this chapter, the system must serve a city or urbanized area with a population of 20,000 or more. The system also must be managed by a board of local officials who have either been elected by the public or appointed by elected officials, and who are responsible for policy and oversight of transit services for one or more incorporated areas within Iowa.

[ARC 3194C, IAB 7/5/17, effective 8/9/17; ARC 5497C, IAB 3/10/21, effective 4/14/21]

**761—920.4(324A) Types of projects.**

**920.4(1) *Formula projects.*** A formula project may involve operations assistance, capital assistance, planning, or any combination of the three. These projects are developed, analyzed and ranked through the transit planning process which involves the following steps:

*a.* Each public transit system shall arrange with the appropriate planning agencies for a review of all projects submitted, shall ensure public participation and discussion, and shall list the projects by priority.

*b.* Each public transit system shall submit its ranked list of proposed projects to the department.

**920.4(2) *Special projects.***

*a.* Special projects are extraordinary, emergency or innovative in nature, and may include, but are not limited to, the following purposes:

(1) Expanding the scope of planning, managerial, or technical expertise.

(2) Increasing the public's awareness and understanding of transit.

(3) Enhancing the capacity for administration consolidation and service coordination.

(4) Reducing impediments to intramodal or intermodal transfers.

(5) Increasing the cooperation and coordination between private and public sectors.

(6) Developing, demonstrating, or refining a technical, procedural, or mechanical innovation that may be utilized by other public transit systems in Iowa.

(7) Responding to an emergency situation that places an extraordinary and unforeseen strain on the resources of a public transit system.

*b.* Applications for training fellowships may be submitted to the department at any time.

c. Applications for special projects are due to the department by October 1 each year. The department may announce to the public transit systems the acceptance of special project applications at other times of the year if unobligated funds are available.

[ARC 3194C, IAB 7/5/17, effective 8/9/17; ARC 5497C, IAB 3/10/21, effective 4/14/21]

#### **761—920.5(324A) Standards for projects.**

**920.5(1) Requirements for transit system.** A public transit system is eligible for project assistance if the system is in compliance with all of the following criteria:

- a. The transit system abides by all applicable state and federal laws and regulations.
- b. The transit system maintains primary documentation for all revenues and expenses for a period of at least three years.
- c. The transit system maintains the system's policies, routes, schedules, fare structure, and budget in a manner that encourages public review, responsiveness to user concerns, energy conservation, and fiscal solvency.
- d. The transit system received departmental approval of the system's plan or schedule for repayment of any loan administered by the department.
- e. The transit system accurately reports all services to be supported with project formula assistance and ensures that all services are open to the general public.

**920.5(2) Project conditions.** The department shall obligate state transit assistance for joint projects that meet the following criteria:

- a. Each project must be included in the current year of the locally adopted transportation improvement program.
- b. Each project shall contain payment criteria, through the joint participation agreement, which are mutually agreed upon by the department and the contracting officer of the transit system.
- c. Each special project shall have a preestablished basis for determining success using a specified means of performance management and shall have a detailed budget of the resources available and the assistance necessary for implementation.
- d. State assistance for a special project involving capital expense shall not exceed 85 percent of the project's total capital expense. State assistance for a special project involving operating support shall not exceed 80 percent of the project's total operating expense in the first year and 50 percent of the project's total operating expense in the second year.

**920.5(3) Items not eligible for assistance.**

- a. Administrative, operations, or capital expenses which are determined by the department to be inconsistent with department policies, public law, officially approved planning and programming documents, or inconsistent with the purpose of improving the effectiveness and quality of transit services.
- b. Development of managerial, administrative, or operational systems which duplicate programs made available at no charge to the transit system by the department.

**920.5(4) Determination of system eligibility for formula assistance.**

a. Prior to the beginning of each fiscal year, each state-designated public transit system's formula percentage shall be determined through the process shown in the appendix located at the end of this chapter.

(1) Transit system data used in determining formula percentage is based only on services which are open to the general public and is derived from the last fiscal year for which complete information is available.

(2) The process shown in the appendix establishes the percentage of available state transit assistance funds not reserved for special projects for which each transit system is eligible during the fiscal year.

b. The amount of each system's eligibility for formula assistance from this appropriation shall be determined by multiplying the system's formula percentage by the amount of the appropriation not reserved for special projects.

c. If the dollar amount of state transit assistance is not known until the funds are actually deposited in the state transit assistance account, the amount of each system's eligibility for formula assistance from these funds shall be determined as follows: At the beginning of each month, the system's formula percentage shall be multiplied by the amount of new funds not reserved for special projects that were deposited in the state transit assistance account during the previous month.

d. A transit system's eligibility for programmed project assistance may be reduced if it is subject to the sanctions outlined in Iowa Code section 324A.5 or 761—Chapter 910.

**920.5(5) Determination of amount reserved for special projects.** Each fiscal year, at least \$300,000 will be reserved from state transit assistance appropriations for special projects. Any special project funds not obligated in the previous fiscal year and any funds made available through closeout of previously approved projects may also be reserved for special projects. Special project funds are distributed by the department on a discretionary basis in accordance with subrule 920.4(2).

[ARC 3194C, IAB 7/5/17, effective 8/9/17]

**761—920.6(324A) Processing.**

**920.6(1) *Review.*** The department shall review the proposed projects.

**920.6(2) *Program.*** Based on available funds and the project priorities established by the transit systems, the department shall prepare a set of funding recommendations.

**920.6(3) *Approval and agreement.*** Upon approval of the projects by the transportation commission, the department shall prepare a joint participation agreement and send it to each public transit system for execution.

**920.6(4) *Advance payment allowed.*** Each transit system with a signed joint participation agreement may be paid formula assistance monthly, in advance of project expenditures, if all of the following conditions are met:

*a.* The transit system included in its application a request for advance allocations as set forth in Iowa Code section 324A.6.

*b.* The transit system is current on all reporting required by the department.

*c.* The transit system is current on all scheduled repayments under loan contracts from the department.

[ARC 3194C, IAB 7/5/17, effective 8/9/17]

These rules are intended to implement Iowa Code chapter 324A.

APPENDIX TO  
761—920.5(324A)

|       |  |
|-------|--|
| FP    | Formula percentage. The percentage of any state transit assistance appropriation that a public transit system is eligible to receive from the nondiscretionary portion of the appropriation. Determination of a public transit system's formula percentage shall be made using the method diagrammed in this appendix.       |
| FY    | Fiscal year. The 12-month period beginning July 1 of one year and ending June 30 of the following year.  |
| LDI   | Locally determined income. All transit system revenue dedicated for operations expense during a fiscal year, minus federal operating assistance from the U.S. Department of Transportation and minus all special project operating support and formula assistance funds received from the Iowa Department of Transportation. |
| OpExp | Operations expense. All eligible transit system expenses related to operating, maintaining, and administering transit operations.  |
| Pass  | Passenger. A person boarding a transit vehicle for the purpose of making a trip. A passenger is counted each time that person boards a vehicle for travel to a destination.  |
| RevMi | Revenue miles. Total vehicle miles traveled by revenue vehicles of public transit systems while in revenue service. Excludes miles traveled to and from storage facilities and other deadhead travel.  |

APPENDIX TO  
761—920.5(324A)  
FORMULA FOR DETERMINATION OF FORMULA PERCENTAGE

$$\begin{aligned}
 & \text{Regional} && \text{System's LDI} \\
 & \text{System's} = & .50 & \frac{\text{Regional RevMi}}{\text{Total State RevMi}} \times \frac{\text{System's LDI}}{\text{Sum of LDI for all regions}} + \\
 & \text{FP} && \\
 & && \text{System's Pass to OpExp ratio} \\
 & & .25 & \frac{\text{Regional RevMi}}{\text{Total State RevMi}} \times \frac{\text{System's Pass to OpExp ratio}}{\text{Sum of Pass to OpExp ratios for all regions}} + \\
 & && \\
 & && \text{System's RevMi to OpExp ratio} \\
 & & .25 & \frac{\text{Regional RevMi}}{\text{Total State RevMi}} \times \frac{\text{System's RevMi to OpExp ratio}}{\text{Sum of RevMi to OpExp ratios for all regions}} \\
 & && \\
 & \text{Urban} && \text{System's LDI} \\
 & \text{System's} = & .50 & \frac{\text{Urban RevMi}}{\text{Total State RevMi}} \times \frac{\text{System's LDI}}{\text{Sum of LDI for all urbans}} + \\
 & \text{FP} && \\
 & && \text{System Pass to OpExp ratio} \\
 & & .25 & \frac{\text{Urban RevMi}}{\text{Total State RevMi}} \times \frac{\text{System Pass to OpExp ratio}}{\text{Sum of Pass to OpExp ratios for all urbans}} + \\
 & && \\
 & && \text{System's RevMi to OpExp ratio} \\
 & & .25 & \frac{\text{Urban RevMi}}{\text{Total State RevMi}} \times \frac{\text{System's RevMi to OpExp ratio}}{\text{Sum of RevMi to OpExp ratios for all urbans}}
 \end{aligned}$$

[Filed 9/15/76, Notice 7/26/76—published 10/6/76, effective 11/10/76]

[Filed 2/18/82, Notice 1/6/82—published 3/17/82, effective 4/21/82]

[Filed 4/17/85, Notice 2/27/85—published 5/8/85, effective 6/12/85]

[Filed emergency 12/11/85—published 1/1/86, effective 1/1/86]

[Filed 2/20/86, Notice 1/1/86—published 3/12/86, effective 4/16/86]

[Filed 5/11/87, Notice 3/11/87—published 6/3/87, effective 7/8/87]

[Filed emergency 6/15/89 after Notice 5/3/89—published 7/12/89, effective 7/1/89]

[Filed 9/25/91, Notice 8/21/91—published 10/16/91, effective 11/20/91]

[Filed 1/15/92, Notice 12/11/91—published 2/5/92, effective 3/11/92]

[Filed emergency 7/1/92—published 7/22/92, effective 7/27/92]

[Filed 3/25/94, Notice 2/16/94—published 4/13/94, effective 5/18/94]

[Filed 9/8/94, Notice 7/20/94—published 9/28/94, effective 11/2/94]

[Editorial change: IAC Supplement 2/23/11]

[Filed ARC 3194C (Notice ARC 3034C, IAB 4/26/17), IAB 7/5/17, effective 8/9/17]

[Filed ARC 5497C (Notice ARC 5312C, IAB 12/16/20), IAB 3/10/21, effective 4/14/21]



CHAPTER 921  
ADVANCED ALLOCATIONS OF STATE TRANSIT ASSISTANCE FUNDING

[Prior to 6/3/87, Transportation Department [820]—(09,B)Ch 2]

**761—921.1(324A) Scope of chapter.** This chapter shall apply only to those transit systems eligible for and having or proposing to have a joint participation agreement in force with the department for state transit assistance funding as set forth in 761—Chapter 920. This chapter implements provisions for advance allocations of state transit assistance funding as set forth in Iowa Code section 324A.6(4). The definitions in Iowa Code section 324A.1 apply to this chapter. The requirements for the award of state funds for state transit assistance and subsequent procedures are found in 761—Chapter 920.

[ARC 3194C, IAB 7/5/17, effective 8/9/17]

**761—921.2(324A) Advance allocations.** Advance allocations of state transit assistance are paid prior to the time actual expenditures are incurred. Payment of one-twelfth (or 8.33 percent) of the total joint participation agreement amount is made prior to or during each month, starting on the execution date of the joint participation agreement.

[ARC 3194C, IAB 7/5/17, effective 8/9/17]

**761—921.3(324A) Application for advance allocations.**

**921.3(1)** Transit systems having or proposing to have a joint participation agreement with the department for state transit assistance funding may make written application for advance allocations of the joint participation agreement amount. The application shall be directed to: Public Transit Bureau, Iowa Department of Transportation, 800 Lincoln Way, Ames, Iowa 50010. Applications are available on the department's website at [www.iowadot.gov](http://www.iowadot.gov) or by telephone at (515)233-7870.

**921.3(2)** Transit systems applying for state transit assistance funding, pursuant to 761—Chapter 920, may make written application for advance allocations of a proposed or existing joint participation agreement amount as part of the application for state transit assistance.

**921.3(3)** No application for advance allocation shall be complete without:

- a. The name of the transit system.
- b. A specific statement of the reasons why an advance allocation is required by the transit system.
- c. A statement from the transit system which indicates the specific existing or proposed joint participation agreement from which advance allocations are to be derived.
- d. A statement from the transit system which indicates that the contract officer has read these administrative rules and certifies that the contract officer shall comply with them.
- e. The signature of the contract officer of the transit system, and the date of the signature.

[Editorial change: IAC Supplement 2/23/11; ARC 3194C, IAB 7/5/17, effective 8/9/17; Editorial change: IAC Supplement 2/24/21]

**761—921.4(324A) Application approval.** The department shall review all applications for advance allocations of state transit assistance. The department shall also approve, disapprove or defer all such applications. Provisions of applications which are approved shall be written into and made a part of the transit system's state transit assistance joint participation agreement, if it is in effect, or written into such joint participation agreement when awarded by the department pursuant to 761—Chapter 920. The transit system shall be so notified of such action. Transit systems whose applications for advance allocations are disapproved or deferred shall be so notified by the department, including the reason(s) for such actions.

[ARC 3194C, IAB 7/5/17, effective 8/9/17]

**761—921.5(324A) Consideration in determining the approval of advance allocation application.** The department shall give consideration to the following items in determining the approval, disapproval or deferment of advance allocation applications:

**921.5(1)** The justification submitted with the application pursuant to subrule 921.3(3).

**921.5(2)** Previous experience of the department in dealing with the transit system making application including but not limited to the following:

- a. Timeliness of contract and application materials, as assessed by the department.
- b. Fiscal management capability of the transit system, as assessed by the department.

[ARC 3194C, IAB 7/5/17, effective 8/9/17]

**761—921.6** Rescinded, effective April 16, 1986.

**761—921.7(324A) Reports, and suspension and termination of allocations.**

**921.7(1)** Transit systems receiving advance allocations shall provide quarterly and end-of-the-year financial and statistical reports to the department in the manner and within the time limits described in the state transit assistance joint participation agreements. These reports shall be made through an online portal furnished to the transit systems by the department.

**921.7(2)** Failure to file quarterly and end-of-the-year financial and statistical reports by any transit system with the department in the manner and within the time limits described in the state transit assistance joint participation agreement shall be cause for suspension or termination of those provisions of the joint participation agreement, and therefore, suspension or termination of advance allocation payments made by the department. The department shall notify any transit system of such actions.

**921.7(3)** Payment of eligible joint participation agreement expenses to a transit system that has had advance allocation contract provisions suspended or terminated by the department shall be by the method of reimbursement payments as described in the state transit assistance joint participation agreements.

[ARC 3194C, IAB 7/5/17, effective 8/9/17]

**761—921.8(324A) Income derived from interest-bearing accounts and investments.**

**921.8(1)** Any transit system that receives advance allocation payments shall deposit these funds in a separately identified interest-bearing account until such time as they are expended on costs incurred by the transit system.

**921.8(2)** All income derived from interest-bearing accounts and investments shall be credited to the transit system and its transit accounts as a nonoperating or nontransportation revenue.

**761—921.9(324A) Joint participation agreement close and audits.**

**921.9(1)** Each transit system receiving advance allocations shall, as part of the end-of-the-year financial and statistical report, calculate the total joint participation agreement amount eligible for payment by the department within the limits stated in the joint participation agreement. This eligible joint participation agreement amount shall be compared to the total amount of the advance allocations for that joint participation agreement. If the advance allocations' total is greater than the eligible joint participation agreement amount, the transit system must repay the department the difference. After verification of these calculations, the department shall issue to the public transit system an invoice for the amount of the required repayment. Failure to make this repayment shall be grounds for:

- a. Termination of other transit assistance joint participation agreements with that transit system,
- b. Suspension or termination of further advance allocations made on future joint participation agreements,
- c. Reduction of department participation in existing or future joint participation agreements, or
- d. Reducing future joint participation agreement reimbursement requests of the transit system by an amount not to exceed the unpaid debt owed the department and crediting the outstanding debt of the project being closed out.

**921.9(2)** The department may institute any such action(s) as stated in subrule 921.9(1) above and shall notify any transit system of such action taken against the transit system.

**921.9(3)** After the repayment and end-of-the-year financial and statistical reports are submitted, or after the department has instituted any action(s) for failure to do so, the department shall audit the transit system's books, accounts, records and other material and information necessary to determine joint participation agreement compliance. The advance allocations paid to the transit system shall be taken into consideration and made part of the amount to be audited.

[ARC 3194C, IAB 7/5/17, effective 8/9/17]

These rules are intended to implement Iowa Code chapter 324A.

[Filed emergency 10/26/79—published 11/14/79, effective 10/26/79]

[Filed 2/20/86, Notice 1/1/86—published 3/12/86, effective 4/16/86]

[Filed 5/11/87, Notice 3/11/87—published 6/3/87, effective 7/8/87]

[Filed 1/15/92, Notice 12/11/91—published 2/5/92, effective 3/11/92]

[Filed emergency 7/1/92—published 7/22/92, effective 7/27/92]

[Editorial change: IAC Supplement 2/23/11]

[Filed ARC 3194C (Notice ARC 3034C, IAB 4/26/17), IAB 7/5/17, effective 8/9/17]

[Editorial change: IAC Supplement 2/24/21]

CHAPTER 922  
FEDERAL TRANSIT ASSISTANCE  
[Prior to 6/3/87, Transportation Department[820]—(09,B)Ch 3]

**761—922.1(324A) Projects for nonurbanized areas and private nonprofit transportation providers.**

**922.1(1) General information.**

*a.* Section 5310 of Title 49 United States Code established the enhanced mobility of seniors and individuals with disabilities program, a program of federal financial assistance for support of capital acquisitions for private nonprofit providers of specialized transportation services for seniors and persons with disabilities.

*b.* Section 5311 of Title 49 United States Code established the formula grants for rural areas program, a program of federal financial assistance for support of public transportation in rural areas with populations of less than 50,000, as defined by the U.S. Census Bureau.

*c.* Section 5339 of Title 49 United States Code established the bus and bus facilities program, a program of federal financial assistance for support of capital acquisitions for public transportation providers.

*d.* As required by Title 49 United States Code, the department has been designated by the governor to administer these programs within Iowa, subject to review by the Federal Transit Administration (FTA).

**922.1(2) State management plan.**

*a.* Sections 5310, 5311 and 5339 of Title 49 United States Code federal transit assistance programs within Iowa shall be administered according to the “Iowa State Management Plan for Administration of Funding and Grants Under the Federal Transit Administration, Sections 5310, 5311, 5316, 5317 and 5339 Programs,” dated May 2020, which has been prepared by the department and approved by the Federal Transit Administration in conformance with FTA Circulars 5100.1, 9040.1G and 9070.1G.

*b.* Copies of the state management plan are available from the Modal Transportation Bureau, Iowa Department of Transportation, 800 Lincoln Way, Ames, Iowa 50010; telephone (515)233-7870; or the department’s website at [www.iowadot.gov](http://www.iowadot.gov).

This rule is intended to implement Iowa Code chapter 324A.

[Editorial change: IAC Supplement 2/23/11; **ARC 3692C**, IAB 3/14/18, effective 4/18/18; **ARC 6707C**, IAB 11/30/22, effective 1/4/23]

[Filed 2/20/86, Notice 1/1/86—published 3/12/86, effective 4/16/86]

[Filed 5/11/87, Notice 3/11/87—published 6/3/87, effective 7/8/87]

[Filed 1/15/92, Notice 12/11/91—published 2/5/92, effective 3/11/92]

[Filed emergency 7/1/92—published 7/22/92, effective 7/27/92]

[Filed 1/27/94, Notice 12/22/93—published 2/16/94, effective 3/23/94]

[Editorial change: IAC Supplement 2/23/11]

[Filed ARC 3692C (Notice ARC 3536C, IAB 1/3/18), IAB 3/14/18, effective 4/18/18]

[Filed ARC 6707C (Notice ARC 6573C, IAB 10/5/22), IAB 11/30/22, effective 1/4/23]



CHAPTER 923  
CAPITAL MATCH REVOLVING LOAN FUND

[Prior to 6/3/87, Transportation Department[820]—(09.B)Ch 4]

**761—923.1(71GA,ch265) General information.**

**923.1(1)** *Scope of chapter.* The general assembly appropriated money from the petroleum overcharge fund to the department to be used as a revolving loan fund for transit capital purchases by public transit systems. The revolving loan fund will enable public transit systems to obtain the matching funds required to qualify for capital purchases under state or federally funded projects. The fund will provide multiyear interest-free loans to public transit systems to allow faster capital acquisitions. Loan recipients shall be required to demonstrate ability to repay the loan from budgeted funds or revenues.

**923.1(2)** *Information.* Requests for information about and for assistance with the preparation and submission of loan requests should be directed to the Public Transit Bureau, Iowa Department of Transportation, 800 Lincoln Way, Ames, Iowa 50010; telephone (515)233-7870. Information is also available on the department's website at [www.iowadot.gov](http://www.iowadot.gov).

[Editorial change: IAC Supplement 2/23/11; **ARC 3693C**, IAB 3/14/18, effective 4/18/18; **ARC 5498C**, IAB 3/10/21, effective 4/14/21]

**761—923.2(71GA,ch265) Definitions.**

*"Department"* means the Iowa department of transportation.

*"Project"* means a concerted set of actions that will develop, maintain or improve one or more elements of the public transit system's service.

*"Public transit system"* means the same as defined in Iowa Code section 324A.1.

[**ARC 3693C**, IAB 3/14/18, effective 4/18/18]

**761—923.3(71GA,ch265) System eligibility.** A public transit system is eligible to request a capital assistance loan from the revolving loan fund provided that the public transit system complies with all of the following criteria:

**923.3(1)** The transit system abides by all applicable state and federal laws and regulations.

**923.3(2)** The transit system maintains primary documentation for all revenues and expenses for a period of at least three years following contract closeout.

**923.3(3)** The transit system maintains the system's policies, routes, schedules, fare structure, and budget in a manner that encourages public review, responsiveness to user concerns, energy conservation, and fiscal solvency.

[**ARC 3693C**, IAB 3/14/18, effective 4/18/18; **ARC 5498C**, IAB 3/10/21, effective 4/14/21]

**761—923.4(71GA,ch265) Project eligibility.**

**923.4(1)** A project is eligible if it meets all of the following criteria:

a. The project is a transit-related project for a capital purchase, e.g., new or replacement vehicles, facilities, or both.

b. The project meets an identifiable transit need that has been included in the public transit system's adopted transportation improvement program.

c. The local funding needed for the project justifiably exceeds the public transit system's annual capital match funding capability.

**923.4(2)** A project to purchase vans for a vanpool, as defined in Iowa Code section 325A.12, may be submitted by an individual or a group through the appropriate public transit system. A vanpool project is eligible for an interest-free loan from the revolving loan fund only after funds for all other projects have been allocated.

[**ARC 3693C**, IAB 3/14/18, effective 4/18/18; **ARC 5498C**, IAB 3/10/21, effective 4/14/21]

**761—923.5(71GA,ch265) Procedure.**

**923.5(1)** *Funding request.* The public transit system shall submit a funding application for the proposed project to either the department or to the Federal Transit Administration, as required by the type of funding requested.

**923.5(2)** *Loan request.* The public transit system shall normally submit a request for a revolving fund loan to the department when the annual grant application is made, but may submit a request at any time if a specific need arises. The request shall include, but not be limited to, the following topics and documents:

a. A description and cost estimate of the proposed project.

b. An explanation of the benefits, including projected energy conservation benefits, to be gained from the project.

c. An explanation and justification of need for the loan.

d. A proposed schedule of when funds will be needed for the project.

e. A proposed loan repayment plan with schedule and source of funds.

**923.5(3) Criteria for selection.** The department shall review each loan request and shall evaluate the projects for funding. Based on the following criteria (in no particular order), preference shall be given to projects that:

a. Foster coordination among transit services, such as a ground transportation center, a joint maintenance facility, or cooperative vehicle usage.

b. Enhance local or regional economic development, such as a transit mall, passenger shelter facilities, or vehicles for extension of services.

c. Increase federal funding to the state, such as accelerating purchase of replacement vehicles.

d. Extend services to the transportation disadvantaged.

e. Promote energy conservation, such as fuel efficiency.

f. Require the loan as only a portion of the local matching funds required.

**923.5(4) Approval.** Based on available funds, the department shall approve loans for projects meeting the criteria in rule 761—923.4(71GA,ch265).

**923.5(5) Agreement.** Upon approval, the department shall prepare a loan contract and send it to the public transit system for execution.

**923.5(6) Default.** If a public transit system fails to make a loan payment as agreed in the contract, the department may, at its option, deduct the amount of any past due loan payment from state transit assistance payments allocated to that transit system.

[ARC 3693C, IAB 3/14/18, effective 4/18/18]

These rules are intended to implement 1985 Iowa Acts, chapter 265.

[Filed emergency 4/2/86—published 4/23/86, effective 4/4/86]

[Filed 6/10/86, Notice 4/23/86—published 7/2/86, effective 8/6/86]

[Filed emergency 10/9/86—published 11/5/86, effective 10/9/86]

[Filed 12/18/86, Notice 11/5/86—published 1/14/87, effective 2/18/87]

[Filed 5/11/87, Notice 3/11/87—published 6/3/87, effective 7/8/87]

[Filed 1/15/92, Notice 12/11/91—published 2/5/92, effective 3/11/92]

[Filed emergency 7/1/92—published 7/22/92, effective 7/27/92]

[Filed 9/8/94, Notice 7/20/94—published 9/28/94, effective 11/2/94]

[Editorial change: IAC Supplement 2/23/11]

[Filed ARC 3693C (Notice ARC 3535C, IAB 1/3/18), IAB 3/14/18, effective 4/18/18]

[Filed ARC 5498C (Notice ARC 5313C, IAB 12/16/20), IAB 3/10/21, effective 4/14/21]

CHAPTER 924  
PUBLIC TRANSIT INFRASTRUCTURE GRANT PROGRAM

**761—924.1(324A) Purpose.** The purpose of the public transit infrastructure grant program is to provide funding for improvement of the vertical infrastructure of Iowa's designated public transit systems.

**761—924.2(324A) Definitions.** The following definitions shall apply to this chapter:

“*Public transit system*” means the same as defined in Iowa Code section 324A.1.

“*Vertical infrastructure*” means the same as defined in Iowa Code section 8.57(5).

[ARC 3194C, IAB 7/5/17, effective 8/9/17; ARC 5498C, IAB 3/10/21, effective 4/14/21]

**761—924.3(324A) Information and forms.** Information, instructions, and application forms are available from the Public Transit Bureau, Iowa Department of Transportation, 800 Lincoln Way, Ames, Iowa 50010; telephone (515)233-7870; or the department's website at [www.iowadot.gov](http://www.iowadot.gov).

[ARC 3194C, IAB 7/5/17, effective 8/9/17; ARC 5498C, IAB 3/10/21, effective 4/14/21]

**761—924.4** Reserved.

**761—924.5(324A) Applicant eligibility.** Rescinded ARC 3194C, IAB 7/5/17, effective 8/9/17.

**761—924.6(324A) Project eligibility.** Projects may be considered for funding only if:

**924.6(1)** The project has been included in a locally approved transportation improvement program and in the statewide transportation improvement program.

**924.6(2)** Local match for the project is currently available.

**924.6(3)** The project is capable of being substantially completed within 18 months of project selection.

**761—924.7(324A) Eligible project activities.** Activities that are eligible for reimbursement include, but are not limited to, the following:

**924.7(1)** Construction, expansion, or renovation of facilities for administration of public transit operations, including any associated design, land acquisition, grading and foundation work.

**924.7(2)** Construction, expansion, or renovation of facilities for servicing, maintenance or storage of public transit vehicles, including any associated design, land acquisition, grading and foundation work.

**924.7(3)** Construction, expansion, or renovation of transit vehicle fueling facilities, including any associated design, land acquisition, grading and foundation work.

**924.7(4)** Construction, expansion, or renovation of passenger waiting facilities, including any associated design, land acquisition, grading and foundation work.

**924.7(5)** Relocating an existing administrative or maintenance facility, if necessary to correct violations of safety or design standards. Such project may include any associated design, land acquisition, grading and foundation work.

**761—924.8(324A) Ineligible project activities.** A transit facility may be incorporated into a larger project. Examples might include, but are not limited to, an intermodal facility, a headquarters for the umbrella organization sponsoring the transit program, or a public works facility. If this is the case, those costs attributable to the nontransit elements of the larger project shall not be eligible under this program.

**761—924.9** Reserved.

**761—924.10(324A) Funding.**

**924.10(1)** Program funds may reimburse up to 80 percent of transit-related project costs.

**924.10(2)** At least 20 percent of transit-related project costs must be provided from local sources by the sponsoring transit system in cash or value of real property.

**924.10(3)** Assistance from the public transit infrastructure grant program, when combined with federal or other state resources, may not exceed 80 percent of the project's transit-related costs.

**924.10(4)** No single public transit system may receive more than 40 percent of the funding available in one year.

[ARC 5498C, IAB 3/10/21, effective 4/14/21]

**761—924.11(324A) Project applications.**

**924.11(1)** Project applications shall be submitted to the department.

**924.11(2)** Each application shall contain:

*a.* General information, including the transit system name, contact person, mailing address, email address, telephone number, and fax number.

*b.* A project data sheet. The data sheet shall include the following:

(1) A brief description of the project and its purpose, project justification and anticipated benefits to the transit program.

(2) Cost information including total project cost and an itemized breakdown of project components (including transit vs. nontransit costs).

(3) The proposed implementation schedule.

(4) A statement of the applicant's ability to complete the project.

(5) A sketch of the project.

*c.* Documentation of project justification.

*d.* A resolution from the governing body of the sponsoring transit system endorsing the project and authorizing the necessary local funding match.

[ARC 3194C, IAB 7/5/17, effective 8/9/17]

**761—924.12 and 924.13** Reserved.

**761—924.14(324A) Project priorities.** The transportation commission shall consider the following in project selection:

**924.14(1)** Benefits of project to the transit program in terms of:

*a.* Enhancement of the life of the transit vehicle fleet.

*b.* Enhancement to transit services.

*c.* Increased ridership.

**924.14(2)** Readiness to proceed.

**924.14(3)** Feasibility of timely completion of the proposed project.

**924.14(4)** Ability of the project to leverage other funds.

**761—924.15(324A) Review and approval.** Department staff shall review project applications and shall submit recommendations to the transportation commission. The transportation commission is responsible for approving the projects to be funded.

[ARC 3194C, IAB 7/5/17, effective 8/9/17]

**761—924.16(324A) Project agreement, administration and ownership.**

**924.16(1) Agreement.** After a project has been approved, the department shall enter into an agreement with the transit system sponsoring the project.

**924.16(2) Payments.** Payments to the transit system sponsor for eligible project costs shall be made on a cost reimbursement basis.

**924.16(3) Ownership.** The transit system must retain ownership of the new, renovated or repaired structure or facility for its useful life. If the structure or facility is transferred to a subcontracted entity or is sold before the useful life has expired, the transit system must repay the prorated state interest to the department. Useful life thresholds can be found in the department's transit manager's handbook, available on the department's website at [www.iowadot.gov](http://www.iowadot.gov).

[ARC 3194C, IAB 7/5/17, effective 8/9/17; ARC 5498C, IAB 3/10/21, effective 4/14/21]

These rules are intended to implement Iowa Code sections 8.57, 324A.1 and 324A.6A.

[Filed 12/13/06, Notice 11/8/06—published 1/3/07, effective 2/7/07]

[Filed ARC 3194C (Notice ARC 3034C, IAB 4/26/17), IAB 7/5/17, effective 8/9/17]

[Filed ARC 5498C (Notice ARC 5313C, IAB 12/16/20), IAB 3/10/21, effective 4/14/21]